

# PARTS MANUAL

2023

3550 DEFOLIATOR

8 ROW 22

6 ROW 30

8 ROW 26

**Amity**  
TECHNOLOGY



2800 7<sup>th</sup> Avenue North  
Fargo, ND 58102

Phone: (701) 232-4199

Fax: (701) 234-1716

[www.amitytech.com](http://www.amitytech.com)



## TABLE OF CONTENTS

HITCH ASSEMBLY.....	1-4
DRIVE TRAIN.....	5-6
#2 FLAILS.....	7-10
#3 FLAILS.....	11-14
FLAIL TUBE ASSEMBLY.....	15-16
FLAIL TUBE MOUNTING.....	17-18
SIDE DOORS AND SHIELDS.....	19-20
SIDE PLASTIC ASSEMBLY.....	21-22
TOP DOOR ASSEMBLY.....	23-26
TOP DOOR HYDRAULICS.....	27-28
STANDARD REAR STRUTS-11.2 X 24 TIRES.....	29-30
OCSILLATING SPINDLE HOUSING.....	31-32
STANDARD REAR STRUTS-7.6 X 15 TIRES.....	33-34
STEERABLE REAR STRUTS-11.2 X 24 TIRES.....	35-38
STEERABLE REAR STRUTS-7.6 X 15 TIRES.....	39-42
SCALPER BAR ASSEMBLY.....	43-44
SCALPER BASKET.....	45-46
SCALPER HYDRAULICS.....	47-50
VALVE BLOCK AND MOUNT.....	51-54
SCRAPER MOUNTED ROW FINDER 12ROW.....	55-56
SCALPER MOUNTED ROW FINDER HYDRAULICS.....	57-58
FRAME MOUNTED ROWFINDER.....	59-60
ASSY-ROW FINDER MOUNT.....	61-62
FRAME MOUNTED ROWFINDER HYDRAULICS.....	63-64
HYDRAULIC ROW FINDER.....	65-68
REAR STRUT HYDRAULICS-11.2 X 24 TIRES (OPTIONAL).....	69-70
HITCH HYDRAULICS .....	71-72
FLOATING HITCH KIT .....	73-74
ACTIVE HEIGHT CONTROL COMPONENTS .....	75-92
LIGHT KIT .....	93-94
DECALS .....	95-98
GEARBOX-L TYPE #305301 .....	99-100
GEARBOX-L TYPE W/OVERRRRUN CLUTCH #305602 .....	101-102
GEARBOX-T TYPE #305603 .....	103-104
GEARBOX-T TYPE #305604 .....	105-106
PTO-STD 1.75 #305691 .....	107-108
PTO-CV 1.75 #305690 .....	109-110
SIDE DRIVELINE #305611 & #305612 .....	111-112
COUPLER-UNIVERSAL JOINT #68443 .....	113-114
HYDRAULIC LABEL ASSY .....	115-116
SNAP RING PLIERS .....	117

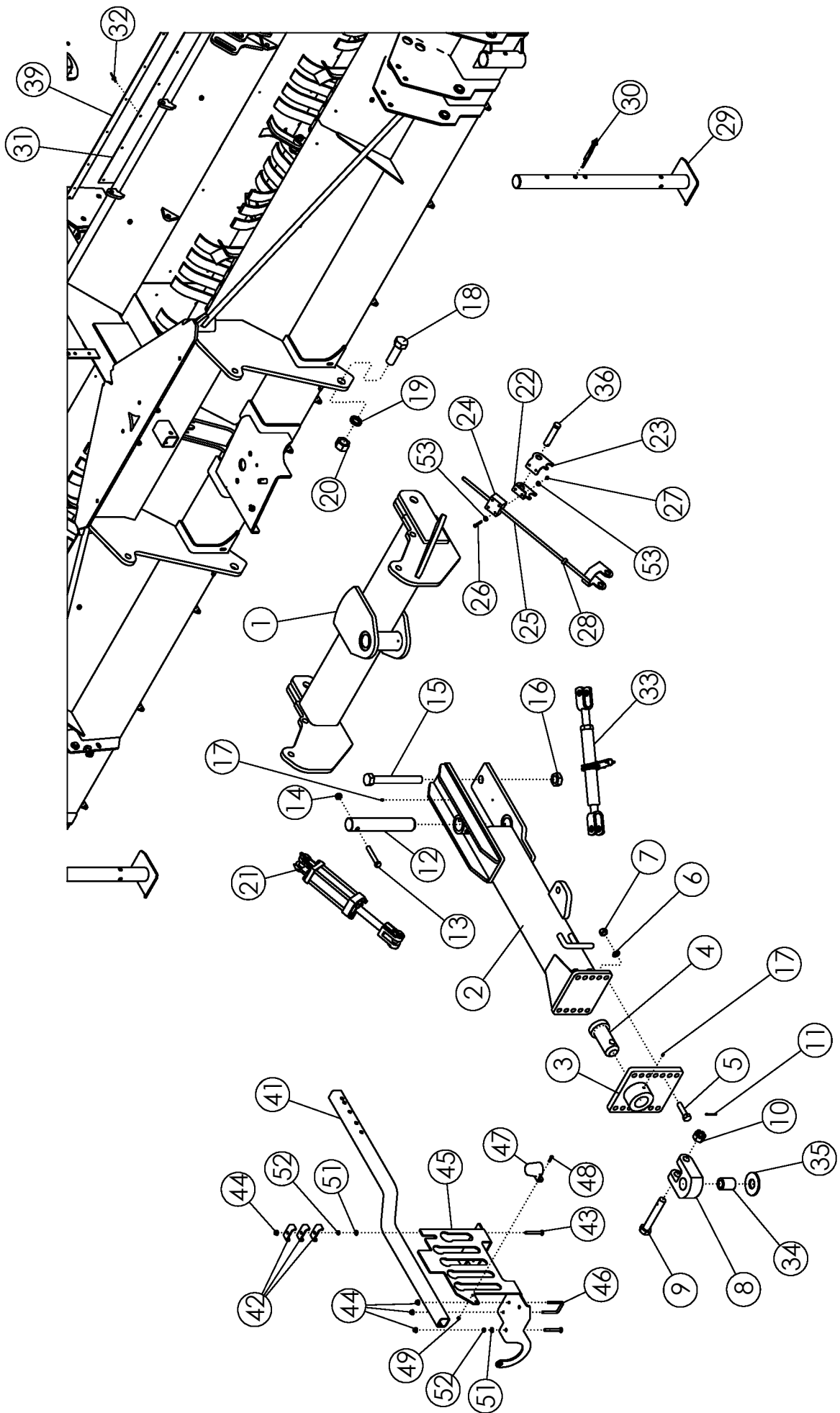

## HITCH ASSEMBLY

ITEM	PART NO.	DESCRIPTION	QTY
1	50341	WLDMT - STD HITCH PIVOT	1
2	68277	WLDMT - DRAWPOLE DEF	1
3	57930	WLDMT-HITCH PLATE	1
4	62101	WLDMT-PIN	1
5	1012059	BOLT-HEX: .75 X 3.00 NC GR5 ZP	6
6	1012061	WASHER-LOCK: .75 ZP	6
7	1011620	NUT-HEX: .75 NC GR2 ZP	6
8	64476	PLATE-PULL HITCH	1
9	62477	BOLT-HITCH DRILLED	1
10	62088	NUT-SLOTTED: 1.13 NC GR5 ZP	1
11	1013473	PIN-COTTER: .19 X 2.00 NP	1
12	50678	PIN	1
13	1015117	BOLT-HEX: .63 X 4.00 NC GR8 ZP	1
14	1016595	NUT-TOPLOCK: .63 NC GR5 ZP	1
15	1030756	BOLT-HEX: 1.25 X 10.50 NC GR5 ZP	1
16	1030759	NUT-TOPLOCK: 1.25 NC ZP	1
17	1011748	ZERK - GREASE	4
18	1030757	BOLT-HEX: 1.38 X 4.25 NC GR5 ZP	2
19	1030760	WASHER-LOCK: 1.38 ZP	2
20	1030758	NUT-HEX: 1.38 NC ZP	2
21	58891	CYLINDER-HYDRAULIC 4 X 8" 3000	2
	301315	SEAL KT-CYL 4 X 8, 4 X 10 3000PSI UNIVERSAL	
22	63995	TOP_BRACKET - RH	1
23	63996	TOP_BRACKET - LH	1
24	63383	POLY GUIDE BLOCK	1
25	63999	WLDMT - BOTTOM_BRACKET	1
26	1016211	BOLT-HEX: .25 X 2.00 NC GR5	4
27	1030946	NUT-TOPLOCK: .25 NC GR5 ZP	4
28	63359	COLLAR-SET: .563 ZP	1
29	52073	WLDMT-STAND	2
30	52408	SPRING PIN .50 X 3.50	2
31	305226	LINER-FRONT 12R (3750)	4
	306818	LINER-FRONT 8R 3550	2
	306183	LINER-FRONT 6R 3450	2
32	56886	RIVET-POP: .19 X .675 ZP	AR
33	52407	RATCHET JACK-PAINTED	1
34	64615	TUBE-SPACER 2.0 X 1.25	1
	64614	TUBE-SPACER 2.0 X 1.63	
35	58925	WASHER-HARDENED: 4.00 X 1.63	1
	68645	WASHER-FLAT: SPCL 2.125 X 4.50 X .184	
36	63406	PIN-CLEVIS: 1.00 X 4.00 ZP	1
37	52248	DECAL-CAUTION	1

CONTINUED

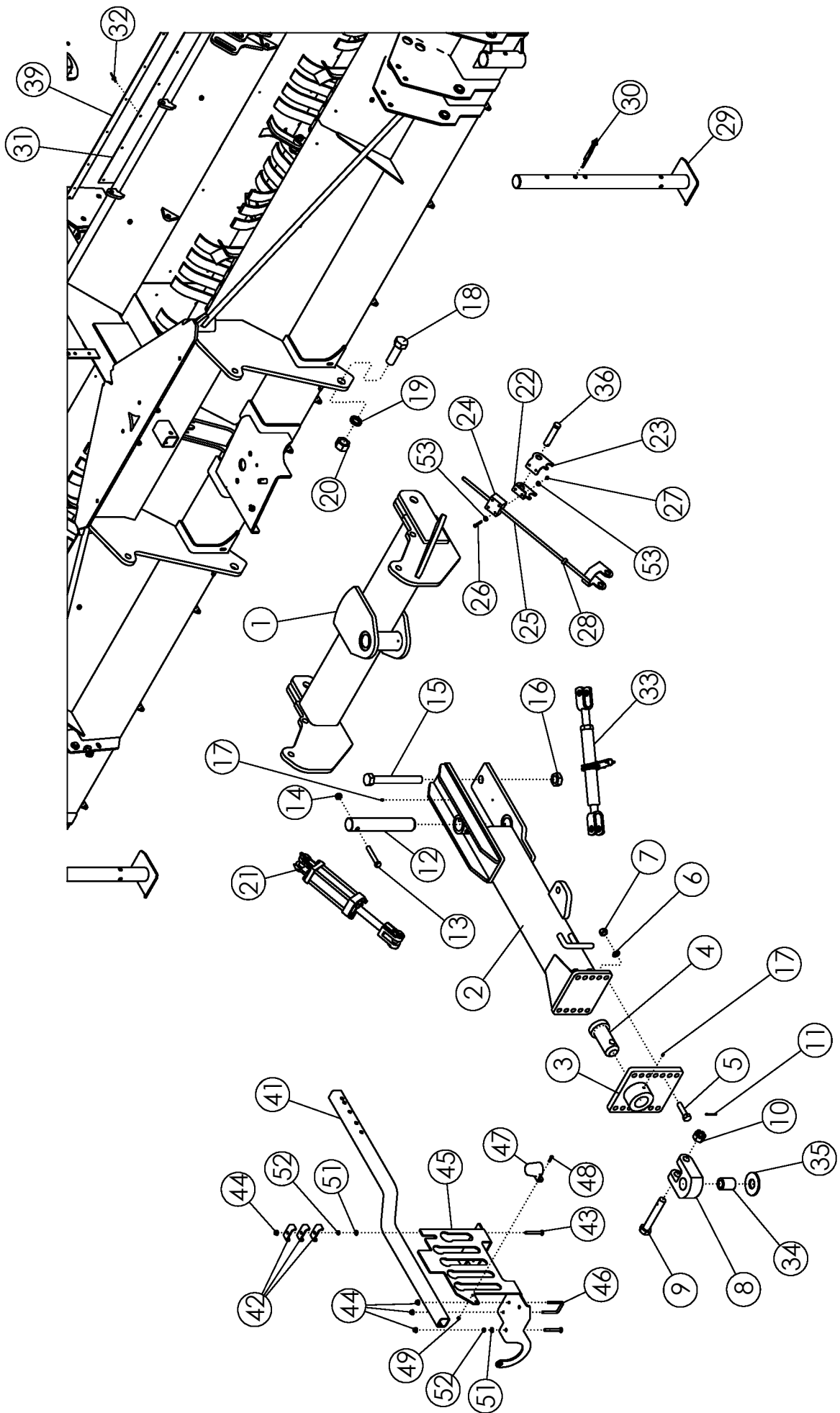

## HITCH ASSEMBLY (CONTINUED)

ITEM	PART NO.	DESCRIPTION	QTY
38	63405	DECAL-DEPTH GAUGE	1
39	305227	BAR-LINER RETAINER 12R 3750	4
	305492	BAR-LINER RETAINER 8R 3550	2
	306236	BAR-LINER RETAINER 8R SPLIT-FRM	2
	306184	BAR-LINER RETAINER 6R 3450	2
40	58090	SAFETY CHAIN 20200# (NOT SHOWN)	1
41	301135	TUBE-HYD HOSE HOLDER PC	1
42	50714	CLAMP 1/2" ZP	12
43	1030880	BOLT-CRG: .38 X 3.50 NC GR5 ZP	4
44	303731	NUT-FLANGE: TOPLOCK .38 NC YZP	8
45	303797	PLATE-HYD HOSE HOLDER W/ PTO CATCH	1
46	33162	U-BOLT: .375 X 3 X 2 X 3	2
47	223329	HOLDER-LIGHT PLUG	1
48	1013423	BOLT-HEX: .25 X 1.00 NC GR5 ZP	2
49	1030946	NUT-TOPLOCK: .25 NC GR5 ZP	2
50	1030882	BOLT-CRG: .38 X 2.50 NC GR5 ZP	4
51	1014608	WASHER-FLAT: SAE .38 ZP	4
52	1013519	NUT-JAM: .38 NC GR2 ZP	4

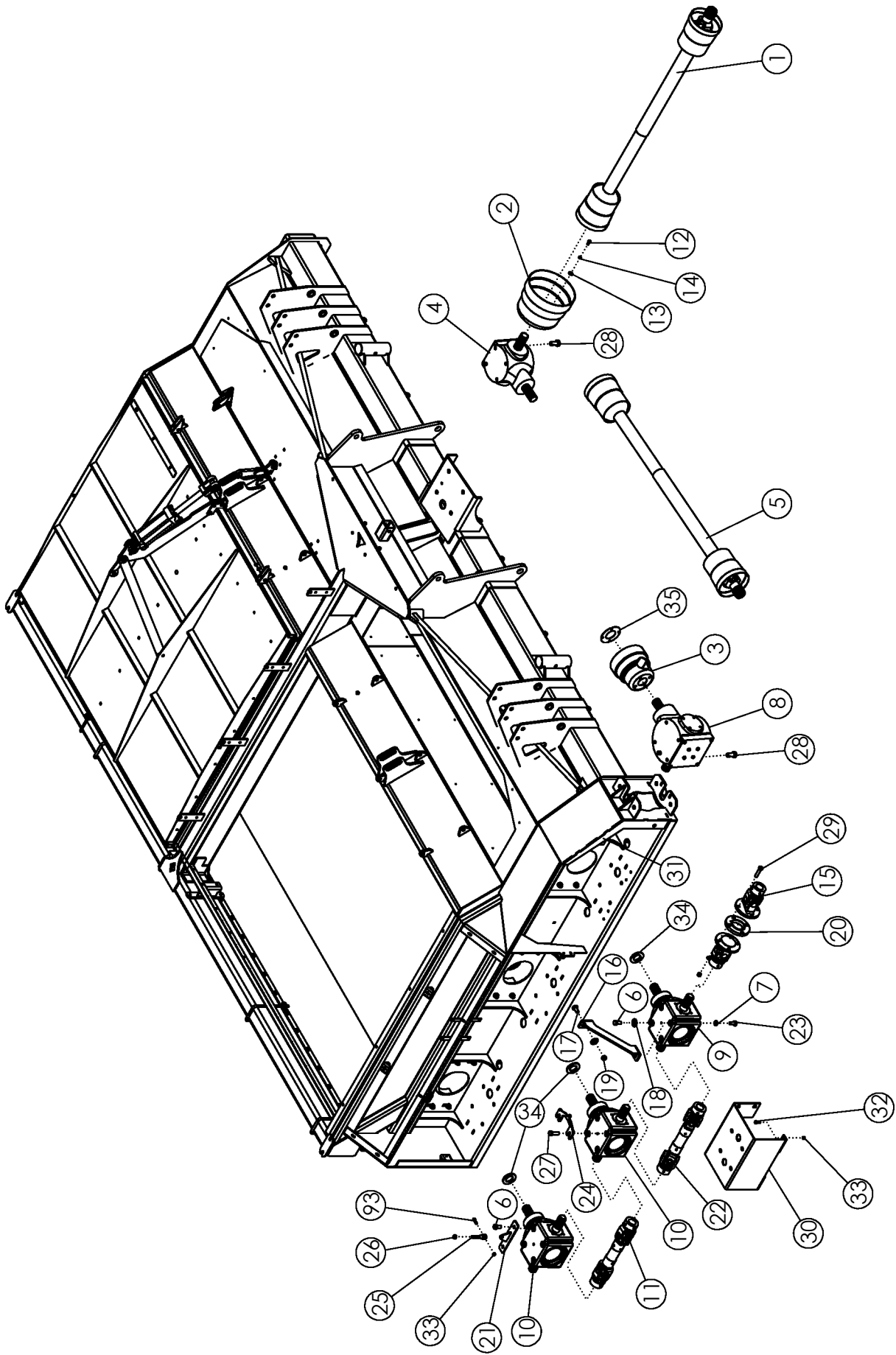



## DRIVE TRAIN

ITEM	PART NO.	DESCRIPTION	QTY
1	305690	CONSTANT VELOCITY PTO 1.75"	1
	305691	STANDARD PTO 1.75"	
2	52389	SHIELD CONE-LARGE	1
3	63972	SHIELD-CONE SMALL DRILLED	2
4	305601	GEARBOX-S2155 1.25:1 L	1
5	306401	CROSS SHAFT - 8R	1
6	68449	BOLT-HEX: M16 X 2.0 X L30	24
7	1011813	WASHER-LOCK: .63 ZP	22
8	305602	GEARBOX-S2155 1:1 L W/OVR RN CLU (BLACK)	1
9	305603	GEARBOX-S2125 1:1.35 T (BLACK)	1
10	305604	GEARBOX-S2125 1.93:1 T (BLACK)	2
11	305611	DRIVELINE-SIDE	1
12	68450	BOLT-HEX: M10 X 1.5 X L20	12
13	1011828	WASHER-FLAT: .38 ZP	12
14	1011586	WASHER-LOCK: .38 ZP	12
15	68443	COUPLER-U-JOINT	1
16	68970*	PLATE-GEARBOX SUPPORT	2
17	72063*	BOLT-CRG: .63 X 1.50 NC GR5 ZP	2
18	1013024*	WASHER-FLAT: .63 ZP	4
19	1016595*	NUT-TOPLOCK: .63 NC GR5 ZP	2
20	305154	PLATE-SPACER COUPLER 90 DEG	1
21	305617	WLDMT-GEARBOX ADJUSTMENT	1
22	305612	DRIVELINE-SIDE	1
23	305647	BOLT-HEX: M16 X 2.0 X L30 DIN 933-8.8	12
24	305626	PLATE-GEARBOX SPACER	8
25	305614	BOLT-CLEVIS .5"	1
26	1013429	NUT-CENTERLOCK: .50 NF GR5 ZP	1
27	306697	BOLT-FLG: M16 X 2.0 X L50 CL10.9 ZP	4
28	305646	BOLT-HEX: M20 X 2.5 X L45 CL8.8 ZP NDP	4
29	305192	BOLT-HEX: .56 X 3.00 NC GR5 ZP	4
30	306095	WLDMT-GEARBOX BRACE	1
31	306096	PLATE-GEARBOX BRACE BACKING	2
32	1011600	BOLT-HEX: .38 X 1.00 NC GR5 ZP	4
33	1016999	NUT-TOPLOCK: .38 NC GR5 ZP	4
34	306388	RUBBER-FLAIL TUBE SPACER	6
35	306103	PLATE-RETAINER PTO SHIELD	2

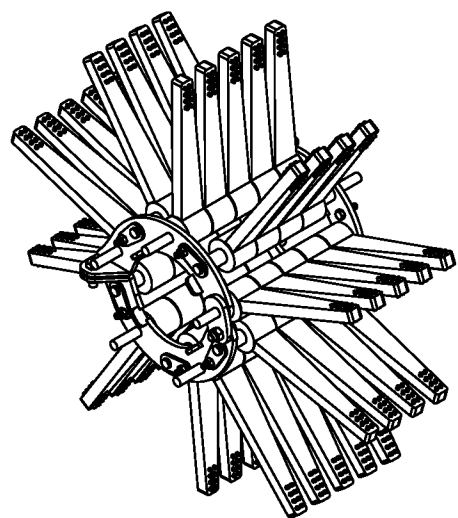
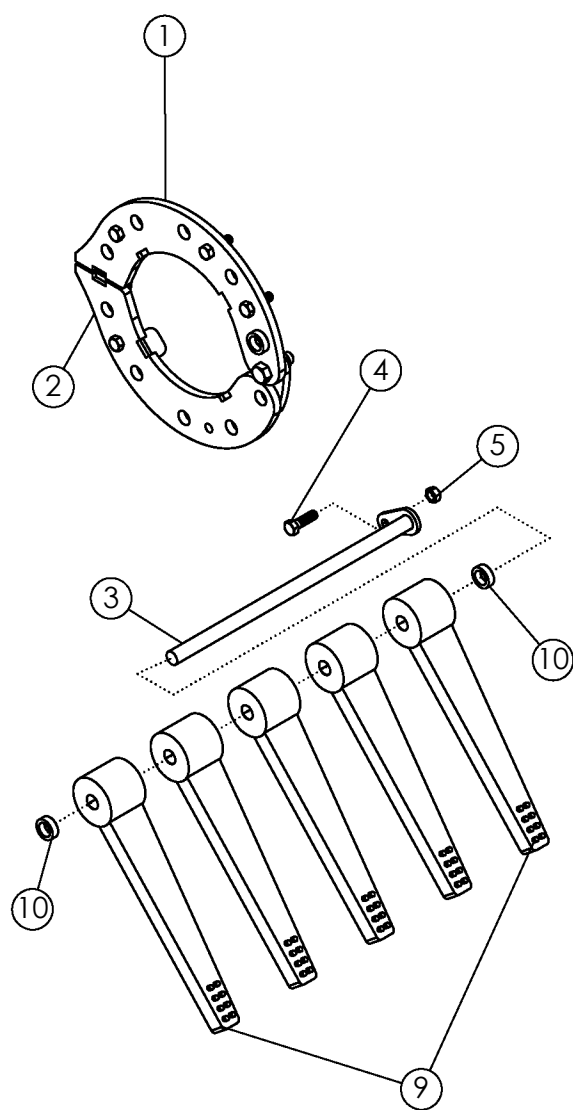
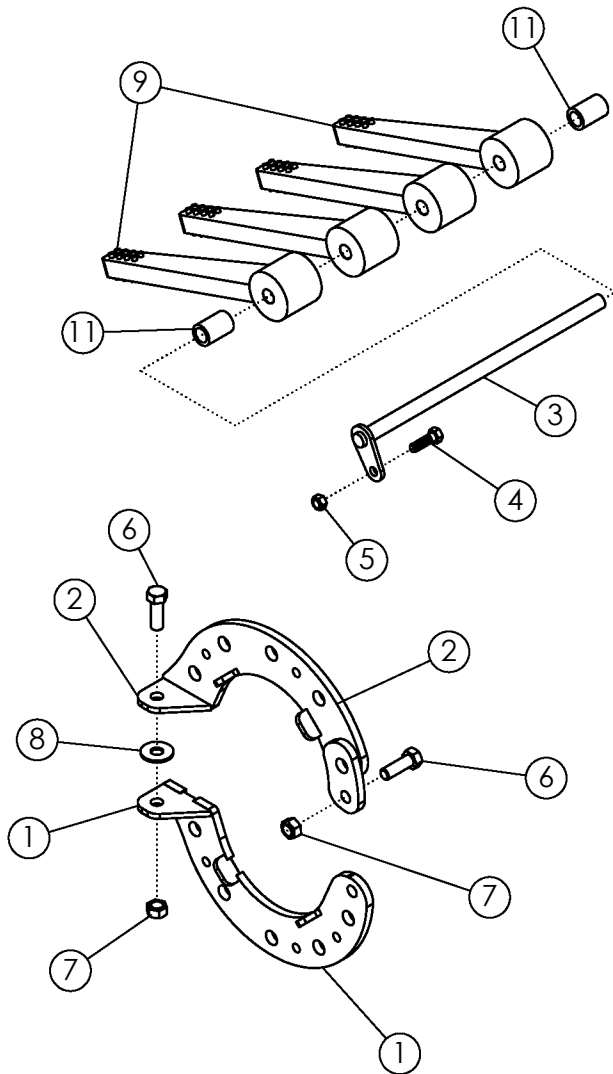

## **ASSY-FLAIL #2 10 ROD #305696**

<b>ITEM</b>	<b>PART NO.</b>	<b>DESCRIPTION</b>	<b>QTY</b>
1	305522	WLDMT-FLAIL RING 10 ROD	2
2	305523	WLDMT-FLAIL RING 10 ROD	2
3	305499	WLDMT-10 FLAIL ROD	10
4	1011601	BOLT-HEX: .38 X 1.25 NC GR5 ZP	10
5	1016999	NUT-TOPLOCK: .38 NC GR5 ZP	10
6	1011607	BOLT-HEX: .50 x 1.50 NC GR5 ZP	4
7	1027461	NUT-TOPLOCK: .50 NC GR5 ZP	4
8	1014443	WASHER-FLAT: .50 ZP	2
9	52354	FLAIL-RUBBER 1 X 12 (PREMIER)	45
10	51547	SPACER-SHORT	10
11	51548	SPACER-LONG	10

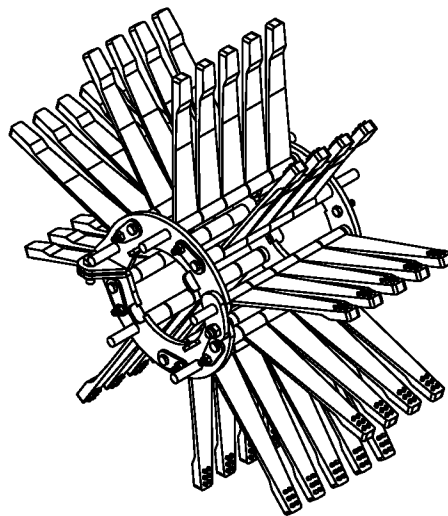
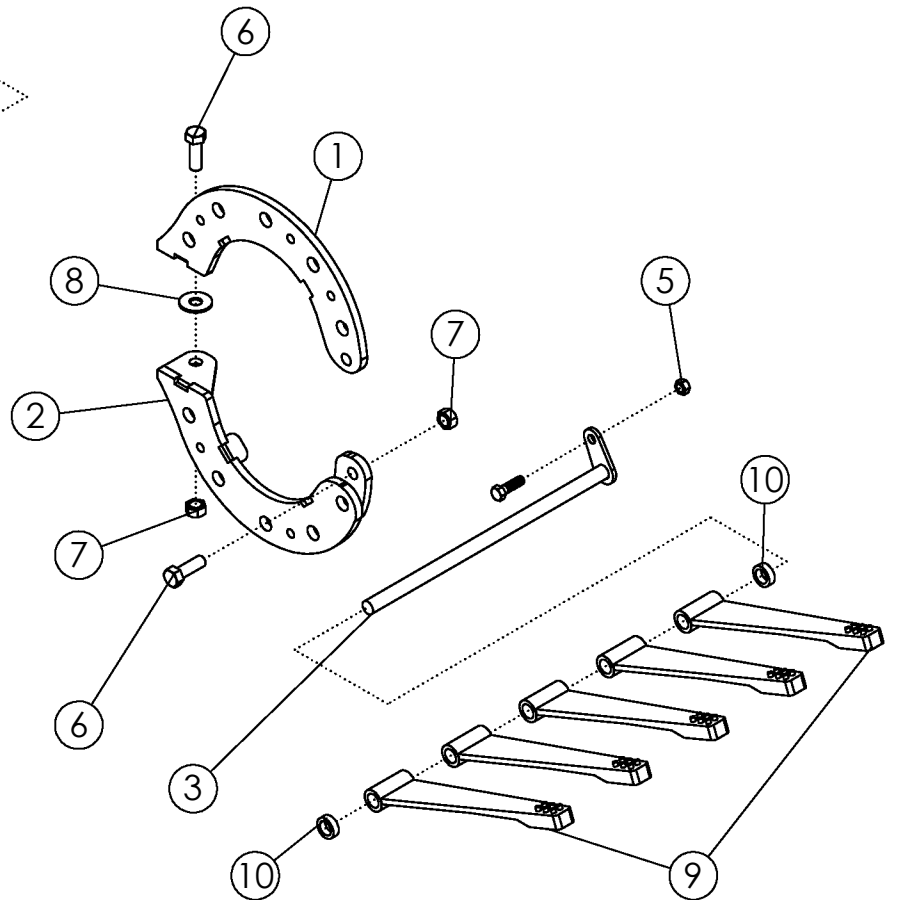
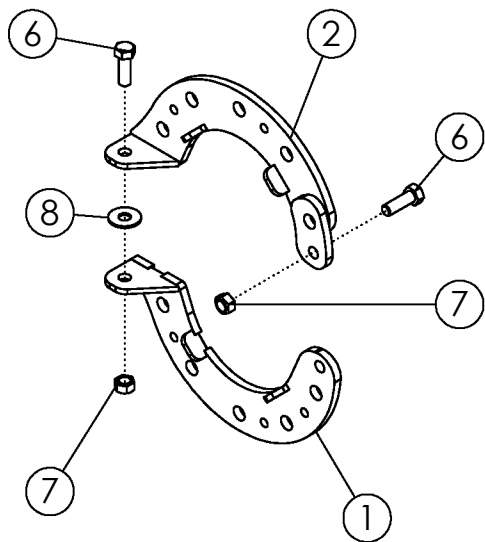
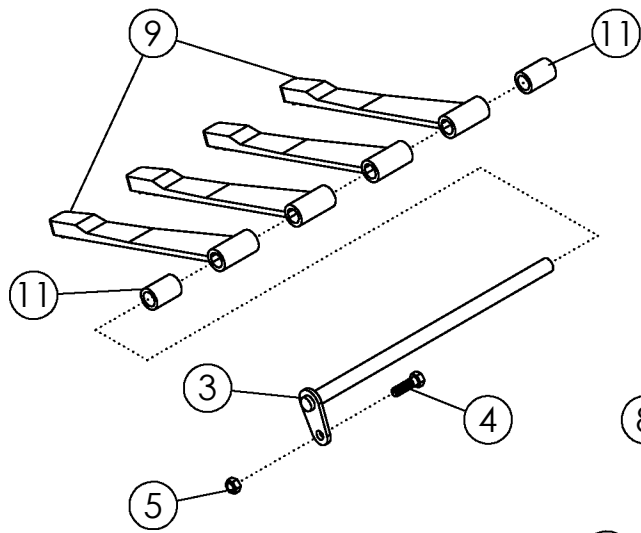

## ASSY FLAIL #2 ROD #305776

ITEM	PART NO.	DESCRIPTION	QTY
1	305522	WLDMT-FLAIL RING 10 ROD	2
2	305523	WLDMT-FLAIL RING 10 ROD	2
3	305499	WLDMT-10 FLAIL ROD	10
4	1011601	BOLT-HEX: .38 X 1.25 NC GR5 ZP	10
5	1016999	NUT-TOPLOCK: .38 NC GR5 ZP	10
6	1011607	BOLT-HEX: .50 x 1.50 NC GR5 ZP	4
7	1027461	NUT-TOPLOCK: .50 NC GR5 ZP	4
8	1014443	WASHER-FLAT: .50 ZP	2
9	52356	FLAIL-STUDDDED 1 X 12	45
10	51547	SPACER-SHORT	10
11	51548	SPACER-LONG	10

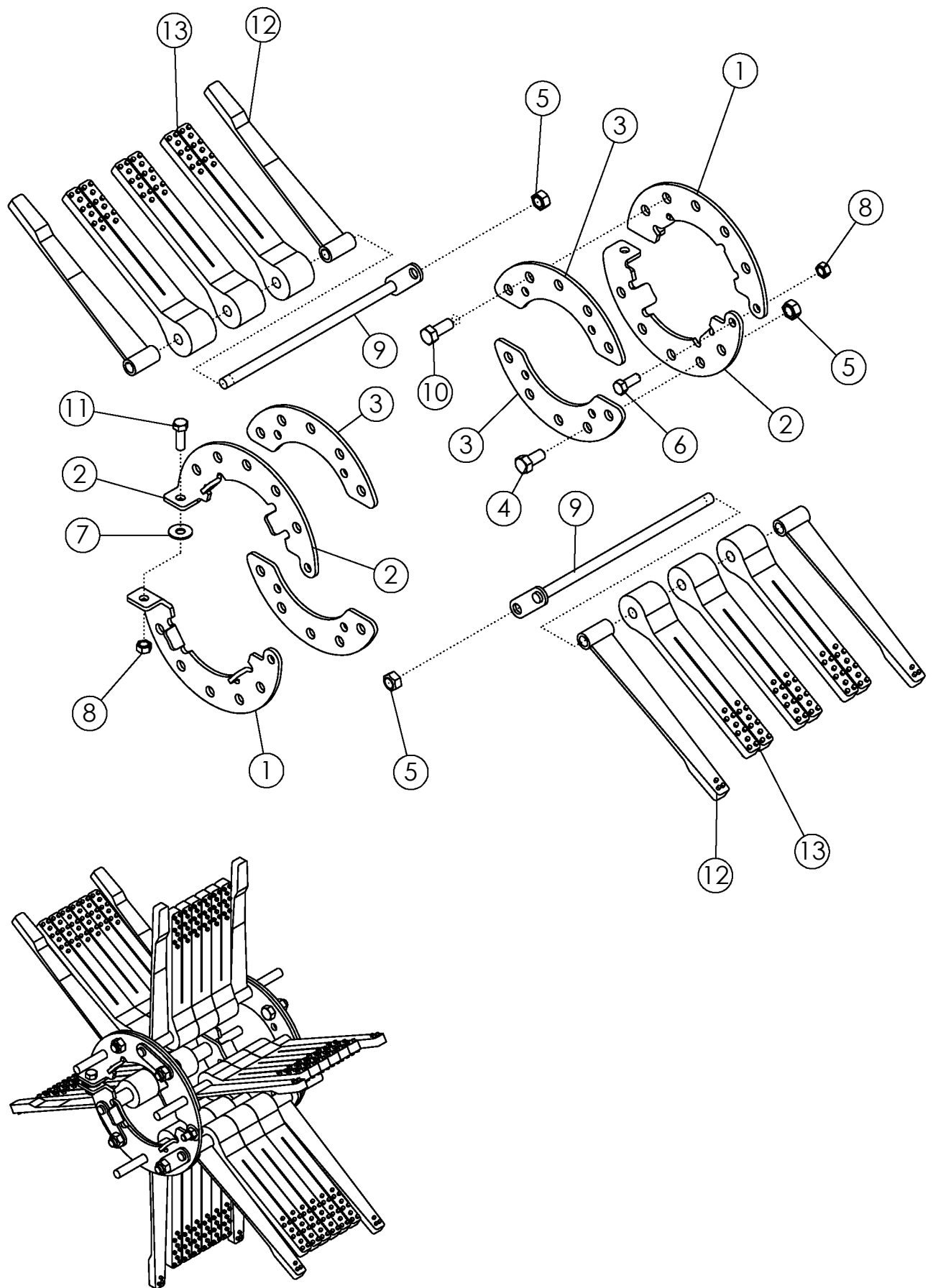

## FLAILS ON #3 DRUM

ITEM	PART NO.	DESCRIPTION	QTY
1	52062	FLAIL RING-LH	2
2	52061	FLAIL RING-RH	2
3	58084	PLATE-REINFORCEMENT ZP	4
4	1032509	BOLT-HEX: .63 X 1.25 NC GR5 ZP	2
5	1016595	NUT-TOPLOCK: .63 NC GR5 ZP	8
6	1011606	BOLT-HEX: .50 X 1.25 NC GR5 ZP	2
7	1014443	WASHER-FLAT: .50 ZP	2
8	1027461	NUT-TOPLOCK: .50 NC GR5 ZP	4
9	305557	FLAIL ROD	6
10	1014349	BOLT-HEX: .63 X 1.50 NC GR5 ZP	6
11	1011607	BOLT-HEX: .50 X 1.50 NC GR5 ZP	2
12	52355	FLAIL-SWEEP 1 X 13-1/4	12
13	58255	FLAIL-SPLIT TAPER 2 X 12	18
	52356	FLAIL-STUDDER 1 X 12	18

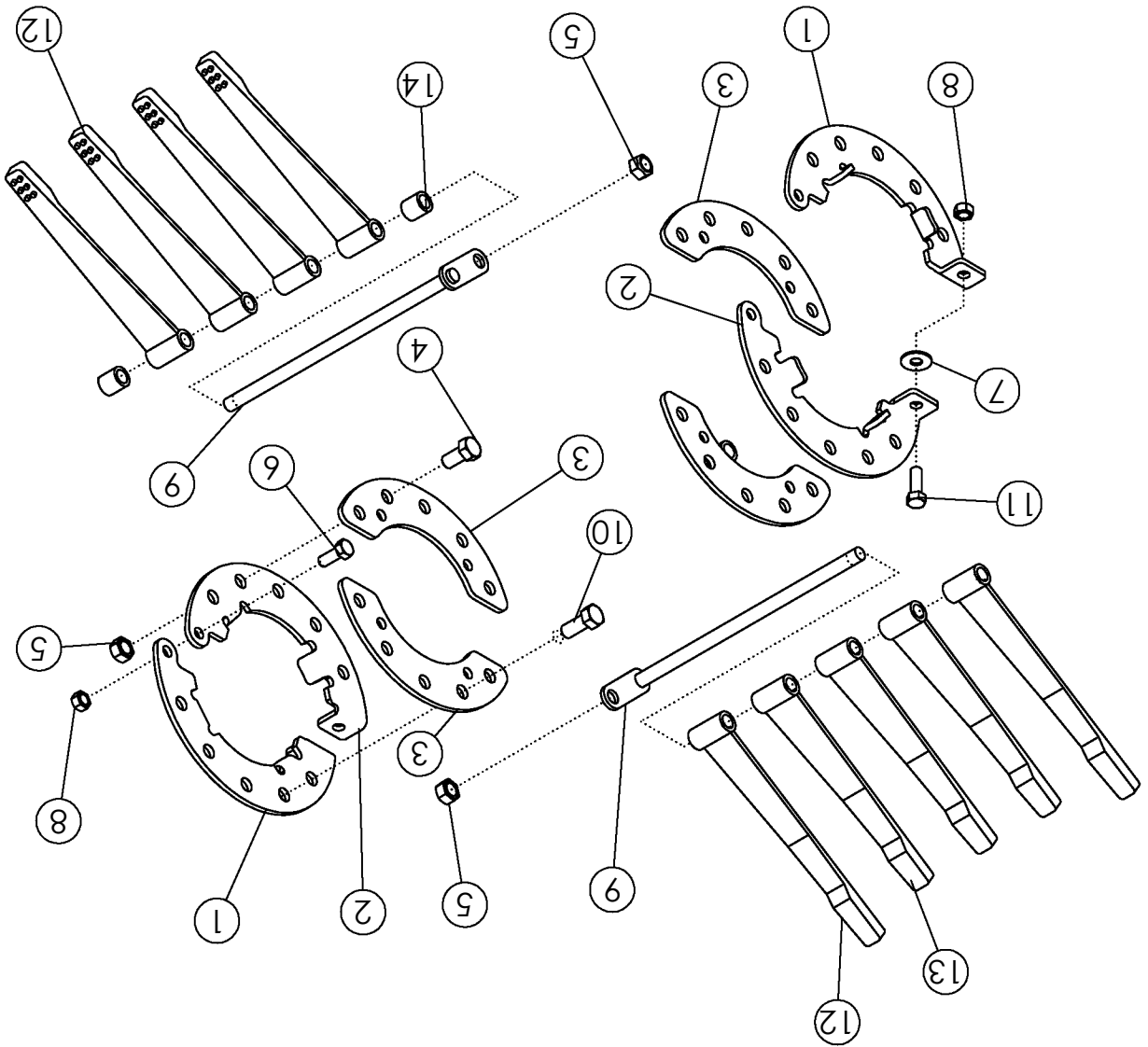
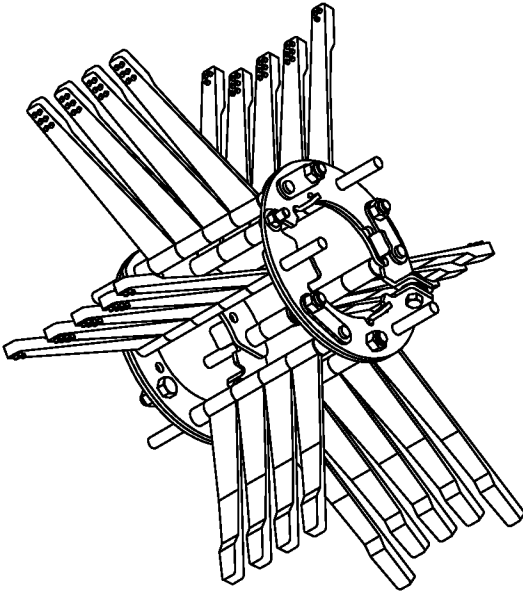



## FLAILS ON #3 DRUM

ITEM	PART NO.	DESCRIPTION	QTY
1	52062	FLAIL RING-LH	2
2	52061	FLAIL RING-RH	2
3	58084	PLATE-REINFORCEMENT ZP	4
4	1032509	BOLT-HEX: .63 X 1.25 NC GR5 ZP	2
5	1016595	NUT-TOPLOCK: .63 NC GR5 ZP	8
6	1011606	BOLT-HEX: .50 X 1.25 NC GR5 ZP	2
7	1014443	WASHER-FLAT: .50 ZP	2
8	1027461	NUT-TOPLOCK: .50 NC GR5 ZP	4
9	305557	FLAIL ROD	6
10	1014349	BOLT-HEX: .63 X 1.50 NC GR5 ZP	6
11	1011607	BOLT-HEX: .50 X 1.50 NC GR5 ZP	2
12	52355	FLAIL-SWEEP 1 X 13-1/4	6
13	52354	FLAIL-RUBBER 1 X 12 (PREMIER)	21
14	51548	SPACER 1"	6

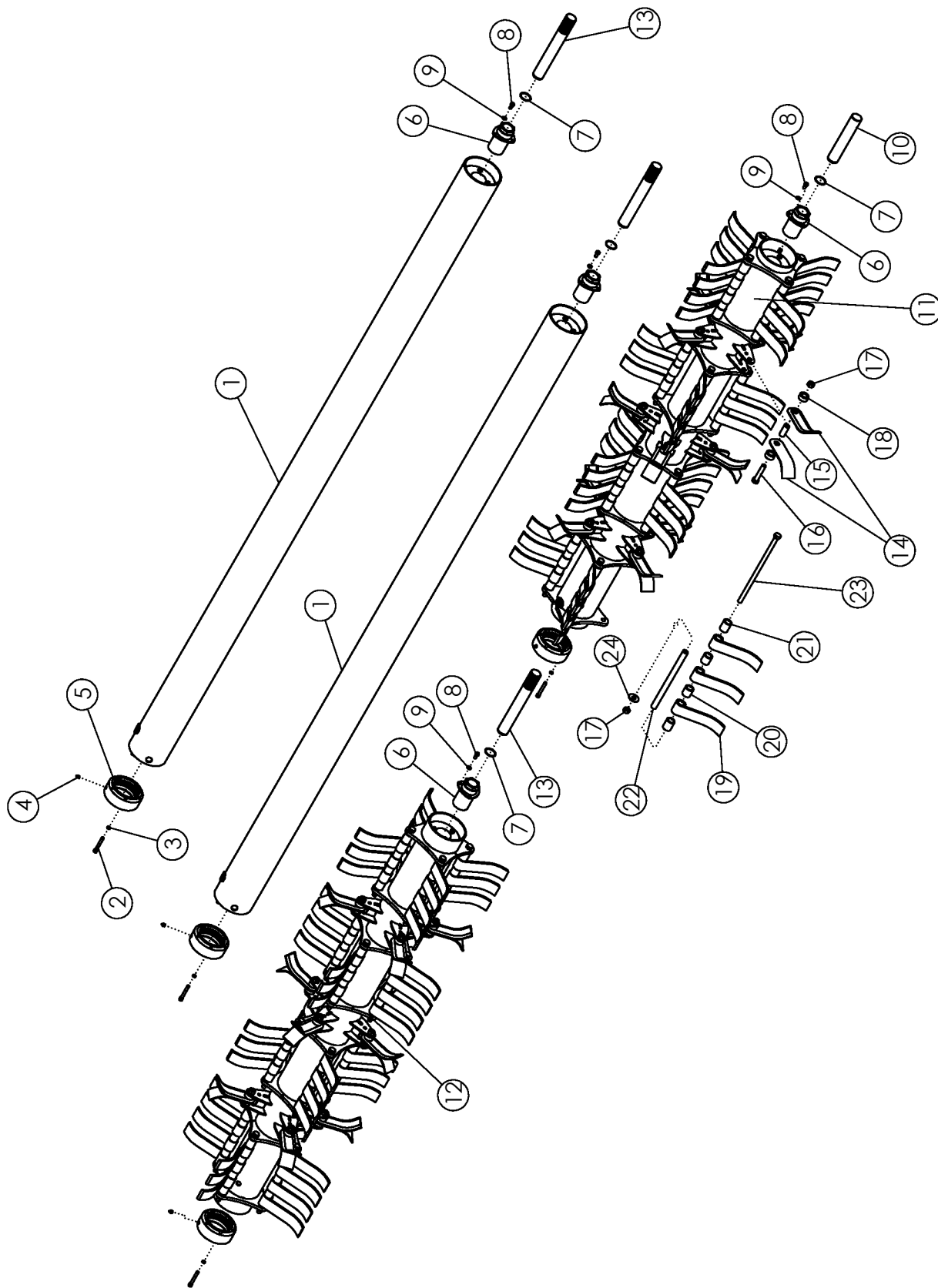

## FLAIL TUBE ASSEMBLY

ITEM	PART NO.	DESCRIPTION	QTY
1	68490*	FLAIL TUBE - 0822 TT (COMPLETE)	2
2	68417	SCREW: S-H-CAP .38 X 2.75 NC	24
3	68418	WASHER-LOCK: .38 HIGH COLLAR	24
4	1030766	ZERK-GREASE: .13 NPT	4
5	68412	DRIVE SLEEVE	4
6	64163	TRANTORQUE: 1.750" X 3.375"	4
7	64184	RING-RETAINING 1.750"	4
8	1011599	BOLT-HEX: .38 X .75 NC GR5 ZP	12
9	1011586	WASHER-LOCK: .38 ZP	12
10	68445	SHAFT-IDLER	1
11	307358	ASSY-DRUM CUP 7"-1.25" EYE W/FLAIL 5.31" LH 822	1
	307351	ASSY-DRUM CUP 7"-1.25" EYE W/FLAIL 5.31" LH 630	
12	307365	ASSY-DRUM CUP 7"-1.25" EYE W/FLAIL 5.31" RH 822	1
	307344	ASSY-DRUM CUP 7"-1.25" EYE W/FLAIL 5.31" RH 630	
13	68442	SHAFT-SPLINED COUPLING	3
14	307236	FLAIL-STEEL 5.31" LONG	32-48
15	68427	BUSHING-L KNIFE	16-24
16	65825	BOLT-HEX: .63 X 3.25 NC GR5 ZP	16-24
17	1016595	NUT-TOPLOCK: .63 NC GR5 ZP	40-56
18	68426	SPACER- L KNIFE	32-48
19	307387	FLAIL-CUP 7.0" 1.25" EYE	84-112
20	307390	SPACER 1.45" LARGE	60-80
21	307391	SPACER 1.70" LARGE	24-32
22	307388	BUSHING-FLAIL 12.688" 1.13" OD HT	24-32
23	306766	BOLT-HEX: .63 X 14.87 NC GR8 ZP	24-32
24	1013024	WASHER-FLAT: .63 ZP	24-32

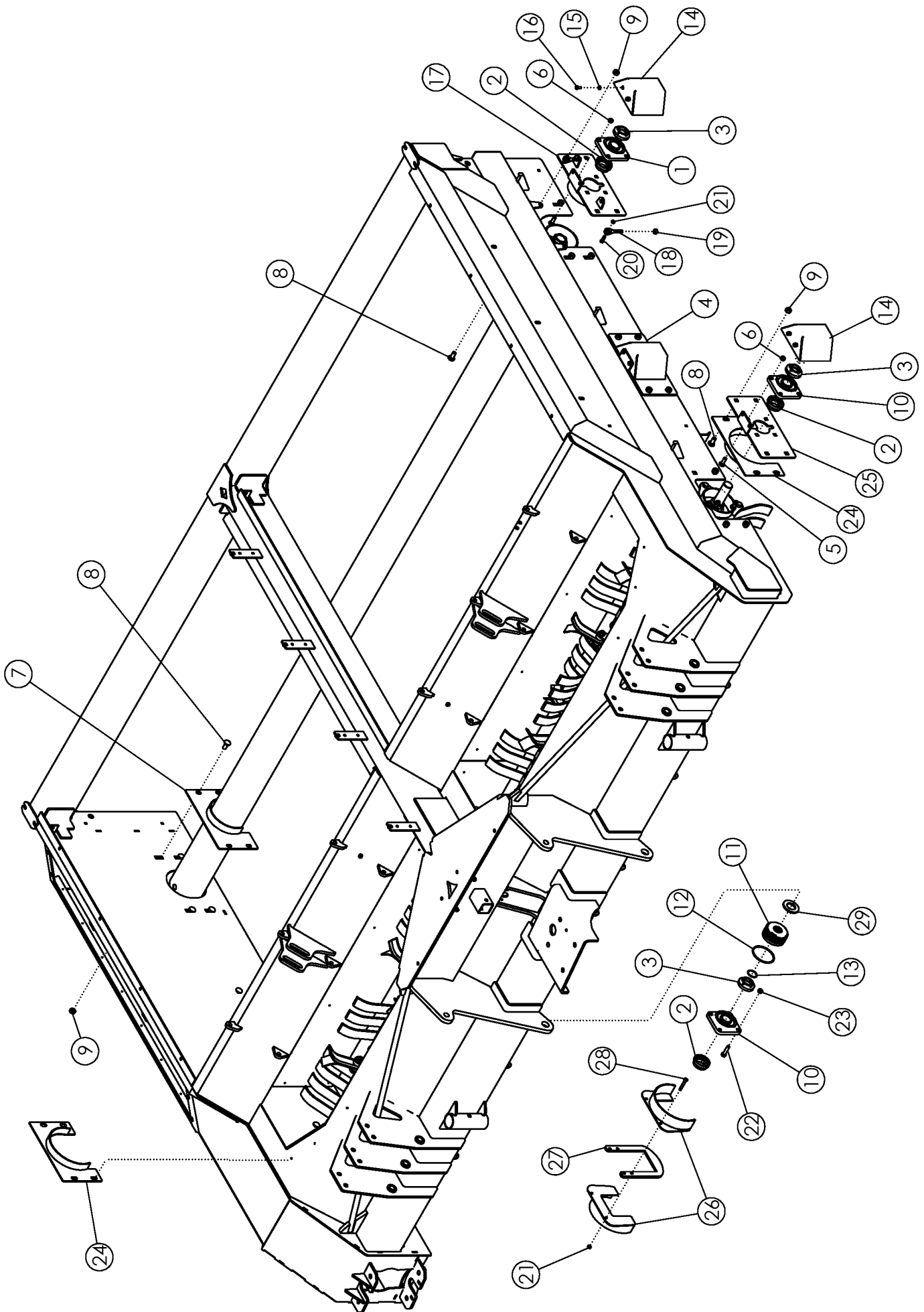

## FLAIL TUBE MOUNTING

ITEM	PART NO.	DESCRIPTION	QTY
1	52404	BEARING-FLANGE 1.75	2
2	52382	SEAL PROTECTOR 1.75	4
3	52383*	LOCK PROTECTOR 1.75	4
4	68244	WLDMT-BEARING PLATE	2
5	1011660	BOLT-CRG: .50 X 1.50 NC GR5 ZP	12
6	1027461	NUT-TOPLOCK: .50 NC GR5 ZP	12
7	51809	WLDMT-SHIELD ANTI WRAP NARROW	2
8	72063	BOLT-CRG: .63 X 1.50 NC GR5 ZP	24
9	1016595	NUT-TOPLOCK: .63 NC GR5 ZP	24
10	306999	ASSY-BEARING-FLANGE 1-3/4" N-SEAL (STEEL)	2
11	68413	COUPLER-DRIVE	4
12	68414	O-RING 70 BUNA	4
13	68415	SNAP RING	5
14	68462	WLDMT-IDLER SHIELD	3
15	1011586	WASHER-LOCK: .38	6
16	1011599	BOLT-HEX: .38 X .75 NC GR5 ZP	6
17	305624	WLDMT-BEARING PLATE ADJ	1
18	305614	BOLT-CLEVIS .50"	3
19	1011500	NUT-CENTERLOCK: .50 NC GR2 ZP	3
20	1011601	BOLT-HEX: .38 X 1.25 NC GR5 ZP	3
21	1016999	NUT-TOPLOCK: .38 NC GR5 ZP	5
22	62147	BOLT-HEX: .50 X 2.00 NC GR8 ZP	4
23	36233	NUT-TOPLOCK: .50 NC GR8 ZP	4
24	307290	WLDMT-8.5" ANTI WRAP NARROW	2
25	307296	PLATE-DRUM BEARING MOUNT RED	1
26	307293	WLDMT-8.5" ANTI WRAP WDE	2
27	307315	PLATE-DRUM FAILURE CATCH 2.0	1
28	1015174	BOLT-HEX: .38 X 2.50 NC GR5 ZP	2
29	306388	RUBBER-FLAIL TUBE SPACER	4

\* Replaces lock collar provided with bearing for the center

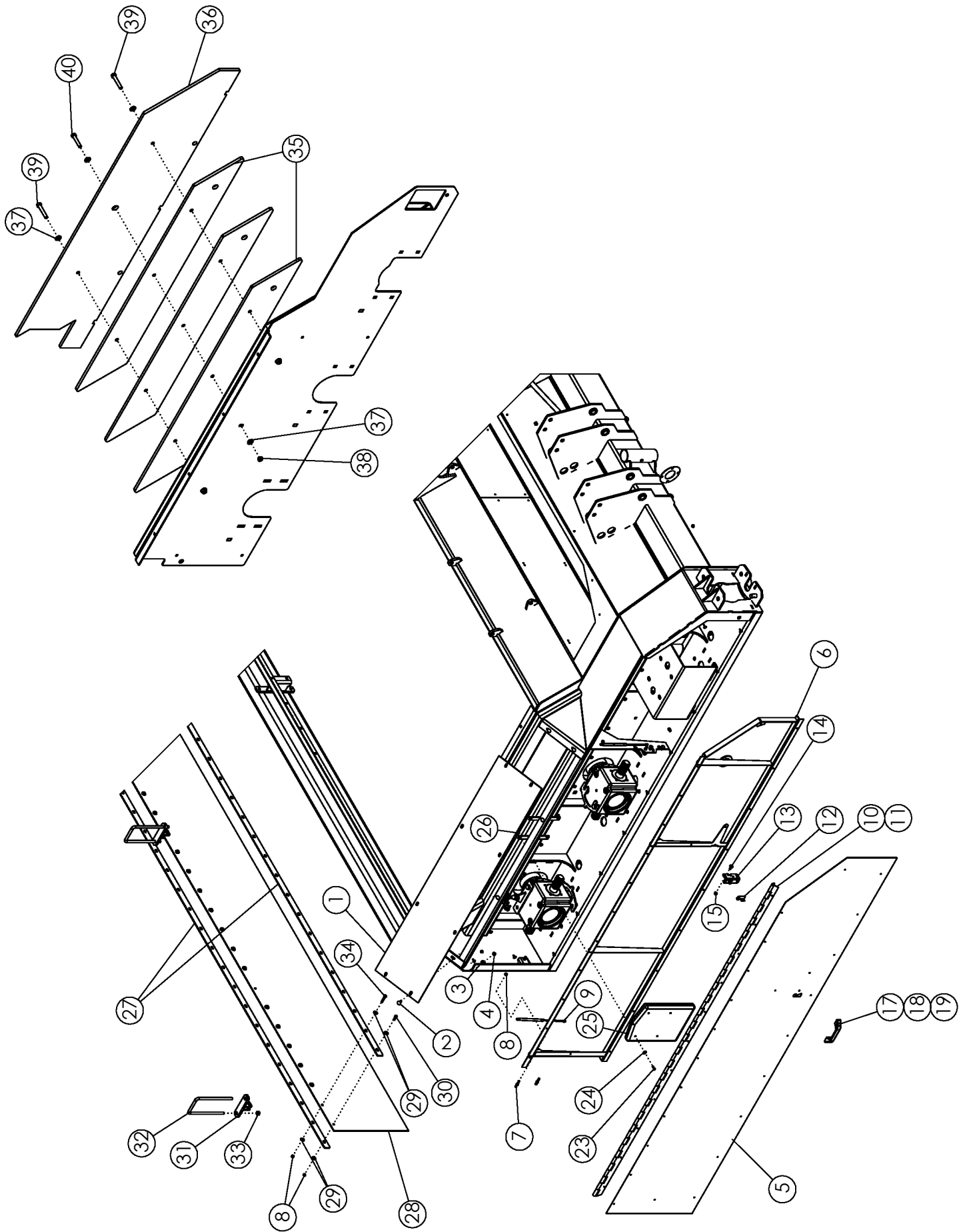

## SIDE DOOR AND SHIELDS

ITEM	PART NO.	DESCRIPTION	QTY
1	305233	SHEET-TOP SHIELD	1
2	59488	BOLT-CRG: .38 X 1.00 C R5 ZP	8
3	1011828	WASHER-FLAT: .38 ZP	8
4	1016999	NUT-TOPLOCK: .38 NC GR5 ZP	8
5	305234	SHEET-DIDE DOOR 12R	1
6	305235	WLDMT-DOOR FRAME 12R	1
7	69278	STUD-BALL 5/16-18 NC X .75	4
8	1030700	NUT-TOPLOCK: .31 NC GR5 ZP	50
9	305225	SPRING-GAS SHOCK 150LB 8" STROKE	2
10	305224	HINGE-HEAVY CONTINUOUS	1
11	1011974	RIVET-POP: .19 X .550 ZP	34
12	69284	LEVER-HRV LATCH ZP	1
13	69283	LATCH -ROTARY	1
14	65702	BOLT-CRG: .31 X 0.75 NC GR5 ZP	2
15	67077	NUT-FLANCE: SERR .31 NC ZP GR2	4
16	1029448	BOLT-HEX: .31 X 3.00 NC GR5 ZP	1
17	69285	HANDLE-MOLDED GRAB	1
18	67078	SCREW-P-H: 10-24 X .75 N CGR2 ZP	2
19	1026591	NUT-K-LOCK: 10-24 N CGR2 ZP	2
20	68324	PLATE-DEF MANUAL CASE	1
21	68602	BOLT-CRG: .25 X .75 NC GR5 ZP	4
22	1030946	NUT-TOPLOCK: .25 NC GR5 ZP	4
23	1011595	BOLT-HEX: .25 X .75 NC GR5 ZP	4
24	1020416	WASHER-FLAT: .25 ZP	4
25	64635	CASE-MANUAL STORAGE	1
26	1030946	NUT-TOPLOCK: .25 NC GR5 ZP	
27	63447	BAR-REAR FLAP 0822, 0630	4
28	52358	FLAP-REAR 0822, 0630	2
29	1011583	WASHER-FLAT: .31 ZP	52
30	1011598	BOLT-HEX: .31 X 1.00 NC GR5 ZP	26
31	63448	WLDMT-REAR FLAP MOUNT	4
32	63458	U-BOLT: .500 X 9.25 X 4 X 9.25	4
33	1027461	NUT-TOPLOCK: .50 NC GR5 ZP	8
34	1013424	BOLT-HEX: .31 X 1.75 NC GR5 ZP	4
35	305789	PLATE-WEIGHT DEF	3
	306235	PLATE-WEIGHT DEF SPLIT-FRAME	
36	305798	PLATE-WEIGHT OUTER DEF	1
37	1013004	WASHER-FLAT: SAE .63 ZP	6
38	1016595	NUT-TOPLOCK: .63 NC GR5 ZP	3
39	59093	BOLT-HEX: .63 x 3.75 NC GR5 ZP	2
40	65825	BOLT-HEX: .63 X 3.25 NC GR5 ZP	1

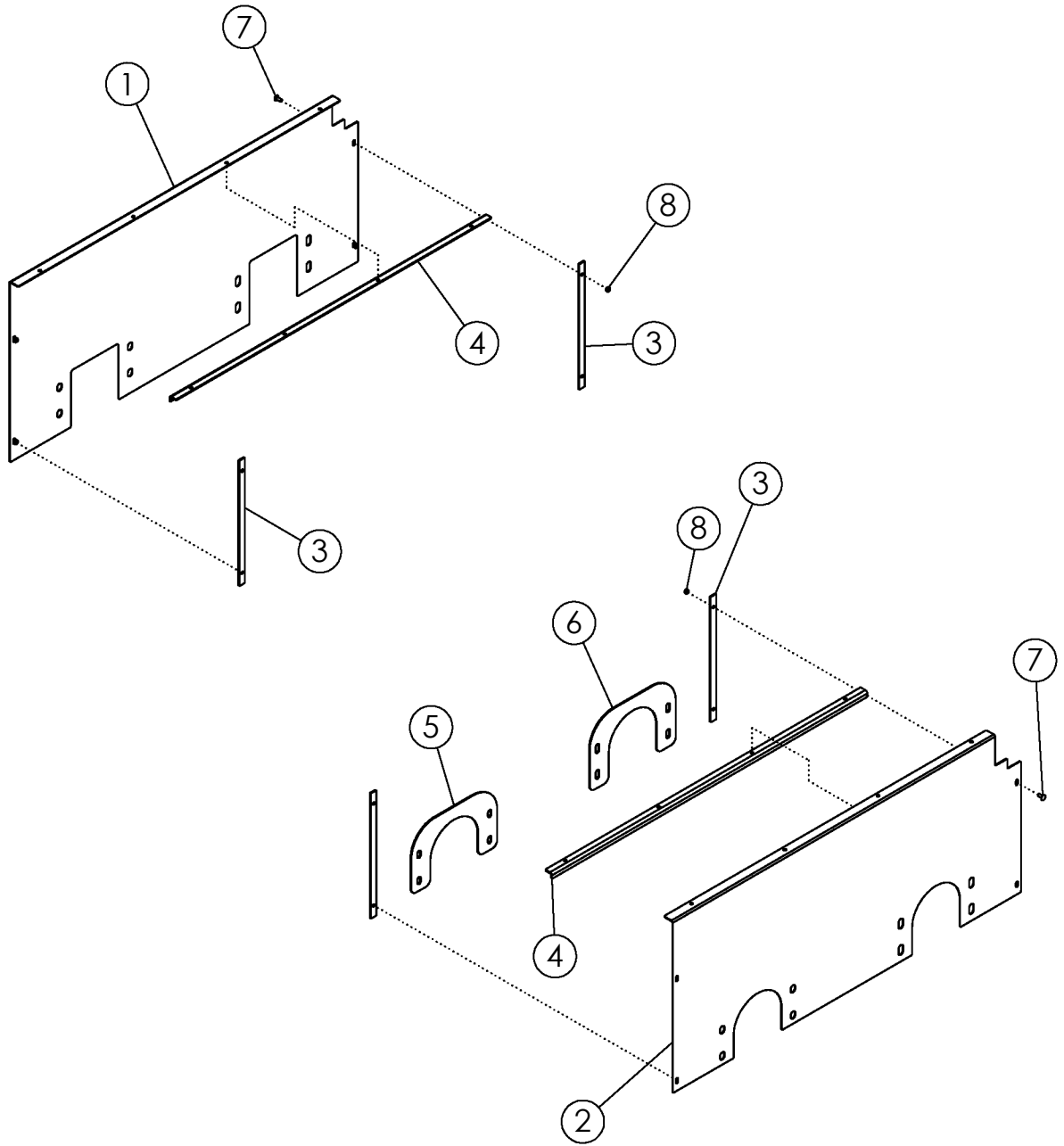



## SIDE PLASTIC ASSY

ITEM	PART NO.	DESCRIPTION	QTY
1	305283	LINER-RH 3750 DEF PLASTIC	1
2	305284	LINER-LH 3750 DEF PLASTIC	1
3	69968	PLATE-RETAINER VERT	4
4	305286	PLATE- TOP RETAINER	2
5	69969	PLATE-LH LOWER RETAINER	1
6	305285	PLATE-LH LOWER REAR RETAINER	1
7	59488	BOLT-CRG: .38 X 1.00 NC GR5 ZP	16
8	1016999	NUT-TOPLOCK: .38 NC GR5 ZP	16

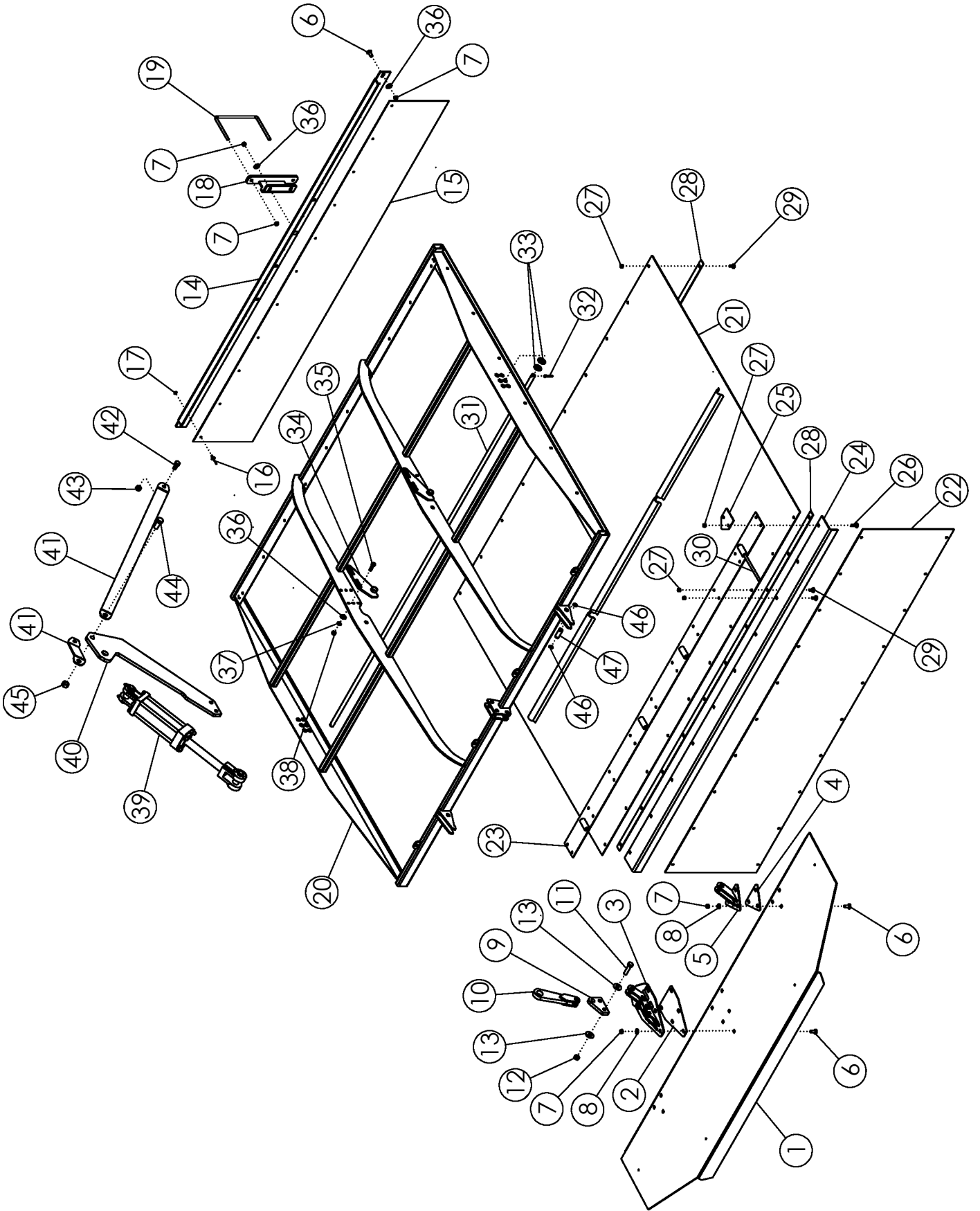

## TOP DOOR ASSY

ITEM	PART NO.	DESCRIPTION	QTY
1	305471	PLATE-SHROUD DOOR 8R	2
2	306089	PLATE-SPACER CENTER	2
3	306085	WLDMT-HINGE CENTER	2
4	306090	PLATE-SPACER OUTER	4
5	305655	WLDMT-HINGE SHROUD DOOR	4
6	59488	BOLT-CRG: .38 X 1.00 NC GR5 ZP	28
7	1016999	NUT-TOPLOCK: .38 NC GR5 ZP	40
8	1014608	WASHER-FLAT: SAE .38 ZP	22
9	305771	PLATE-HINGE LUG	2
10	305629	WLDMT-DOOR LINKAGE	2
11	1011609	BOLT-HEX: .50 X 2.00 NC GR5 ZP	8
12	1027461	NUT-TOPLOCK: .50 NC GR5 ZP	8
13	1014443	WASHER-FLAT: .50 ZP	16
14	305488	PLATE-REAR SUPPORT 8R	2
15	305487	LINER-REAR 8R	2
16	1011974	RIVET-POP: .19 X .55 ZP	22
17	306105	WASHER-RIVET BLIND .19"	22
18	69111	WLDMT-DOOR SUPPORT	2
19	64244	U-BOLT: .375 X 5.13 X 8.00 X 5.13 ZP	2
20	306736	WLDMT-8R TOP DOOR, TARP	2
21	306737	TARP-8R TOP DOOR	2
22	307555	TARP-8R FRONT SHORT	2
23	306739	WLDMT-TENSION	2
24	306740	PLATE-TENSION LOWER	2
25	307535	PLATE-TARP DOOR CLAMP	4
26	1017255	BOLT-CRG: .31 X 1.00 NC GR5 ZP	40
27	1030700	NUT-TOPLOCK: .31 NC GR5 ZP	40
28	306741	PLATE-REAR TARP CLAMP	4
29	65702	BOLT-CRG: .31 X .75 NC GR5 ZP	20
30	306980	BOLT-HEX: .38 X 8.00 NC GR5	8
31	306742	ROD-8R TARP SUPPORT	2
32	1012375	PIN-COTTER: .19 X 1.50 ZP	6
33	1013004	WASHER-FLAT: SAE .63 ZP	4
34	307310	WLDMT-TARP ROD ADJ	4
35	1011601	BOLT-HEX: .38 X 1.25 NC GR5 ZP	8
36	1011828	WASHER-FLAT: .38 ZP	14
37	1011586	WASHER-LOCK: .38 ZP	8
38	1030296	NUT-HEX: .38 NC GR5 NP	8
39	58890	CYLINDER-HYDRAULIC 3 X 8" 3000	2
40	305253	PLATE-DOOR CYLINDER LIFT	2
41	306751	PLATE-LIFT STRAP 8R	4

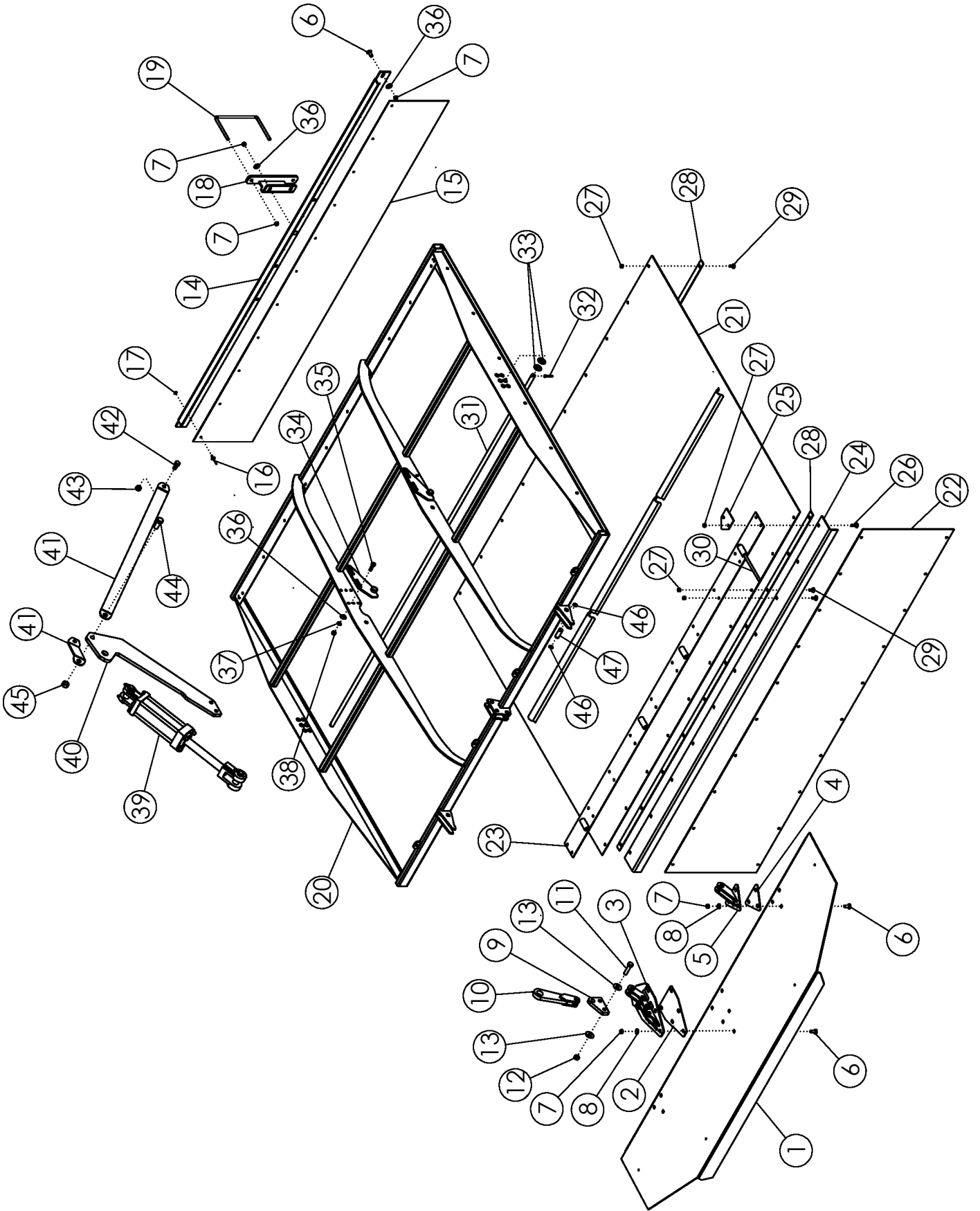

## TOP DOOR ASSY (CONTINUED)

ITEM	PART NO.	DESCRIPTION	QTY
42	1011096	BOLT-HEX: .50 X 1.00 NC GR5 ZP	4
43	1011500	NUT-CENTERLOCK: .50 NC GR2 ZP	4
44	1014349	BOLT-HEX: .63 X 1.50 NC GR5 ZP	2
45	59316	NUT-CENTERLOCK: .625 NC GR5 ZP	2
46	305261	SNAP-RING .625" HD EXTERNAL ZP	28
47	305244	PIN-TOP DOOR ZP	14

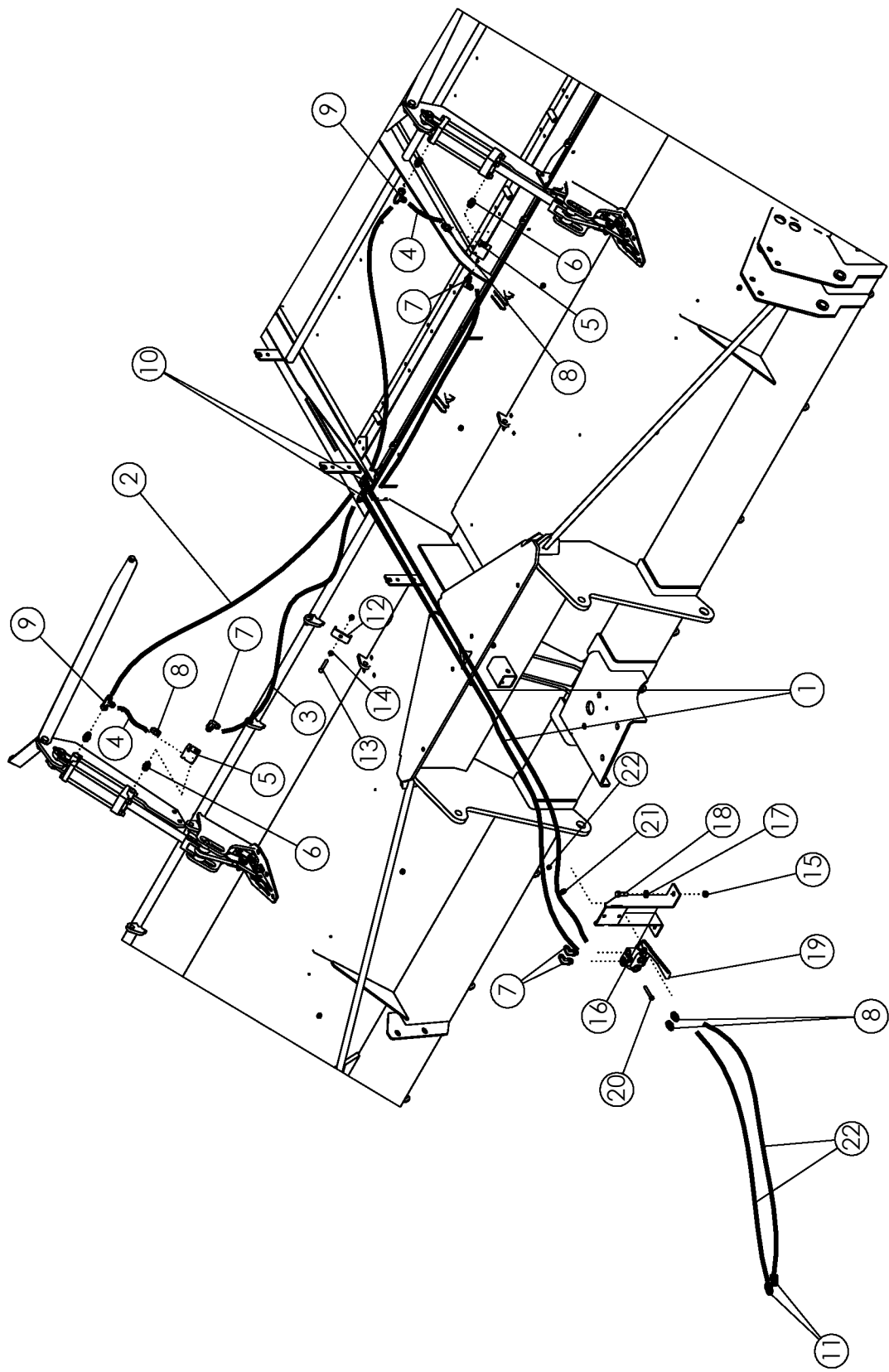

## TOP DOOR HYDRAULICS

ITEM	PART NO.	DESCRIPTION	QTY
1	72475	HOSE: .38 X 30 8MB-8FJX	2
2	305636	HOSE: .38 X 82 8FJX-8FJX	2
3	305637	HOSE: .38 X 72 8FJX-8FJX	2
4	305345	HOSE: .38 X 8.25 8FJX-8FJX	2
5	305404	VALVE-CHECK SINGLE PILOT OPERATED	2
6	305343	FTG-ADAPTER: 8MB-8MB	2
7	58560	FTG-ELBOW: 8MB-8MJ-90	2
8	56226	FTG-ADAPTER: 8MB-8MJ	4
9	63015	FTG-TEE: 8MJ-8FJX-8MJ	2
10	57667	FTG-TEE: 8MJ-8MJ-8MJ	2
11	36290	PIONEER TIP 8010-15P (#8 ORB)	2
12	50714	CLAMP 1/2" ZP	4
13	1019828	BOLT-HEX: .38 X 2.75 NC GR5 ZP	4
14	1011586	WASHER-LOCK: .38 ZP	4
15	1027461	NUT-TOPLOCK: .50 NC GR5 ZP	2
16	305794	WLDMT-SELECTOR MOUNT	1
17	1011584	WASHER-FLAT: SAE .50 ZP	1
18	1011607	BOLT-HEX: .50 X 1.50 NC GR5 ZP	2
19	58470	VALVE-SELECTOR PAINTED	1
20	59390	BOLT-HEX: .38 X 2.25 NC GR5 ZP	2
21	1011828	WASHER-FLAT .38 ZP	2
22	300053	HOSE: .50 X 108 8MB-8FJX	2

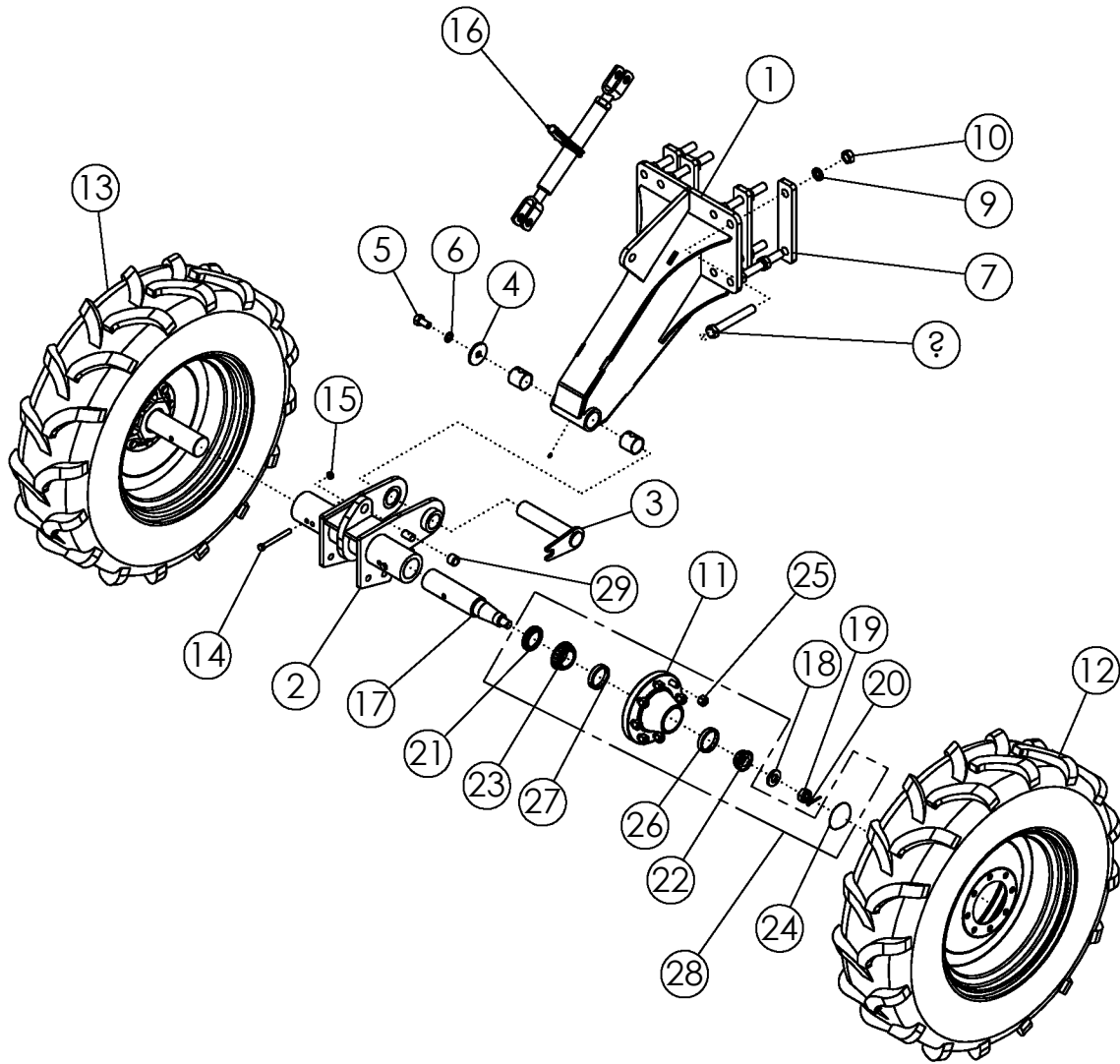



## ASSY-STRUT STANDARD 11.2-24 PIVOT

ITEM	PART NO.	DESCRIPTION	QTY
1	306019	ASSY-STRUT STANDARD PIVOT	1
	1011748	ZERK - GREASE	1
	73466	BUSHING-SPRING 2.25 X 2.0 X 2.0 L	2
2	305561	WLDMT-SPINDLE RECEIVER 22"	1
	305562	WLDMT-SPINDLE RECIEVER 44" (NOT SHOWN)	
	306704	WLDMT-SPIDLE RECIEVER 36" (NOT SHOWN)	
3	305573	WLDMT-DEF STRUT FLAG PIN	1
4	305575	PLATE-PIVOT POINT END CAP ZP	1
5	58367	BOLT-HEX: .75 X 1.50 NC GR5 ZP	1
6	1012061	WASHER-LOCK: .75 ZP	1
7	58408	BAR - BOLTING	4
8	1018839	BOLT-HEX: 1.0 x 7.00 NC GR8 ZP	8
9	1013539	WASHER-LOCK: 1.00 ZP	8
10	1012664	NUT-HEX: 1.00 NC GR2 ZP	8
11	53623	HUB-WHEEL 8-BOLT	2
12	56986	HRV RH WHEEL	1
13	63992	HRV LH WHEEL	1
14	1011618	BOLT-HEX: .50 X 5.00 NC GR5 ZP	2
15	1027461	NUT-TOPLOCK: .50 NC GR5 ZP	2
16	52407	RATCHET JACK-PAINTED	1
17	52954	SPINDLE-STANDARD	2
18	1030728	WASHER-SPINDLE: 1.06IDX2.13OD	2
19	1030726	NUT-SPINDLE: 1.00 NF NP	2
20	1030797	PIN-COTTER: .19 X 1.75 NP	2
21	53619*	SEAL	1
22	53620*	BEARING-CONE	1
23	53621*	CONE-BEARING	1
24	53624*	HUB CAP	1
25	53625*	NUT-WHEEL .625-18NF	8
26	53622**	BEARING-CUP INNER	1
27	52243**	BEARING-CUP OUTER	1
28	69018	ASSY-HUB	2
29	45572	SPRING BUSHING 1.25 X 1 X 1	1

\* INCLUDED IN ITEM 28

\*\*INCLUDED IN ITEM 11

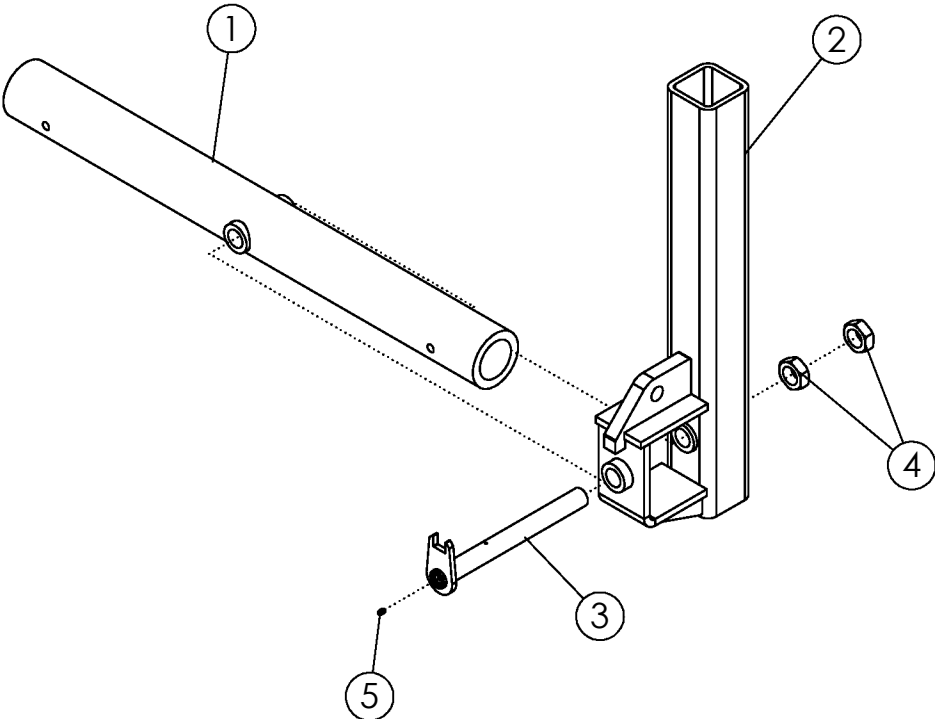

## **OSCILLATING SPINDLE HOUSING ASSEMBLY**

<b>ITEM</b>	<b>PART NO.</b>	<b>DESCRIPTION</b>	<b>QTY</b>
1	69438	WLDMT-OSC TUBE	1
2	69444	WLDMT-OSC STRUT	1
3	69446	WLDMT-FLAG PIN ZP	1
4	65864	NUT-JAM: 1.25 NF GR2 ZP	2
5	1011748	ZERK - GREASE	1

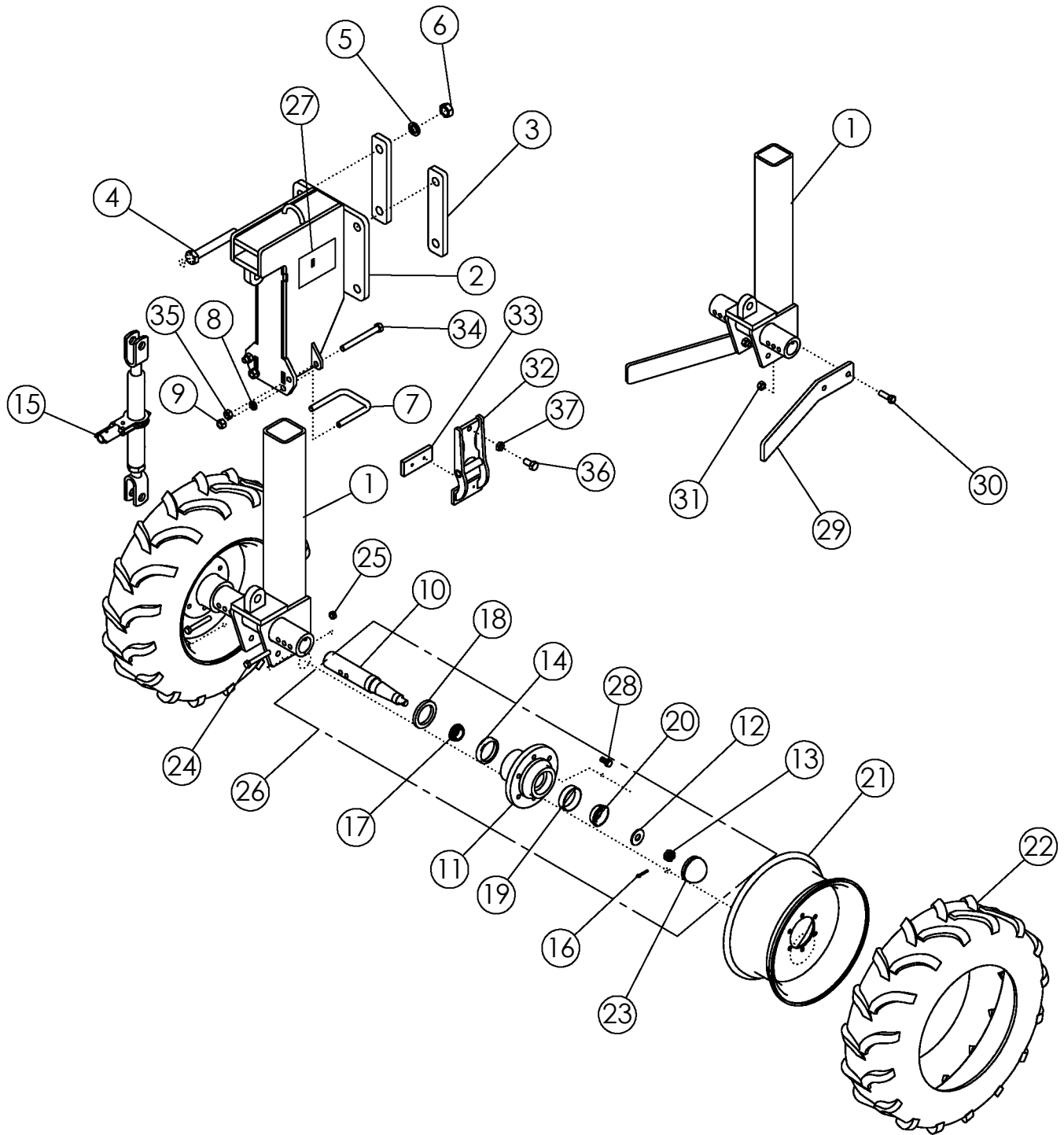

## STANDARD REAR STRUTS - 7.60 X 15 TIRES

ITEM	PART NO.	DESCRIPTION	QTY
1	58281	WLDMT-SPINDLE HOUSING	1
	64402	WLDMT-SPINDLE HOUSING- 6" OFFSET RH	1
	64406	WLDMT-SPINDLE HOUSING- 6" OFFSET LH	1
2	63559	WLDMT-STD STRUT UPPER	1
3	58408	BAR - BOLTING	2
4	1018839	BOLT-HEX: 1.00 X 7.00 NC GR8 ZP	4
5	1013539	WASHER-LOCK: 1.00 ZP	4
6	1012664	NUT-HEX: 1.00 NC GR2 ZP	4
7	60547	U-BOLT: .63 X 5.25 X 4.00 X 5.25	1
8	1011813	WASHER-LOCK: .63 ZP	2
9	1011578	NUT-HEX: .63 NC GR2 ZP	2
10	52138*	SPINDLE	2
11	52247*	HUB-WHEEL 6-BOLT	2
12	1012377*	WASHER-SPINDLE: .81 X 2.00 NP	2
13	1012376*	NUT-SLOTTED: .75 NF GR5 NP	2
14	52243*	CUP-BEARING INNER	2
15	52407	RATCHET JACK-PAINTED	1
16	1012375*	PIN-COTTER: .19 X 1.50 NP	2
17	52245*	CONE-BEARING INNER	2
18	52242*	SEAL	2
19	52244*	CUP-BEARING OUTER	2
20	52246*	CONE-BEARING OUTER	2
21	52411	WHEEL 6.00-15 6 BOLT	2
22	52410	TIRE 7.60-15 I-3 6 PLY	2
	68974	TUBE-REPAIR 7.60-15 (NOT SHOWN)	AR
23	52241*	CAP-HUB	2
24	1011612	BOLT-HEX: .50 X 3.50 NC GR5 ZP	2
25	1027461	NUT-TOPLOCK: .50 NC GR5 ZP	2
26	52116	ASSY HUB & SPINDLE	2
27	52248	DECAL-CAUTION	1
28	1013426*	BOLT-LUG: .50 X 1.00 NF GR5 ZP	12
29	305642	PLATE-SCRAPER 7.6-15 DEF	2
30	1011623	BOLT-HEX: .63 X 2.00 NC GR5 ZP	4
31	1016595	NUT-TOPLOCK: .63 NC GR5 ZP	4
32	69956	WLDMT- DEF STRUT CLAMP	2
33	69971	PLASTIC-STRUT CLAMP	2
34	1013068	BOLT-HEX: .63 X 6.00 NC GR5 ZP	2
35	1016595	NUT-TOPLOCK: .63 NC GR5 ZP	2
36	1030703	BOLT-HEX: .63 X 1.25 NF GR5 ZP	2
37	66336	NUT-JAM: .63 NF GR2 ZP	2
38	69987	SCREW-MACH: FH-TORX .25-20 X 1.00 (NOT SHOWN)	4

\* Items are included in Item 26

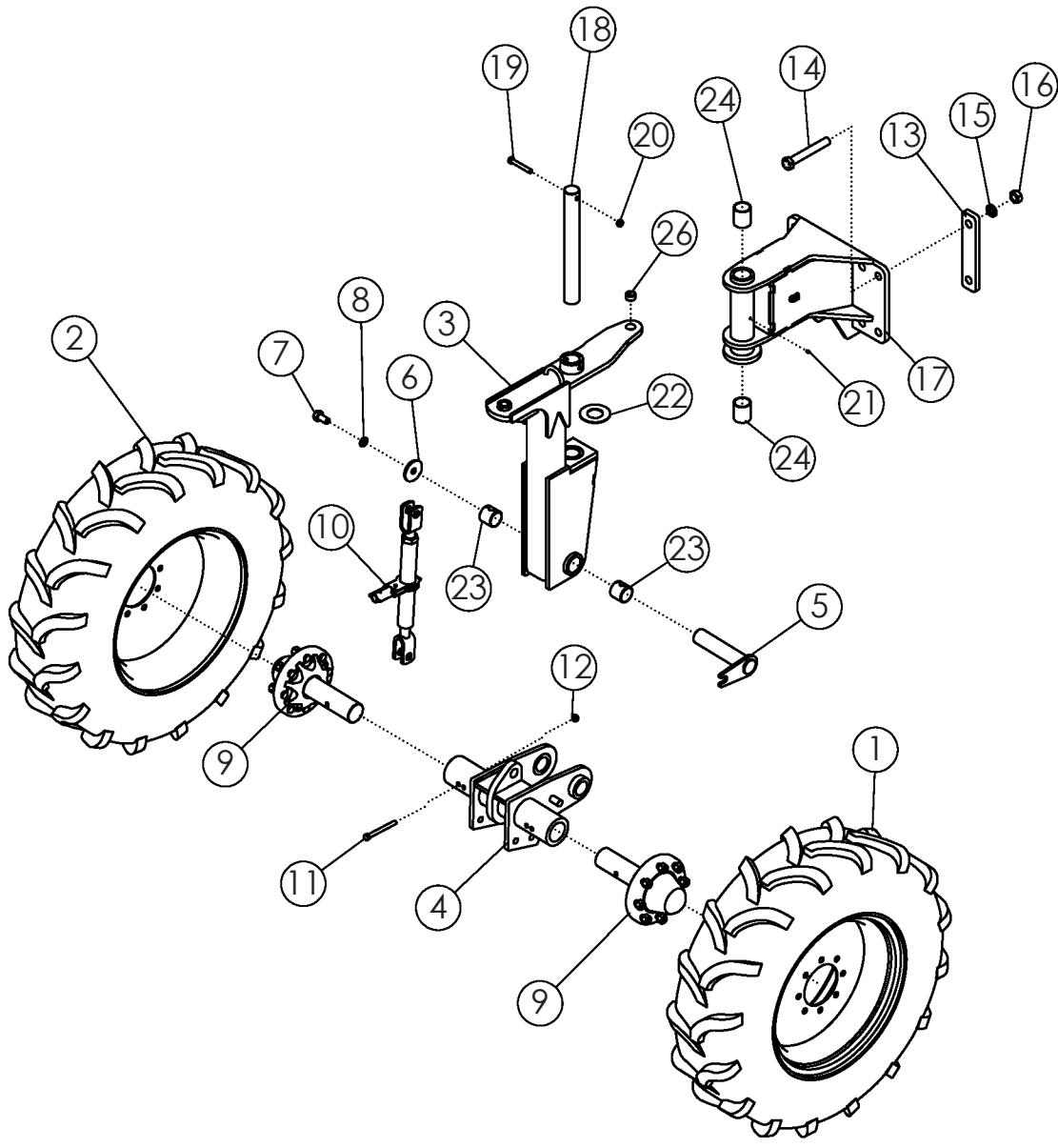

## ASSY-STEERABLE STRUT UPPER

ITEM	PART NO.	DESCRIPTION	QTY
1	56986	TIRE-MNTD: 11.2-24 10PLY R1 RH	1
2	63992	TIRE-MNTD: 11.2-24 10PLY R1 LE	1
3	305560*	WLDMT-STRUT UPPER	1
4	305561	WLDMT-SPINDLE RECEIVER 22"	1
	305562	WLDMT-SPINDLE RECEIVER 44"	
5	305573	WLDMT-DEF STRUT FLAG PIN	1
6	305575	PLATE-PIVOT POINT END CAP ZP	1
7	58367	BOLT-HEX: .75 X 1.50 NC GR5 ZP	1
8	1012061	WASHER-LOCK: .75 ZP	1
9	53167	ASSY-HUB & SPINDLE: 8 BOLT W/ZERK	2
10	52407	RATCHET JACK-PAINTED	1
11	1011618	BOLT-HEX: .50 X 5.00 NC GR5 ZP	1
12	1027461	NUT-TOPLOCK: .50 NC GR5 ZP	1
13	58408	BAR - BOLTING	4
14	1018839	BOLT-HEX: 1.0 X 7.00 NC GR8 ZP	4
15	1013539	WASHER-LOCK: 1.00 ZP	4
16	1012664	NUT-HEX: 1.00 NC GR2 ZP	4
17	305925-1*	ASSY-PIVOT MOUNT	1
18	58274*	SHAFT	1
19	1011612*	BOLT-HEX: .50 X 3.50 GR5 ZP	1
20	1027461*	NUT-TOPLOCK: .50 NC GR5 ZP	1
21	1011748*	ZERK - GREASE	2
22	305586*	BUSHING-THRUST 2.062 X 4.00 X .125	1
23	73466*	BUSHING-SPRING 2.25 X 2.0 X 2.0 L (REF)	2
24	59204*	BUSHING-BORE 2.5 X 2.015	2
25	45572	SPRING BUSHING 1.25 X 1 X 1	1
26	307240*	BUSHING-SPRING 1.25 X 1.0 X 0.75	1

Parts marked by \* are included in 305924

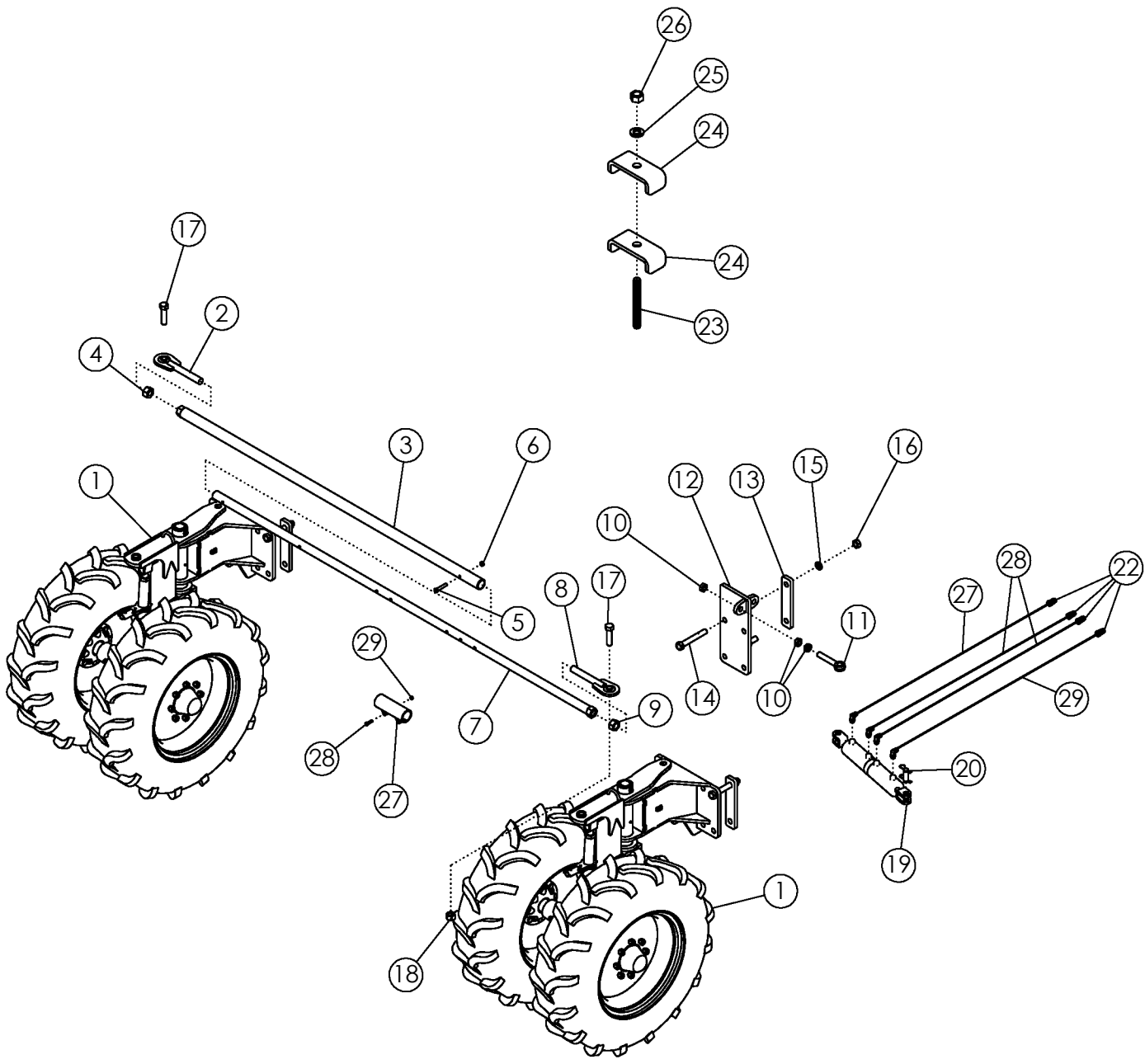



## STRUTS-STEERABLE 11.2 X 24 22" CENTERING

ITEM	PART NO.	DESCRIPTION	QTY
1	305922	ASSY-STURT STEERABLE 11.2 X 24 22" PIVOT	2
2	58203	WLDMT-TIE ROD END LH	1
3	58416	WLDMT-TIE ROD 70" FEMALE	1
	306577	WLDMT-TIE ROD 85" FEMALE	
4	1030729	NUT-HEX: 1.25 NC GR2 LH ZP	1
5	1016858	BOLT-HEX: .50 X 2.75 NC GR5 ZP	1
6	1027461	NUT-TOPLOCK: .50 NC GR5 ZP	1
7	58415	WLDMT-TIE ROD 70" MALE 6 ROW	1
	306581	WLDMT-TIE ROD 107" MALE 8R/12ROW	
8	58186	WLDMT-TIE ROD END RH	1
9	1011621	NUT-HEX: 1.25 NC GR2 ZP	1
10	1026880	NUT-HEX JAM: 1.00 NC GR2 ZP	3
11	62081	BOLT-EYEBOLT 1" X 6" GR 8	1
12	306732	WLDMT-CYLINDER BRACKET ADJ	1
13	58408	BAR - BOLTING	2
14	1018839	BOLT-HEX: 1.0 x 7.00 NC GR8 ZP	4
15	1013539	WASHER-LOCK: 1.00 ZP	4
16	1012664	NUT-HEX: 1.00 NC GR2 ZP	4
17	1032276	BOLT-HEX: 1.0 X 3.50 NC GR8 ZP	2
18	1016970	NUT-TOPLOCK: 1.00 NC GR8 ZP	2
19	69200	CYLINDER HYD 3 X 4 4 PORT 24.5 CLOSED	1
	305293	SEAL KIT 69200 2015 AND NEWER	
20	69167	PIN-CYLINDER W/CLIPS 1.00 X 2.25	2
21	58560	FTG-ELBOW: 8MB-8MJ-90	4
22	36290	PIONEER TIP 8010-15P (#8 ORB)	4
23	65379	STUD-.375 X 3.00 UNC ZP	4
24	50714	CLAMP .50 ZP	8
25	1011586	WASHER-LOCK: .38 ZP	4
26	1011576	NUT-HEX: .38 NC GR2 ZP	4
27	69557	WLDMT-TIE ROD CLAMP 6ROW	1
	306579	WLDMT-TIE ROD CLAMP 8R/12ROW	
28	1011302	BOLT-HEX: .38 X 1.50 NC GR5 ZP	2
29	1016999	NUT-TOPLOCK: .368 NC ZP	2

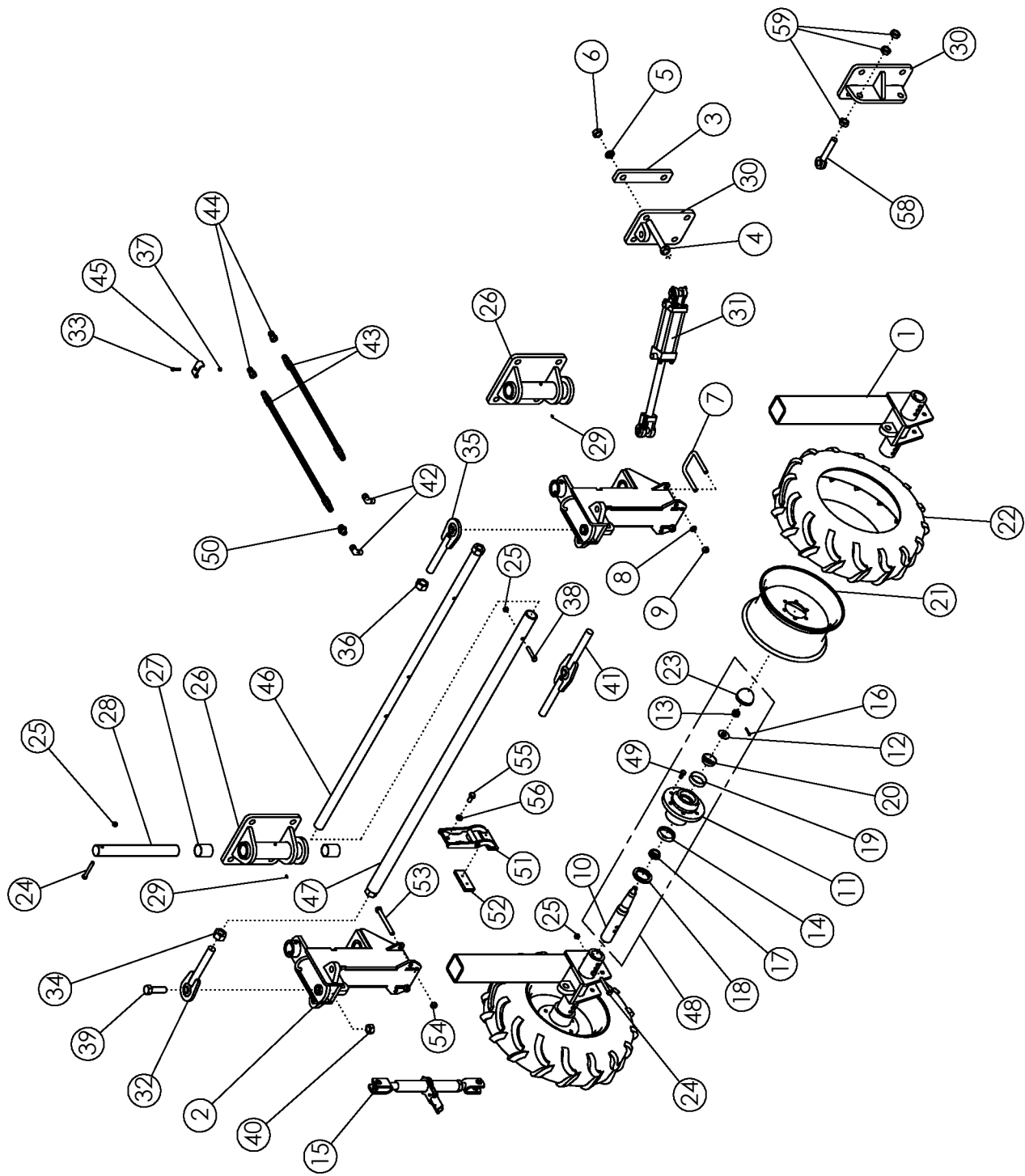

## STEERABLE REAR STRUTS - 7.60 X 15 TIRES

ITEM	PART NO.	DESCRIPTION	QTY
1	58281	WLDMT-SPINDLE HOUSING	4
2	63558	WLDMT-STEERABLE STRUT UPPER	4
3	58408	BAR - BOLTING	10
4	1018839	BOLT-HEX: 1.00 X 7.00 NC GR8 ZP	20
5	1013539	WASHER-LOCK: 1.00 ZP	20
6	1012664	NUT-HEX: 1.00 NC GR2 ZP	20
7	60547	U-BOLT: .63 X 5.25 X 4.00 X 5.25	4
8	1011813	WASHER-LOCK: .63 ZP	8
9	1011578	NUT-HEX: .63 NC GR2 ZP	8
10	52138*	SPINDLE	8
11	52247*	HUB-WHEEL 6 BOLT	8
12	1012377*	WASHER-SPINDLE: .81 X 2.00 NP	8
13	1012376*	NUT-SLOTTED: .75 NF GR5 NP	8
14	52243*	BEARING CUP-INNER	8
15	52407	RATCHET JACK-PAINTED	4
16	1012375*	PIN-COTTER: .19 X 1.50 NP	8
17	52245*	BEARING CONE-INNER	8
18	52242*	SEAL	8
19	52244*	BEARING-CUP OUTER	8
20	52246*	BEARING-CONE OUTER	8
21	52411	WHEEL 6.00-15 6 BOLT	8
22	52410	TIRE 7.60-15 I-3 6 PLY	8
	68974	TUBE-REPAIR 7.60-15 (NOT SHOWN)	AR
23	52241*	CAP-HUB	8
24	1011612	BOLT-HEX: .50 X 3.50 GR5 ZP	12
25	1027461	NUT-TOPLOCK: .50 NC GR5 ZP	15
26	58283	WLDMT-PIVOT MOUNT	4
27	59204	BUSHING - BORED	8
28	58274	SHAFT	4
29	1011748	ZERK - GREASE	8
30	58410	WLDMT-CYLINDER BRACKET	1
	306727	WLDMT-ADJ CYL BRACKET 7.6 TIRES	
31	62319	CYLINDER HYDRAULIC 2 X 4	1
	69654	SEAL KIT FOR 62319	
32	58203	WLDMT-TIE ROD END LH	1
33	1014124	BOLT-HEX: .31 X 1.50 NC GR5 ZP	2
34	1030729	NUT-HEX: 1.25 NC GR2 LH ZP	3
35	58186	WLDMT-TIE ROD END RH	1
36	1011621	NUT-HEX: 1.25 NC GR2 ZP	3
37	1030700	NUT-TOPLOCK: .31 NC GR5 ZP	2

CONTINUED

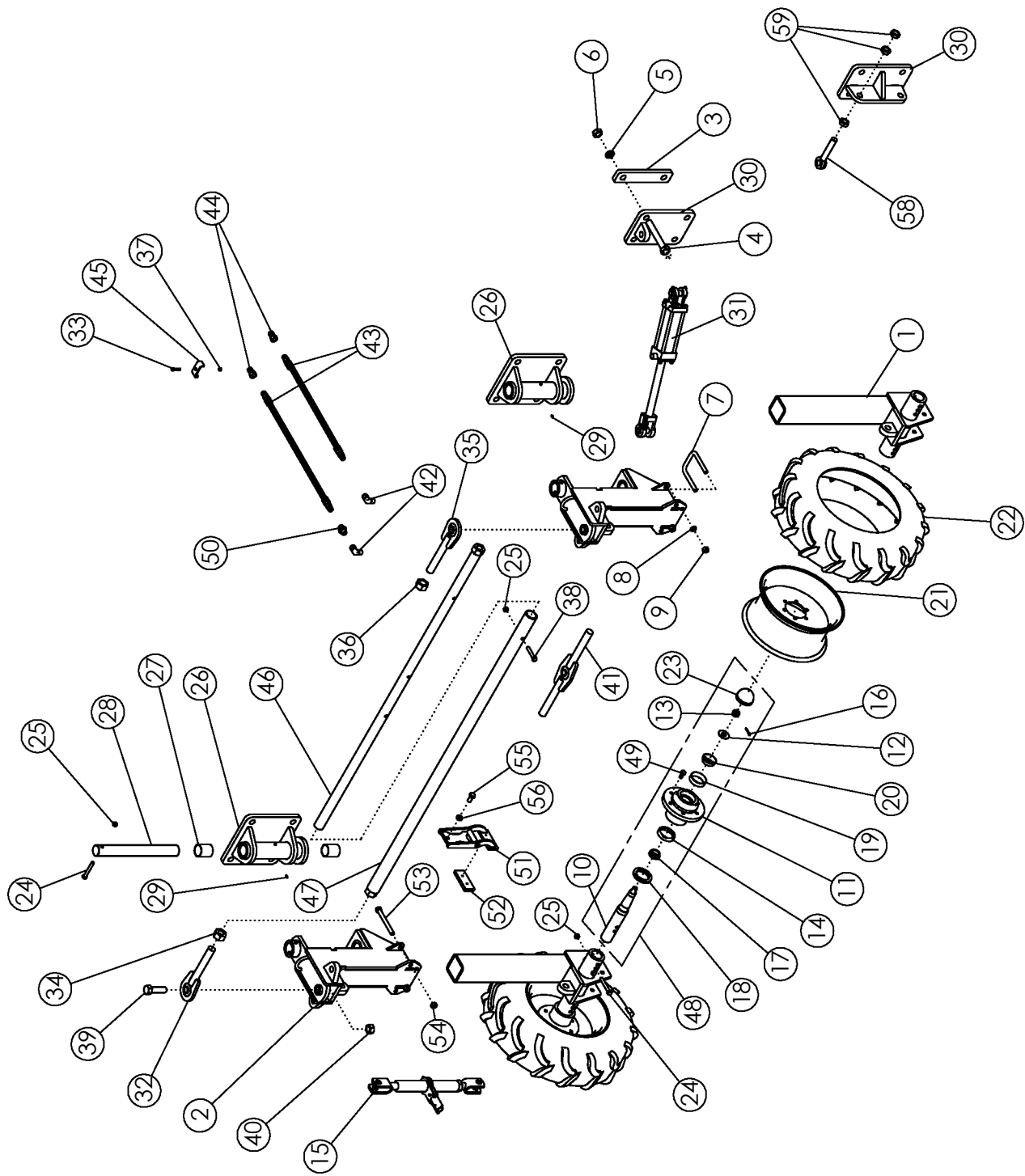

## STEERABLE REAR STRUTS - 7.60 X 15 TIRES (CONTINUED)

ITEM	PART NO.	DESCRIPTION	QTY
38	1016858	BOLT-HEX: .50 X 2.75 NC GR5 ZP	3
39	1011626	BOLT-HEX: 1.00 X 3.50 NC GR5 ZP	4
40	1016969	NUT-TOPLOCK: 1.00 NC GR5 ZP	4
41	58205	WLDMT-TIE ROD END DOUBLE	2
42	1026247	FTG-ELBOW: 6MP-8MJ90	2
43	300032	HOSE: .50 X 336 8MB-8FJX	2
44	36290	PIONEER TIP 8010-15P (#8 ORB)	2
45	50714	CLAMP 1/2" ZP	2
46	58418	WLDMT-TIE ROD MALE 40"	3
47	58417	WLDMT-TIE ROD FEMALE 40"	3
48	52116	ASSY-HUB & SPINDLE	8
49	1013426*	BOLT-LUG: .50 X 1.00 NF GR5 ZP	24
50	300030	FTG-RESTRICTOR 8MJ-8FJ .062	1
51	69956	WLDMT- DEF STRUT CLAMP	4
52	69971	PLASTIC-STRUT CLAMP	4
53	1013068	BOLT-HEX: .63 X 6.00 NC GR5 ZP	4
54	1016595	NUT-TOPLOCK: .63 NC GR5 ZP	4
55	1030703	BOLT-HEX: .63 X 1.25 NF GR5 ZP	4
56	66336	NUT-JAM: .63 NF GR2 ZP	4
57	69987	SCREW-MACH: .25-20 X 1.00 (NOT SHOWN)	8
58	62081	BOLT-EYEBOLT: 1.00 X 6.00 ZP GR8	1
59	1026880	NUT-JAM: 1.00 NC GR2 ZP	3

\* Items are included in Item 48

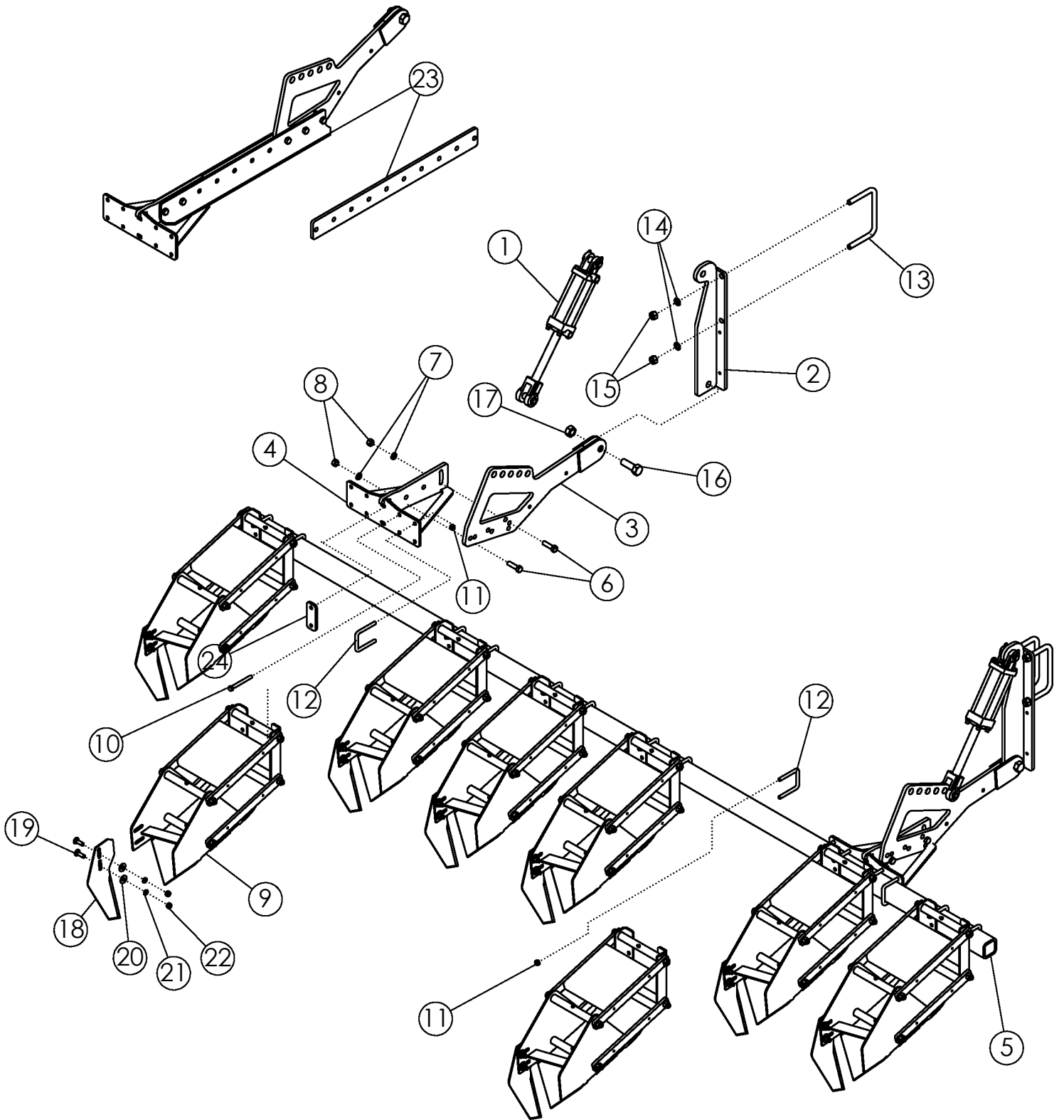

## SCALPER BAR ASSEMBLY

ITEM	PART NO.	DESCRIPTION	QTY	
			8R22	6R30
1	58890	CYLINDER HYDRAULIC 3 X 8	2	2
	301314	SEAL KIT FOR 58890 UNIVERSAL		
2	68239	WLDMT - MOUNT	2	2
3	69126	WLDMT-SCALPER ARM MNT	2	2
4	69127	WLDMT-BAR MNT BRACKET	2	2
5	51864	SCALPER BAR	1	1
6	1017526	BOLT-HEX .63 X 2.25 NC GR5 ZP	4	4
7	1011813	WASHER-LOCK: .63 ZP	4	4
8	1011578	NUT-HEX: .63 NC GR2 ZP	4	4
9	63462	ASSY-SCALPER BASKET	6	6
10	1013682	BOLT-HEX: .50 X 4.50 NC GR5 ZP	8	8
11	1027461	NUT-TOPLOCK: .50 NC GR5 ZP	44	36
12	69954	U-BOLT: .50 X 4.50 X 3 X 4.50	18	14
13	56263	U-BOLT: .75 X 5.5 X 8 X 5.5	4	4
14	1012061	WASHER-LOCK: .75 ZP	8	8
15	1011620	NUT-HEX: .75 NC GR2 ZP	8	8
16	1018007	BOLT-HEX: 1.0 X 3.00 NC GR5 ZP	2	2
17	1016969	NUT-TOPLOCK: 1.00 NC GR5 ZP	2	2
18	51782	SCALPER KNIFE-HEAT TREAT	8	6
19	1011660	BOLT-CRG: .50 X 1.50 NC GR5 ZP	16	12
20	1014443	WASHER-FLAT: .50 ZP	16	12
21	1011581	WASHER-LOCK: .50 ZP	16	12
22	1011577	NUT-HEX: .50 NC ZP	16	12
23	305183*	PLATE-SCALPER EXTENSION	4	4
	306101	PLATE-SCALPER EXT FLAT		
24	51551	BAR-BASKET MOUNTING	2	2

\*USED WITH LARGER TIRE OPTION

\*OPT. 306101 FLAT BAR USED IN TIGHT CLEARNCE SITUATIONS i.e. 44" STRUTS

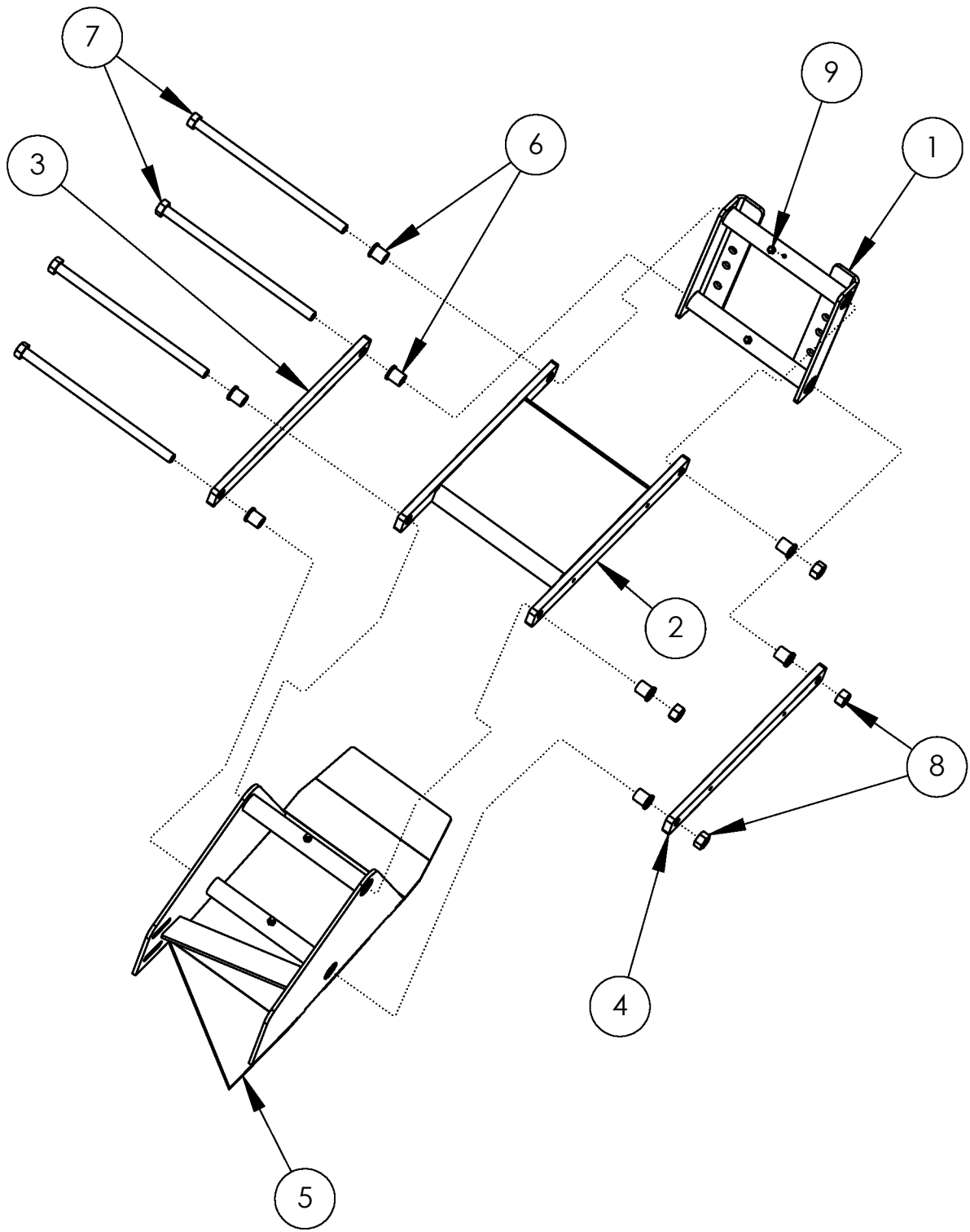



<b>SCALPER BASKET</b>			
<b>ITEM</b>	<b>PART NO.</b>	<b>DESCRIPTION</b>	<b>QTY</b>
1	63551	WLDMT-BASKET MOUNT	1
2	306849	WLDMT-UPPER LINK	1
3	63555	BAR-PARALLEL LINK	1
4	306848	BAR-PARALLEL LINK AHC THREADED PC	1
5	63550	WLDMT-BASKET FRAME	1
	306948*	WLDMT-BASKET FRAME V2	
6	306080	BUSHING-FLANGE: .628 X 8.16 X 1.4375L	8
7	306752	BOLT-HEX: .63 X 11.813 N GR5 ZP	4
8	59316	NUT-CENTERLOCK: .625 NC GR5 ZP	4
9	1011748	ZERK-GREASE .25 UNF STRAIGHT	4

\* Used in ASSY-SCALPER BASKET W/HARDWARE - SHORT

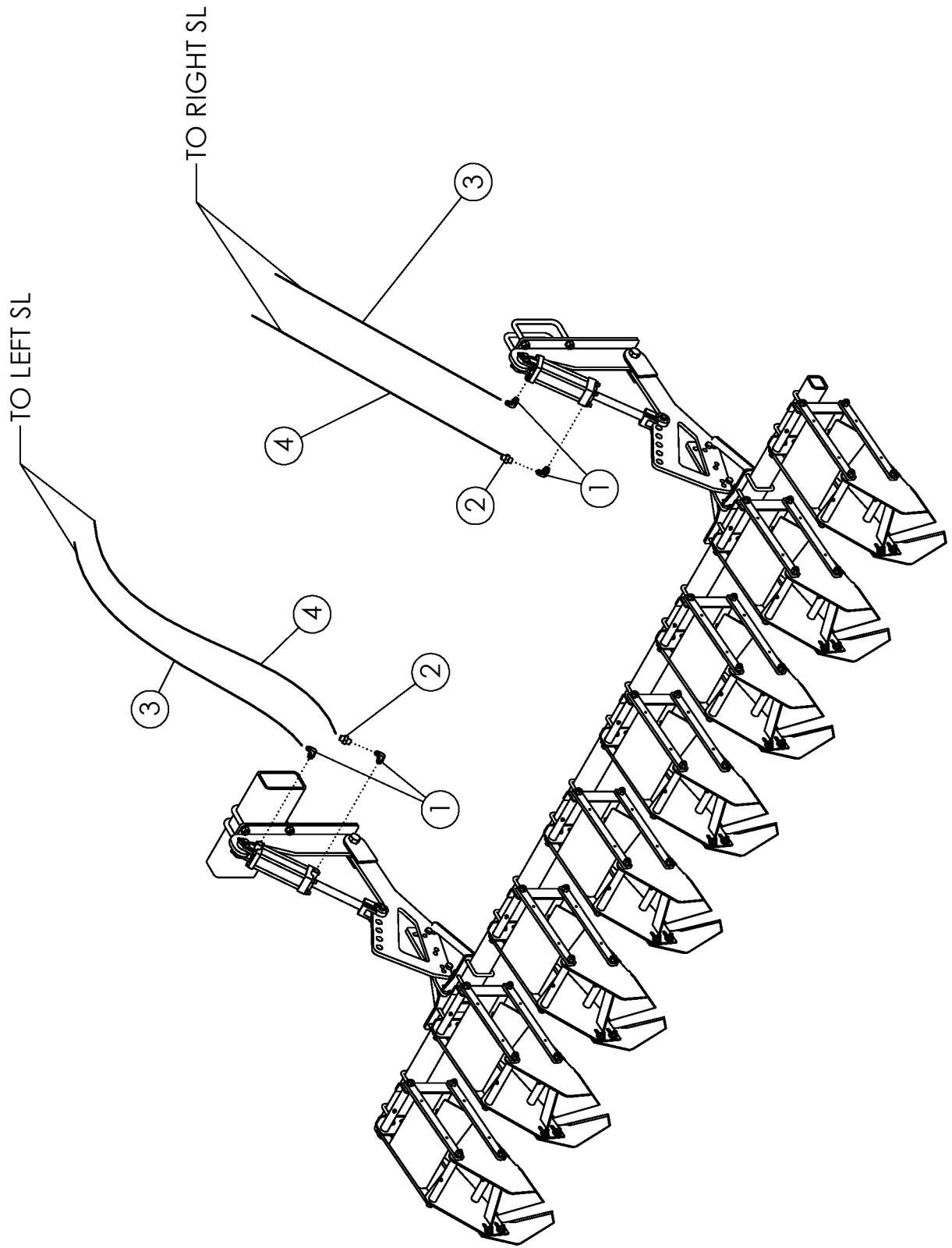

**SCALPER BAR MOUNTED ROW FINDER  
SCALPER HYDRAULICS**

<b>ITEM</b>	<b>PART NO.</b>	<b>DESCRIPTION</b>	<b>QTY</b>
1	58560	FTG-ELBOW: 8MB-8MJ-90	4
2	1019844	FTG-RESTRICTOR 8FJ-8MJ	2
3	63005	HOSE: .38 X 048 8FJX-8FJX	2
4	305961	HOSE: .38 X 058 8FJX-8FJX	2

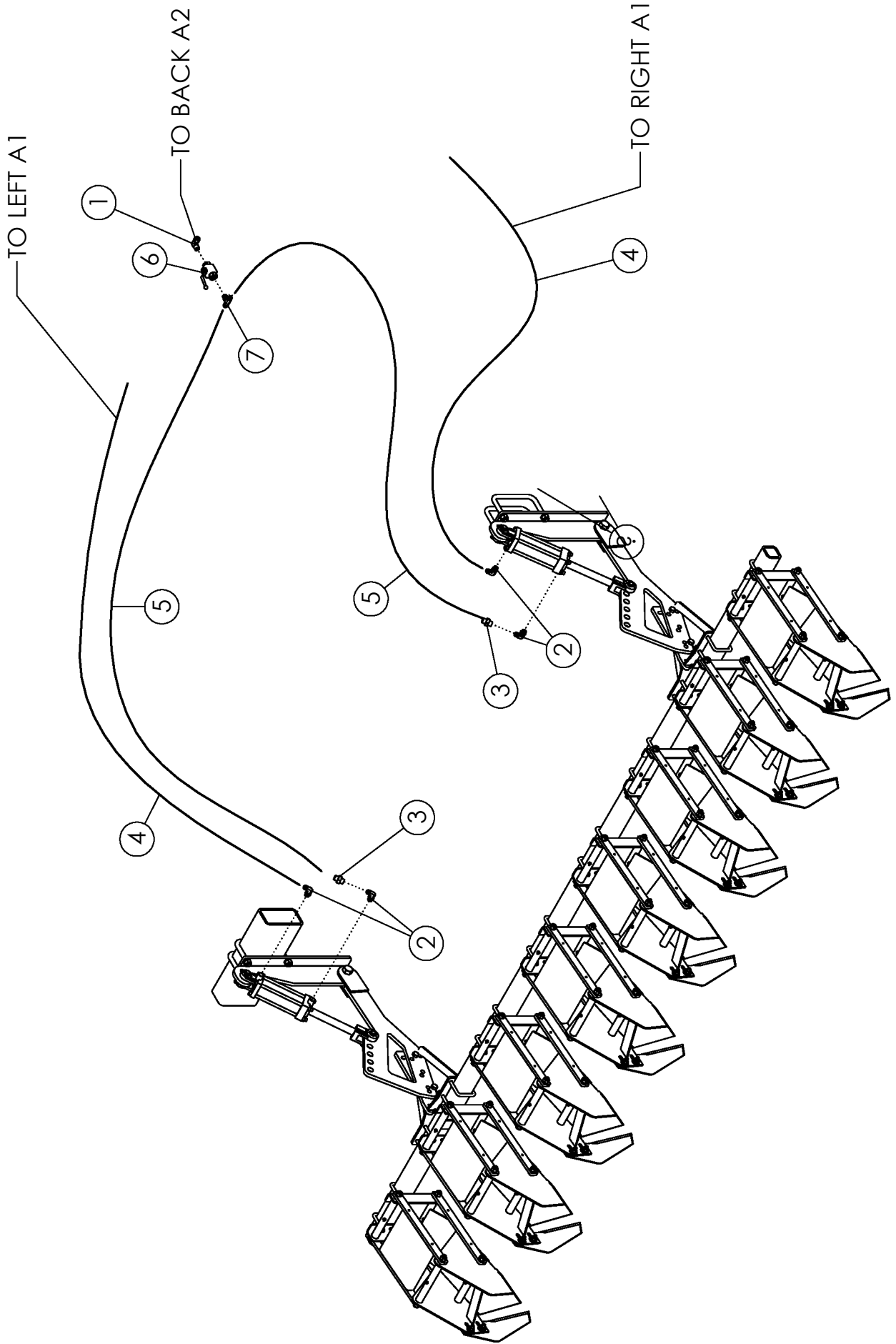

## FRAME MOUNTED ROW FINDER SCALPER HYDRAULICS

ITEM	PART NO.	DESCRIPTION	QTY
1	305581	FTG-ELBOW: 8MB-8FJX-90	1
2	58560	FTG-ELBOW: 8MB-8MJ-90	4
3	1019844	FTG-RESTRICTOR 8FJ-8MJ	2
4	63005	HOSE: .38 X 048 8FJX-8FJX	2
5	305961	HOSE: .38 X 058 8FJX-8FJX	2
6	305664	BALL VALVE	1
7	66602	FTG-TEE: 8MJ-8MJ-8MB	1

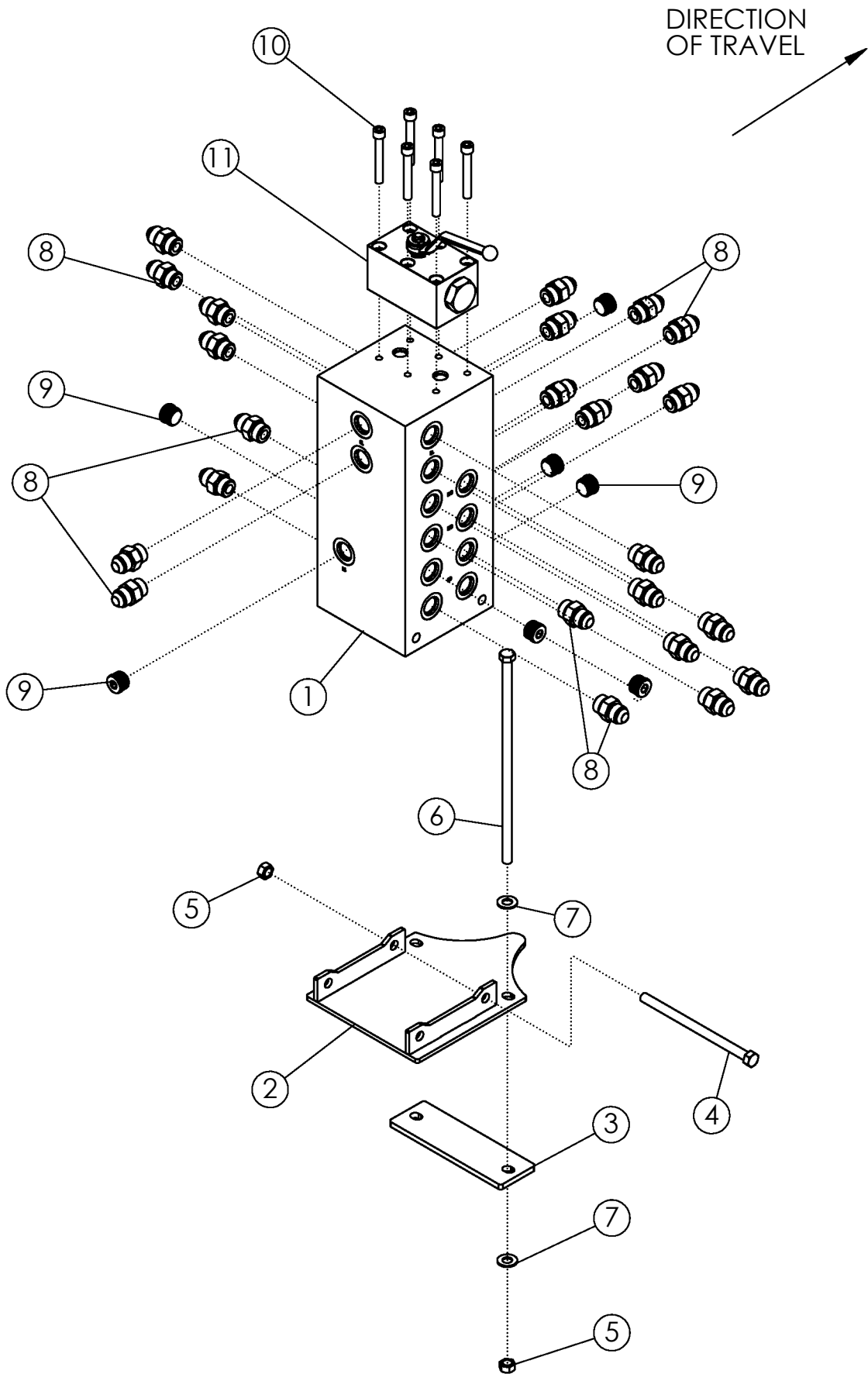

<b>VALVE BLOCK AND MOUNT</b>			
<b>ITEM</b>	<b>PART NO.</b>	<b>DESCRIPTION</b>	<b>QTY</b>
1	305960	HYDRAULIC BLOCK REAR DEF	1
2	305659	WLDMT-VALVE BLOCK MOUNT	1
3	305662	PLATE-VALVE BLOCK BOLTING	1
4	34925	BOLT-HEX: .38 X 6.00 NC GR5 ZP	2
5	1016999	NUT-TOPLOCK: .38 NC GR5 ZP	4
6	305663	BOLT-HEX: .38 X 10.00 NC GR5 ZP	2
7	1014608	WASHER-FLT: SAE .38 ZP	4
8	56226	FTG-ADAPTER: 8MB-8MJ	24
9	305666	FTG-PLUG: 8MB ALLEN DRIVE	AR
10	306097	BOLT-SHCS .31 X 2.25 NC ZP	6
11	306028	VALVE-BALL MANIFOLD MOUNT	1

**\*\* BLOCK SHOWN WITH ALL OPTIONS,  
IF NOT EQUIPPED BLOCK PORTS ARE  
PLUGGED WITH ITEM 9.**

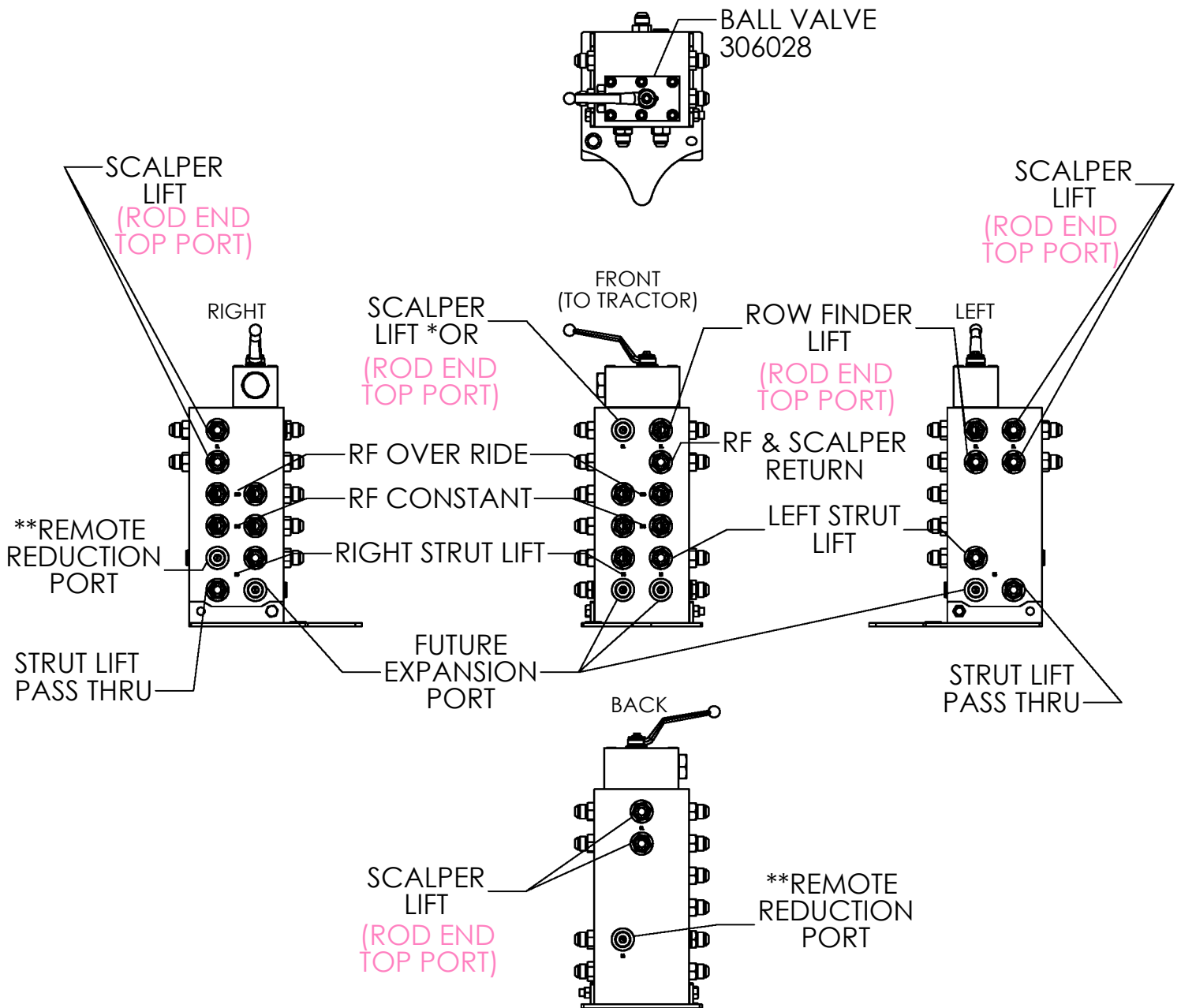

- \* EITHER THE SCALPER LIFT OR ROW FINDER LIFT PORT IS USED AND THE OTHER IS PLUGGED.
- IF A FRAME MOUNTED ROW FINDER IS USED, WITH OR WITHOUT SCALPER, THE ROW FINDER LIFT PORT IS USED IN CONJUNCTION WITH A BALL VALVE. ENABELING USE OF BOTH THE SCALPER (IF EQUIPPED) AND ROW FINDER OR ROW FINDER.
- IF A SCALPER WITHOUT FRAME MOUNTED ROW FINDER IS EQUIPPED THE SCALPER LIFT PORT IS USED AND NO BALL VALVE IS INSTALLED.

\*\* REMOTE REDUCTION PORT ALLOWS THE ROW FINDER CONSTANT FUNCTION TO BE TIED INTO THE STRUT LIFT FUNCTION TO ELIMINATE THE NEED FOR ONE ADDITIONAL HYDRAULIC REMOTE ON THE TRACTOR. IN THIS CONFIGURATION RETRACTING OR LOWERING THE STRUTS ALSO POWERS THE ROWFINDER CONSTANT FUNCTION. WHEN EXTENDING THE STRUTS A CHECK VALVE INSTALLED ON THE ROW FINDER PROHIBITS BACKWARDS OIL FLOW.

\*\* AN ALTERNATE OPTION TO REDUCE HYDRAULIC REMOTES REQUIRED WOULD BE TO HOOK UP THE ROW FINDER CONSTANT TO THE TRACTOR'S POWER BEYOND USING AN EXTERNAL FLOW CONTROL SET TO APPROXIMATELY 7 GPM.



# CROSS SECTIONAL BLOCK VIEW

FRONT VIEW

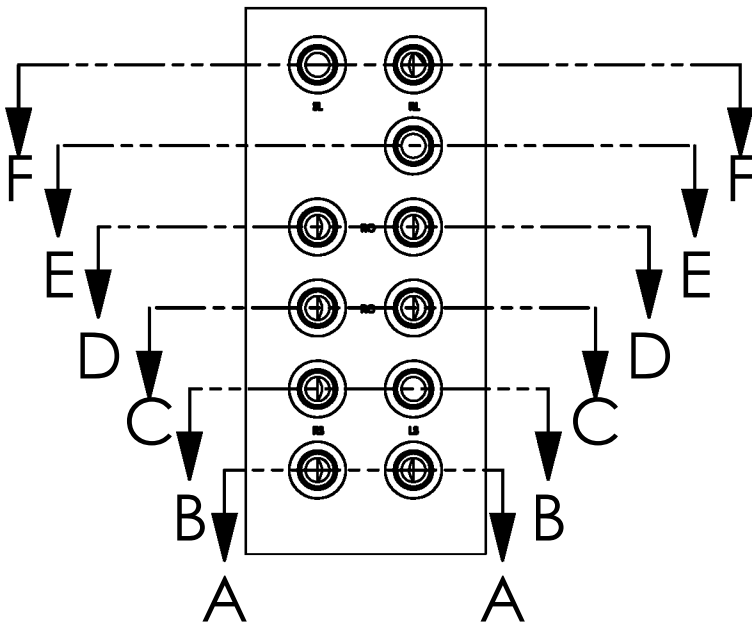

SECTION C-C

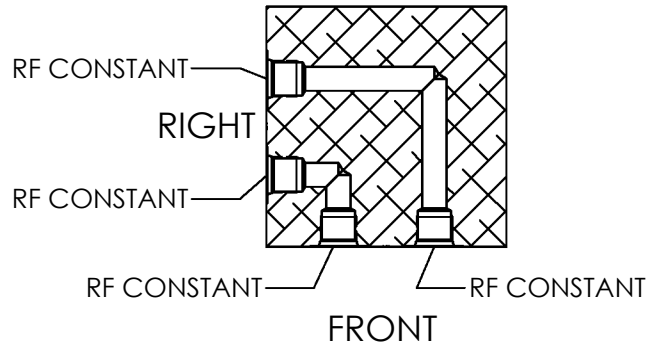

SECTION D-D

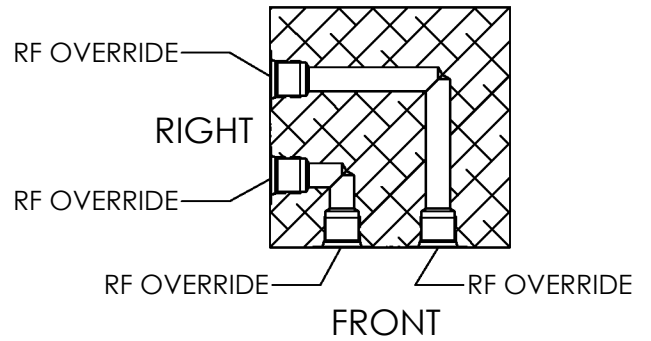

SECTION E-E

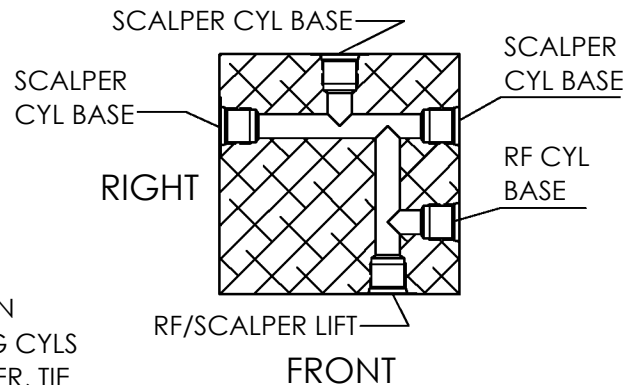

SECTION F-F

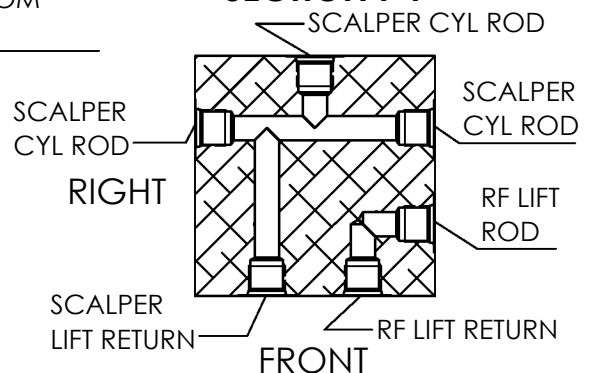

REPHASING PORT - CONNECT ROD END OF LARGER CYL TO BASE END OF SMALLER CYL FOR STD REAR LIFT

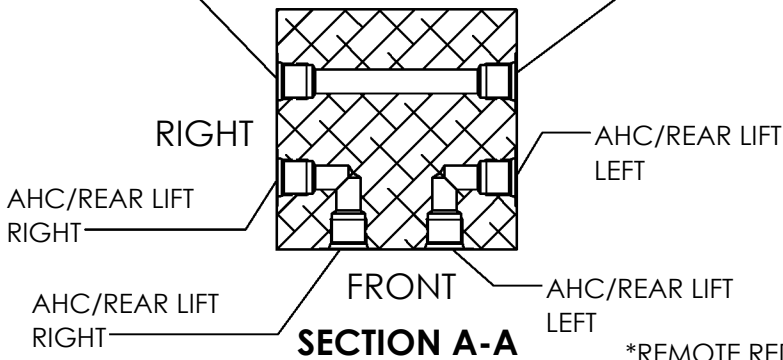

SECTION A-A

\*REMOTE REDUCTION PORT W/ REPHASING CYLS - IF RH CYL IS SMALLER, TIE THIS INTO RC OF THE STEERING BLOCK; IF LH CYL IS SMALLER, TIE THIS TO INPUT BOTTOM SUPPLY OF RF VALVE

\*REMOTE REDUCTION PORT W/ REPHASING CYLS - IF RH CYL IS SMALLER, TIE THIS INTO INPUT BOTTOM SUPPLY OF RF VALVE; IF LH CYL IS SMALLER, TIE THIS TO RC OF THE STEERING BLOCK

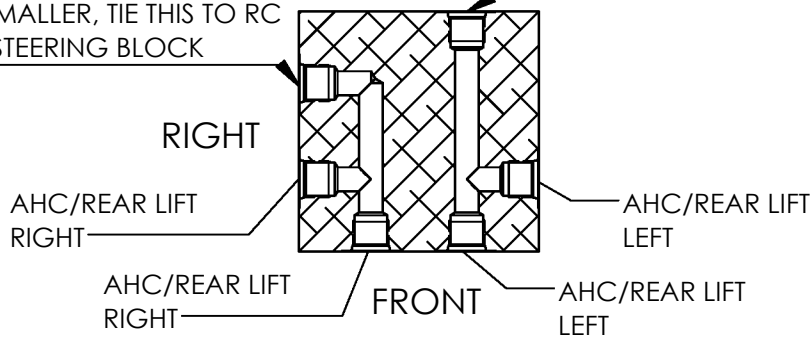

SECTION B-B

\*BALL VALVE IS USED WITH RF RETURN WHEN FRAME MNT RF AND SCALPERS ARE USED\*

IF CENTERING STEERING  
USE INSIDE HOLES

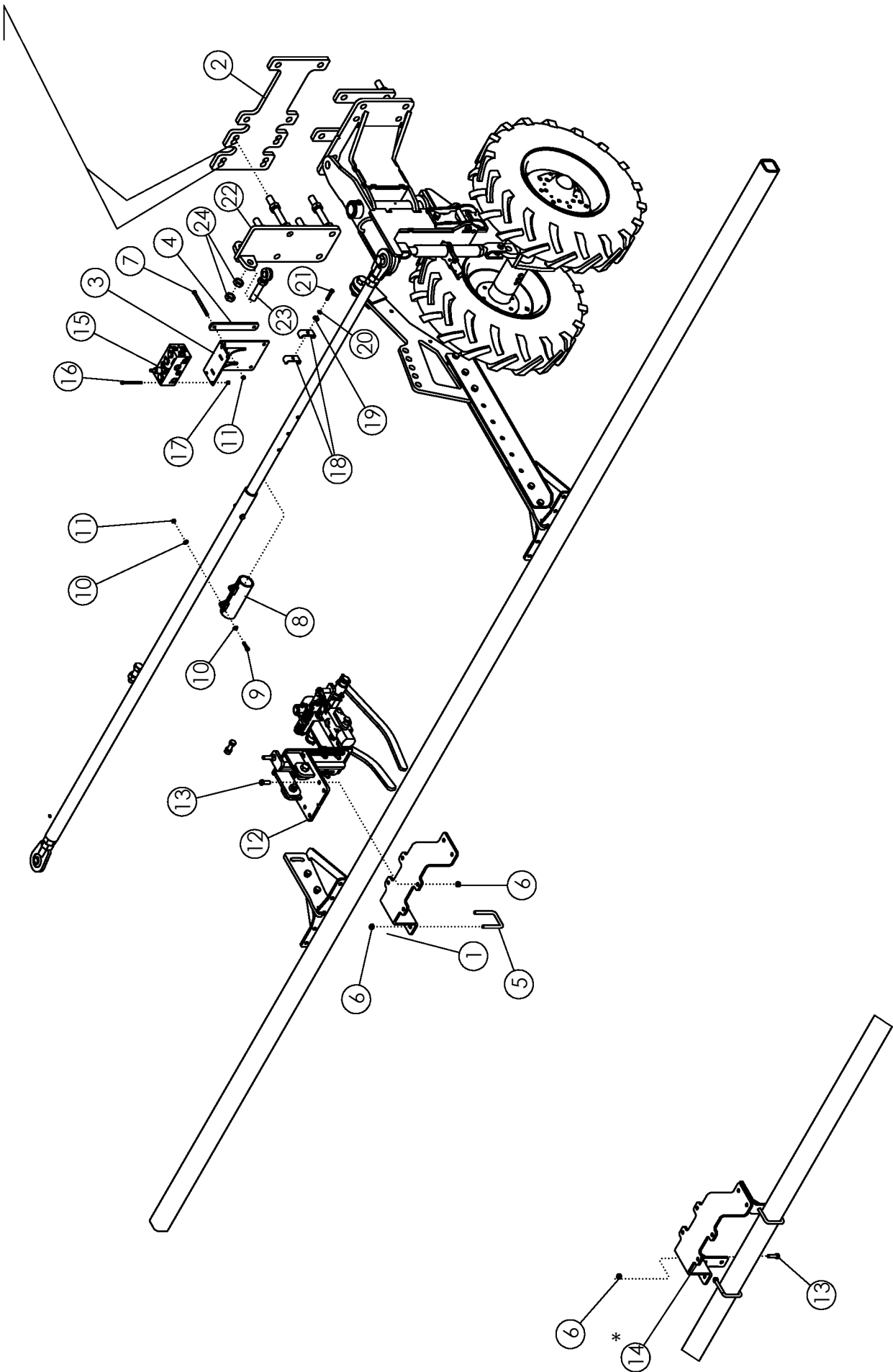

NON-AMITY SCALPER MOUNTING

<b>ROW FINDER - SCALPER MOUNT 6R/8R</b>			
<b>ITEM</b>	<b>PART NO.</b>	<b>DESCRIPTION</b>	<b>QTY</b>
1	70021	WLDMT-DEF ROW FINDER MOUNT	1
2	307195	PLATE-STEERING DOGBONE UNIVERSAL	1
3	69996	WLDMT-DEF VALVE MNT	1
4	64288	PLATE-BRACKET BACKING	2
5	69954	U-BOLT: .50 X 4.50 X 3 X 4.50	2
6	1027461	NUT-TOPLOCK: .50 NC GR5 ZP	8 OR 12*
7	64289	BOLT-HEX: .38 X 5.50 NC GR5 ZP	4
8	69557	WLDMT-TIE ROD CLAMP	1
9	1011602	BOLT-HEX: .38 X 1.50 NC GR5 ZP	2
10	1014608	WASHER-FLT: SAE .38 ZP	4
11	1016999	NUT-TOPLOCK: .38 NC GR5 ZP	6
12	**NOTE**	HYDRAULIC ROWFINDER	1
13	1011608	BOLT-HEX: .50 X 1.75 NC GR 5 ZP	4 OR 8*
14	69454*	WLDMT-RF MOUNT EXTENSION	2
15	69999	VALVE-DEF RF RETURN	1
16	1030778	BOLT-HEX: .31 X 4.00 NC GR5 ZP	2
17	1030700	NUT-TOPLOCK: .31 NC GR5 ZP	2
18	50714	CLAMP .50" ZP	10
19	1014608	WASHER-FLAT: SAE .38 XP	5
20	1011586	WASHER-LOCK: .38 ZP	5
21	1013239	BOLT-HEX: .38 X 3.00 NC GR5 ZP	4
22	306732	WLDMT-CYLINDER BRACKET ADJ	1
23	62081	BOLT-EYEBOLT 1" X 6" GR 8	1
24	1026880	NUT-HEX JAM: 1.00 NC GR2 ZP	3

\* ITEM 14 AND HARDWARE USED ONLY WITH NON AMITY  
SCALPER BASKETS

**\*\*NOTE\*\***

- ROWFINDER NEEDS TO BE OPEN CENTER (PLUG REMOVED)
- PLACE ROWFINDER ON THE FIRST ROW LEFT OF CENTER
- FOR PARTS, REFERENCE ROWFINDER MANUAL PAGE (M4770)

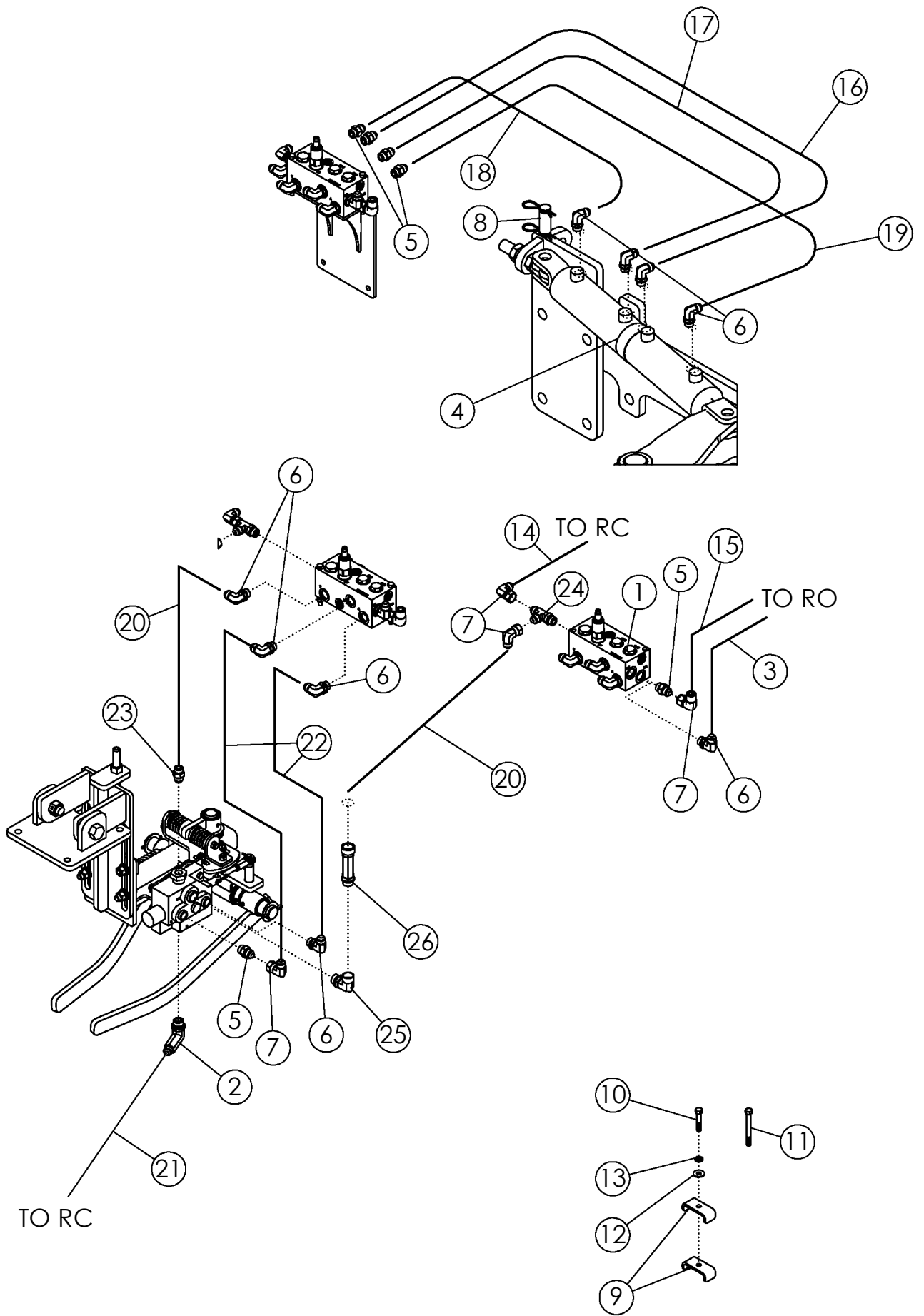

## SCALPER MOUNTED ROW FINDER HYDRAULICS

ITEM	PART NO.	DESCRIPTION	QTY
1	69999	VALVE-DEF ROWFINDER RETURN	1
2	306712	FTG-ELBOW: 10MB-8MJ-90L	1
3	69571	HOSE: .50 X 258 8MB-8FJX90	1
	305676	HOSE: .50 X 027 8FJX-8FJX90	
4	69200	CYLINDER-HYD 3 X 4 4PORT 23.5 CLOSED	1
	35293	SEAL KIT 2015 AND NEWER	
5	56226	FTG-ADAPTER: 8MB-8MJ	11
6	58560	FTG-ELBOW: 8MB-8MJ 90	9
7	57668	FTG-ELBOW: 8MJ-8FJX 90	4
8	69167	PIN-CYLINDER W/CLIPS 1.00 X 2.25	2
9	50714	CLAMP .50" ZP	10
10	1011603	BOLT-HEX: .38 X 1.75 NC GR5 ZP	1
11	1013239	BOLT-HEX: .38 X 3.00 NC GR5 ZP	4
12	1014608	WASHER-FLAT: SAE .38 ZP	5
13	1011586	WASHER-LOCK: .38 ZP	5
14	69570	HOSE: .50 X 252 8FJX-8MB	1
	305675	HOSE: .50 X 017 8FJX-8FJX	
15	69572	HOSE: .50 X 258 8MB-8FJX90L	1
	305677	HOSE: .50 X 027 8FJX-8FJX 90L	
16	305043	HOSE: .50 X 086 X 8FJX-8FJX90 (6R/8R)	1
	69564	HOSE: .50 X 108 8FJX-8FJX90 (9R/12R)	
17	305044	HOSE: .50 X 086 X 8FJX-8FJX90L (6R/8R)	1
	69565	HOSE: .50 X 108 8FJX-8FJX90L (9R/12R)	
18	305045	HOSE: .50 X 092 X 8FJX-8FJX90L (6R/8R)	1
	69566	HOSE: .50 X 114 8FJX-8FJX90L (9R/12R)	
19	305046	HOSE: .50 X 080 X 8FJX-8FJX90 (6R/8R)	1
	69567	HOSE: .50 X 102 8FJX-8FJX90 (9R/12R)	
20	69568	HOSE: .50 X 090 8FJX-8FJX	2
21	69569	HOSE: .50 X 336 8MB-8FJX90	1
	305683	HOSE: .50 X 096 8FJX-8FJX90	
22	305578	HOSE: .50 X 093 X 8FJX-8FJX	2
23	306856	FTG-ADAPTER: 8MB-8MJ W/ .063" ORIFICE	1
24	63016	FTG-TEE: 8MB-8MJ-8MJ	1
25	306711	FTG-ELBOW: 10MB-10FB-90	1
26	301016	VALVE-CHECK: 10MB-10FB 5000 PSI	1
27	58195	FTG-ADAPTER: 10MB-8MJ	1

IF CENTERING STEERING  
USE INSIDE HOLES

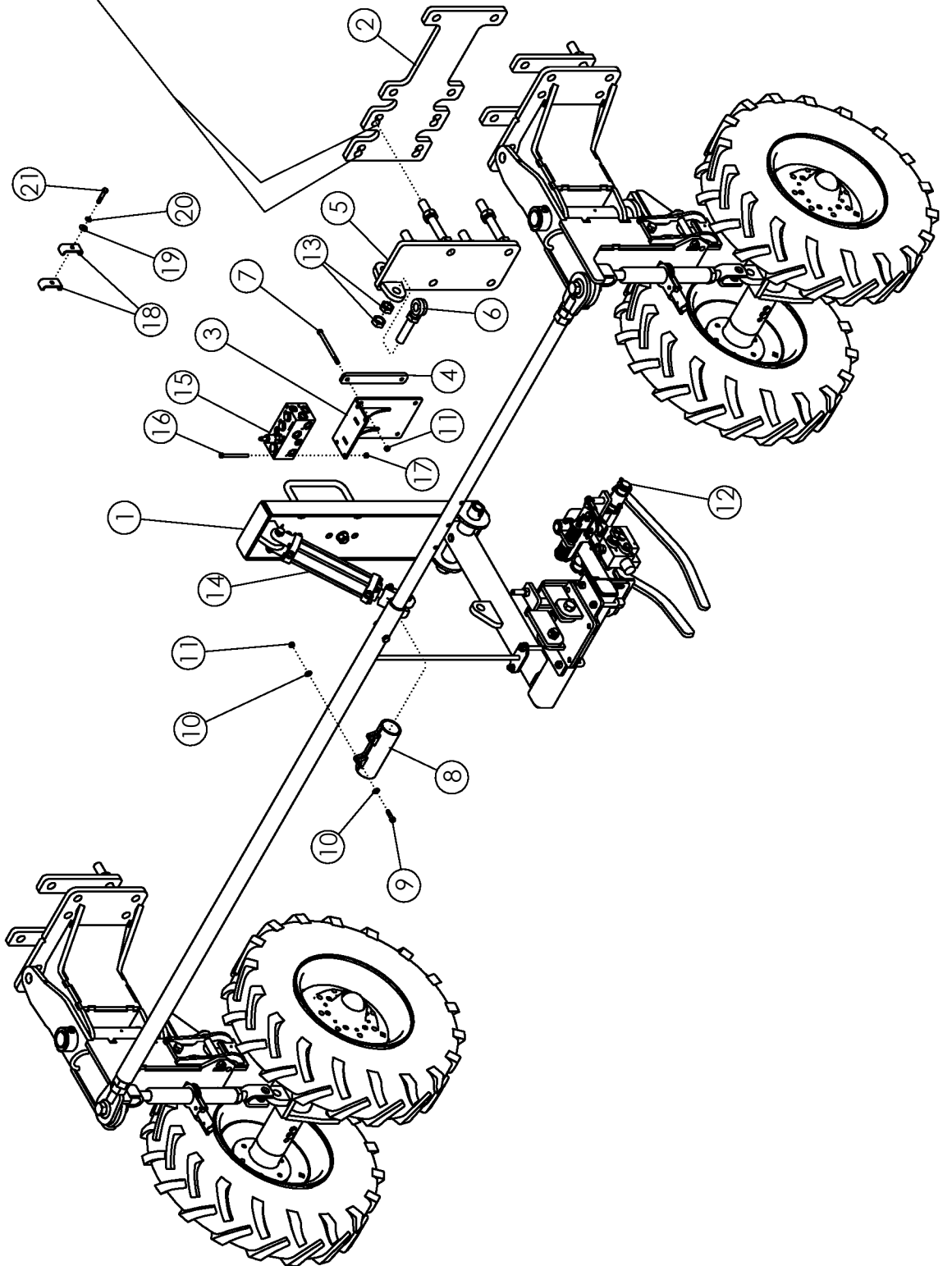

## ROW FINDER - FRAME MOUNTED

ITEM	PART NO.	DESCRIPTION	QTY
1	305055	ASSY-DEF ROW FINDER MOUNT	1
2	307195	PLATE-STEERING DOGBONE UNIVERSAL	1
3	69996	WLDMT-DEF VALVE MNT	1
4	64288	PLATE-BRACKET BACKING	2
5	306732	WLDMT-CYLINDER BRACKET ADJ	1
6	62081	BOLT-EYEBOLT: 1.00 X 6.00 GR8 ZP	1
7	64289	BOLT-HEX: .38 X 5.50 NC GR5 ZP	4
8	69557	WLDMT-TIE ROD CLAMP	1
9	1011602	BOLT-HEX: .38 X 1.50 NC GR5 ZP	2
10	1014608	WASHER-FLT: SAE .38 ZP	4
11	1016999	NUT-TOPLOCK: .38 NC GR5 ZP	6
12	**NOTE**	HYDRAULIC ROW FINDER	1
13	1026880	NUT-JAM: 1.00 NC GR2 ZP	3
14	321936	CYLINDER 2 X 8	1
15	69999	VALVE-DEF RF RETURN	1
16	1030778	BOLT-HEX: .31 X 4.00 NC GR5 ZP	2
17	1030700	NUT-TOPLOCK: .31 NC GR5 ZP	2
18	50714	CLAMP .50" ZP	10
19	1014608	WASHER-FLAT: SAE .38 XP	5
20	1011586	WASHER-LOCK: .38 ZP	5
21	1013239	BOLT-HEX: .38 X 3.00 NC GR5 ZP	4

**\*\*NOTE\*\***

- ROWFINDER NEEDS TO BE OPEN CENTER (PLUG REMOVED)
- PLACE ROWFINDER ON THE FIRST ROW RIGHT OF CENTER
- FOR PARTS, REFERENCE ROWFINDER MANUAL PAGE (M4770)

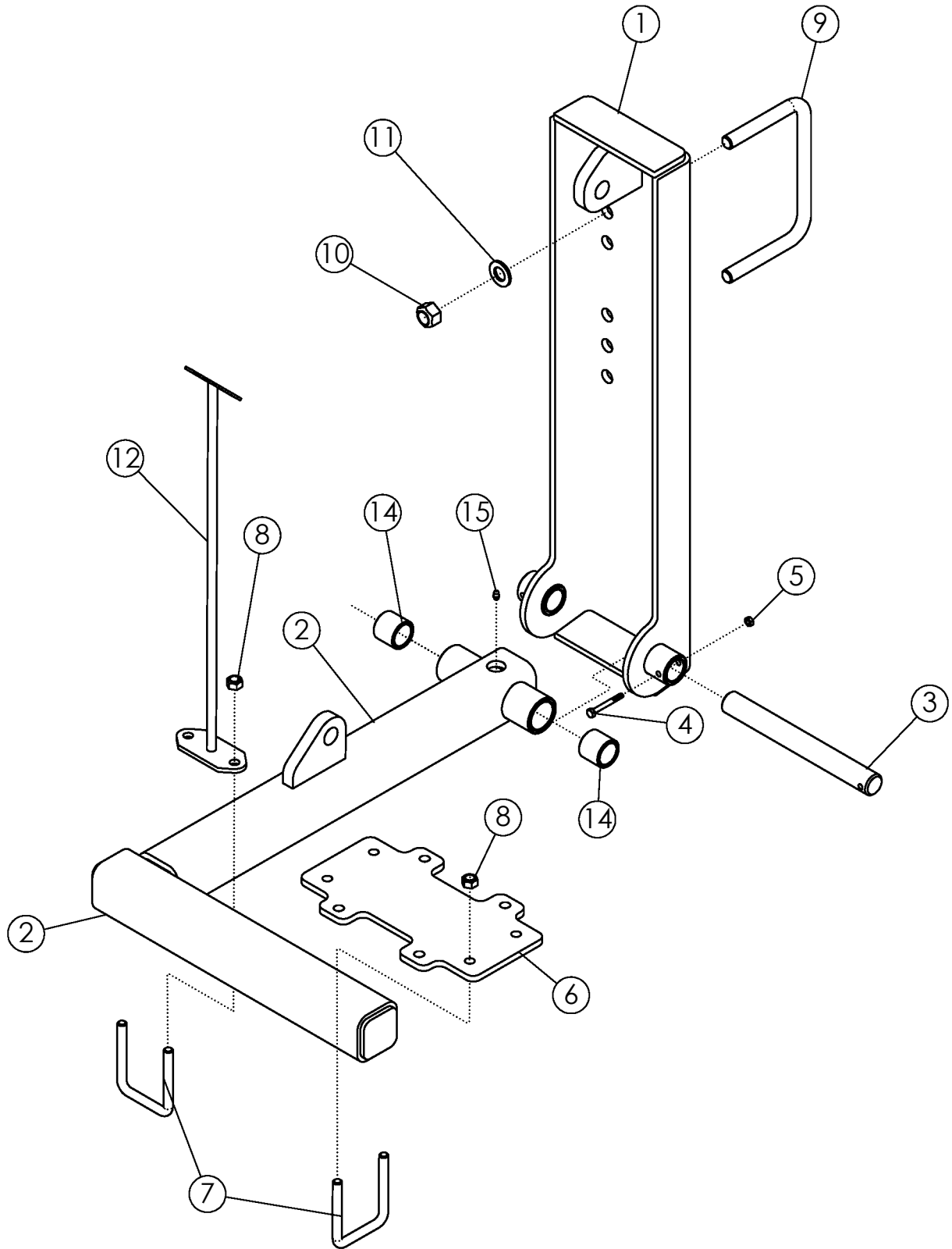



## ASSY - DEF ROW FINDER MOUNT

ITEM	PART NO.	DESCRIPTION	QTY
1	305057	WLDMT-ROW FINDER MOUNT UPPER	1
2	305058	ASSY-ROW FINDER LOWER W/ BUSHINGS	1
3	305053	SHAFT-ROW FINDER	1
4	1013942	BOLT-HEX: .25 X 2.25 NC GR5	1
5	1030946	NUT-TOPLOCK: .25 NC GR5 ZP	1
6	305056	PLATE-DEF FR MOUNT (1 ROW)	1
7	69954	U-BOLT: .500 X 4.00 X 3 X 4.00	3
8	1027461	NUT-TOPLOCK: .50 NC GR5 ZP	6
9	56263	U-BOLT: .75 X 5.5 X 8 X 5.5	2
10	1017000	NUT-TOPLOCK: .75 NC GR5 ZP	4
11	1012634	WASHER-FLAT: SAE .75 ZP	4
12	305410	WLDMT-INDICATOR RF FRAME MOUNT	1
13	65332	DECAL-RED/ORANGE FLUORESCENT (NOT SHOWN)	1
14	56939	BUSHING-OILITE: 1.25 X 1.625 X 1.5L	2
15	1011748	ZERK-GREASE: .25 UNF STRAIGHT	1

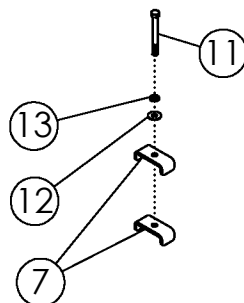
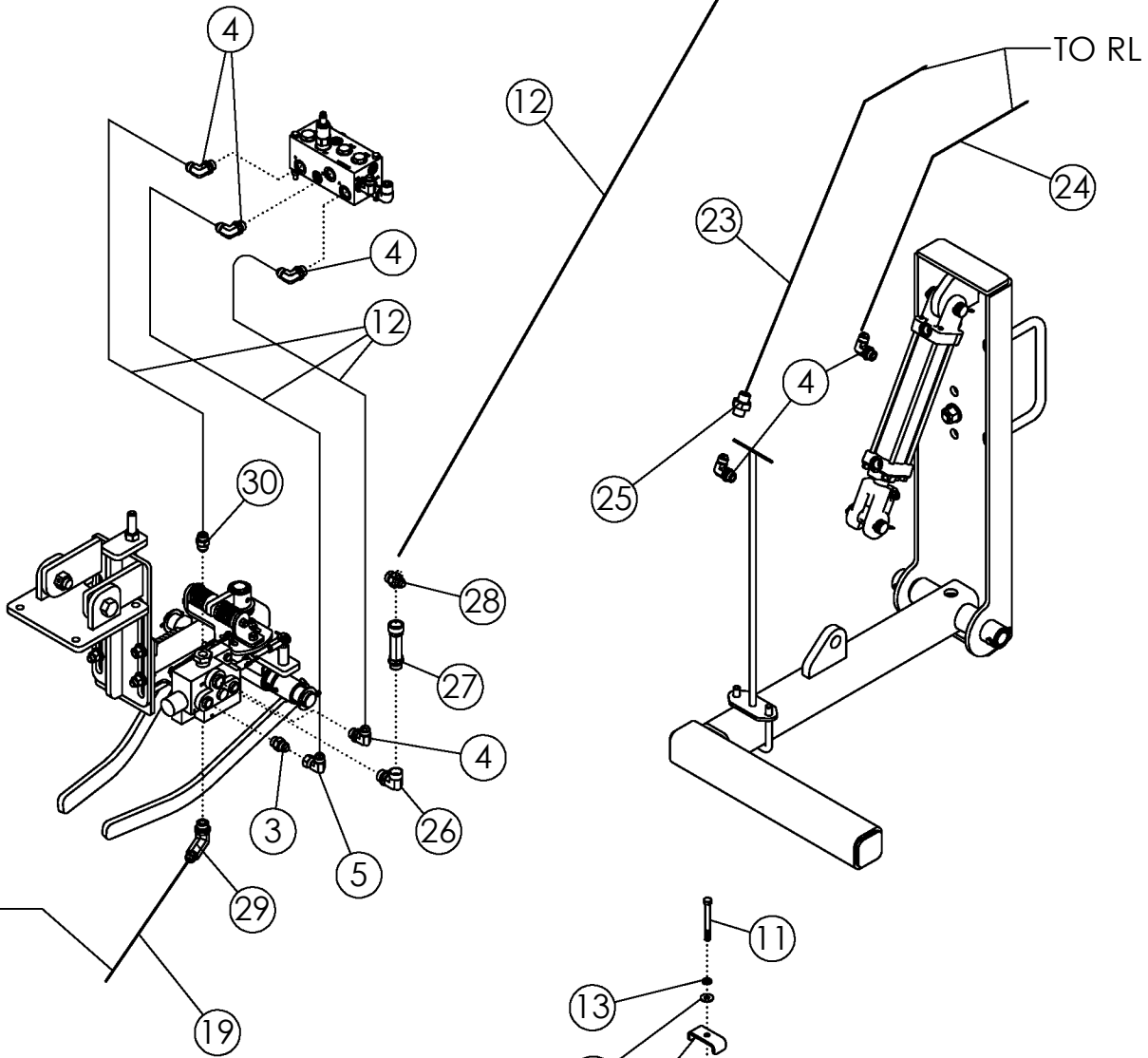
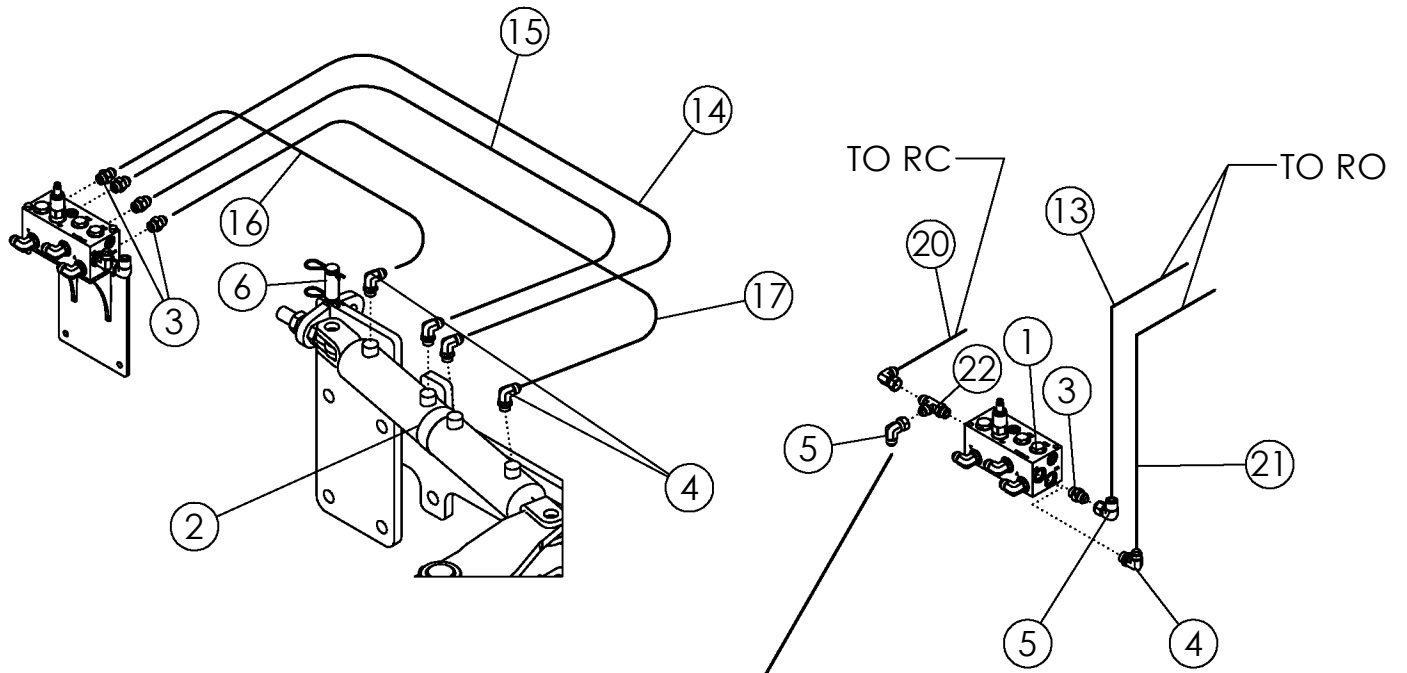

## ROW FINDER HYDRAULICS - FRAME MOUNTED

ITEM	PART NO.	DESCRIPTION	QTY
1	69999	VALVE-DEF ROWFINDER RETURN	1
2	69200	CYLINDER-HYD 3 X 4 4PORT 23.5 CLOSED	1
3	56226	FTG-ADAPTER: 8MB-8MJ	10
4	58560	FTG-ELBOW: 8MB-8MJ 90	11
5	57668	FTG-ELBOW: 8MJ-8FJX 90	4
6	69167	PIN-CYLINDER W/CLIPS 1.00 X 2.25	2
7	50714	CLAMP .50" ZP	10
8	1011603	BOLT-HEX: .38 X 1.75 NC GR5 ZP	1
9	1013239	BOLT-HEX: .38 X 3.00 NC GR5 ZP	4
10	1014608	WASHER-FLAT: SAE .38 ZP	5
11	1011586	WASHER-LOCK: .38 ZP	5
12	300254	HOSE: .50 X 076 X 8FJX-8FJX	4
13	305677	HOSE: .50 X 027 8FJX-8FJX90L	1
	69572	HOSE: .50 X 258 X 8MB-8FJX90L	
14	69654	HOSE: .50 X 108 8FJX-8FJX90 (9R/12R)	1
	305043	HOSE: .50 X 086 8FJX-8FJX90 (6R/8R)	
15	69565	HOSE: .50 X 108 8FJX-8FJX90L (9R/12R)	1
	305044	HOSE: .50 X 086 8FJX-8FJX90L (6R/8R)	
16	69566	HOSE: .50 X 114 8FJX-8FJX90L (9R/12R)	1
	305045	HOSE: .50 X 092 8FJX-8FJX90L (6R/8R)	
17	69567	HOSE: .50 X 102 8FJX-8FJX90 (9R/12R)	1
	305046	HOSE: .50 X 080 8FJX-8FJX90 (6R/8R)	
18	305679	HOSE: .50 X 074 10FJX-8FJX90	1
19	64265	HOSE: .50 X 072 8FJX-8FJX90	1
	69569	HOSE: .50 X 336 X 8MB-8FJX90	
20	305675	HOSE: .50 X 017 8FJX-8FJX	1
	69570	HOSE: .50 X 252 X 8FJX-8MB	
21	305676	HOSE: .50 X 027 8FJX-8FJX90	1
	69571	HOSE: .50 X 258 X 8MB-8FJX90	
22	63016	FTG-TEE: 8MB-8MJ-8MJ	1
23	305441	HOSE: .38 X 040 8FJX-8FJX 90	1
24	305426	HOSE: .38 X 030 8FJX-8FJX 90	1
25	1019844	FTG-RESTRICTOR 8FJ-8MJ .090	1
26	306711	FTG-ELBOW: 10MB-10FB-90	1
27	301016	VALVE-CHECK: 10MB-10FB 5000 PSI	1
28	58195	FTG-ADAPTER: 10MB-8MJ	1
29	306712	FTG-ELBOW: 10MB-8MJ-90L	1
30	306856	FTG-ADAPTER: 8MB-8MJ W/ .063" ORIFICE	1

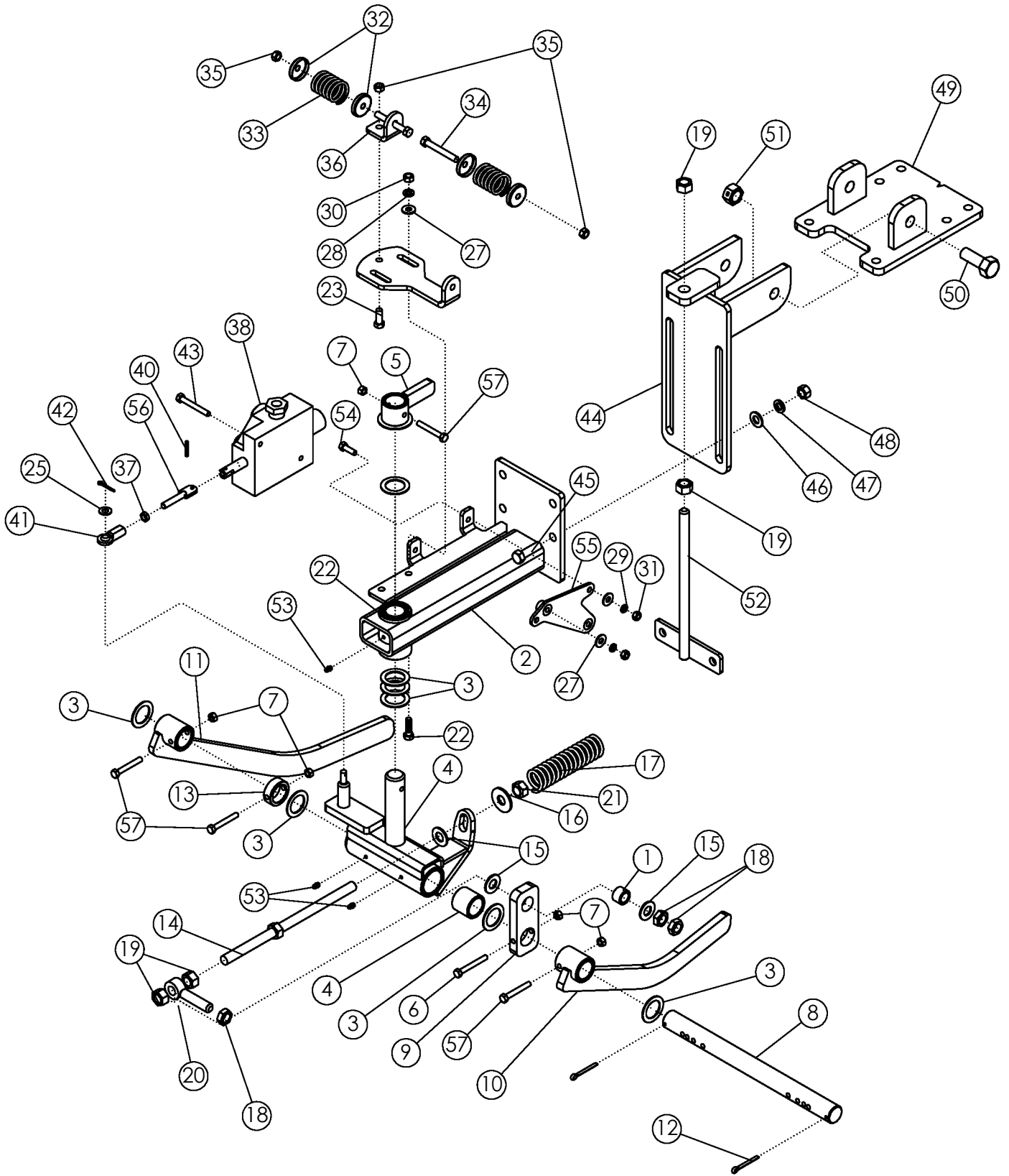

## HYDRAULIC ROW FINDER

ITEM	PART NO.	DESCRIPTION	QTY
1	52567	BUSHING-ZP	1
2	62520	ASSY-MAIN FRAME	1
3	55206	BUSHING-MACH: 1.25 NR 14GA	9
4	51139	ASSY - SWVEL	1
5	51130	WLDMT-FLIPPER	1
6	301748	BOLT-HEX: .31 X 2.50 NC GR8 ZP	1
7	301749	NUT-TOPLOCK: .31 NC GR8 ZP	5
8	51690	SHAFT ZP	1
9	52566	TENSIONER ARM	1
10	51131	SENSOR ARM-L.H.	1
11	52564	SENSOR ARM-R.H.	1
12	1030797	PIN-COTTER: .19 X 1.75 NP	2
13	51137	COLLAR	1
14	52565	ADJUSTMENT BOLT	1
15	1013004	WASHER-FLAT: SAE .63 ZP	3
16	1013024	WASHER-FLAT: .63 ZP	2
17	51692	SPRING: .21 X 1.44 OD X 6.00 15 COILS	1
18	1026259	NUT-JAM: .63 NC GR2 ZP	3
19	1011578	NUT-HEX: .63 NC GR2 ZP	4
20	51691	EYEBOLT: .63 X 3.25 ZP	1
21	1016595	NUT-TOPLOCK: .63 NC GR5 ZP	1
22	1011601	BOLT-HEX: .38 X 1.25 NC GR5 ZP	2
23	1011600	BOLT-HEX: .38 X 1.00 NC GR5 ZP	1
24	51129	PLATE	1
25	1014608	WASHER-FLT: SAE .38 ZP	1
26	1020416	WASHER-FLAT: .25 ZP	2
27	1011583	WASHER-FLAT: .31 ZP	2
28	1011586	WASHER-LOCK: .38 ZP	2
29	1029115	WASHER-LOCK: .31 ZP	2
30	1011576	NUT-HEX: .38 NC GR2 ZP	2
31	1011575	NUT-HEX: .31 NC GR2 ZP	2
32	52582	SPRING CAP	4
33	51689	SPRING	2
34	1019828	BOLT-HEX: .38 X 2.75 NC GR5 ZP	2
35	1016999	NUT-TOPLOCK: .38 NC GR5 ZP	3
36	51128	SPRING PLATE	1
37	1030792	NUT-JAM: .38 NF GR2 ZP	1
38	306698	VALVE-ROWFINDER POWER BEYOND	1
39	62540	PLATE STUD ZP	1
40	64157	PIN-ROLL: .19 X 1.125 ZP	1

CONTINUED

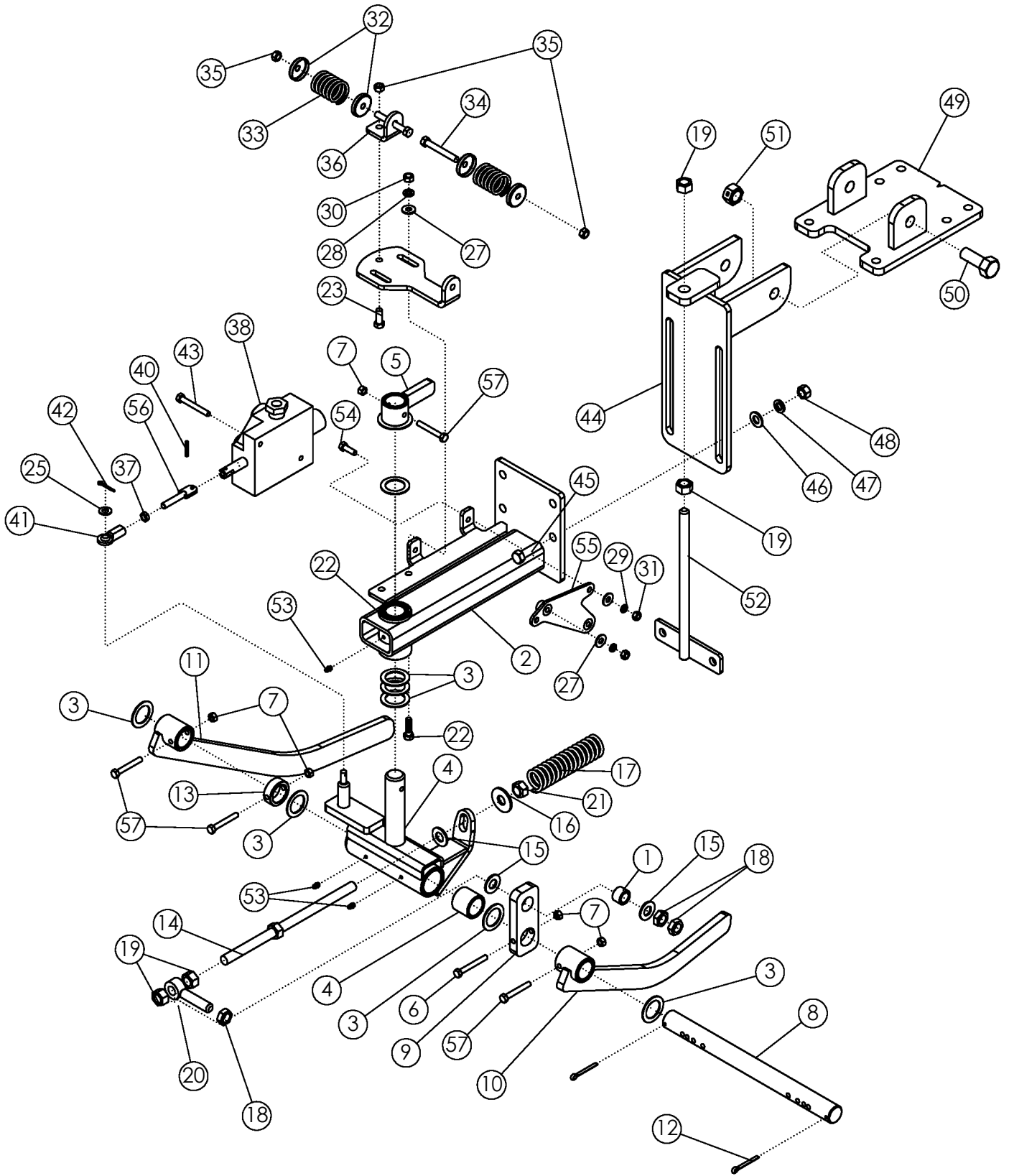

## HYDRAULIC ROW FINDER (CONTINUED)

ITEM	PART NO.	DESCRIPTION	QTY
41	51136	UNIBALL COUPLING	1
42	1029137	PIN-COTTER: .13 X 1.00 ZP	1
43	1027258	BOLT-HEX: .31 X 2.50 NC GR5 ZP	2
44	52181	MOUNTING BRACKET	1
45	1011608	BOLT-HEX: .50 X 1.75 NC GR5 ZP	4
46	1011584	WASHER-FLAT: SAE .50 ZP	4
47	1011581	WASHER-LOCK: .50 ZP	8
48	1011577	NUT-HEX: .50 NC GR2 ZP	8
49	301662	WLDMT-ROW FINDER BRACKET UNIVERSAL	1
50	1012060	BOLT-HEX: .75 X 2.00 NC GR5 ZP	2
51	1013537	NUT-TOPLOCK: .75 NC GR5 ZP	2
52	62882	TIGHTENER BOLT-ZP	1
53	1011748	ZERK - GREASE	3
54	1011598	BOLT-HEX: .31 X 1.00 NC GR5 ZP	2
55	306854	WLDMT-R/F MNT PB	1
56	301750	WLDMT-STUD RF LONG ZP	1
57	301258	BOLT-HEX: .31 X 2.25 NC GR8 ZP	4

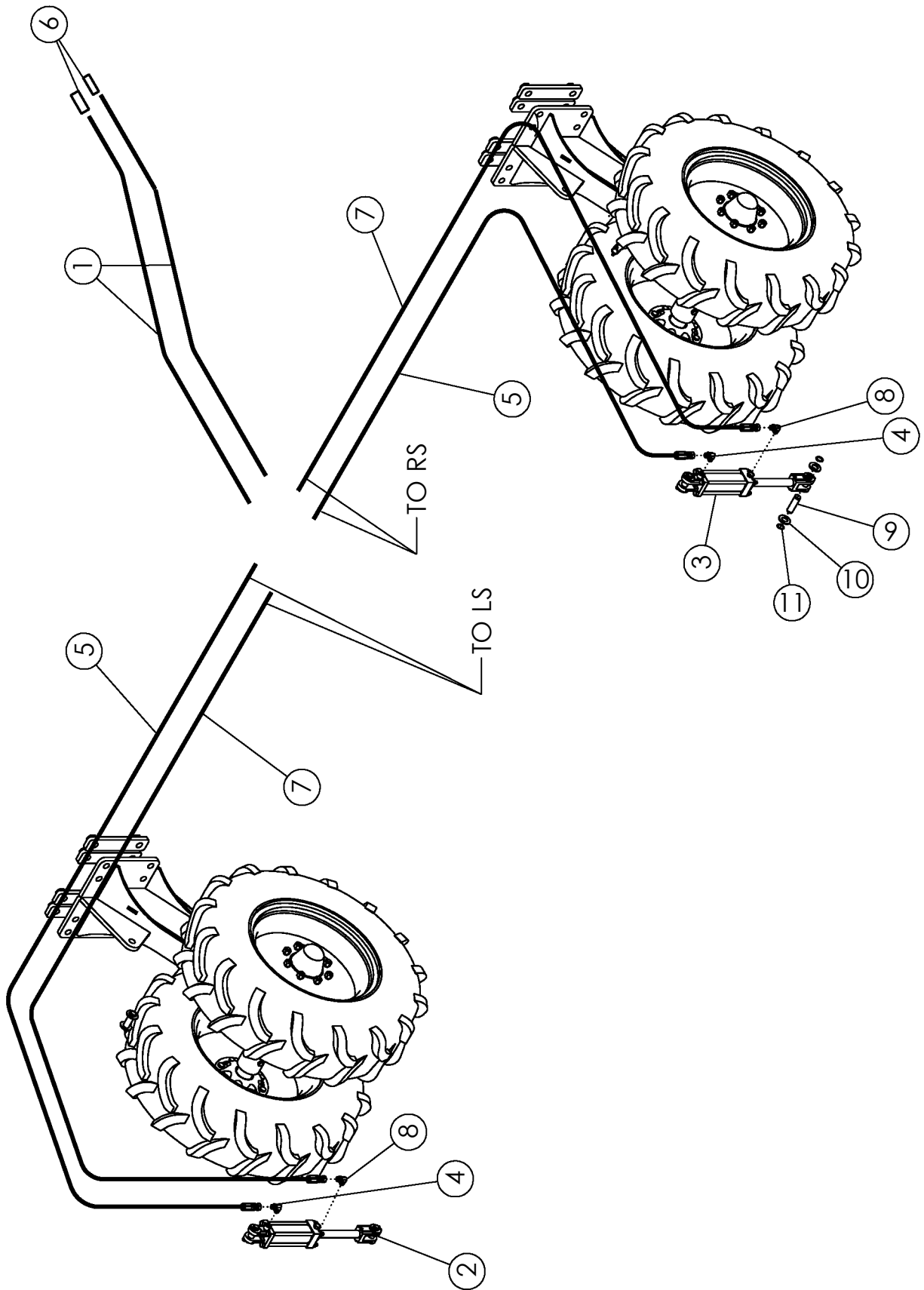



## REAR STRUT HYDRUALICS

ITEM	PART NO.	DESCRIPTION	QTY
1	305684	HOSE: .50 X 215 8FJX-8MB	2
2	63500	CYLINDER-REPHASING 3.25 X 8.00	1
	66083	SEAL KIT FOR 63500	
3	63499	CYLINDER-REPHASING 3.00 X 8.00	1
	301314	SEAL KIT FOR 63499	
4	58560	FTG-ELBOW: 8MB-8MJ-90	2
5	305577	HOSE: .38 X 116 8FJX-8FJX	2
6	36290	PIONEER TIP 8010-15P (#8 ORB)	2
7	305674	HOSE: .38 X 106 8FJX-8FJX	2
8	305402	FTG-ELBOW: 8MB-8MJ-90L	2
9	311191	PIN-CYLINDER 1.00 X 3.45 W/ GROOVE ZP	4
10	1016663	WASHER-FLAT: SAE 1.00 ZP	8
11	36430	RING-RETAINING 1.000 ZP	8

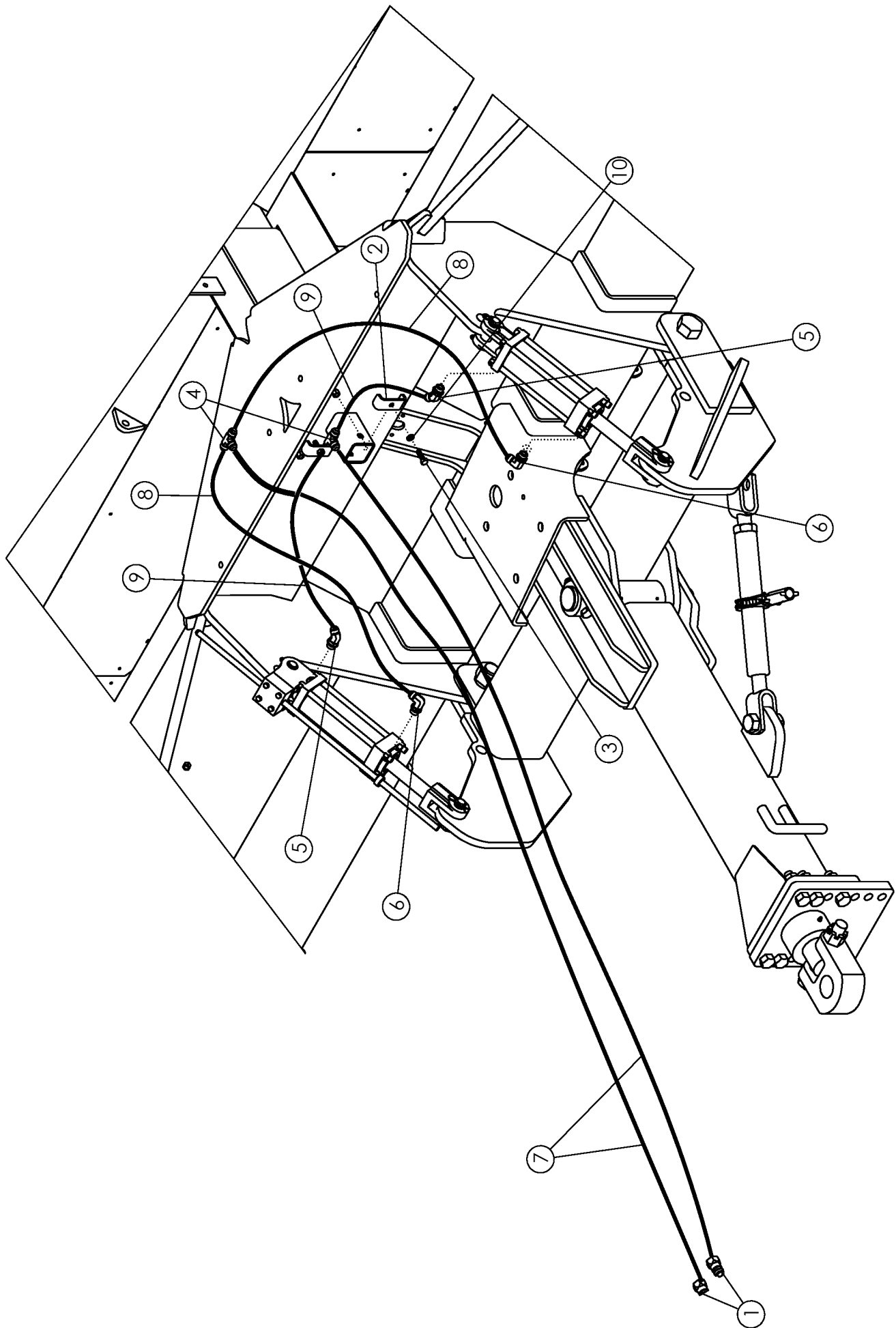

## HITCH HYDRAULICS

ITEM	PART NO.	DESCRIPTION	QTY
1	36290	PIONEER TIP 8010-15 (#8 ORB)	2
2	50714	CLAMP .50 ZP	14
3	1011601	BOLT-HEX: .38 X 1.25 NC GR5 ZP	2
4	57667	FTG-TEE: 8MJ-8MJ-8MJ	2
5	58515	FTG-ELBOW: 8MB-8MJ-45	2
6	58560	FTG-ELBOW: 8MB-8MJ-90	2
7	300053	HOSE: .50 X 108 8MB-8FJX	2
8	57000	HOSE .50 X 034 8FJX-8FJX	2
9	44174	HOSE: .50 X 24 8FJX-8FJX	2
10	1011586	WASHER-LOCK: .38 ZP	2

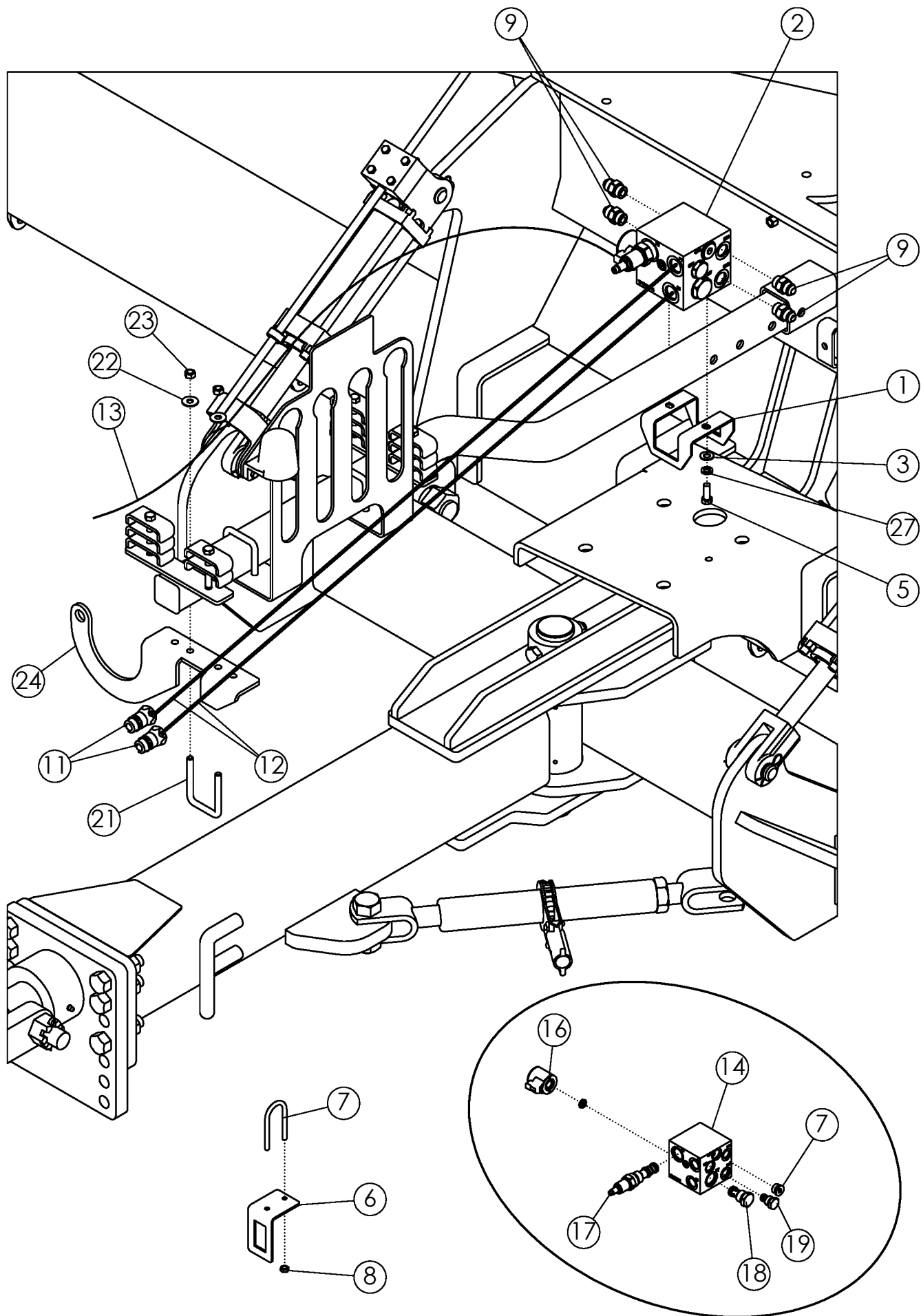

## FLOATING HITCH KIT

ITEM	PART NO.	DESCRIPTION	QTY
1	305430	PLATE-VALVE MOUNT	1
2	305791	FLOATING HITCH VALVE	1
3	1014608	WASHER-FLT: SAE .38 ZP	2
4	1011586	WASHER-LOCK: .38 ZP	2
5	1011600	BOLT-HEX: .38 X 1.00 NC GR5 ZP	2
6	305792	PLATE-SWITCH BRACKET	1
7	340068	U-BOLT: RND .25 X 1.25 X 2.25 ZP	1
8	1030946	NUT-TOPLOCK: .25 NC GR5 ZP	1
9	56226	FTG-ADAPTER: 8MB-8MJ	4
10	305793	ASSY-SWITCH SPST ONE RED LIGHT (NOT SHOWN)	1
11	36290	PIONEER TIP 8010-16P (#10 ORB)	2
12	305431	HOSE: .63 X 108 10MB-10MB	2
13	305440	HARNESS-FLOATING HITCH	1
21	33162	U-BOLT: .375 X 3.00 X 2.00 X 3.00	1
22	1011828	WASHER-FLAT: .38 ZP	2
23	1016999	NUT-TOPLOCK: .38 NC GR5 ZP	2
24	303417	PLATE-PTO STORAGE	1
<b>INCLUDED IN ITEM 2 305791</b>			
14	306714	BLOCK-RAISE/LOWER HITCH	1
15	306715	VALVE-#12 SOLENOID, NC POPPET	1
16	306716	E-COIL-#10, 12 VDC, DEUTSCH DT04-2P, ZENER	1
17	306717	VALVE-#12 PRESSURE REDUCING RELIEVING, PILC	1
18	306718	VALVE-#12 CHECK 5 PSI	1
	306990	KT-SEAL FOR 306718	
19	306719	PLUG-#10 CAVITY	1
	306991	KT-SEAL FOR 306719	
20	306720	PLUG-SAE-10 HOLLOW HEX	1

# TOP VIEW

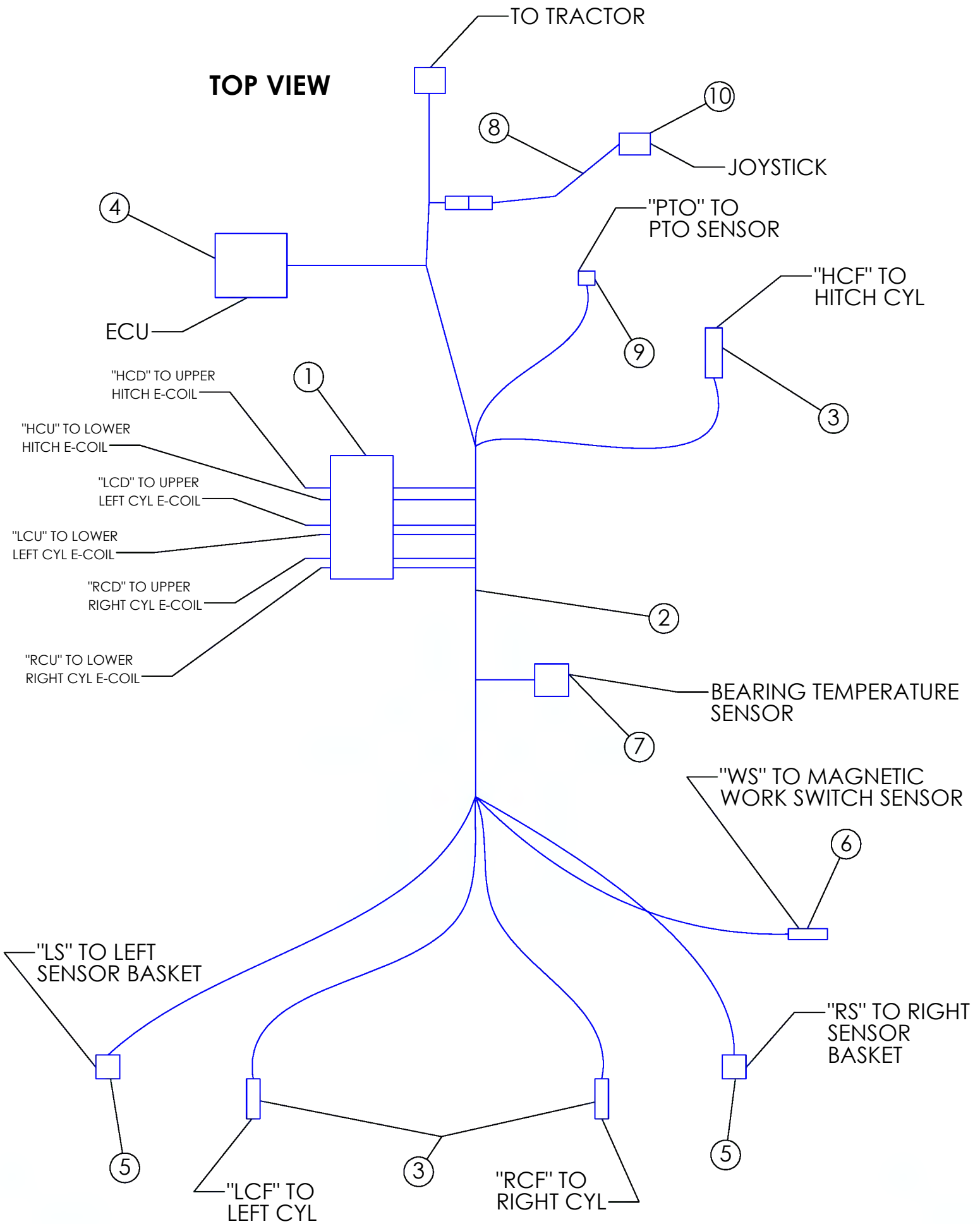

## AHC ISOBUS - ELECTRICAL COMPONENTS

ITEM	PART NO.	DESCRIPTION	QTY
1	305939	VALVE-3 BANK AHC	1
	306996	KT-SEAL FOR 305939	
2	307253	HARNESS-AHC ISOBUS MAIN	1
3	306298	HARNESS-AHC SMART CYL	3
4	307250	ASSY-AHC ISOBUS CONTROLLER	1
5	73492	SENSOR-ROTARY POSITION	2
6	306862	ASSY-MAGNETIC PROXIMITY SENSOR AHC	1
7	307255	SENSOR-AHC TEMPERATURE SENSOR	1
8	303444	HARNESS-ADC ISOBUS JOYSTICK EXT	1
9	301014	SENSOR-PTO ADC	1
10	301151	ASSY-JOYSTICK & ENCLOSURE	1

# TOP VIEW

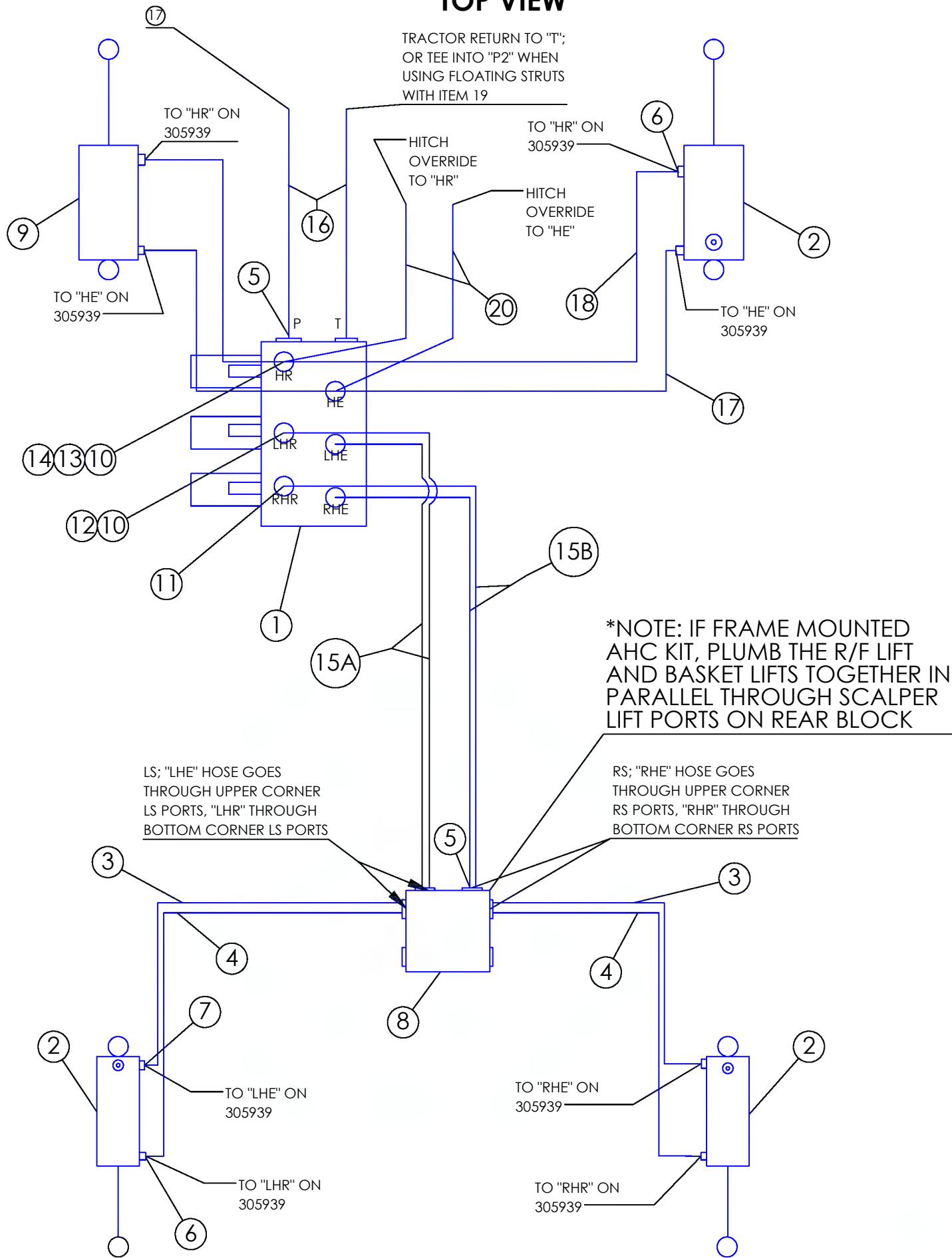



## AHC - HYDRAULIC COMPONENTS

ITEM	PART NO.	DESCRIPTION	QTY
1	305939	VALVE-3 BANK AHC	1
	306878	#10 SPOOL, 4W3P, MOTOR SPOOL	3
	36449	COIL-SDD DOWNPRESSURE	6
	306880	#10 COIL SPACER	3
	306881	VALVE-COUNTER BALANCE 5:1 300	3
	306882	#10 CHECK VALVE 5 PSI	1
	306883	#10 PILOT CHECK 4:1 RATIO 30 PSI	1
	306979	SEAL KIT-CARTRIDGE FOR 305939	1
	306996	KT-SEAL FOR 305939	1
	306893	BOLT-HEX: .31 X 5.50 NC GR5 ZP	2
	1030700	NUT-TOPLOCK: .31 NC GR5 ZP	2
2	305424	CYLINDER-HYD 3 X 8-3000-0" AHC (NO SEAL KIT)	3
3	305674	HOSE: .38 X 106 8FJX-8FJX	2
4	305577	HOSE: .38 X 116 8FJX-8FJX	2
5	56226	FTG-ADAPTER: 8MB-8MJ	10
	58560	FTG-ELBOW: 8MB-8MJ-90 (FOR FLOATING STRUTS)	2
6	58560	FTG-ELBOW: 8MB-8MJ-90	6
7	305402	FTG-ELBOW: 8MB-8MJ-90L	2
8	305960	HYDRAULIC BLOCK AHC	1
9	58891	CYLINDER-HYDRAULIC 4 X 8" 3000	1
10	62024	FTG-ADAPTER: 6MB-8MJ	4
11	1019756	FTG-ELBOW: 6MB-8MJ-90	2
12	57668	FTG-ELBOW: 8MJ-8FJX-90	2
13	63015	FTG-TEE: 8MJ-8FJX-8MJ	2
14	66603	FTG-TEE: 8MJ-8MJ-8FJX	2
15A	36009	HOSE: .50 X 120" 8FJX-8FJX	2
15B	66597	HOSE: .50 X 114" 8FJX-8FJX	2
16	66609	HOSE: .50 X 96" 8MB-8FJX	2
	300034	HOSE: .50 X 84" 8MB-8FJX (FOR FLOATING STRUTS)	2
17	66605	HOSE: .50 X 32" 8FJX-8FJX	2
18	301105	HOSE: .50 X 42" 8FJX-8FJX	2

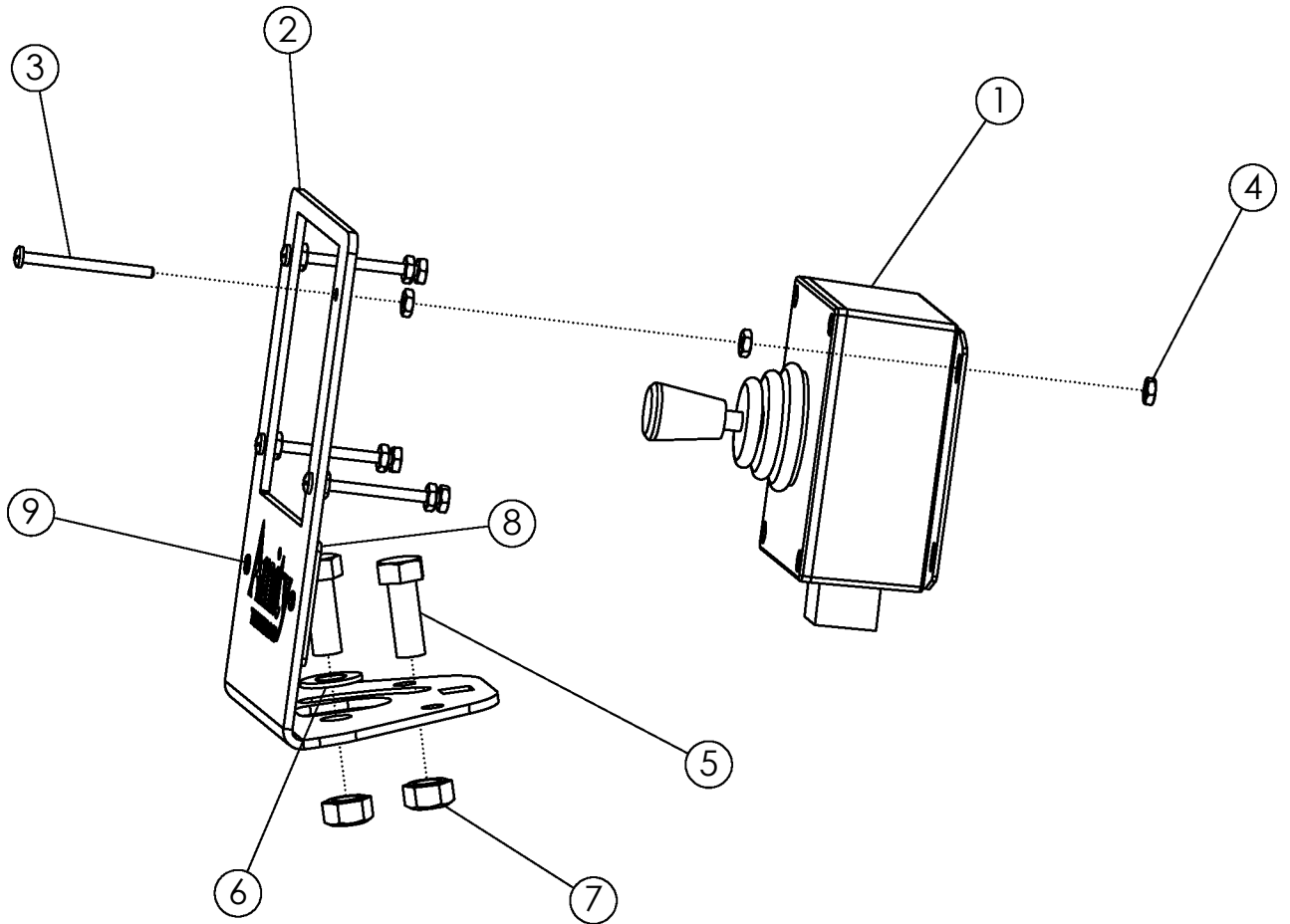

## KT- JOYSTICK WITH MOUNT #303448

ITEM	PART NO.	DESCRIPTION	QTY
1	301151	ASSY-JOYSTICK & ENCLOSURE	1
2	303451	PLATE-JOYSTICK MOUNT	1
3	1019992	SCREWP-H: #6 X 1.75 NC GR5 ZP	4
4	1040448	#6 NUT	12
5	1011600	BOLT-HEX: .38 X 1.00 NC GR5 ZP	2
6	1014608	WASHER-FLAT: SAE .38 ZP	1
7	1016999	NUT-TOPLOCK: .38 NC GR5 ZP	2
8	311514	PLATE-JOYSTICK LOGO	1
9	59882	RIVET-POP: .13 X .31 ZP	2

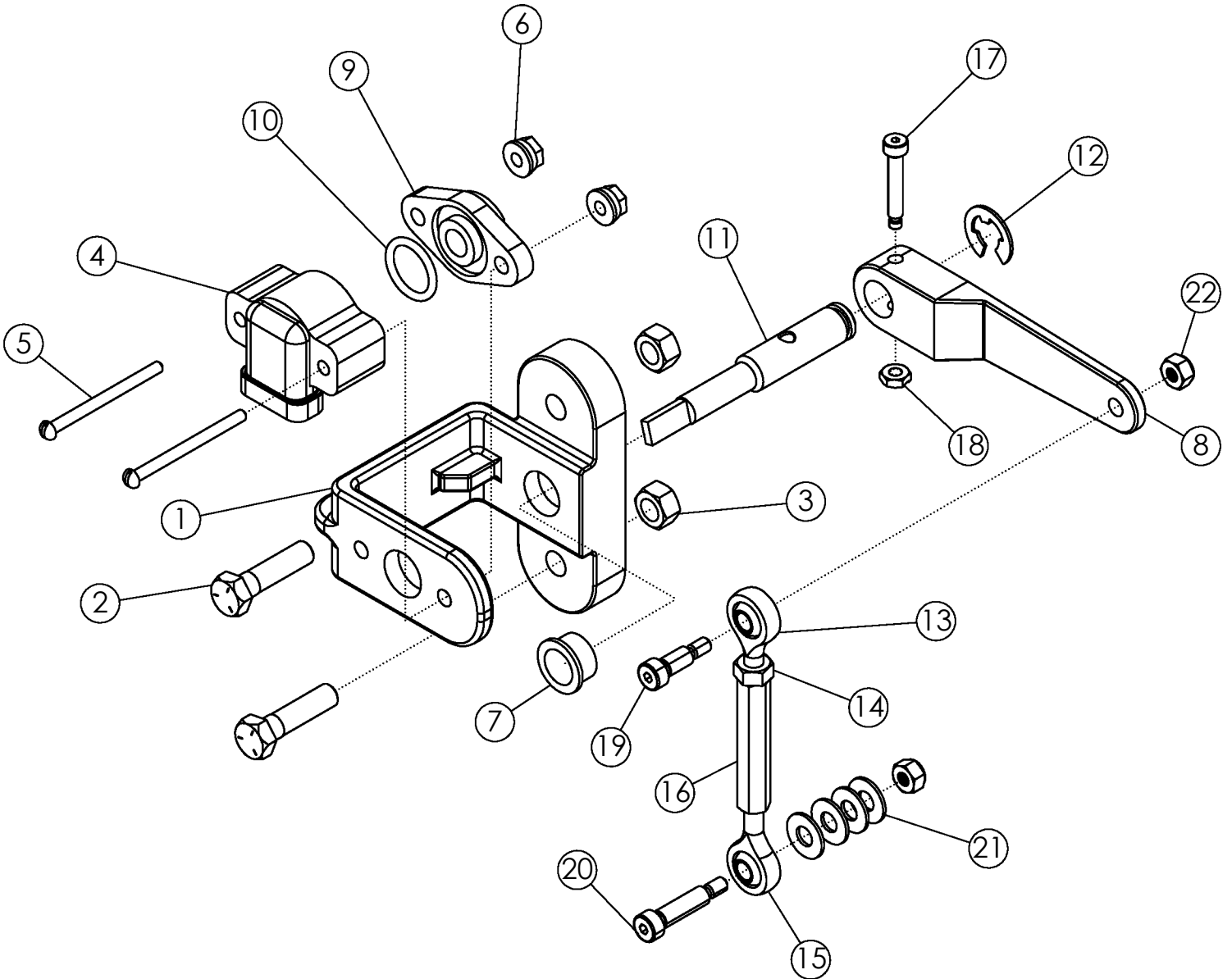

## KT-AHC BASKET SENSOR ASSY (307319)

ITEM	PART NO.	DESCRIPTION	QTY
1	306821	SENSOR BRACKET-AHC	1
2	1032277	BOLT-HEX: .31 X 1.25 NC GR5 ZP	2
3	1030700	NUT-TOPLOCK: .31 NC GR5 ZP	2
4	73492	SENSOR-ROTARY POSITION	1
5	306836	SCREW-MACH RND: #10-24 X 2.0"	2
6	1026591	NUT-K-LOCK: #10-24 NC GR2 ZP	2
7	306822	GROMMET-AHC SHAFT	1
8	306823	LEVER-DLS	1
9	306825	SUPPORT - SHAFT AHC	1
10	306826	O-RING	1
11	306827	SHAFT-AHC ZP	1
12	306895	SNAP-RING: FOR 1/2" OD - 0.46 ID X .035"	1
13	306828	BALL JOINT ROD END 1/4"-28 RH	1
14	1011579	NUT-HEX: .25 NF GR2 ZP	1
15	306829	BALL JOINT ROD END 1/4"-28 LH	1
16	306830	TURNBUCKLE 1/4"-28	1
17	306831	BOLT-SHOULDER: 3/16" X 1.0" SHLD LNGTH X #8-32 THRD	1
18	307497	NUT-NYLOCK: #8-32 GR2 ZP THIN	1
19	306832	BOLT-SHOULDER: 1/4" X 1/2" SHLD LNGTH X #10-24 THRD	1
20	306833	BOLT-SHOULDER: 1/4" X 1.0" SHLD LNGTH X #10-24 THRD	1
21	65695	WASHER-FLAT: .25 SS	4
22	67079	NUT-NYLOCK: #10-24 NC GR2 ZP	2

ASSEMBLED VIEW

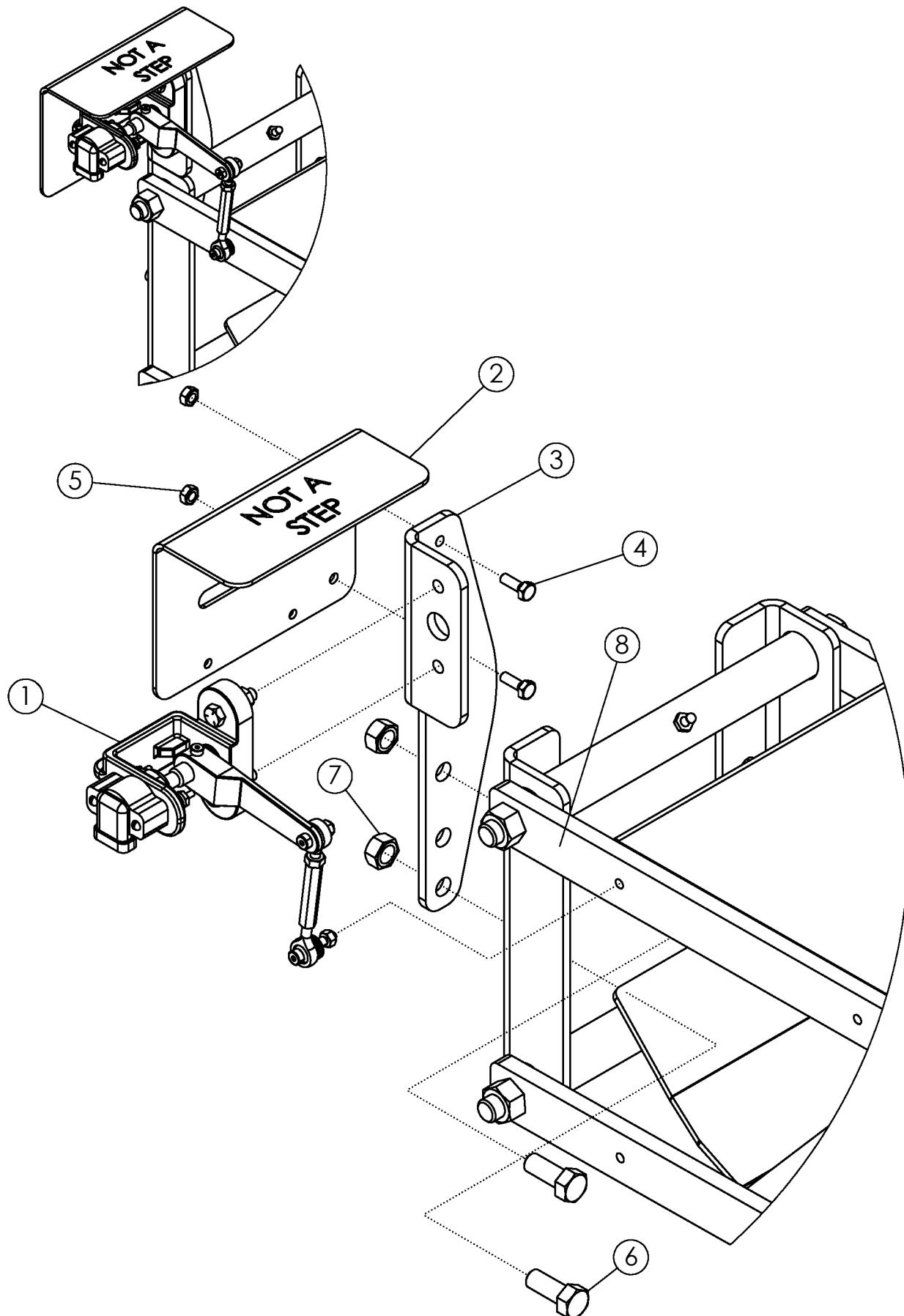

## BASKET SENSOR MOUNT

ITEM	PART NO.	DESCRIPTION	QTY
1	307319	KT-AHC BASKET SENSOR ASSY	1
2	306926	PLATE-AHC SENSOR COVER	1
3	306835	PLATE-AHC SENSOR MOUNT BRACKET	1
4	1011595	BOLT-HEX: .25 X .75 NC CR5 ZP	2
5	1030946	NUT-TOPLOCK: .25 NC GR5 ZP	2
6	1011606	BOLT-HEX: .50 X 1.25 NC GR5 ZP	2
7	1027461	NUT-TOPLOCK: .50 NC GR5 ZP	2
8	306848	BAR-PARALLEL LINK AHC THREADED PC	1

**FIG. 1 - PTO SENSOR MOUNT**



**FIG. 2 - WORKSWITCH MOUNT**

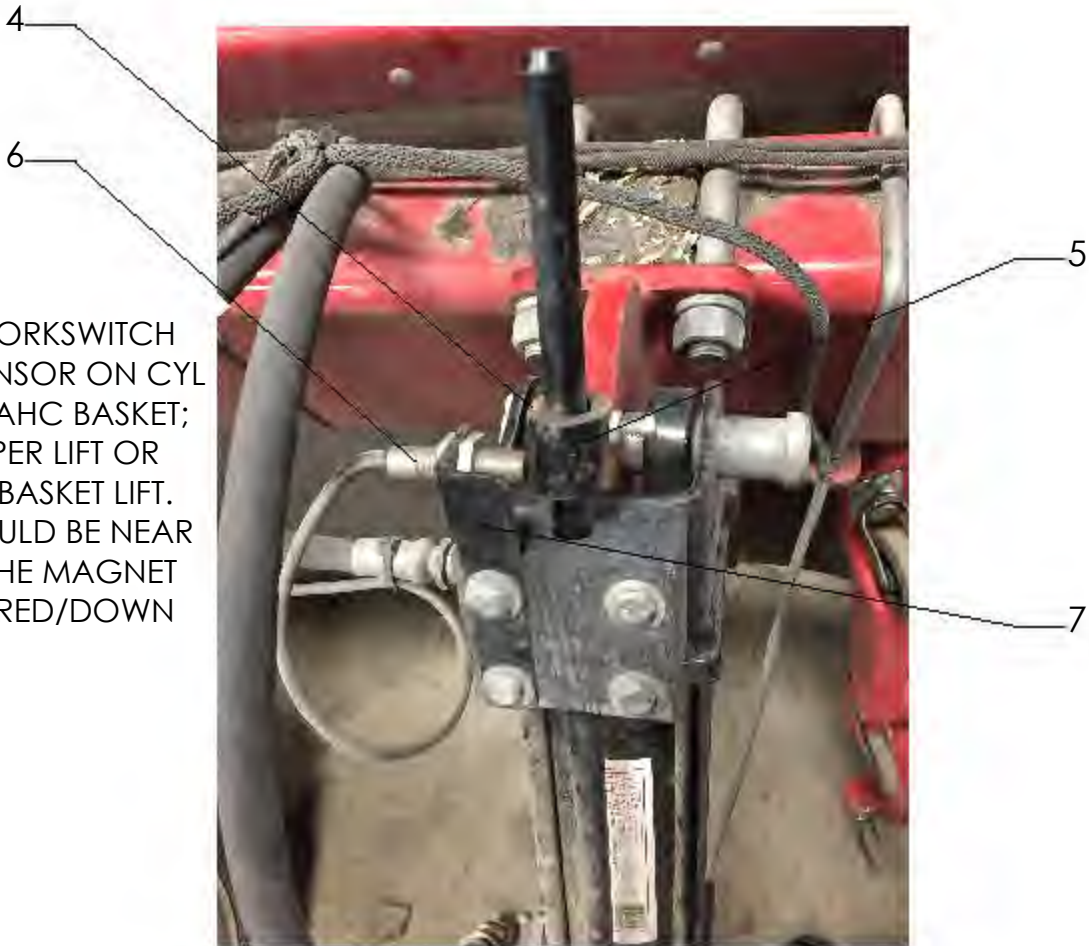

NOTE:  
ASSEMBLE WORKSWITCH  
TO DEPTH SENSOR ON CYL  
THAT RAISES AHC BASKET;  
EITHER SCALPER LIFT OR  
AHC FRAME BASKET LIFT.  
SENSOR SHOULD BE NEAR  
TOUCHING THE MAGNET  
IN THE LOWERED/DOWN  
POSITION



## **PTO SENSOR (FIG. 1)**

<b>ITEM</b>	<b>PART NO.</b>	<b>DESCRIPTION</b>	<b>QTY</b>
1	301014	SENSOR-PTO ADC	1
2	64388	WLDMT-SPLIT COLLAR 1.75"	1
3	305958	PLATE-PTO SENSOR MOUNT	1

## **MAGNETIC WORKSWITCH (FIG.2)**

4	305959	MAGNET-WORK SWITCH AHC	1
5	305595	TUBE-AHC MAGNET HOLDER ZP	1
6	306862	ASSY-MAGNETIC PROXIMITY SENSOR AHC	1
7	306896	PLATE-MAGNETIC SENSOR MNT	1

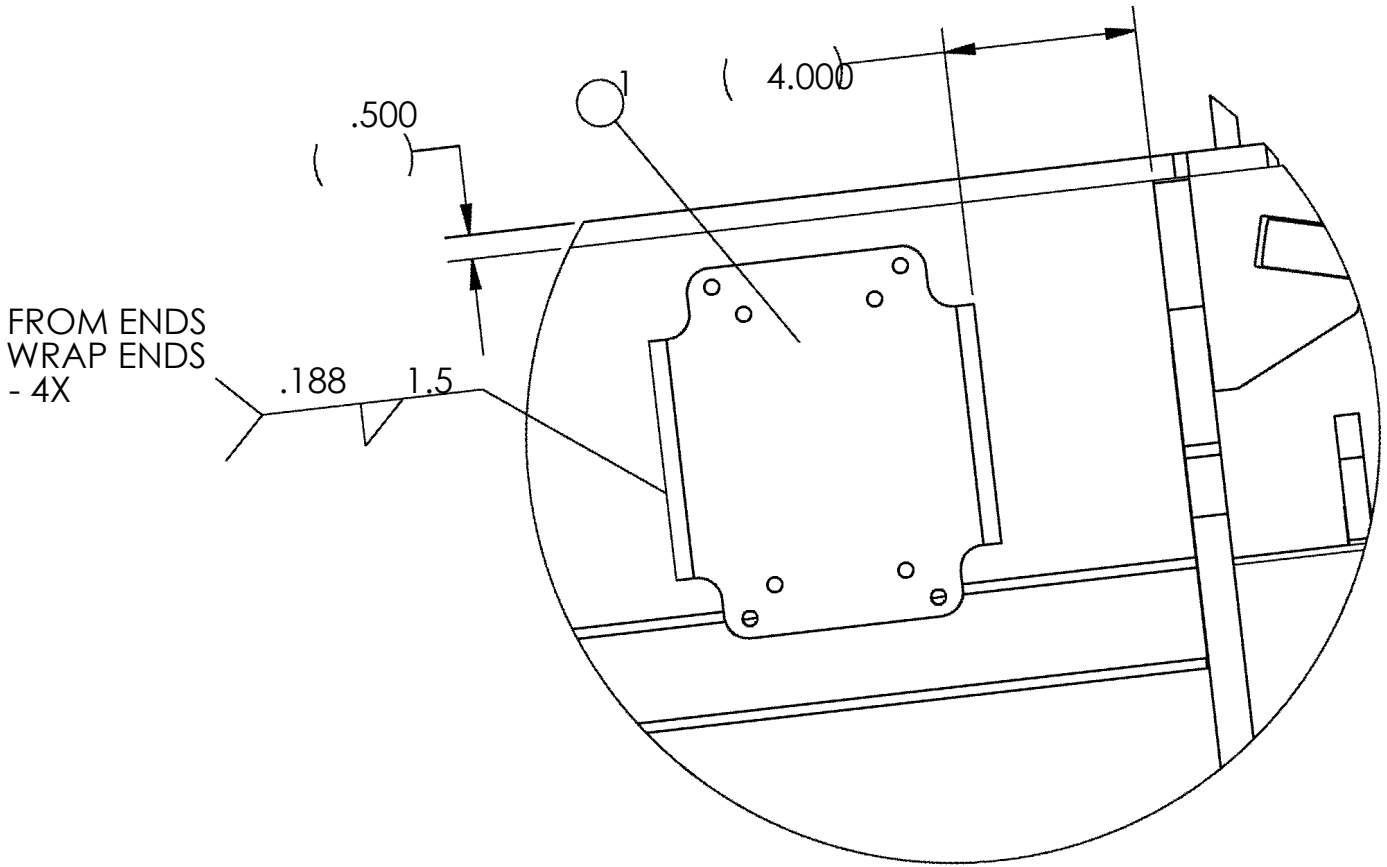
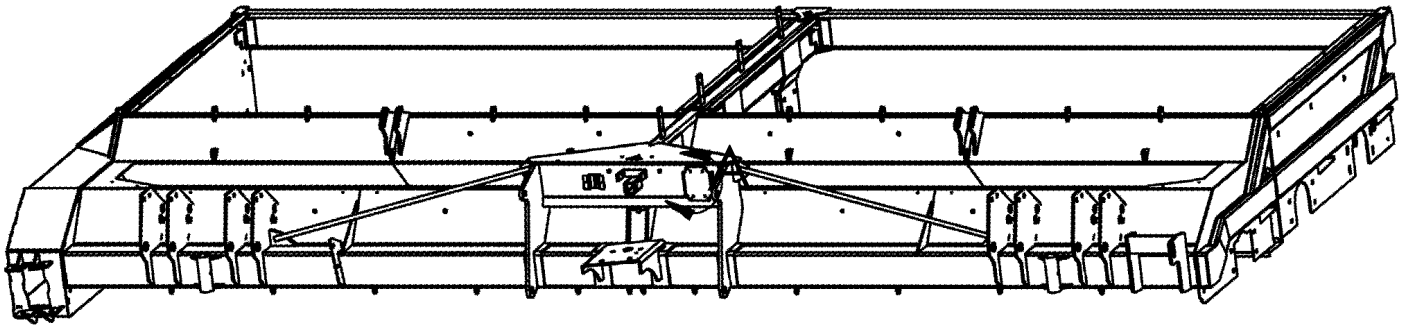

## ECU MOUNT

ITEM	PART NO.	DESCRIPTION	QTY
1	306894	PLATE-ECU MOUNT HOLDER	1

## REFERENCE PICTURES



INTENTIONALLY LEFT BLANK

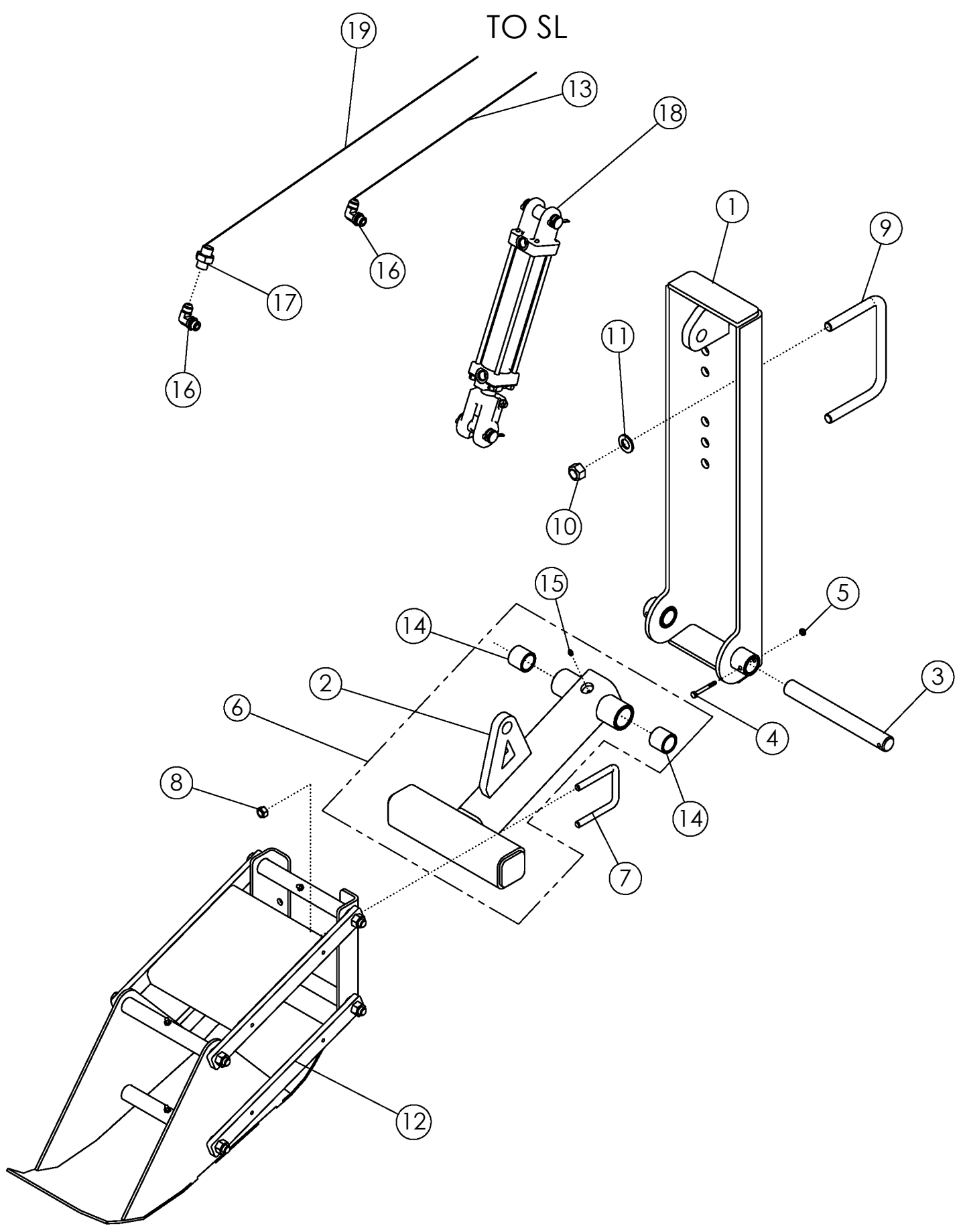

## ASSY - AHC FRAME MOUNT

ITEM	PART NO.	DESCRIPTION	QTY
1	305057	WLDMT-ROW FINDER MOUNT UPPER	1
2	305058-1	WLDMT-ROW FINDER LOWER	1
3	305053	SHAFT-ROW FINDER	1
4	1013942	BOLT-HEX: .25 X 2.25 NC GR5	1
5	1030946	NUT-TOPLOCK: .25 NC GR5 ZP	1
6	305058	ASSY-ROW FINDER LOWER W/BUSHINGS	1
7	69954	U-BOLT: .500 X 4.00 X 3 X 4.00	2
8	1027461	NUT-TOPLOCK: .50 NC GR5 ZP	4
9	56263	U-BOLT: .75 X 5.5 X 8 X 5.5	2
10	1017000	NUT-TOPLOCK: .75 NC GR5 ZP	4
11	1012634	WASHER-FLAT: SAE .75 ZP	4
12	306887	ASSY-AHC NO KNIFE BASKET	1
13	69079	HOSE: .38 X 144 8FJX-8FJX	1
14	56939	BUSHING-OILITE: 1.25 X 1.625 X 1.5L	2
15	1011748	ZERK-GREASE: .25 UNF STRAIGHT	1
16	58560	FTG-ELBOW: 8MB-8MJ-90	2
17	1019844	FITTING-RESTRICTOR (8FJ-8MJ .090)	1
18	58890	CYLINDER-HYDRAULIC 3 X 8" 3000	1
19	69078	HOSE: .38 X 132 8FJX-8FJX	1

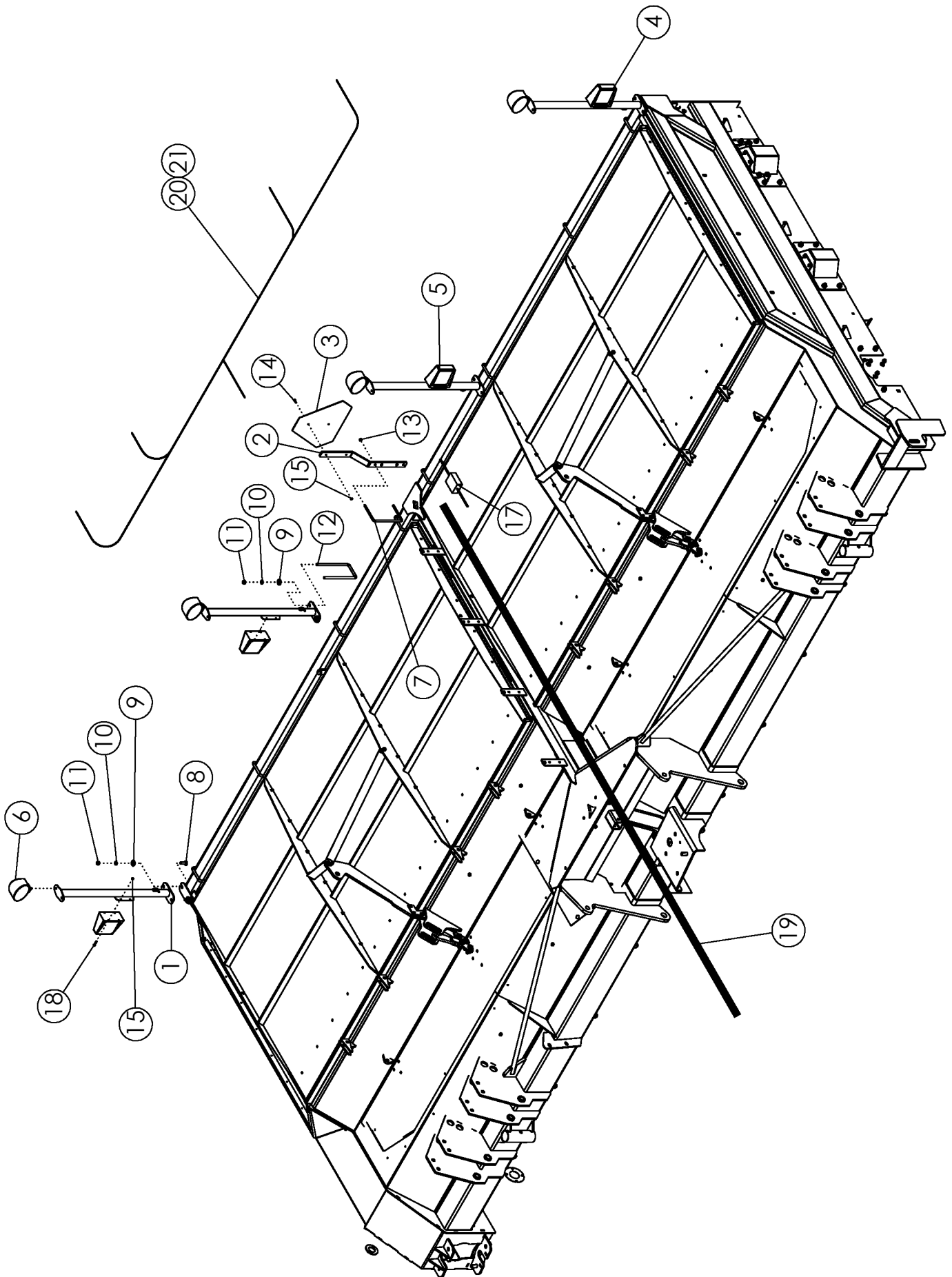



## LIGHT KIT

ITEM	PART NO.	DESCRIPTION	QTY
1	305219	WLDMT-LIGHT MOUNT	4
2	64246	MOUNT-SMV SIGN	1
3	65329	SIGN-SMV ASAE	1
4	305217	LIGHT-YELLOW LAMP SAE	2
5	305218	LIGHT-RED LAMP SAE	2
6	301294	LIGHT-GROTE T26 NEAR FLOOD	4
7	64244	U-BOLT: .375 X 5.125 X 8.063 X 5.125	1
8	1011660	BOLT-CRG: .50 X 1.50 NC GR5 ZP	4
9	1014443	WASHER-FLAT: .50 ZP	8
10	1011581	WASHER-LOCK: .50 ZP	8
11	1011577	NUT-HEX: .50 NC ZP	8
12	63458	U-BOLT: .50 X 9.25 X 4.00 X 9.25 ZP	2
13	1016999	NUT-TOPLOCK: .38 NC GR5 ZP	2
14	1011595	BOLT-HEX: .25 X .75 NC GR5 ZP	2
15	1030946	NUT-TOPLOCK: .25 NC GR5 ZP	18
16	1013122	TIE-NYLON CABLE 50# X 15.50" (NOT SHOWN)	12
17	305216	MODULE-FLASHER HARNESS	1
18	1013940	BOLT-HEX: .25 X 1.25 NC GR5	16
19	305213	HARNESS-DEF LIGHT LEAD	1
20	305214	HARNESS-DEF WORK LIGHT	1
21	305215	HARNESS-DEF LGIHT	1

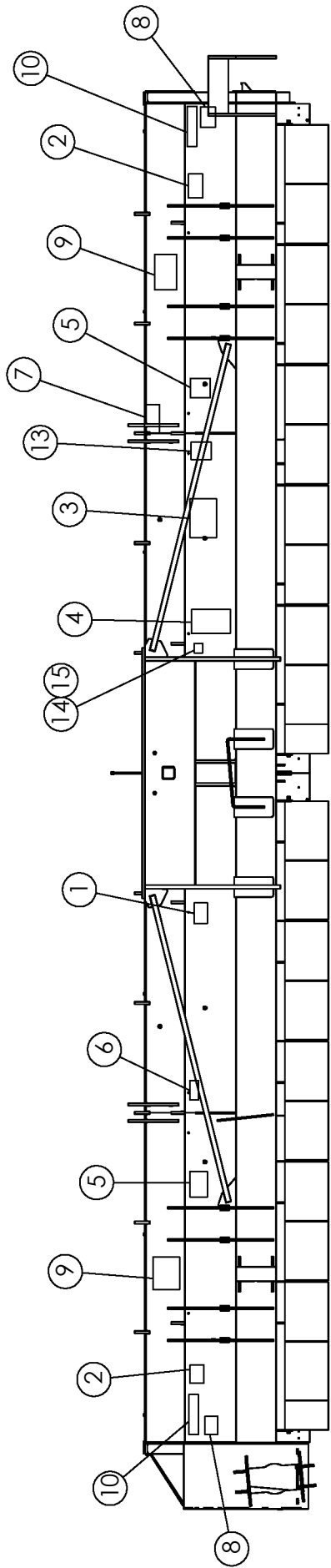

FRONT VIEW

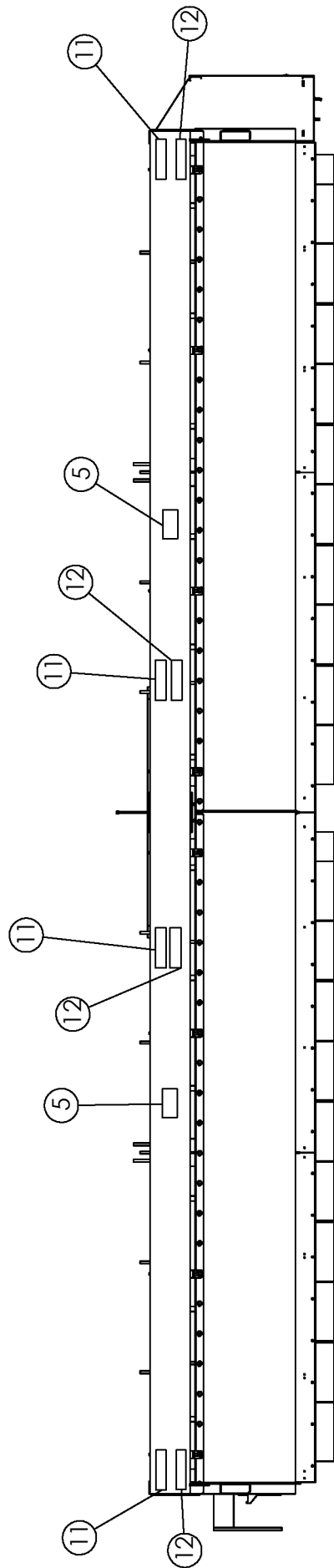

REAR VIEW

## DECALS

ITEM	PART NO.	DESCRIPTION	QTY
1	52341	DECAL-WARNING	1
2	52334	DECAL-WARNING	2
3	52329	DECAL-DANGER	1
4	52339	DECAL-WARNING	1
5	52340	DECAL-DANGER	4
6	52338	DECAL DANGER	1
7	52336	DECAL-CAUTION	4
8	64617	DECAL-DANGER	2
9	63465	DECAL-LOGO	2
10	65331	DECAL-RETROFLECTIVE-YELLOW	2
11	65330	DECAL-RETROFLECTIVE-RED	4
12	65332	DECAL-RED ORANGE FLUORESCENT	2
13	62964	DECAL-WARNING	1
14	1028371	TAG: SERIAL#/MODEL#/YEAR	1
15	59882	RIVET-POP: .13 X .31 ZP	2

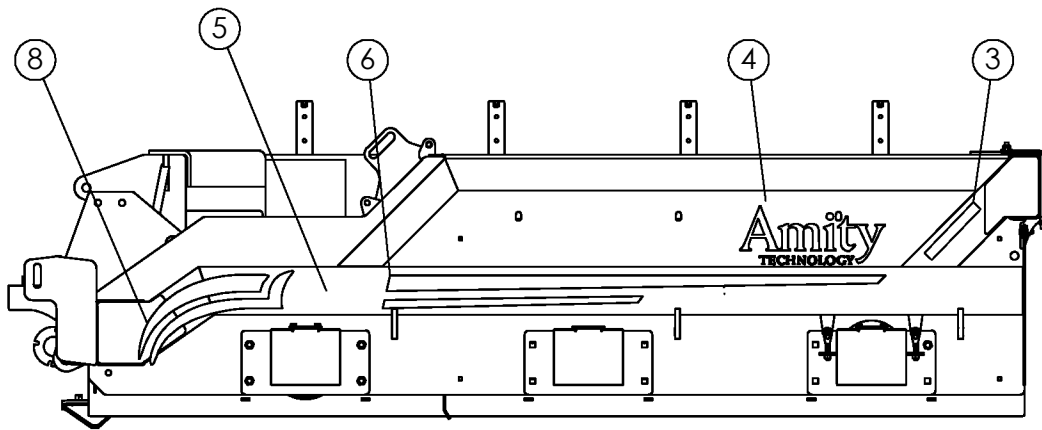
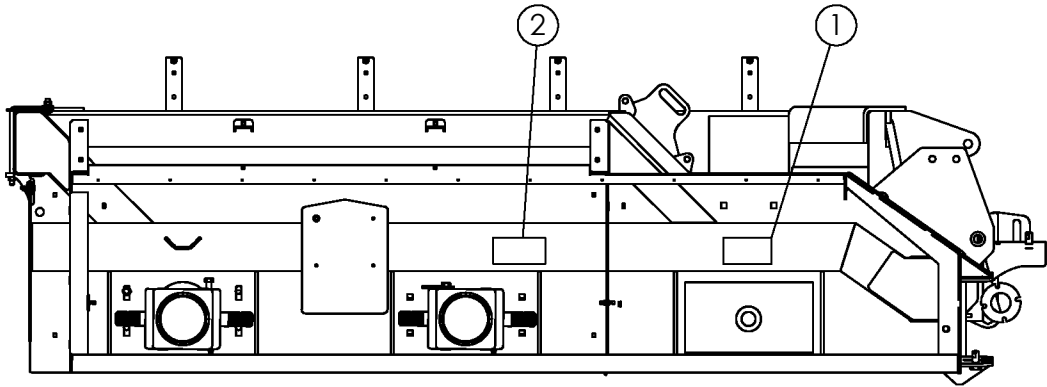
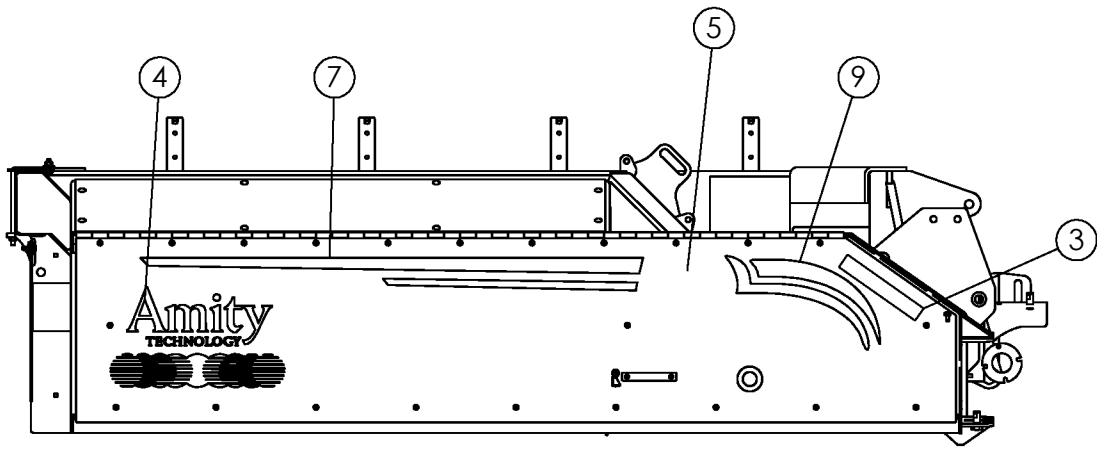

LEFT SIDE

## DECALS

ITEM	PART NO.	DESCRIPTION	QTY
1	52341	DECAL-WARNING SHIELDS	1
2	52329	DECAL-DANGER MOVING PART	1
3	65331	DECAL-YELLOW RETROFLECTIVE	2
4	69399	DECAL-AMITY LOGO 12X24	2
5	305692	DECAL-3750 6X12	2
	305689	DECAL-3550 6X12	
	306118	DECAL-3450 6X12	
6	69406	DECAL-LH STRIPE	1
7	69408	DECAL-RH STRIPE	1
8	69405	DECAL-LH CURVE	1
9	69407	DECAL-RH CURVE	1

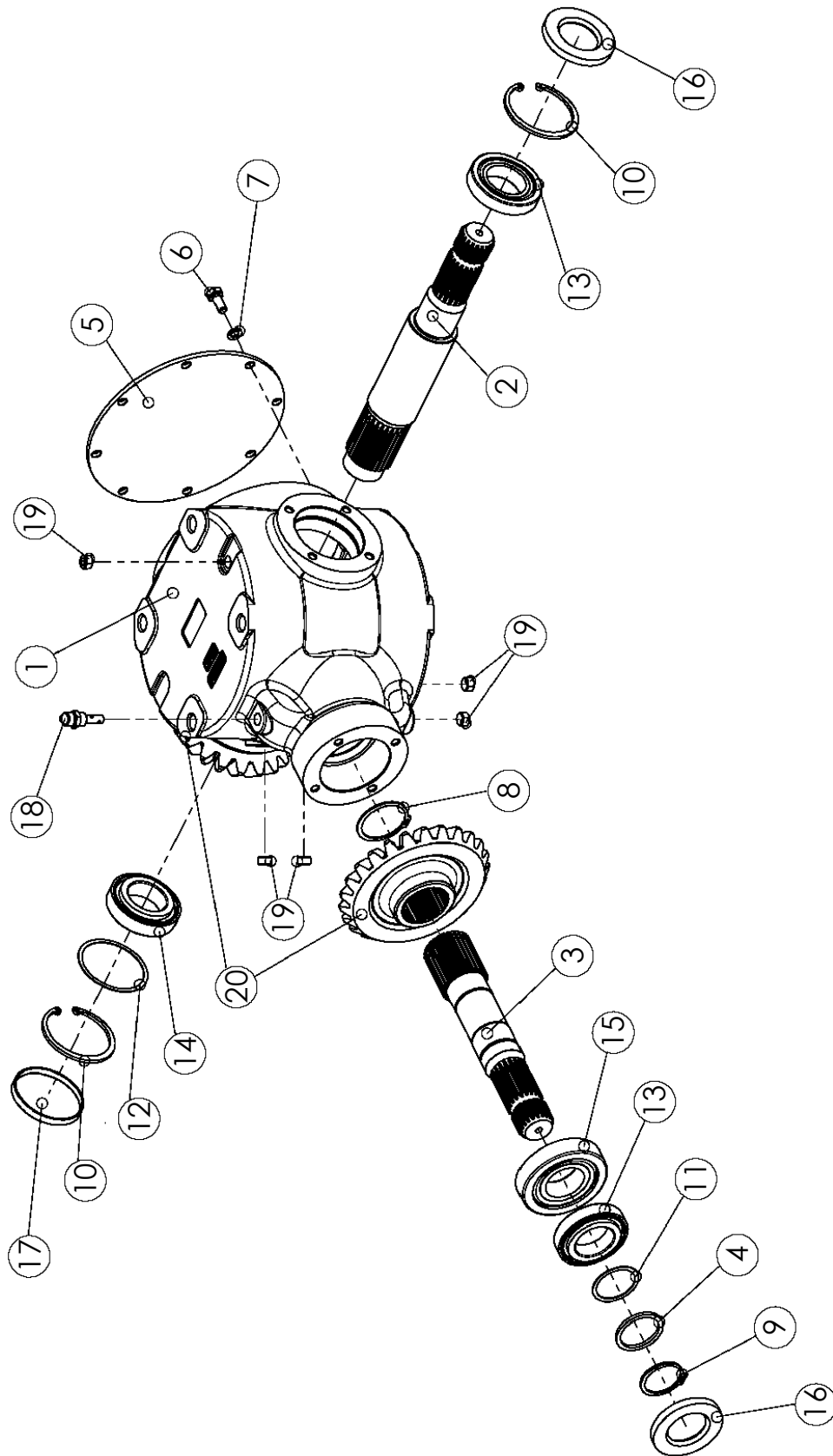

## GEARBOX 1.25:1 L #305601

ITEM	PART NO.	DESCRIPTION	QTY
1	305823	HOUSING	1
2	305826	SHAFT	1
3	305825	SHAFT Z-2155	1
4	305829	2155 G-BOX SPACER 50.2X60.3X4	1
5	305830	COVER Ø254 S2150	1
6	68185	SCREW-BOLT HEX M10 X25 CL8.8	8
7	68186	WASHER	8
8	305832	CIRCLIP EXTERNAL 60X2.00 DIN471	1
9	305834	CIRCLIP EXTERNAL 50X3.00 DIN471/2 THICK	1
10	305835	INTERNAL SNAP RING 90X4	2
11	305836	SHIM KIT Ø50MM SHAFT (59.8X50.2)	1
12	305837	SHIM KIT Ø90MM BORE (89.8X80.2)	1
13	305839	T. ROLLER BEARING 50X90X21.75 30210	2
14	305840	T. ROLLER BEARING 50X90X24.75 32210	1
15	305841	T. ROLLER BEARING 50X110X29.25 30310	1
16	305899	OIL SEAL 50X90X10	2
17	305845	OIL SEAL CAP 90X10	1
18	305846	BREATHER PLUG	1
19	54215	OIL PLUG	5
20	305849	BEVEL GEAR SET R=1.25 S2150	1

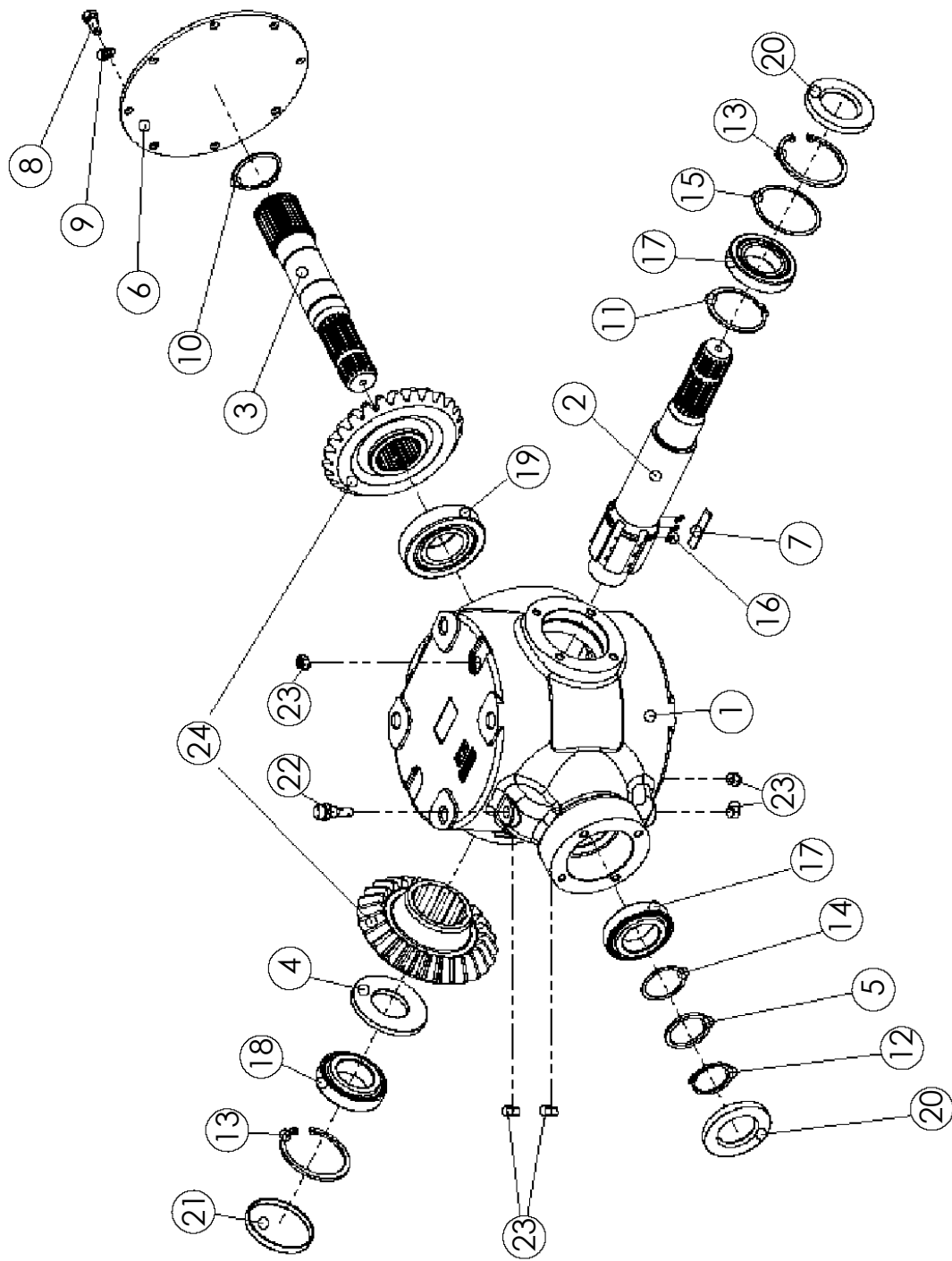



## GEARBOX 1:1 W/OVERRUN CLUTCH #305602

ITEM	PART NO.	DESCRIPTION	QTY
1	305823	HOUSING	1
2	305827	SHAFT	1
3	305825	SHAFT Z-2155	1
4	305828	SPACER 8MM S2155 W/RL	1
5	305829	2155 G-BOX SPACER 50.2X60.3X4	1
6	305830	COVER Ø254 S2150	1
7	305831	RATCHET S2155 W/RL L=60	6
8	68185	SCREW-BOLT HEX M10 X 25 CL8.8	8
9	68186	WASHER	8
10	305832	CIRCLIP EXTERNAL 60X2.00 DIN471	1
11	305833	CIRCLIP EXTERNAL 72X2.50 DIN471	1
12	305834	CIRCLIP EXTERNAL 50X3.00 DIN471/2 THICK	1
13	305835	INTERNAL SNAP RING 90X4	2
14	305836	SHIM KIT Ø50MM SHAFT (59.8X50.2)	1
15	305837	SHIM KIT Ø90MM BORE (89.8X80.2)	1
16	59960	SPRING-GEAROX SHAFT	18
17	305839	T. ROLLER BEARING 50X90X21.75 30210	2
18	305840	T. ROLLER BEARING 50X90X24.75 32210	1
19	305841	T. ROLLER BEARING 50X110X29.25 30310	1
20	305899	OIL SEAL 50X90X10	2
21	305845	OIL SEAL CAP 90X10	1
22	305846	BREATHER PLUG	1
23	54215	OIL PLUG	5
24	305848	BEVEL GEAR SET R=1:1 -2155- RL	1

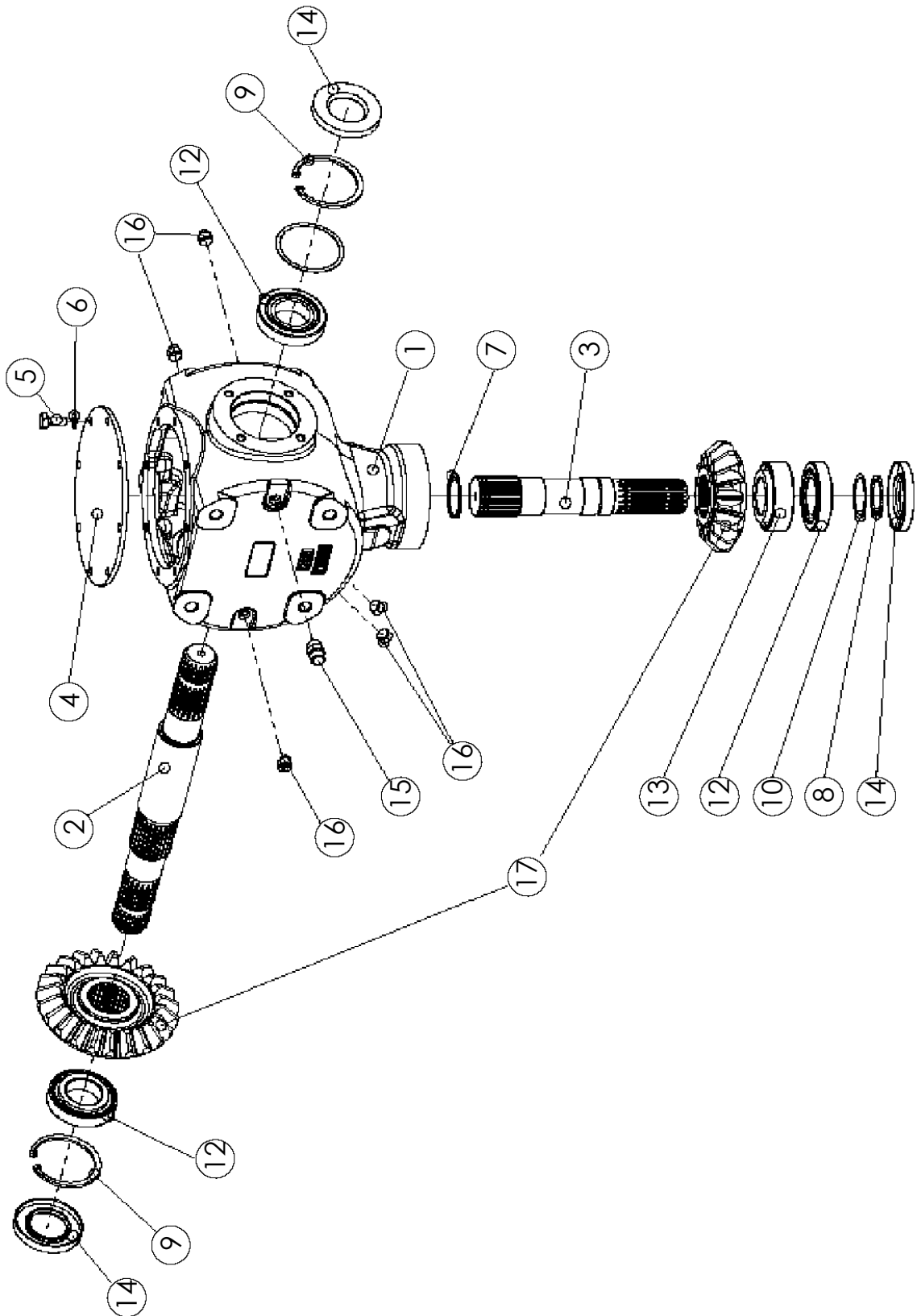

## GEARBOX T 1:1.35 #305603

ITEM	PART NO.	DESCRIPTION	QTY
1	68181	HOUSING	1
2	68193	SHAFT-THRU	1
3	68194	SHAFT	1
4	68184	SLEEVE	1
5	68185	SCREW-BOLT HEX M10 X 25 CL8.8	8
6	68186	WASHER	8
7	52521	SNAP RING: EXTERNAL	1
8	54209	SNAP RING	1
9	54210	SNAP RING	2
10	64421	KIT-SPACER RING	1
11	64422	KIT-SPACER RING	1
12	54212	BEARING ROLLER	3
13	68187	BEARING-ROLLER	1
14	54214	SEALING RING	3
15	54204	VENT PLUG	1
16	54215	OIL PLUG	5
17	68188	GEAR SET	1

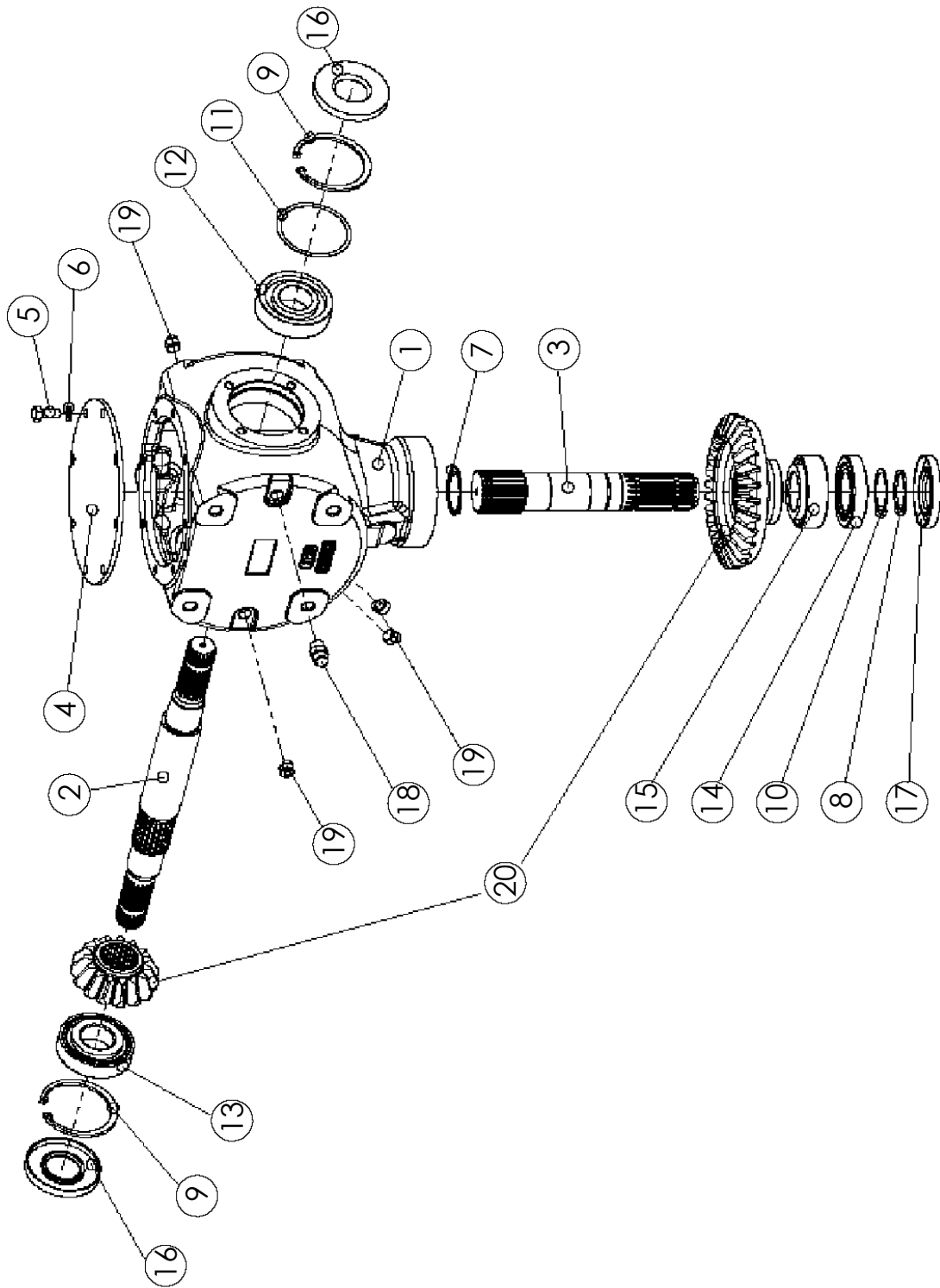

## GEARBOX T 1.93:1 #305604

ITEM	PART NO.	DESCRIPTION	QTY
1	305822	HOUSING	1
2	305824	SHAFT	1
3	68194	SHAFT	1
4	68184	SLEEVE	1
5	68185	SCREW-BOLT HEX M10 X 25 CL8.8	8
6	68186	WASHER	8
7	52521	SNAP RING: EXTERNAL	1
8	54209	SNAP RING	1
9	305835	INTERNAL SNAP RING 90X4	2
10	64421	KIT-SPACER RING	1
11	305837	SHIM KIT Ø90MM BORE (89.8X80.2)	1
12	305838	BALL BEARING 40X90X23 6308	1
13	305842	T. ROLLER BEARING 40X90X25.25 30308	1
14	54212	BEARING ROLLER	1
15	68187	BEARING-ROLLER	1
16	305843	OIL SEAL 40X90X10	2
17	54214	SEALING RING	3
18	305845	OIL SEAL CAP 90X10	1
19	54215	OIL PLUG	5
20	305847	BEVEL GEAR	1

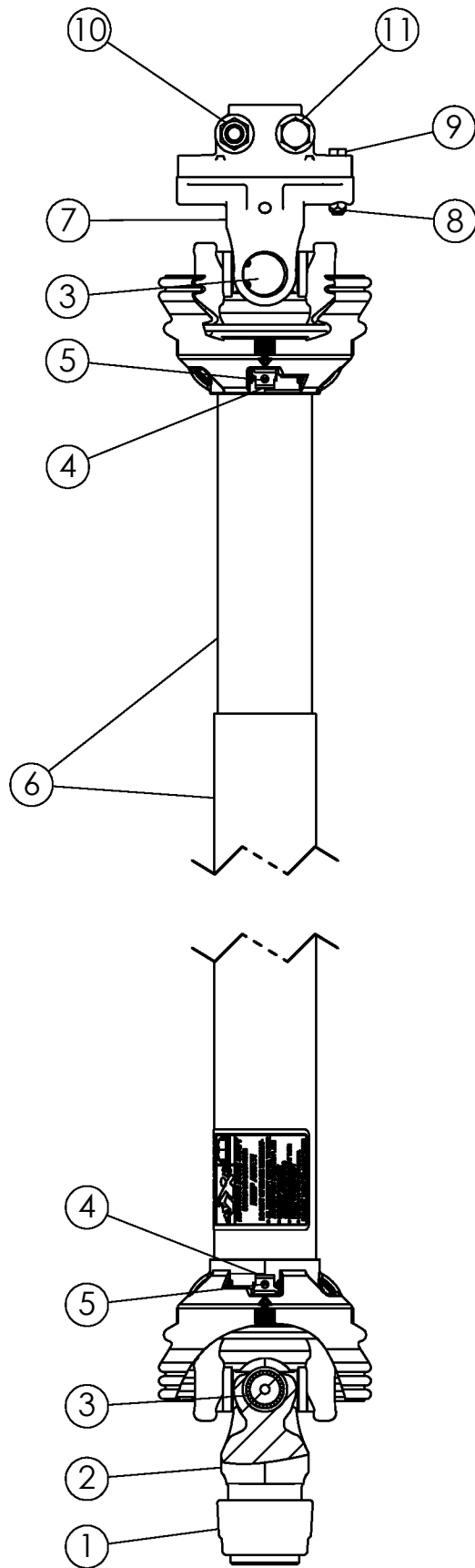

**PTO STD DRIVELINE #305691**  
**1.75"-20 SPLINE**

ITEM	PART NO.	DESCRIPTION	QTY
1	62123	KT-SAFETY SLIDE LOCK REPAIR 1.750"	1
2	305915	YOKE ASSY-SAFETY SLIDE LOCK 1.750" CAT 6 STD	1
3	305910	KT-CROSS & BEARING 55E SERIES	2
4	64398	KT-NYLON REPAIR UNIVERSAL	2
5	54161	ZERK-DRIVE LUBE FTG (PRESSED IN)	4
6	305917	GUARD SET-STD PTO DEF	1
7	305911	ASSY-BALL SHEAR DEF	1
8	1018706	NUT-TOPLOCK: .44 NC GR5 ZP	1
9	1030875	BOLT-HEX: .44 X 2.00 NC GR5 ZP	1
10	305913	NUT-FLG TOPLOCK: .625 NC GR8 ZP	2
11	305914	BOLT-FLG: .625 X 3.50 NC GR8 ZP	2

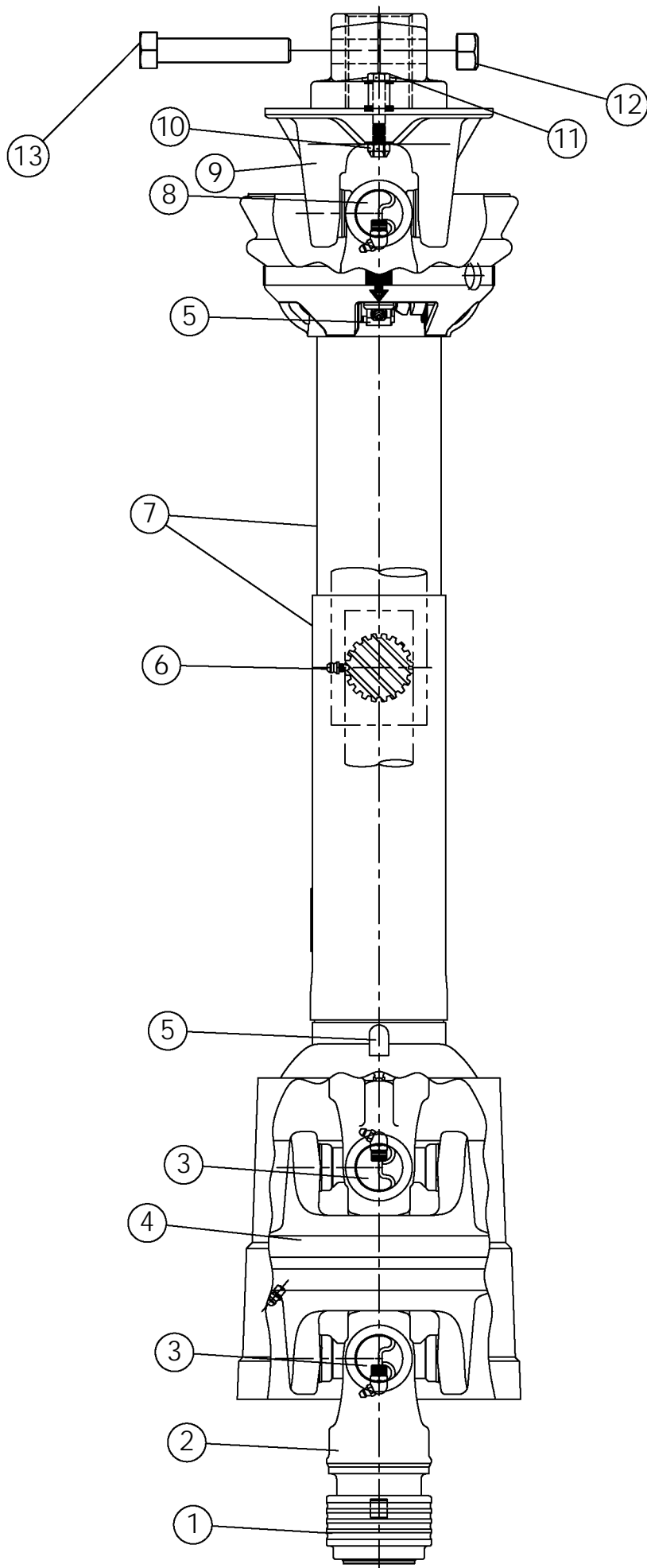



**PTO CV DRIVELINE #305690**  
**1.75" - 20 SPLINE**

ITEM	PART NO.	DESCRIPTION	QTY
1	62123	KT-SAFETY SLIDE LOCK REPAIR 1.750"	1
2	305902	YOKE ASSY-SAFETY SLIDE LOCK 1.750" CAT 6 CV	1
3	301841	KT-CROSS & BEARING CAT 6	2
4	305904	HOUSING-CV CENTER ASSY CAT 6	1
5	64398	KT-NYLON REPAIR UNIVERSAL	2
6	54161	ZERK-DRIVE LUBE FTG (PRESSED IN)	4
7	305906	GUARD SET-CVPTO DEF	1
8	305910	KT-CROSS & BEARING 55E SERIES	1
9	305911	ASSY-BALL SHEAR DEF	1
10	1018706	NUT-TOPLOCK: .44 NC GR5 ZP	1
11	1030875	BOLT-HEX: .44 X 2.00 NC GR5 ZP	1
12	305913	NUT-FLG TOPLOCK: .625 NC GR8 ZP	2
13	305914	BOLT-FLG: .625 X 3.50 NC GR8 ZP	2

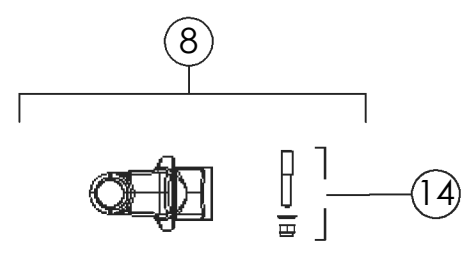
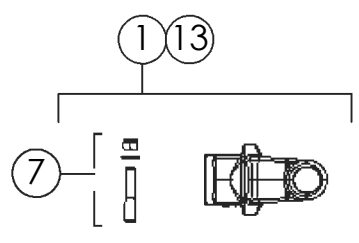
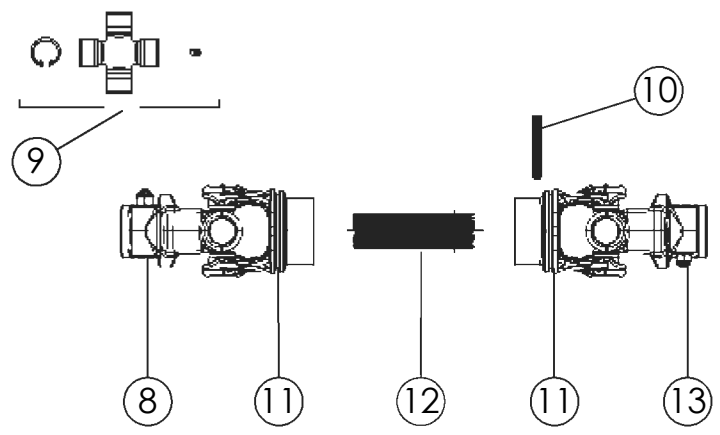
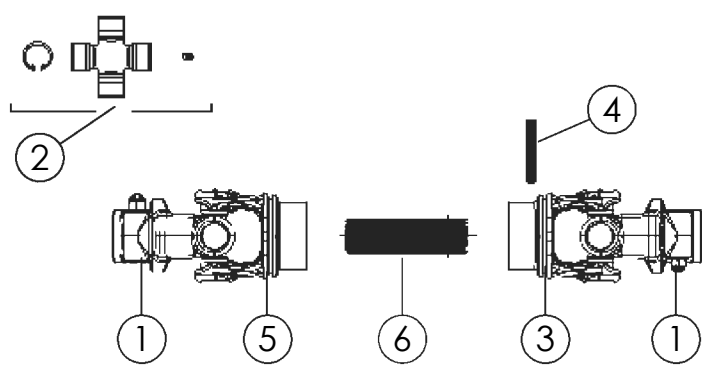

## SIDE DRIVELINE #305611

ITEM	PART NO.	DESCRIPTION	QTY
1	305444	YOKE COUPLER TAPER PIN 1.375	2
2	305445	CROSS KIT	2
3	305447	YOKE S9	1
4	305446	PIN-ROLL	1
5	305448	YOKE TUBE-OUTER S9	1
6	305449	TUBE-CARDAN (N/A PURCHASE 305611)	1
7	305546	KIT-TAPER PIN	2

## SIDE DRIVELINE #305612

7	305546	KIT-TAPER PIN	1
8	68731	YOKE-COUPLER TAPER PIN 1.750	1
9	305445	CROSS KIT	2
10	305446	ROLL-PIN	1
11	305448	YOKE TUBE-OUTER S9	2
12	305549	TUBE-CARDAN (N/A PURCHASE 305612)	1
13	305444	YOKE-COUPLER TAPER PIN 1.375	1
14	305546	KIT-TAPER PIN	1

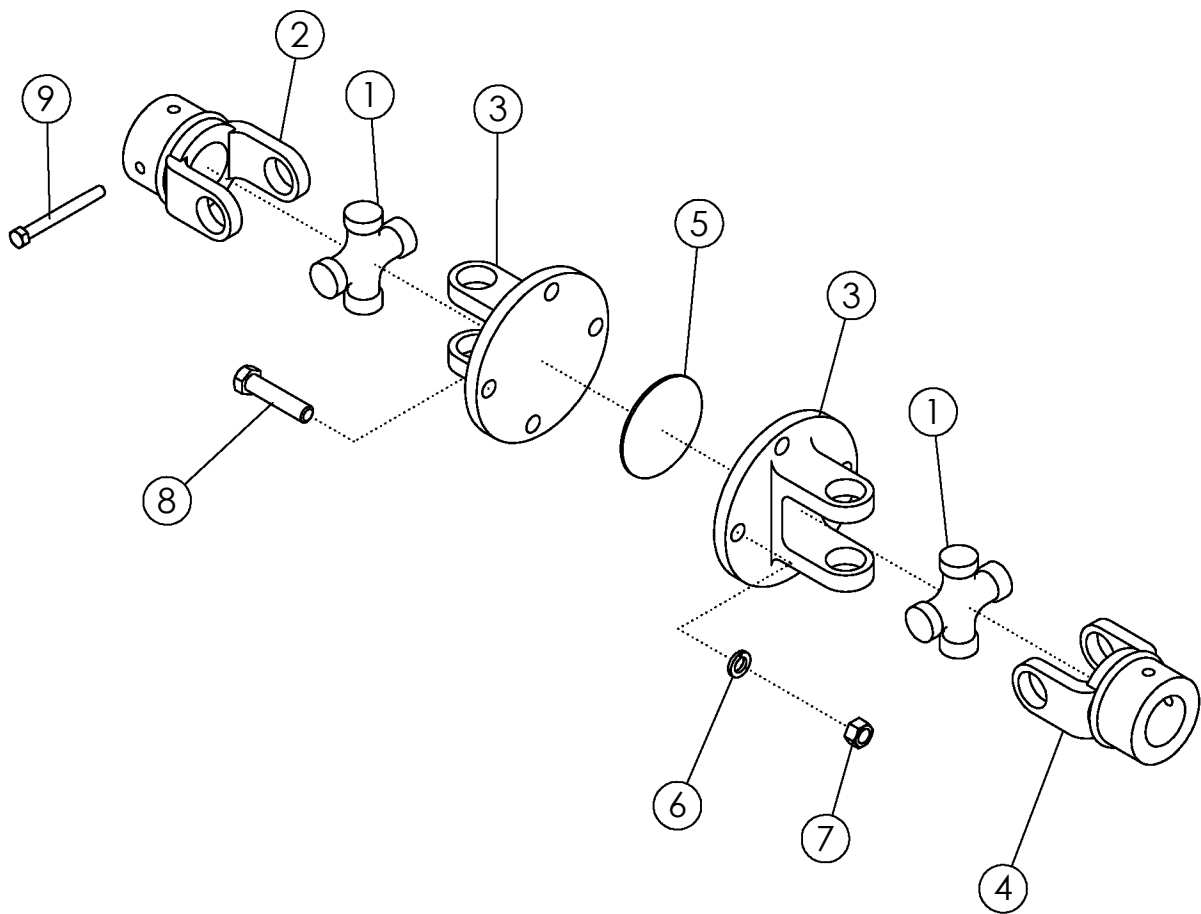

## COUPLER-UNIVERSAL JOINT #68443

ITEM	PART NO.	DESCRIPTION	QTY
1	54235	CROSS KIT	2
2	68731	YOKE-COUPLER TAPER PIN 1.750	1
3	68780	FLANGE-YOKE COUPLER	2
4	68732	YOKE COUPLER 1.750	1
5	68781	PLATE-LINER COUPLER	1
6	68591	WASHER-LOCK: M14	4
7	68444	NUT-HEX: M14	4
8	69019	BOLT-HEX: M14 X 2.0 X L50 CL8.8 ZP	4
9	68782	KIT-TAPER PIN 1.750	1

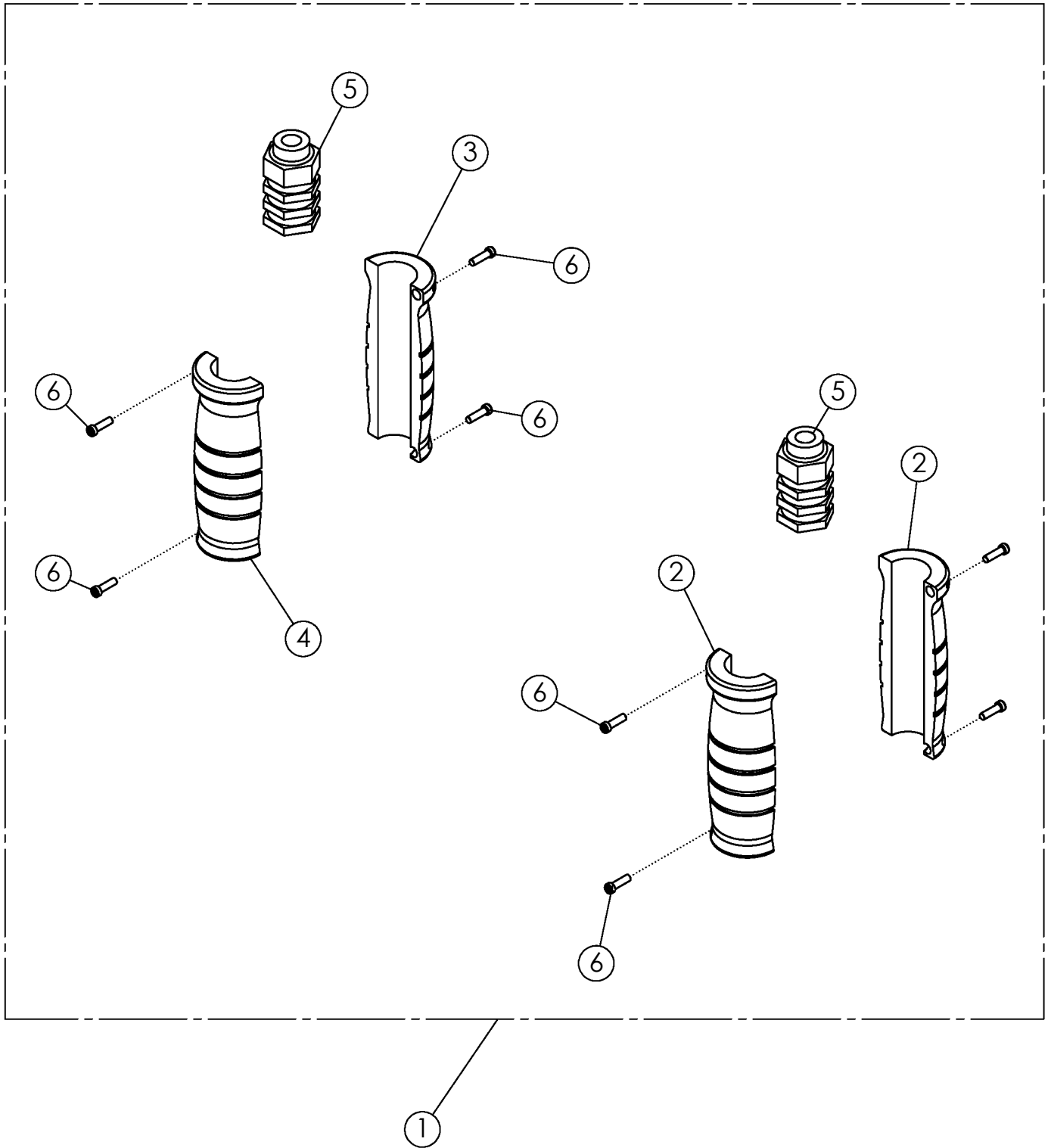

## HYDRAULIC LABEL ASSY

ITEM	PART NO.	DESCRIPTION	QTY
1	301920*	HYD LABEL: .50 ORANGE/GRAY SET	1
	301902*	HYD LABEL: .50 BLUE/GRAY SET	
	301917*	HYD LABEL: .50 YELLOW/GRAY SET	
	301914*	HYD LABEL: .50 GREEN/GRAY SET	
	301911*	HYD LABEL: .50 BLACK/GRAY SET	
	301908*	HYD LABEL: .50 RED/GRAY SET	
	302230*	HYD LABEL: .50 RED/GREEN SET	
	302226*	HYD LABEL: .50 BLACK/ORANGE SET	
	302227*	HYD LABEL: .50 BLUE/YELLOW SET	
	301923*	HYD LABEL: .75 GREEN/GRAY SET	
	301928*	HYD LABEL: .75 YELLOW/GRAY SET	
2	301915	HYD LABEL: .50 GREEN HALF EXTEND	2
	301903	HYD LABEL: .50 BLUE HALF EXTEND	
	301909	HYD LABEL: .50 RED HALF EXTEND	
	301918	HYD LABEL: .50 YELLOW HALF EXTEND	
	301921	HYD LABEL: .50 ORANGE HALF EXTEND	
	301912	HYD LABEL: .50 BLACK HALF EXTEND	
	301921	HYD LABEL: .50 ORANGE HALF EXTEND	
	301925	HYD LABEL: .75 GREEN HALF EXTEND	
	301929	HYD LABEL: .75 YELLOW HALF EXTEND	
	302304	HYD LABEL: .75 RED HALF EXTEND	
3	301916	HYD LABEL: .50 GREEN HALF RETRACT	1
	301904	HYD LABEL: .50 BLUE HALF RETRACT	
	301910	HYD LABEL: .50 RED HALF RETRACT	
	301919	HYD LABEL: .50 YELLOW HALF RETRACT	
	301922	HYD LABEL: .50 ORANGE HALF RETRACT	
	301913	HYD LABEL: .50 BLACK HALF RETRACT	
	301922	HYD LABEL: .50 ORANGE HALF RETRACT	
	301926	HYD LABEL: .75 GREEN HALF RETRACT	
	301930	HYD LABEL: .75 YELLOW HALF RETRACT	
	302305	HYD LABEL: .75 RED HALF RETRACT	
4	301905	HYD LABEL: .50 GRAY HALF RETRACT	1
	301927	HYD LABEL: .75 GRAY HALF RETRACT	
5	301906	HYD LABEL: .50 CORE M & F O-RING	2
	301924	HYD LABEL: .75 CORE M & F O-RING	
6	301907	HYD LABEL: SET SCREW	8

\* COMES WITH ITEMS 2 THRU 6

# 69055 SNAP RING PLIERS

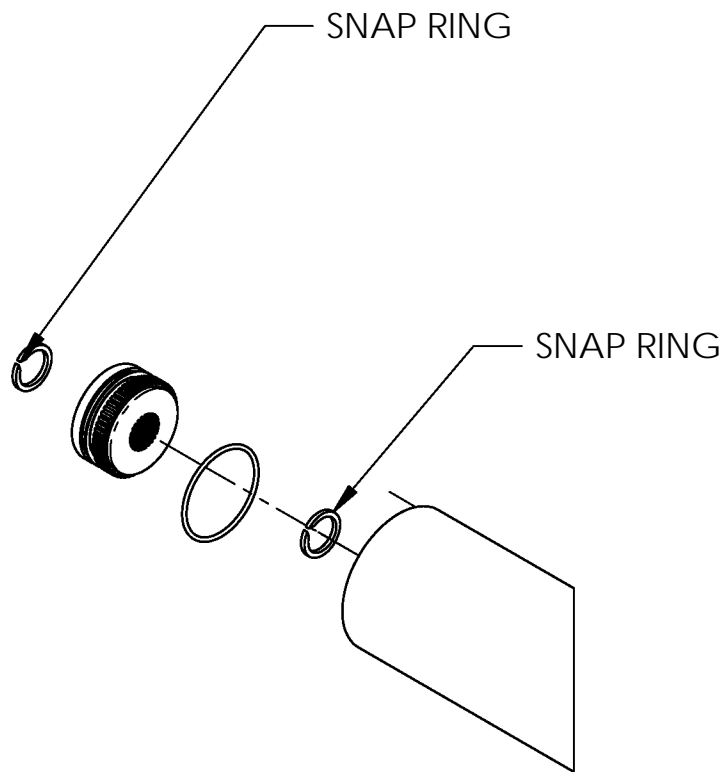
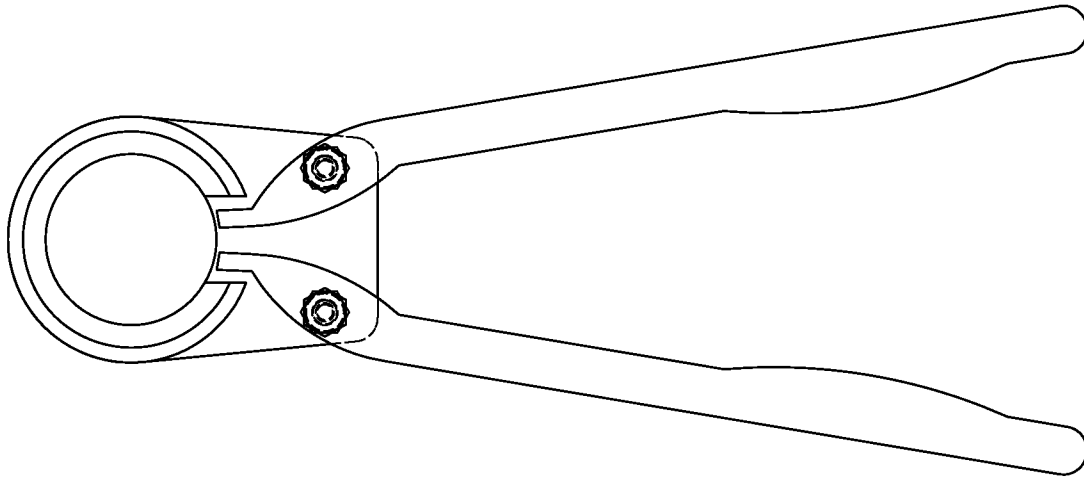

SHAFT REMOVED FOR CLARITY