

PARTS MANUAL

2023

2500 HARVESTER SCRUB

8 ROW 22

6 ROW 30

Amity
TECHNOLOGY



2800 7th Avenue North
Fargo, ND 58102

Phone: (701) 232-4199

Fax: (701) 234-1716

www.amitytech.com



TABLE OF CONTENTS

HITCH ASSEMBLY	1-2
LIFTER STRUT	3-10
ROW FINDER	11-14
GUARDS & SHIELDS	15-18
DOOR ASSEMBLY	19-20
HARVESTER STAND (OPTIONAL)	21-22
APRON SHAFT	23-28
PADDLE SHAFT	29-32
CLEANING ROLLS	33-34
CLEANING ROLL MOUNTING PACKAGE	35-36
MAIN DRIVE	37-38
MAIN DRIVE: ONBOARD OPTION	39-40
CLEANING ROLL DRIVE	41-42
APRON/PADDLE SHAFT DRIVE	43-44
TANK	45-46
ELEVATOR AND BOOM ASSEMBLY	47-50
BOOM EXTENSION 50MM/56MM (OPTIONAL)	51-52
BOOM EXTENSION 56MM (OPTIONAL)	53-54
REAR SCRUB	55-58
REAR SCRUB: BELTED CHAIN	59-60
REAR SCRUB: G1 BELTED CHAIN HIGH PROFILE 55MM	61-64
REAR SCRUB-G2	65-72
REAR SCRUB DRIVE: SINGLE MOTOR	73-76
STANDARD REAR STRUTS 11.2 X 24	77-80
SINGLE TIRE STRUT	81-82
STEERABLE REAR STRUTS	83-86
ROW FINDER & HITCH HYDRAULICS	87-92
VALVE GROUP: DUAL MOTOR SCRUB	93-94
TANK HYDRAULICS	95-96
HYDRAULIC TANK	97-98
CYLINDER STOP KIT	99-100
LIGHT KIT	101-102
KT-JD TOUCHSET 2200-2500 MODEL #302865	103-104
PTO DRIVELINE #301558 & #301575	105-106
GEARBOX (1.81:1) #62015	107-108
SELECTOR VALVE #58470	109-110
ROW FINDER VALVE #301150	111-112
SPROCKET #54824	113-114
BELT TIGHTENER #56422	113-114
SLIP CLUTCH (IN-LINE) #57926	115-116
SLIP CLUTCH/SPROCKET #57993	115-116
SLIP CLUTCH/SPROCKET #58335	115-116
SLIP CLUTCH/SPROCKET #69630	117-118

IDLER PULLEY #56409	119-120
SPROCKET IDLER #56851	119-120
REVERSE PULLEY	121-122
ROLLERS	123-124
DRIVELINE COMPONENTS	125-126
SCRUB DRIVELINE ASSEMBLY	127
BELTED CHAIN LAP JOINT- STANDARD	128
BELTED CHAIN LAP JOINT- HIGH PROFILE	129
BELT REPAIR KIT	130
TOOL CUTTER	131-132
DECALS	133-139
HYDRUALIC LABEL ASSY	141-142

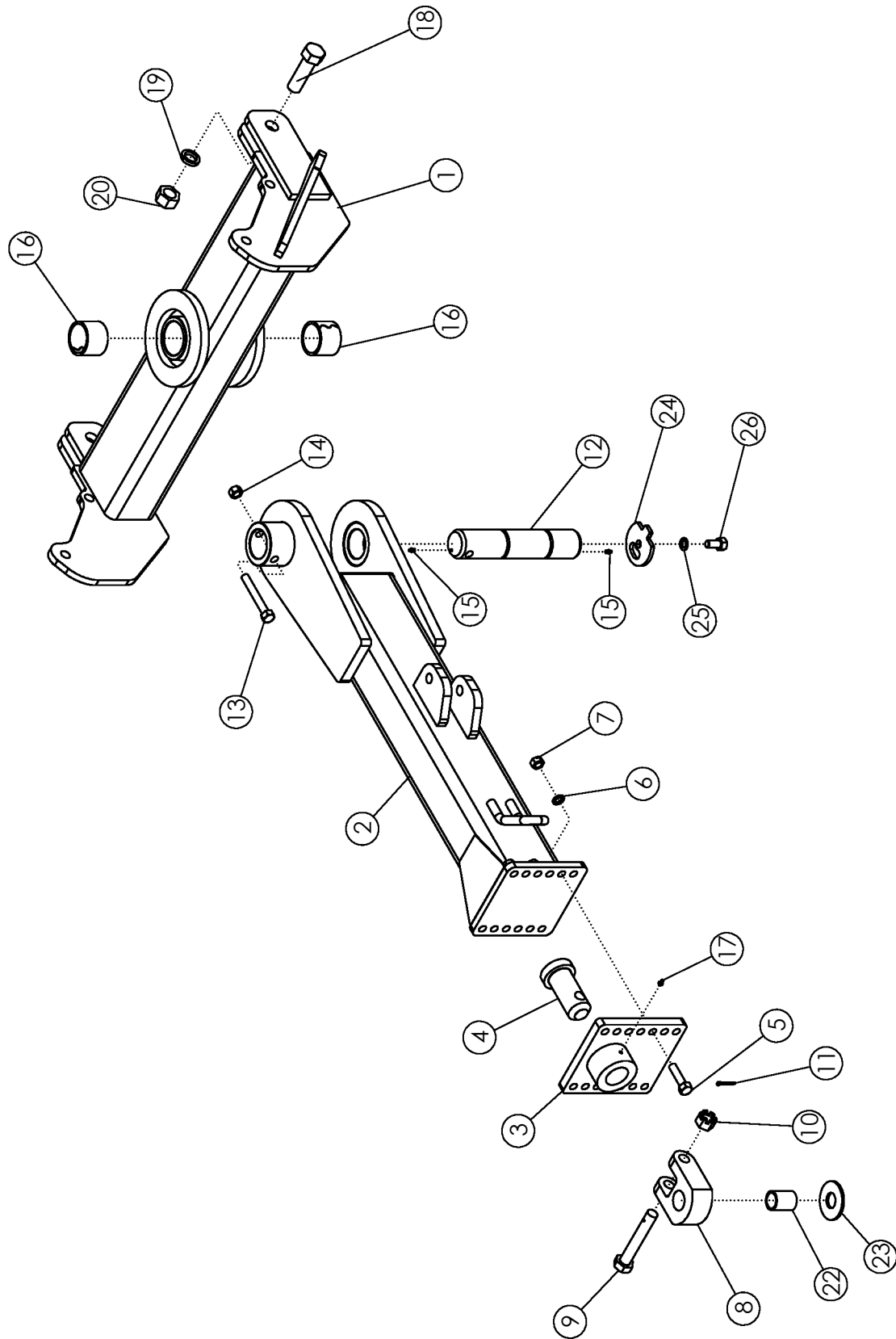

HITCH ASSEMBLY

ITEM	PART NO.	DESCRIPTION	QTY
1	301660	WLDMT - HITCH PIVOT 6R/8R STD	1
2	301582	WLDMT - DRAWPOLE EXTENDED	1
3	57930	WLDMT-HITCH PLATE	1
4	62101	WLDMT-PIN	1
5	1012059	BOLT-HEX: .75 X 3.00 NC GR5 ZP	6
6	1012061	WASHER-LOCK: .75 ZP	6
7	1011620	NUT-HEX: .75 NC	6
8	64476	PLATE-PULL HITCH	1
9	62477	BOLT-HITCH DRILLED	1
10	62088	NUT-SLOTTED: 1.13 NC GR5 ZP	1
11	1013473	PIN-COTTER: .19 X 2.00 NP	1
12	301590	PIN-HITCH PIVOT	1
13	69911	BOLT-HEX: .75 X 5.5 NC GR5 ZP	1
14	1017000	NUT-TOPLOCK: .75 NC GR5 ZP	1
15	1030883	ZERK-GREASE: .3125 UNF STRAIGHT	2
16	301591	SPRING BUSHING 3.50 X 3.00 X 2.50	2
17	1011748	ZERK - GREASE: .25 UNF STRAIGHT	1
18	72021	BOLT-HEX: 1.38 X 4.50 NC GR5 ZP	2
19	1030760	WASHER-LOCK: 1.38 ZP	2
20	1030758	NUT-HEX: 1.38 NC ZP	2
21	69256	CHAIN-SAFETY 41000# (NOT SHOWN)	1
22	64614	TUBE-SPACER 2.0 X 1.63	1
23	58925	WASHER-HARDENED 4.000 X 1.625	1
	68645	WASHER-FLAT: SPCL 2.125 X 4.50 X .184	
24	303568	PLATE-HITCH PIN RETAINER	1
25	1012061	WASHER-LOCK: .75 ZP	1
26	58367	BOLT-HEX: .75 X 1.50 NC GR5 ZP	1

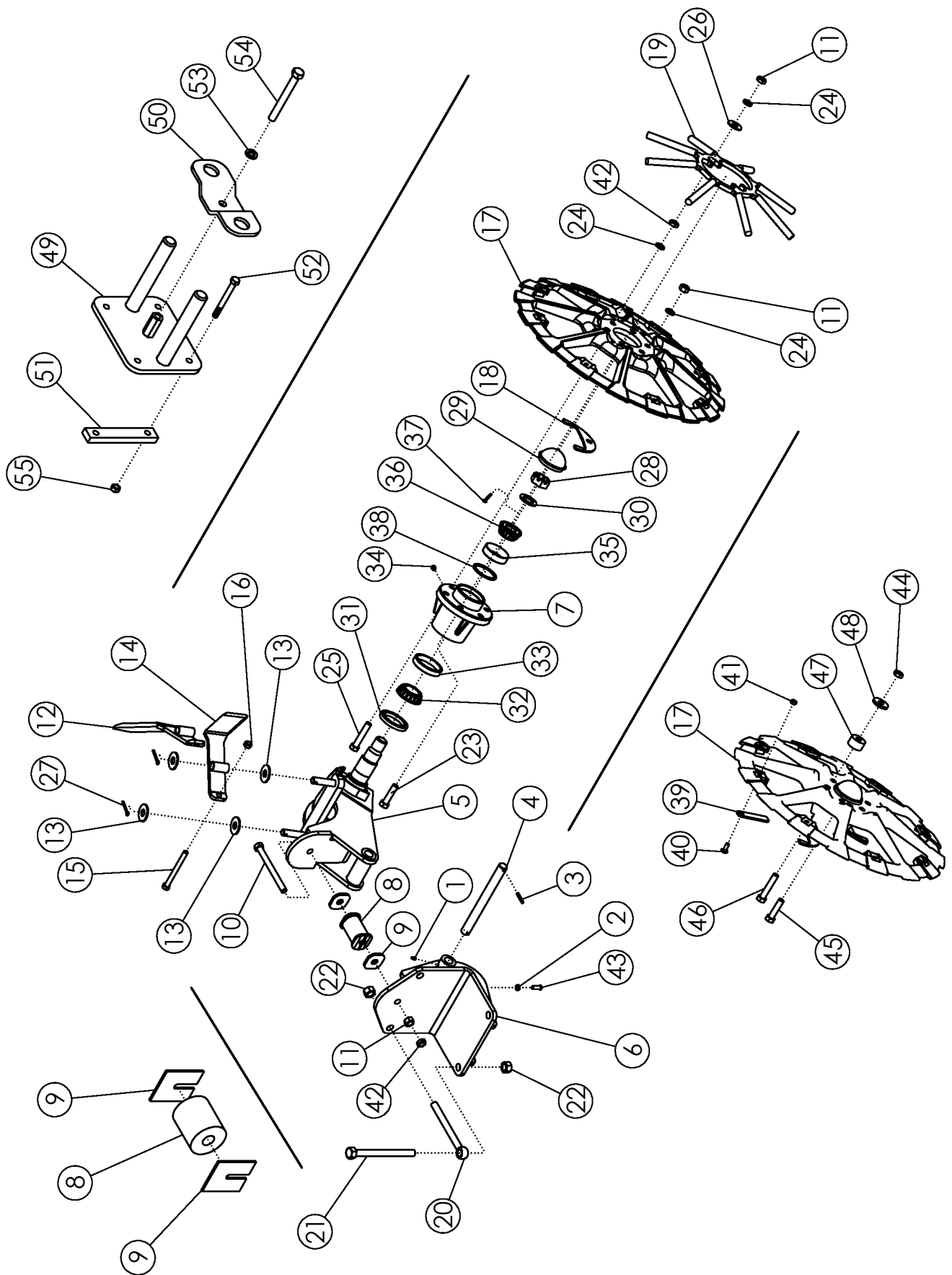

LIFTER STRUT

ITEM	PART NO.	DESCRIPTION	QTY
1	1011748	ZERK - GREASE: .25 UNF	2
2	1013519	NUT-JAM: .38 NC GR2 ZP	2
3	59398	PIN-ROLL: .25 X 1.50 ZP	2
4	69907	SHAFT-STRUT	1
5	50142	WLDMT-STRUT SPINDLE ASSY	1
6	50146	WLDMT-STRUT BRACKET	1
7	63655	HUB-MACHINED	2
8	50134	WLDMT-SPACER ZP	1
	51542	BUMPER-RUBBER	1
9	50137	WASHER SQUARE ZP	2
	50139	PLATE-LIFTER STRUT SPACER ZP	4
10	1030761	BOLT-HEX: .63 X 7.00 NC GR 8 ZP	1
11	1011578	NUT-HEX: .63 NC GR5 ZP	13
12	50715	WLDMT-SCRAPER RH	1
13	1030702	WASHER-FLAT: .75 ZP	4
14	50716	WLDMT-SCRAPER LH	1
15	1011669	BOLT-HEX: .50 X 6.00 NC GR5 ZP	1
16	1027461	NUT-TOPLOCK: .50 NC GR5 ZP	1
17	69855	LIFTER WHEEL-MACH (FILLER)	2
	300734	LIFTER WHEEL HARD PAINTED	
18	50747	PLATE-LIFTER WHEEL SPACER ZP (OPTIONAL)	AR
19	63880	WLDMT-WHEEL FILLER (OPTIONAL)	2
20	64135	BOLT-EYE: .75 X 8.00 ZP	2
21	64136	BOLT-HEX: .75 X 8.50 NC GR5 ZP	2
22	1017000	NUT-TOPLOCK: .75 NC GR5 ZP	4
23	1024447	BOLT-HEX: .63 X 2.75 NC GR5 ZP	8
24	1011813	WASHER-LOCK: .63 ZP	16
25	65825	BOLT-HEX: .63 X 3.25 NC GR5 ZP	4
26	1013024	WASHER-FLAT: .63 ZP	4
27	1013473	PIN-COTTER: .19 X 2.00 NP	2
28	1016367	NUT-SPINDLE: 1.38 NF NP	2
29	63624	HUB CAP ROUNDED ZP	2
30	1030765	BUSHING-MACHINED: 1.38 NR 10 GA	2
31	53632	SEAL	2
32	53634	CONE-BEARING INNER	2
33	53636	CUP-BEARING INNER	2
34	1030766	ZERK - GREASE .13 NPT STRAIGHT	2
35	53635	CUP-BEARING OUTER	2
36	53633	CONE-BEARING OUTER	2
37	64012	PIN-COTTER: .19 X 3.00 NP	2

CONTINUE

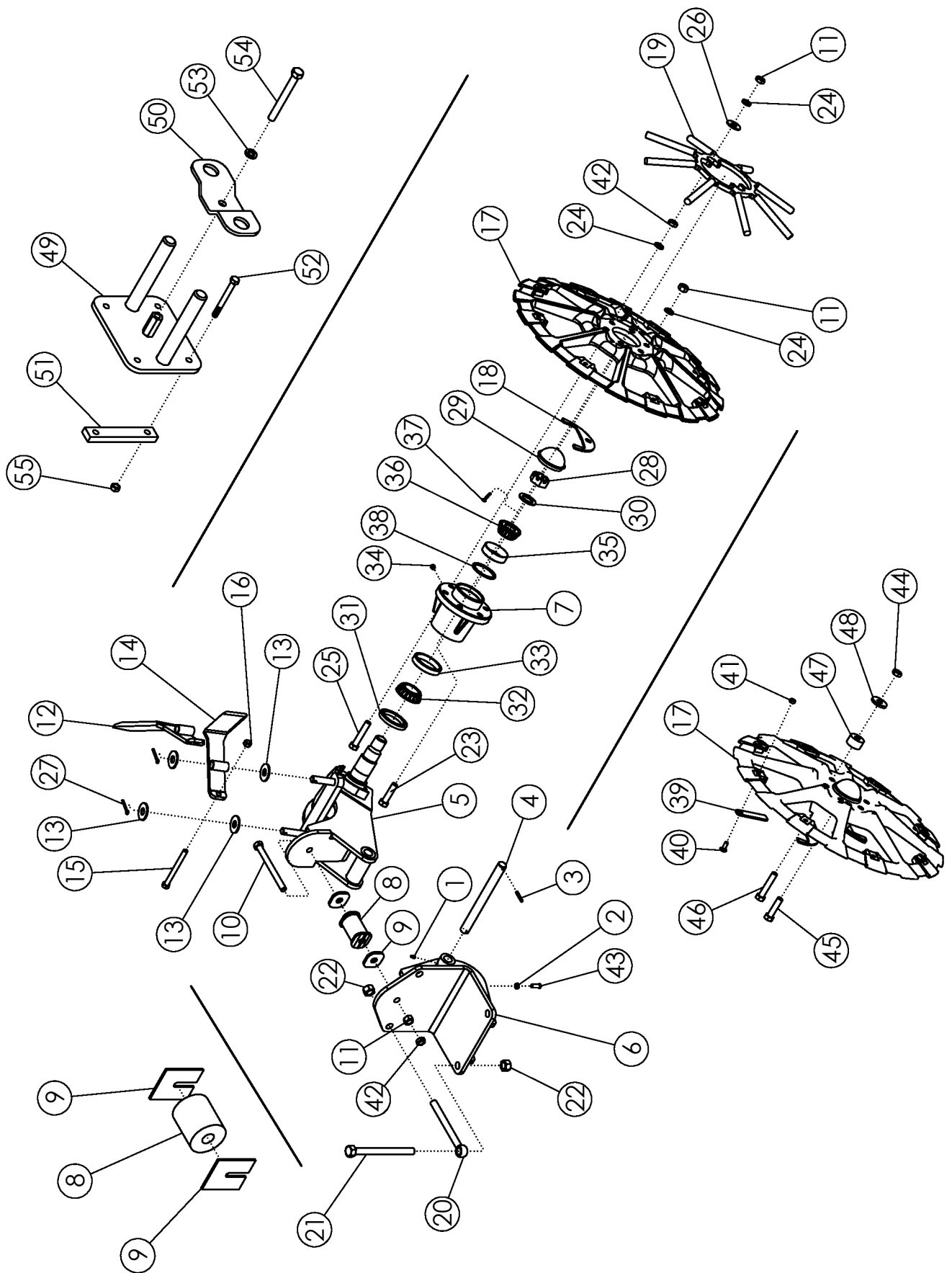

LIFTER STRUT (CONTINUED)

ITEM	PART NO.	DESCRIPTION	QTY	
38	64674	RACE-SPACER (.120)	AR	
39	300097	PLATE-LIFTER WHEEL FILLER	16	
40	59488	BOLT-CRG: .38 X 1.00 NC GR5 ZP	16	
41	303731	NUT-FLANGE TOPLOCK .38 NC YZP	16	
42	1026259	NUT-JAM: .63 NC GR2 ZP	5	
43	50813	SCREW-SET: SQ HD .38 X 1.00 ZP	2	
OPTIONAL URETHANE BUSHING				
44	1016595	NUT-TOPLOCK: .63 GR5 ZP	12	
45	59093	BOLT-HEX: .63 X 3.75 NC GR5 ZP	8	
46	1013935	BOLT-HEX: .63 X 4.50 NC GR5 ZP	4	
47	51705	BUSHING	12	
	301975	BUSHING-URETHANE .67"		
48	301324	WASHER-CUSTOM: .668 ID X 1.875 OD X .235 TH	12	
OPTIONAL WHEEL FILLER BRACKET			6-8ROW	12 ROW
49	64658	WLDMT-WHEEL FILLER BRACKET	2	3
50	64659	PLATE-RETAINER	2	3
51	63372	BAR-BACKING	4	6
52	58176	BOLT-HEX: .38 X 3.50 NC GR5 ZP	8	12
53	1011581	WASHER-LOCK: .50 ZP	2	3
54	1011618	BOLT-HEX: .50 X 5.00 NC GR5 ZP	2	3
55	1016999	NUT-TOPLOCK: .38 NC GR5 ZP	8	12

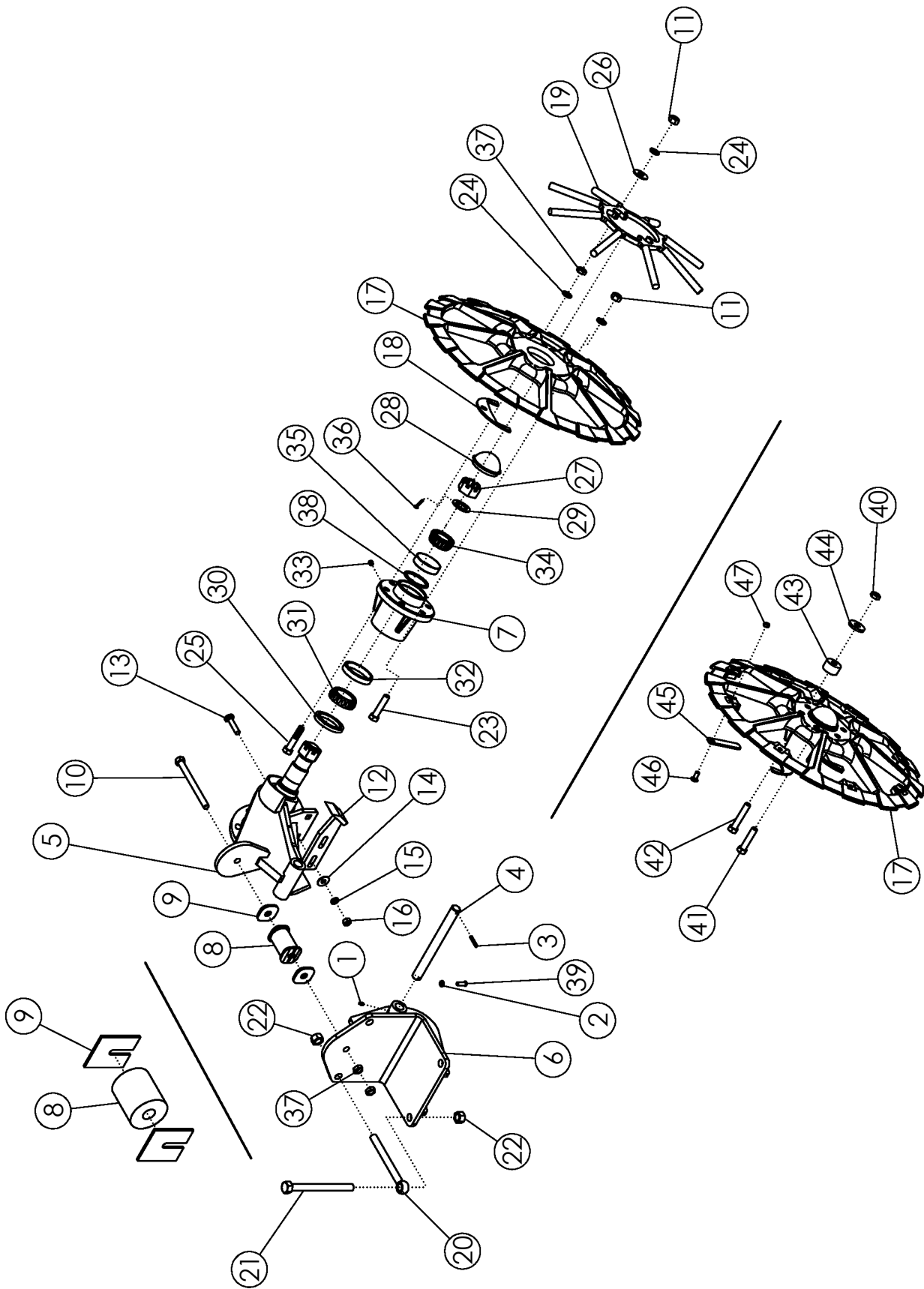

LIFTER STRUT - BOTTOM SCRAPER OPTION

ITEM	PART NO.	DESCRIPTION	QTY
1	1011748	ZERK - GREASE: .25 UNF	2
2	1013519	NUT-JAM: .38 NC GR2 ZP	2
3	59398	PIN-ROLL: .25 X 1.50 ZP	2
4	69907	SHAFT-STRUT	1
5	68095	WLDMT-SP LIFTER STRUT STD	1
6	50146	WLDMT-STRUT BRACKET	1
7	63655	HUB-MACHINED	2
8	50134	WLDMT-SPACER ZP	1
	51542	BUMPER-RUBBER	1
9	50137	WASHER SQUARE ZP	2
	50139	PLATE-LIFTER STRUT SPACER ZP	2
10	1030761	BOLT-HEX: .63 X 7.00 NC GR 8 ZP	1
11	1011578	NUT-HEX: .63 NC GR5 ZP	13
12	64369	WLDMT-SCRAPER	2
13	64685	BOLT-CRG: .50 X 2.25 NC GR5 ZP	2
14	1014443	WASHER-FLAT: .50 ZP	2
15	1011581	WASHER-LOCK: .50 ZP	2
16	1011577	NUT-HEX: .50 NC GR5 ZP	2
17	69855	LIFTER WHEEL-MACH (FILLER)	2
	300734	LIFTER WHEEL HARD PAINTED	
18	50747	PLATE-LIFTER WHEEL SPACER ZP	AR
19	63880	WLDMT-WHEEL FILLER (OPTIONAL)	2
20	64135	BOLT-EYE: .75 X 8.00 ZP	2
21	64136	BOLT-HEX: .75 X 8.50 NC GR5 ZP	2
22	1017000	NUT-TOPLOCK: .75 NC GR5 ZP	4
23	1024447	BOLT-HEX: .63 X 2.75 NC GR5 ZP	8
24	1011813	WASHER-LOCK: .63 ZP	16
25	65825	BOLT-HEX: .63 X 3.25 NC GR5 ZP	4
26	1013024	WASHER-FLAT: .63 ZP	4
27	1016367	NUT-SPINDLE: 1.38 NF NP	2
28	63624	HUB CAP ROUNDED ZP	2
29	1030765	BUSHING-MACHINED: 1.38 NR 10 GA	2
30	53632	SEAL	2
31	53634	CONE-BEARING INNER	2
32	53636	CUP-BEARING INNER	2
33	1030766	ZERK - GREASE .13 NPT STRAIGHT	2
34	53635	CUP-BEARING OUTER	2
35	53633	CONE-BEARING OUTER	2
36	64012	PIN-COTTER: .19 X 3.00 NP	2
37	1026259	NUT-JAM: .63 NC ZP	5
38	64674	RACE-SPACER (.120)	AR
39	50813	SCREW-SET: SQ HD .38 X 1.00 ZP	2

CONTINUED

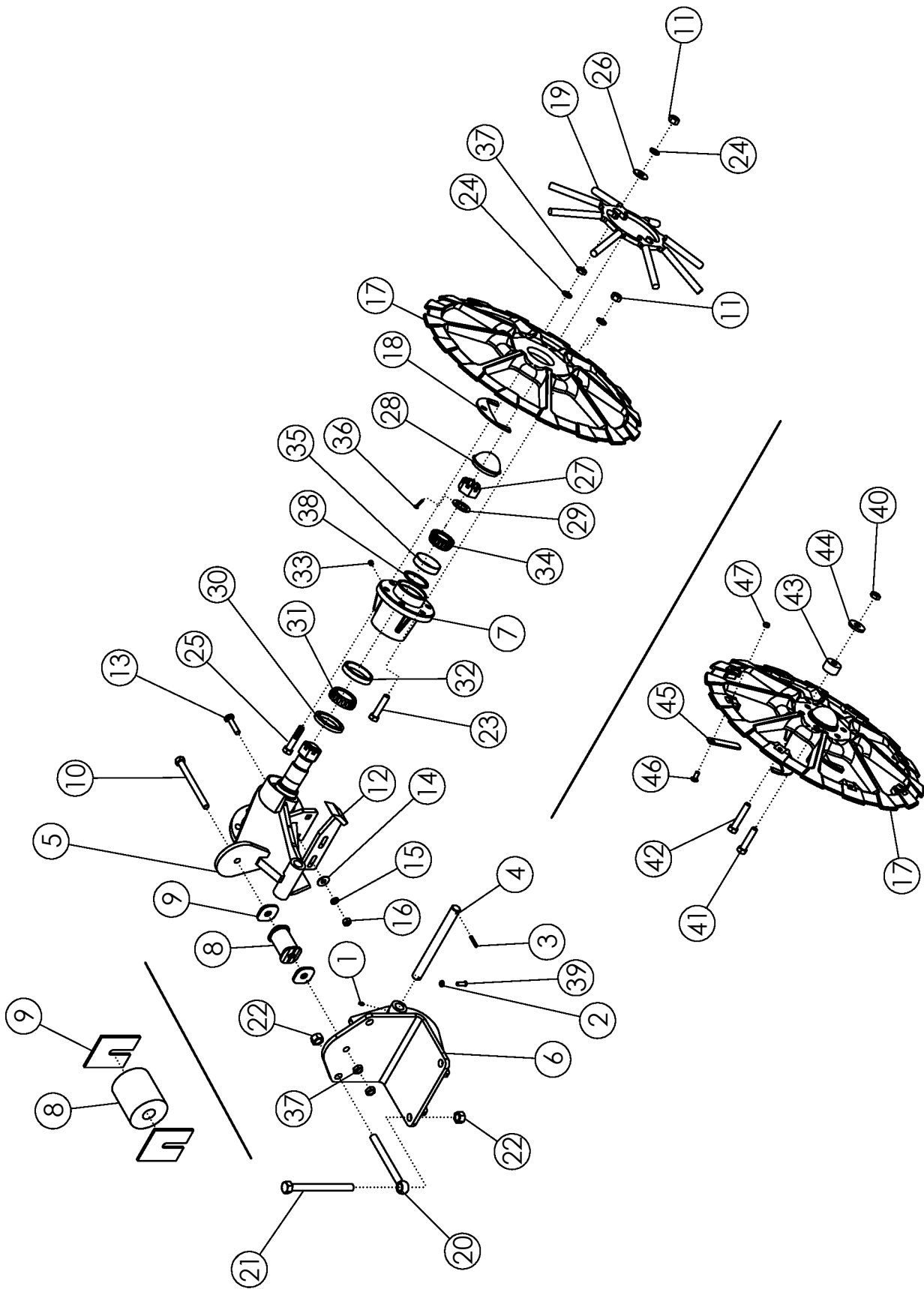

LIFTER STRUT - BOTTOM SCRAPER (CONTINUED)

ITEM	PART NO.	DESCRIPTION	QTY
OPTIONAL URETHANE BUSHING			
40	1016595	NUT-TOPLOCK: .63 GR5 ZP	12
41	59093	BOLT-HEX: .63 X 3.75 NC GR5 ZP	8
42	1013935	BOLT-HEX: .63 X 4.50 NC GR5 ZP	4
43	51705	BUSHING	12
	301975	BUSHING-URETHANE .67"	
44	301324	WASHER-CUSTOM: .668 ID X 1.875 OD X .235 TH	12
RIM FILLER KIT			
45	300097	PLATE-LIFTER WHEEL FILLER	16
46	59488	BOLT-CRG: .38 X 1.00 NC GR5 ZP	16
47	303731	NUT-FLANGE TOPLOCK .38 NC YZP	16

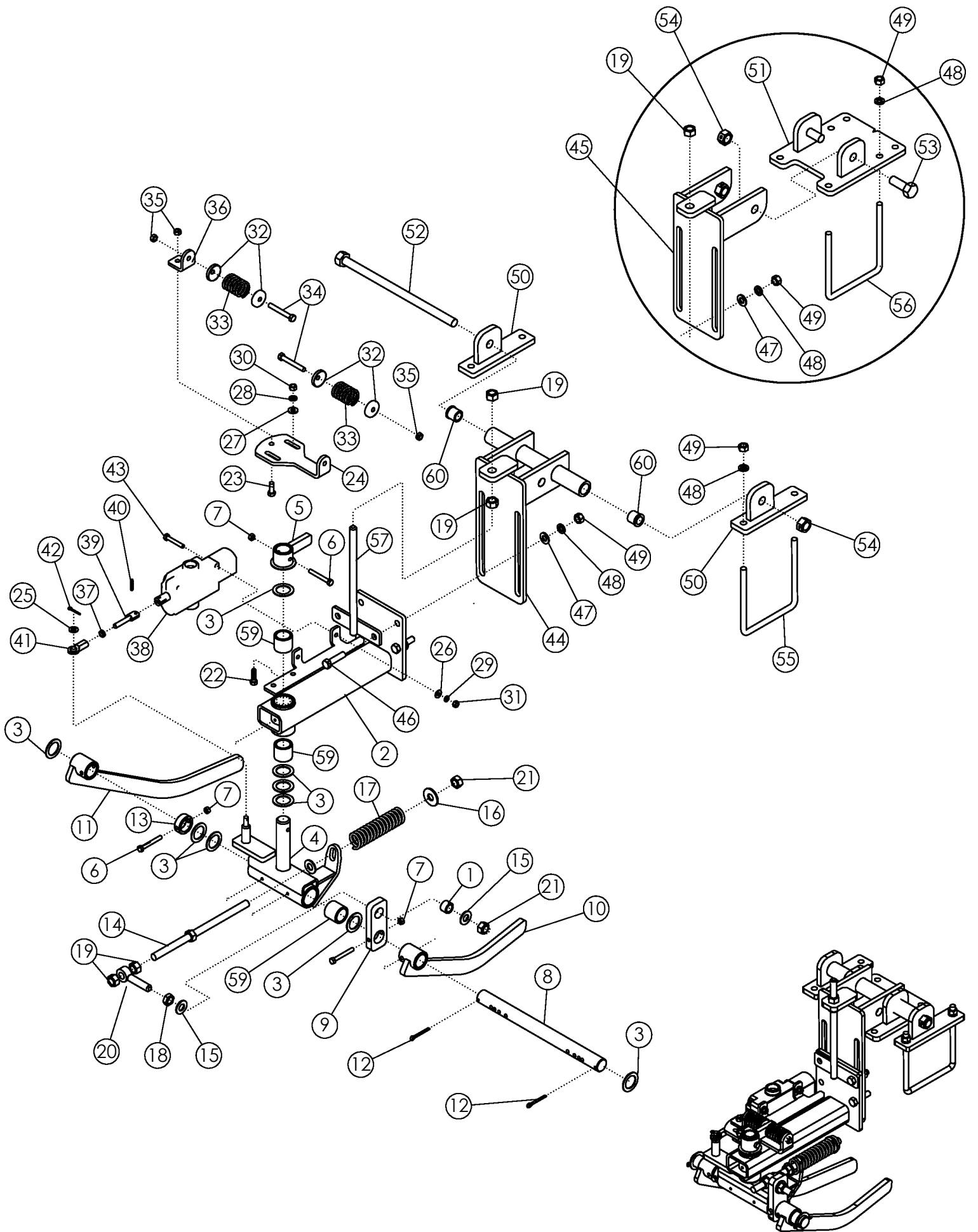

HYDRUALIC ROW FINDER

ITEM	PART NO.	DESCRIPTION	QTY
1	52567	BUSHING-ZP	1
2	62520	ASSY-ROW FINDER MAIN FRAME W/BUSHINGS	1
3	55206	BUSHING-MACH: 1.25 NR 14GA	9
4	51139	ASSY-WLDMT-SWVEL W/BUSHINGS	1
5	51130	WLDMT-FLIPPER	1
6	301748	BOLT-HEX: .31 X 2.50 NC GR8 ZP	5
7	301749	NUT-TOPLOCK: .31 NC GR8 ZP	5
8	51690	SHAFT ZP	1
9	52566	TENSIONER ARM	1
10	51131	SENSOR ARM-L.H.	1
	301055	WLDMT-SENSOR ARM LH BENT	
11	52564	SENSOR ARM-R.H.	1
	301056	WLDMT-SENSOR ARM RH BENT	
12	1030797	PIN-COTTER: .19 X 1.75 NP	2
13	51137	COLLAR	1
14	52565	ADJUSTMENT BOLT	1
15	1013004	WASHER-FLAT: SAE .63 ZP	3
16	1013024	WASHER-FLAT: .63 ZP	2
17	51692	SPRING: .21 X 1.44 OD X 6.00 15 COILS	1
18	1026259	NUT-JAM: .63 NC GR2 ZP	3
19	1011578	NUT-HEX: .63 NC GR2 ZP	3
20	51691	EYEBOLT: .63 X 3.25 ZP	1
21	1016595	NUT-TOPLOCK: .63 NC GR5 ZP	2
22	1011601	BOLT-HEX: .38 X 1.25 NC GR5 ZP	2
23	1011600	BOLT-HEX: .38 X 1.00 NC GR5 ZP	1
24	51129	PLATE-ADJUSTMENT	4
25	1014608	WASHER-FLT: SAE .38 ZP	1
26	1020416	WASHER-FLAT: .25 ZP	2
27	1011583	WASHER-FLAT: .31 ZP	2
28	1011586	WASHER-LOCK: .38 ZP	2
29	1029115	WASHER-LOCK: .31 ZP	2
30	1011576	NUT-HEX: .38 NC GR2 ZP	2
31	1011575	NUT-HEX: .31 NC GR2 ZP	2
32	52582	SPRING CAP	4
33	51689	SPRING-ROW FINDER PAINTED	2
34	1019828	BOLT-HEX: .38 X 2.75 NC GR5 ZP	2
35	1016999	NUT-TOPLOCK: .38 NC GR5 ZP	7
36	51128	SPRING PLATE	1
37	1030792	NUT-JAM: .38 NF GR2 ZP	1
38	301150	VALVE-ROWFINDER O/C	1
39	301750	WLDMT-STUD RF LONG ZP	1
40	64157	PIN-ROLL: .19 X 1.125 ZP	1

CONTINUED

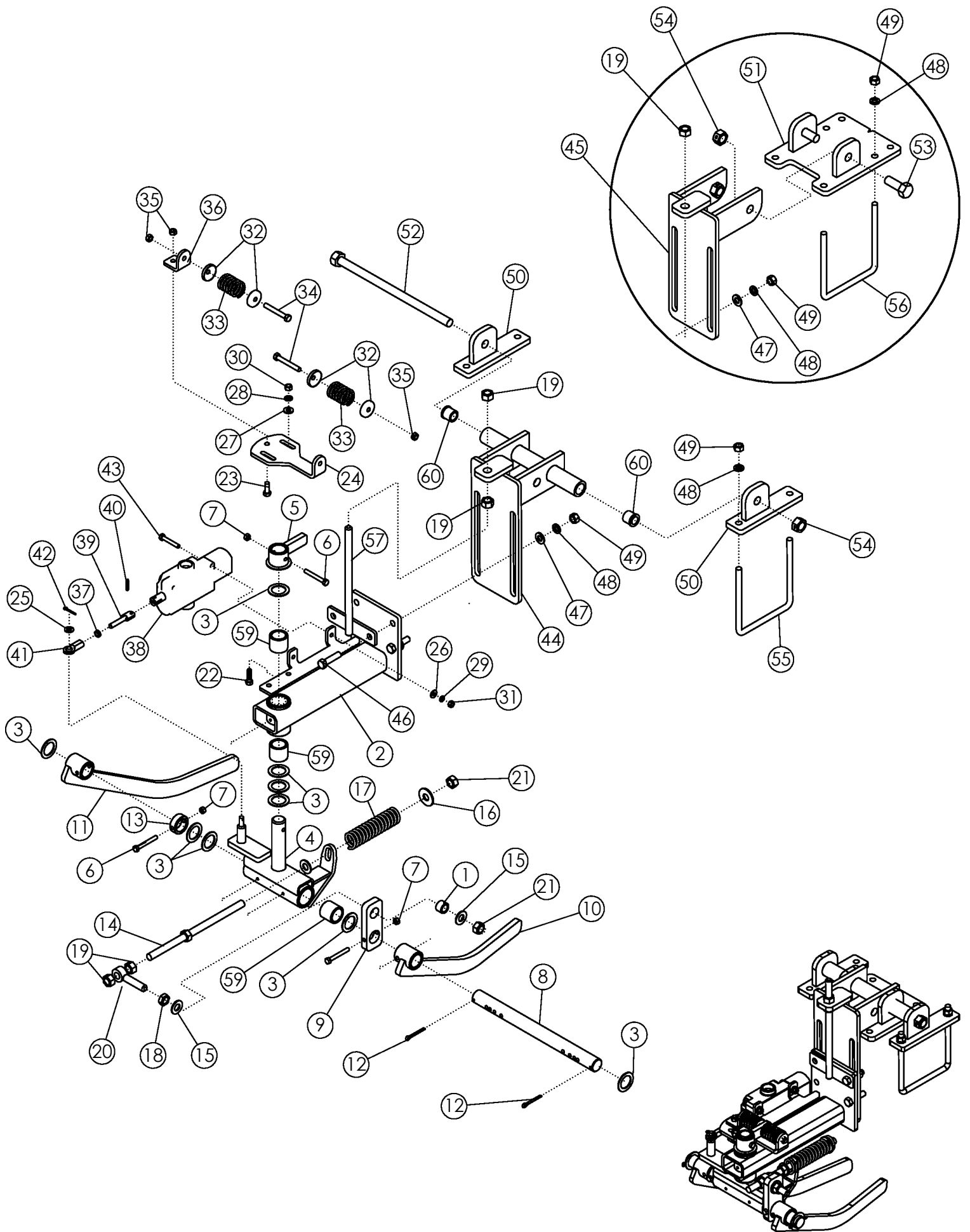

HYDRAULIC ROW FINDER (CONTINUED)

ITEM	PART NO.	DESCRIPTION	QTY
41	51136	UNIBALL COUPLING	1
42	1029137	PIN-COTTER: .13 X 1.00 ZP	1
43	1011285	BOLT-HEX: .31 X 2.00 NC	2
44	63661	WLDMT-MOUNTING BRACKET	1
45	52181	WLDMT-BRACKET	
46	1011609	BOLT-HEX: .50 X 2.00 NC GR5 ZP	4
47	1011584	WASHER-FLAT: SAE .50 ZP	4
48	1011581	WASHER-LOCK: .50 ZP	8
49	1011577	NUT-HEX: .50 NC GR2 ZP	12
50	63662	WLDMT-MOUNTING SUPPORT	2
51	301662	WLDMT-ROW FINDER BRACKET UNIVERSAL	1
52	63664	BOLT-HEX: .75 X 14.00 NC GR5 ZP	1
53	1012060	BOLT-HEX: .75 X 2.00 NC GR5 ZP	2
54	1013537	NUT-TOPLOCK: .75 NC GR5 ZP	2
55	53984	U-BOLT: .500 X 7.00 X 6.00 X 7.00	2
56	35780	U-BOLT: .500 X 7.50 X 8.00 X 7.50 ZP	
57	62882	WLDMT-TIGHTENER 11.125" ZP	1
58	1011748	ZERK - GREASE	3
59	56939	BUSHING-OILITE:1.25 X 1.625 X 1.50L	4
60	52654	BUSHING	2

54	33162	U-BOLT: .375 X 3 X 2 X 3	1
55	1013519	NUT-JAM: .38 NC GR2 ZP	11
56	302247	PLATE-APRON MOUNT	1
57	1016362	BOLT-CRG: .38 X 1.25 NC GR5 ZP	3

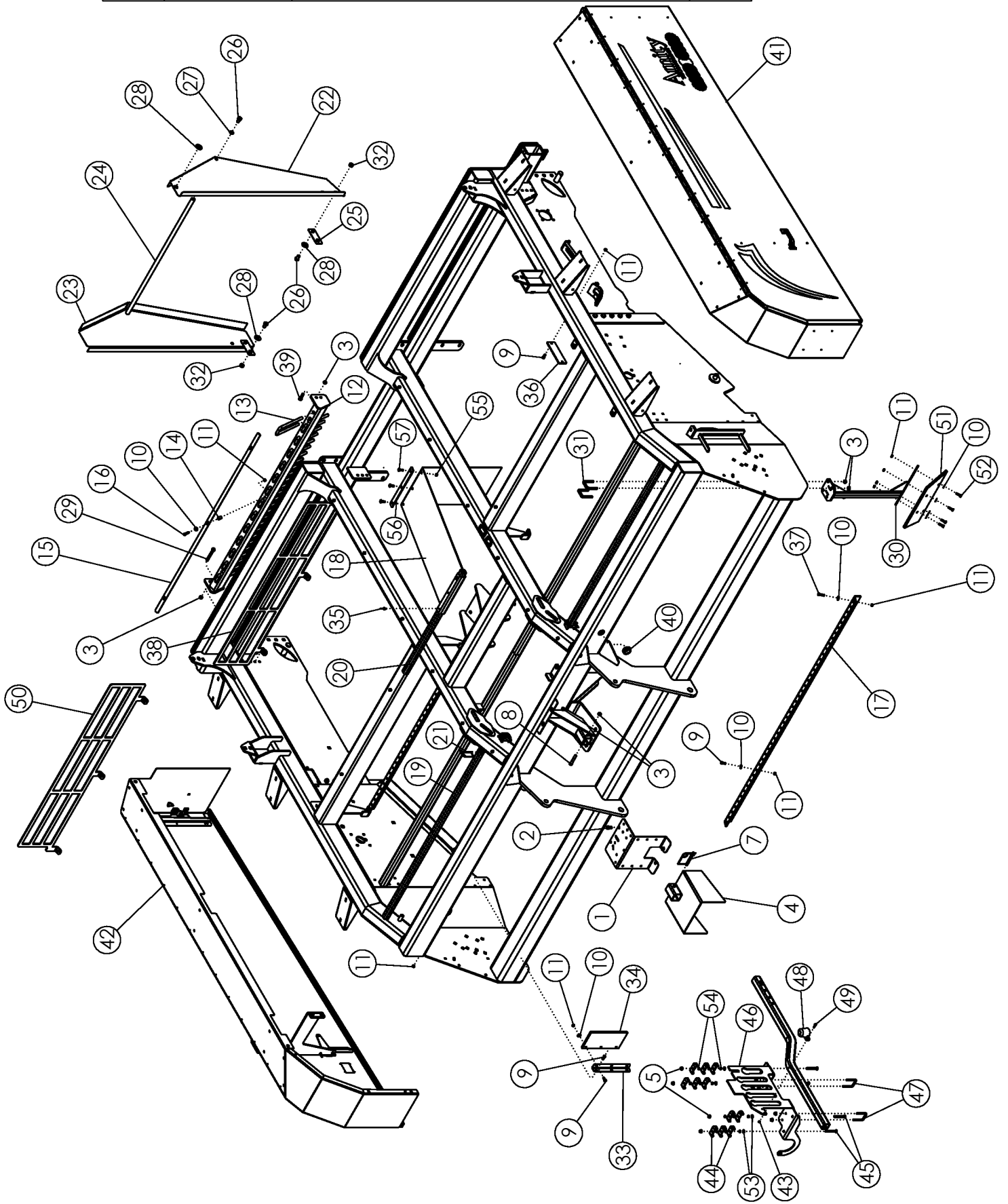

GUARDS AND SHIELDS

ITEM	PART NO.	DESCRIPTION	QTY
1	62883	PLATE-HOSE MOUNT	1
2	1011096	BOLT-HEX: .50 X 1.00 NC GR5 ZP	4
3	1027461	NUT-TOPLOCK: .50 NC GR5 ZP	41
4	63354	WLDMT-PTO SHIELD	1
5	301135	TUBE-HYD HOSE HOLDER PC	1
6	303731	NUT-FLANGE: TOPLOCK .38 NC YZP	1
7	52408	SPRING PIN .50" X 3.50"	1
8	1011611	BOLT-HEX: .50 X 3.00 NC GR5 ZP	1
9	1011600	BOLT-HEX: .38 X 1.00 NC GR5 ZP	40
10	1011828	WASHER-FLAT: .38 ZP	52
11	1016999	NUT-TOPLOCK: .38 NC GR5 ZP	65
12	58182	WLDMT-MOUNT	2
13	69117	U ROD ZP	28
14	58446	SPACER ZP	6
15	58448	STRAP	2
16	1011603	BOLT-HEX: .38 X 1.75 NC GR5 ZP	6
17	51225	MOUNT-TARP 8R	2
18	58961	APRON-RUBBER	8
19	58184	TUBE-OUTER APRON MOUNT 8R	2
20	57721	TUBE-INNER APRON 6R/8R	1
21	59101	SPRING PIN .38" X 3.00"	3
22	56257	GUARD-REAR SCRUB LH (G1 SCRUB ONLY)	1
23	56258	GUARD-REAR SCRUB RH (G1 SCRUB ONLY)	1
24	56754	PIPE-THREADED	1
25	56256	LINK-GUARD	2
26	1032275	BOLT-HEX: .63 X 1.00 NC GR5 ZP	6
27	1011813	WASHER-LOCK: .63 ZP	2
28	1013024	WASHER-FLAT: .63 ZP	4
29	1032507	BOLT-HEX: .50 X 4.00 NC GR5 ZP	4
30	62378	WLDMT - DEFLECTOR	7
31	65658	U-BOLT: .50 X 3 X 2.06 X 3	14
32	1016595	NUT-TOPLOCK: .63 NC GR5 ZP	4
33	51331	ANGLE	2
34	51680	DEFLECTOR-RUBBER	2
35	1011974	RIVET-POP: .19 X .53 ZP	24
36	63501	PLATE-COVER	2
37	1011602	BOLT-HEX: .38 X 1.50 NC GR5 ZP	4

CONTINUED

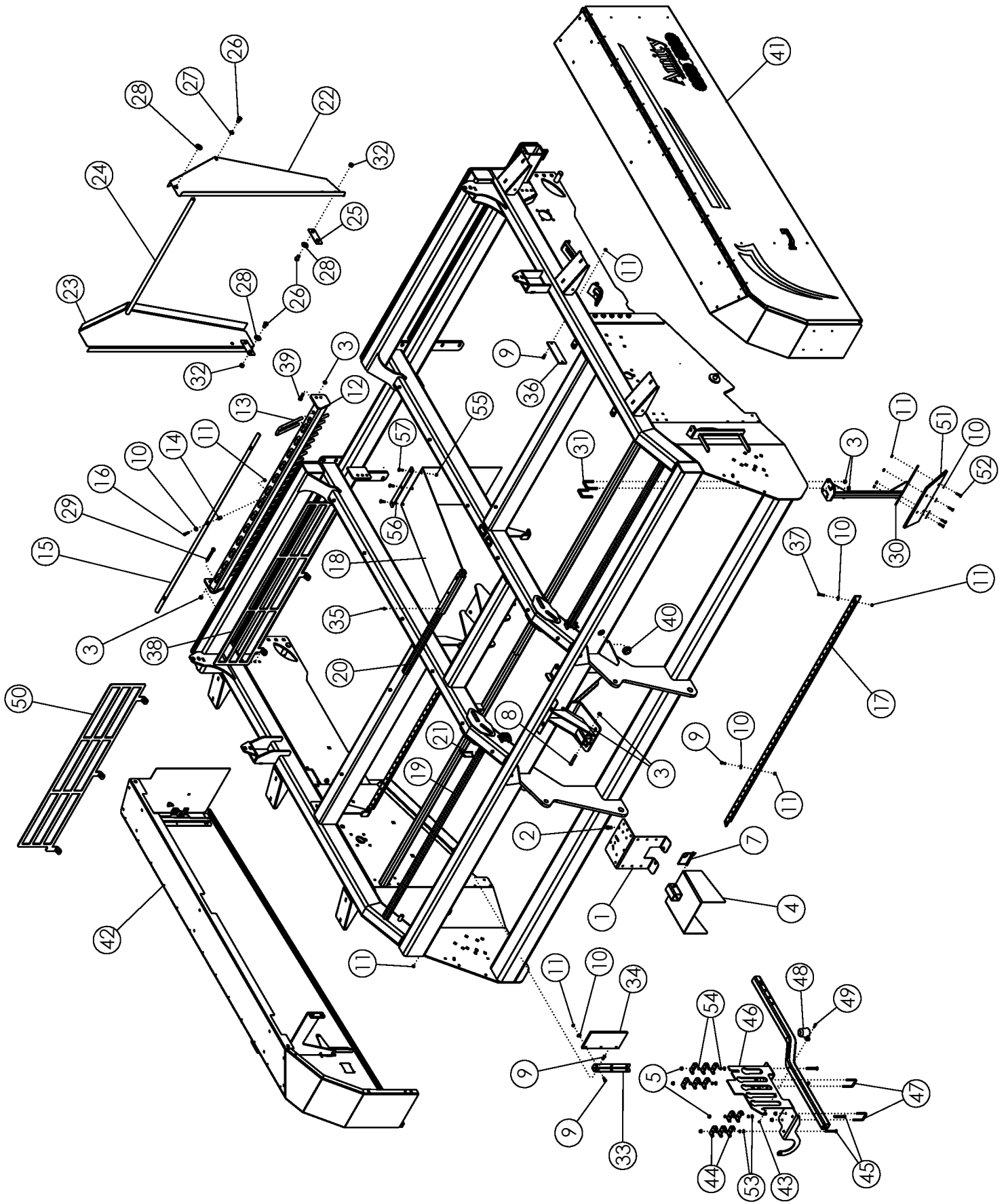

GUARDS AND SHIELDS (CONTINUED)

ITEM	PART NO.	DESCRIPTION	QTY
38	69432	PLATE-GUARD RH 8R	1
39	1011608	BOLT-HEX: .50 X 1.75 NC GR5 ZP	4
40	301025	GROMMET-RUBBER 1.50" ID	1
41	69265	ASSY-LH DOOR	1
42	69350	ASSY-RH DOOR	1
43	1030946	NUT-TOPLOCK: .25 NC GR5 ZP	2
44	50714	CLAMP 1/2" ZP	12
45	1030880	BOLT-CRG: .38 X 3.50 NC GR5 ZP	4
46	303797	PLATE-HYD HOSE HOLDER W/ PTO CATCH	1
47	33162	U-BOLT: .375 X 3 X 2 X 3	2
48	223329	HOLDER-LIGHT PLUG	1
49	1013423	BOLT-HEX: .25 X 1.00 NC GR5 ZP	2
50	69431	PLATE-GUARD LH 8R	1
51	51687	1022245 DEFLECTOR-RUBBER	7
52	1011601	BOLT-HEX: .38 X 1.25 NC GR5 ZP	4
53	1014608	WASHER-FLAT: SAE .38 ZP	4
54	1013519	NUT-JAM: .38 NC GR2 ZP	12
55	1016999	NUT-TOPLOCK: .38 NC GR5 ZP	24
56	302247	PLATE-APRON MOUNT	8
57	1016362	BOLT-CRG: .38 X 1.25 NC GR5 ZP	24

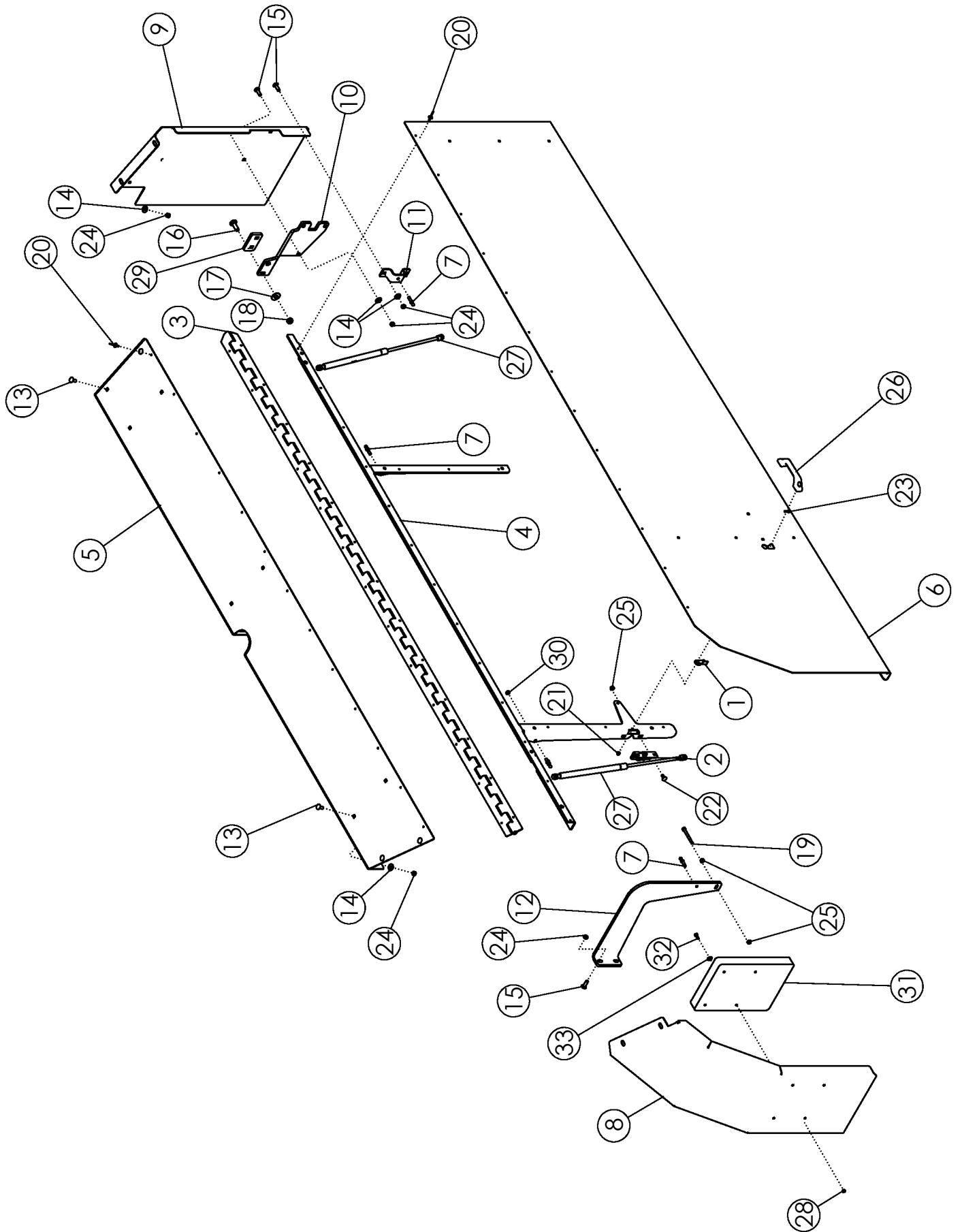

DOOR ASSEMBLY

ITEM	PART NO.	DESCRIPTION	QTY
1	69284	LEVER-HRV LATCH ZP	1
2	69283	LATCH-ROTARY	1
3	69286	HINGE-108 HEAVY CONTINUOUS	1
4	69266	VLDMT-DOOR FRAME LH	1
	69348	VLDMT-DOOR FRAME RH (NOT SHOWN)	1
5	69312	PANEL-SHIELD TOP LH PC	1
	69372	PANEL-SHIELD TOP RH PC (NOT SHOWN)	1
6	69270	SHEET-SHIELD DOOR LH PC	1
	69319	SHEET-SHIELD DOOR RH PC (NOT SHOWN)	1
7	69278	STUD-BALL .31-18NC X .75	4
8	69272	PANEL-SHIELD FRONT LH PC	1
	69317	PANEL-SHIELD FRONT RH PC (NOT SHOWN)	1
9	69273	PANEL-SHIELD REAR LH PC	1
	69318	PANEL-SHIELD REAR RH PC (NOT SHOWN)	1
10	69274	PLATE-SUPPORT REAR LH	1
	69344	PLATE-SUPPORT REAR RH (NOT SHOWN)	1
11	69275	BRACKET-SPRING REAR	1
12	69277	BRACKET-SPRING FRONT LH	1
	69320	BRACKET-SPRING FRONT RH (NOT SHOWN)	1
13	59488	BOLT-CRG: .38 X 1.00 NC GR5 ZP	10
14	1011828	WASHER-FLAT .38 ZP	17
15	1016362	BOLT-CRG: .38 X 1.25 NC GR5 ZP	7
16	1011660	BOLT-CRG: .50 X 1.50 NC GR5 ZP	2
17	1014443	WASHER-FLAT: .50 ZP	2
18	1027461	NUT-TOPLOCK: .50 NC GR5 ZP	2
19	1029448	BOLT-HEX .31 X 3.00 NC GR5 ZP	1
20	1011974	RIVET-POP: .19 X .531 ZP	32
21	1026591	NUT-K-LOCK: #10-24 GR2 ZP	2
22	65702	BOLT-CRG: .31 X .75 NC GR5 ZP	2
23	67078	SCREW-P-H: 10-24 X .75 NC GR2 ZP	2
24	1016999	NUT-TOPLOCK: .38 NC GR5 ZP	17
25	67077	NUT-FLANGE SERR .31 NC ZP GR2	4
26	69285	HANDLE-MOLDED GRAB	1
27	69282	SPRING-700N GAS	2
28	1030946	NUT-TOPLOCK: .25 NC GR5 ZP	4
29	69373	PLATE-SPACER	1
30	1030700	NUT-TOPLOCK: .31 NC GR5 ZP	4
31	64635	CASE-MANUAL STORAGE	1
32	1011595	BOLT-HEX: .25 X .75 NC GR5 ZP	4
33	1020416	WASHER-FLAT: .25 ZP	4

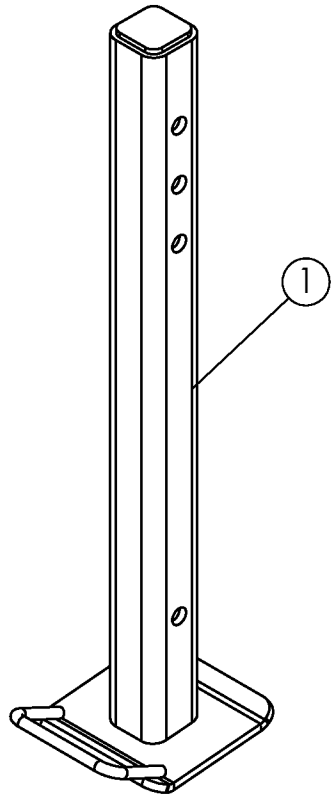
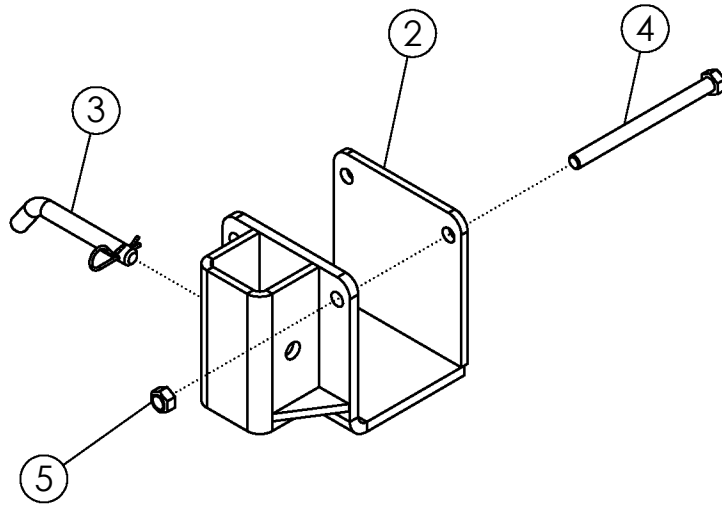

HARVESTER STAND #63397

ITEM	PART NO.	DESCRIPTION	QTY
1	63382	WLDMT-STAND SUPPORT	1
2	63377	WLDMT-STAND MOUNT	1
3	63407	PIN-BENT	1
4	1018957	BOLT-HEX: .63 X 8.00 NC GR5 ZP	2
5	1016595	NUT-TOPLOCK: .63 NC GR5 ZP	2

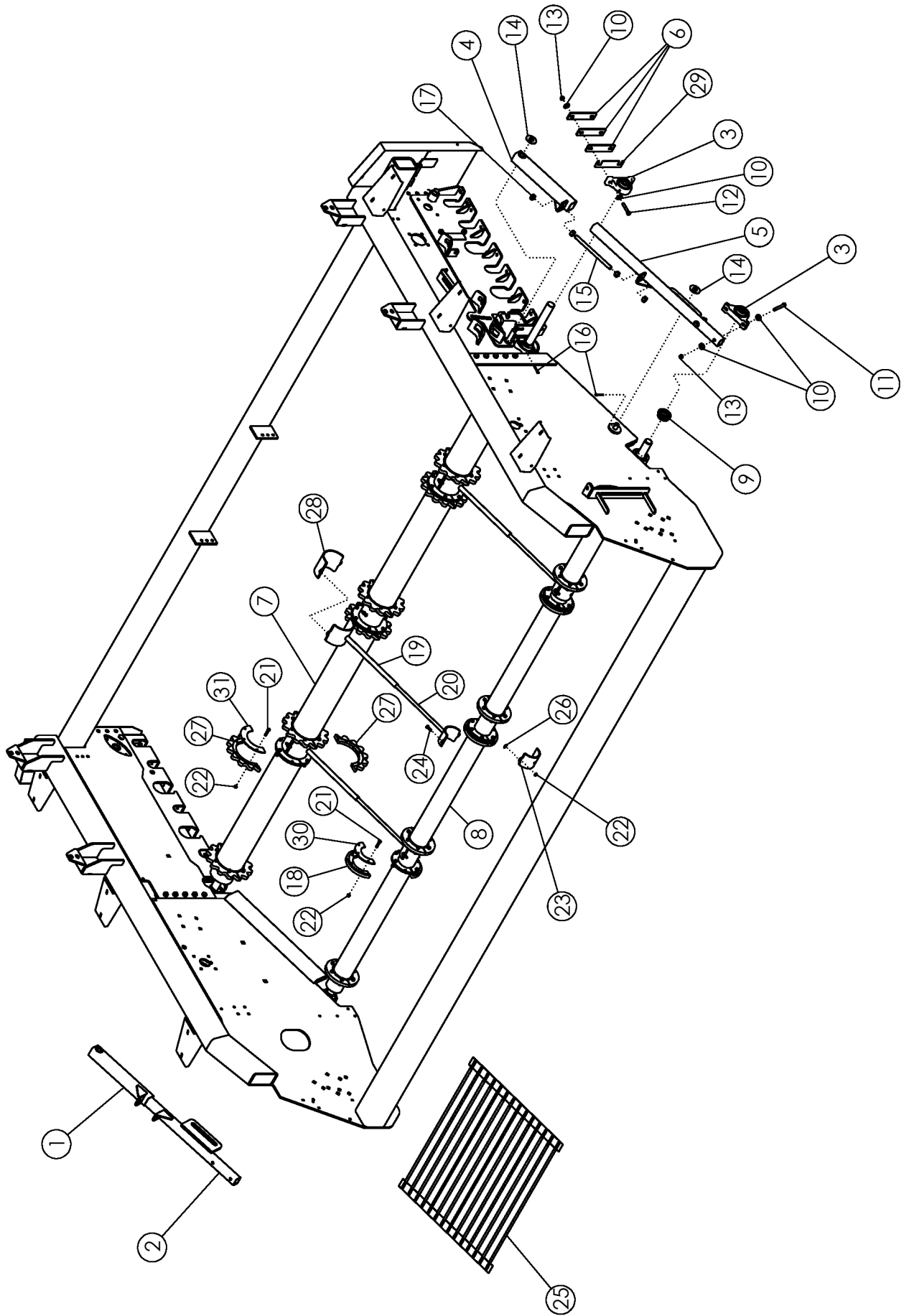

APRON SHAFT - BELTED CHAIN

ITEM	PART NO.	Description	QTY
1	56693	WLDMT-ARM RH	1
2	56698	WLDMT-SLIDE RH	1
3	52405	BEARING-PILLOW 1.75	4
4	56692	WLDMT-ARM LH	1
5	56697	WLDMT-SLIDE LH	1
6	56672	SHIM-BEARING ZP	AR
7	301142	WLDMT-TOP APRON SHAFT Ø5.50 6R30 56.5"	1
8	58326	WLDMT-BOTTOM APRON SHAFT	1
9	52382	SEAL PROTECTOR 1.75	2
10	1014443	WASHER-FLAT: .50 ZP	16
11	1029104	BOLT-HEX: .50 X 3.75 NC GR5 ZP	4
12	1011611	BOLT-HEX: .50 X 3.00 NC GR5 ZP	4
13	1027461	NUT-TOPLOCK: .50 NC GR5 ZP	8
14	1020685	WASHER-FLAT: 1.00 ZP	4
15	56718	ROD-THREADED ZP	2
16	1016944	PIN-COTTER: .25 X 2.00 ZP	4
17	1011620	NUT-HEX: .75 NC GR2 ZP	8
18	63414	DISC-SPLIT COUNTERBORE (PAIR)	8
19	301240	WLDMT-UPPER FILLER 5.5" SHAFT	3
20	301531	WLDMT-LOWER FILLER 4" SHAFT WDE	3
21	1011603	BOLT-HEX: .38 X 1.75 NC GR5 ZP	96
22	1016999	NUT-TOPLOCK: .38 NC GR5 ZP	108
23	301533	CLAMP-FILLER 4" SHAFT WDE PAINTED	3
24	64991	BOLT-HEX: .38 X 1.25 NC GR8 ZP	12
25	59560	BELT-56MM APRON 1/2 X 42 (48 LPR)	4
	69659	BELT-56MM APRON 5/8 X 42 (48 LPR)	
26	1011828	WASHER-FLAT: .38 ZP	12
27	301229	SPROCKET-SPLIT 56MM 5/8 ROD 14T CB 5.5" SHAFT	8
28	301241	CLAMP-FILLER 5.5" SHAFT	3
29	300146	SHIM-BEARING .120 THK	AR
30	303216	DISC-HALF WEAR PLATE 4"	12
31	303345	DISC-HALF WEAR PLATE 5.5"	12

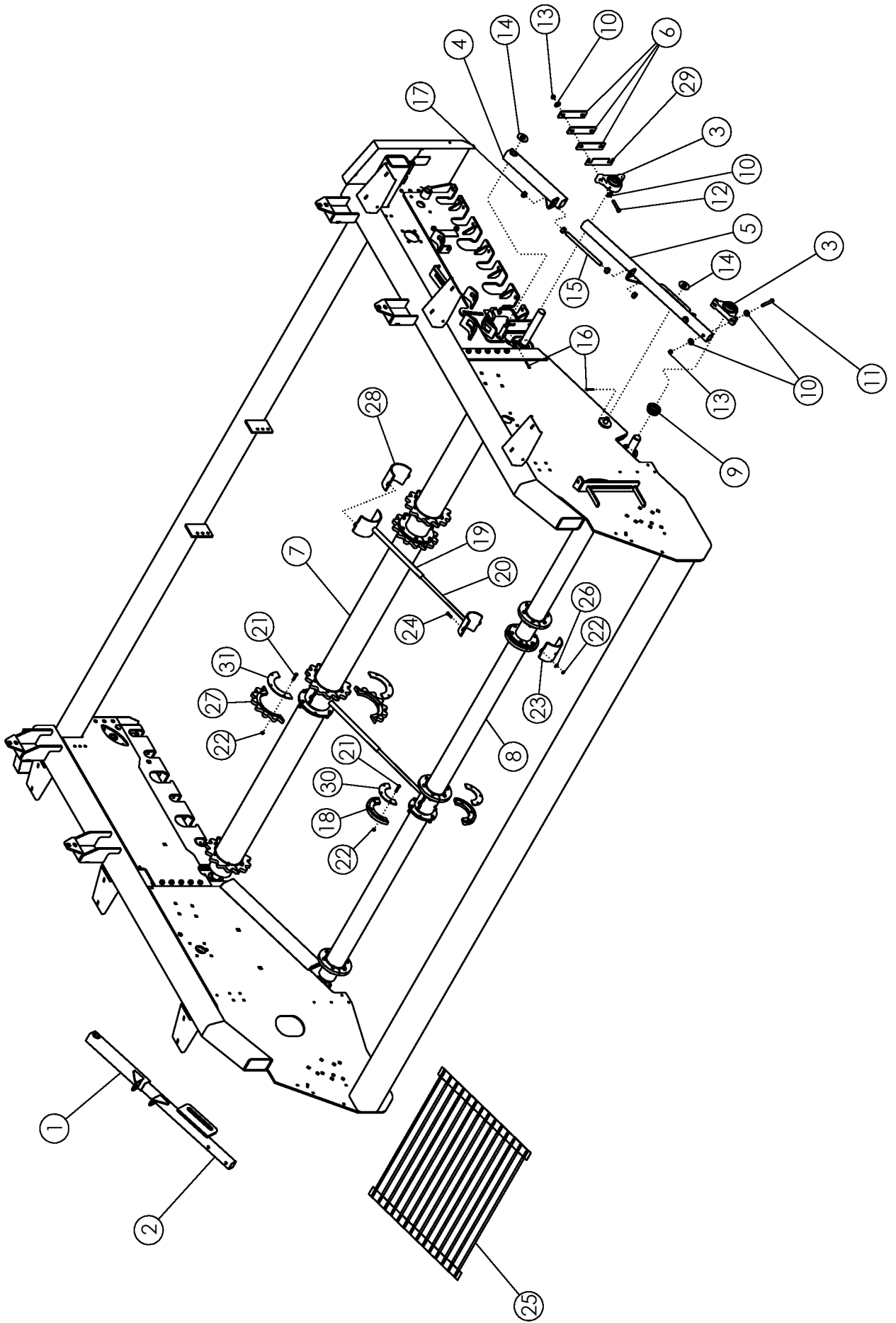

APRON SHAFT - BELTED CHAIN 6R30

ITEM	PART NO.	Description	QTY
1	56693	WLDMT-ARM RH	1
2	56698	WLDMT-SLIDE RH	1
3	52405	BEARING-PILLOW 1.75	4
4	56692	WLDMT-ARM LH	1
5	56697	WLDMT-SLIDE LH	1
6	56672	SHIM-BEARING ZP	AR
7	301228	ASSY-APRON SHAFT TOP 56MM 5/8 ROD 6R30	1
8	301230	ASSY-APRON SHAFT BOTTOM (BELT) 6R30	1
9	52382	SEAL PROTECTOR 1.75	2
10	1014443	WASHER-FLAT: .50 ZP	16
11	1029104	BOLT-HEX: .50 X 3.75 NC GR5 ZP	4
12	1011611	BOLT-HEX: .50 X 3.00 NC GR5 ZP	4
13	1027461	NUT-TOPLOCK: .50 NC GR5 ZP	8
14	1020685	WASHER-FLAT: 1.00 ZP	4
15	56718	ROD-THREADED ZP	2
16	1016944	PIN-COTTER: .25 X 2.00 ZP	4
17	1011620	NUT-HEX: .75 NC GR2 ZP	8
18	63414	DISC-SPLIT COUNTERBORE (PAIR)	6
19	301240	WLDMT-UPPER FILLER 5.5" SHAFT	2
20	301531	WLDMT-LOWER FILLER 4" SHAFT WDE	2
21	1011603	BOLT-HEX: .38 X 1.75 NC GR5 ZP	72
22	1016999	NUT-TOPLOCK: .38 NC GR5 ZP	84
23	301533	CLAMP-FILLER 4" SHAFT WDE PAINTED	2
24	64991	BOLT-HEX: .38 X 1.25 NC GR8 ZP	8
25	64904	BELT-56MM APRON 5/8 X 56.5" (48 LPR)	3
26	1011828	WASHER-FLAT: .38 ZP	8
27	301229	SPROCKET-SPLIT 56MM 5/8 ROD 14T CB 5.5" SHAFT	12
28	301241	CLAMP-FILLER 5.5" SHAFT	2
29	300146	SHIM-BEARING .120 THK	AR
30	303216	DISC-HALF WEAR PLATE 4"	8
31	303345	DISC-HALF WEAR PLATE 5.5"	8

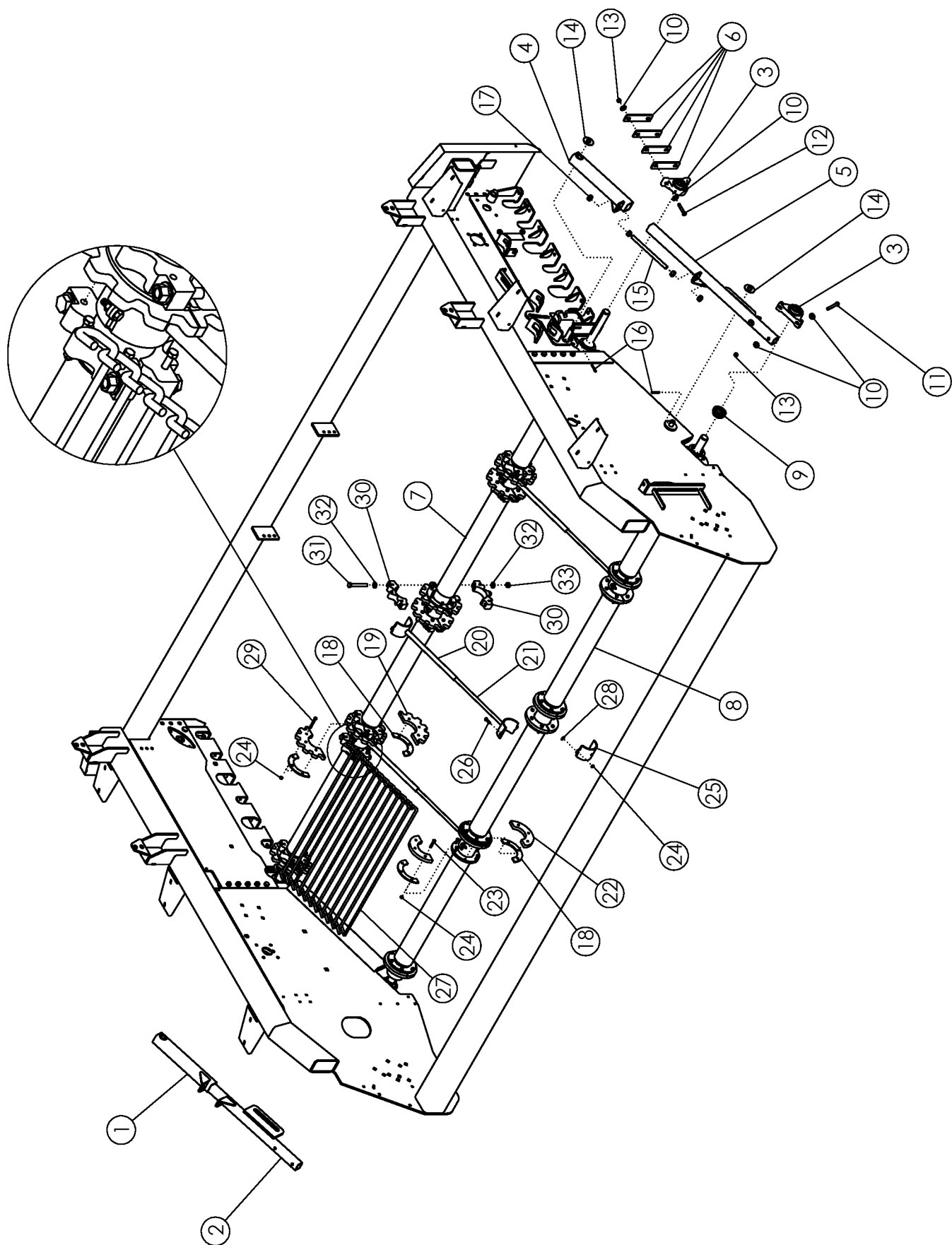

APRON SHAFT - HOOK CHAIN

ITEM	PART NO.		QTY
1	56693	WLDMT-ARM RH	1
2	56698	WLDMT-SLIDE RH	1
3	52405	BEARING-PILLOW 1.75	4
4	56692	WLDMT-ARM LH	1
5	56697	WLDMT-SLIDE LH	1
6	56672	SHIM-BEARING ZP	AR
7	69262	WLDMT-TOP APRON SHAFT	1
8	58326	WLDMT-BOTTOM APRON SHAFT	1
9	52382	SEAL PROTECTOR 1.75	2
10	1014443	WASHER-FLAT: .50 ZP	16
11	1029104	BOLT-HEX: .50 X 3.75 NC GR5 ZP	4
12	1011611	BOLT-HEX: .50 X 3.00 NC GR5 ZP	4
13	1027461	NUT-TOPLOCK: .50 NC GR5 ZP	8
14	1020685	WASHER-FLAT: 1.00 ZP	4
15	56718	ROD-THREADED ZP	2
16	1016944	PIN-COTTER: .25 X 2.00 ZP	4
17	1011620	NUT-HEX: .75 NC GR2 ZP	8
18	62836	HALF DISC-SPACER ZP (1/2" CHAIN ONLY)	32
19	301221	SPROCKET-SPLIT 2.375 14T	8
	64154	SPROCKET-HALF 2.375 12T 4" SHAFT (ROCK) ZP	16
20	64162	WLDMT-UPPER FILLER	3
21	64161	WLDMT-LOWER FILLER	3
22	58322	HALF-DISC	16
23	1013239	BOLT-HEX: .38 X 3.00 NC GR5 ZP (1/2" CHAIN ONLY)	48
	1019828	BOLT-HEX: .38 X 2.75 NC GR5 ZP	
24	1016999	NUT-TOPLOCK: .38 NC GR5 ZP	108
25	64159	CLAMP-FILLER PAINTED	6
26	64991	BOLT-HEX: .38 X 1.25 NC GR8 ZP	12
27	53844	CHAIN 1/2 X 42 X 2.38	8
	53846	CHAIN 5/8 X 42 X 2.38	
28	1011828	WASHER-FLAT: .38 ZP	12
29	1011725	BOLT-HEX: .38 X 2.00 NC GR5 ZP (1/2" CHAIN ONLY)	48
	1011603	BOLT-HEX: .38 X 1.75 NC GR5 ZP	
30	69245*	CLAMP-APRON	12
31	69246*	BOLT-HEX: .63 X 4.75NC GR8 ZP	12
32	66498*	WASHER-FLAT: SAE .63 YZP GR8	24
33	66500*	NUT-HEX: .63NC GR8 ZP	12

*INCLUDED IN ITEM 7

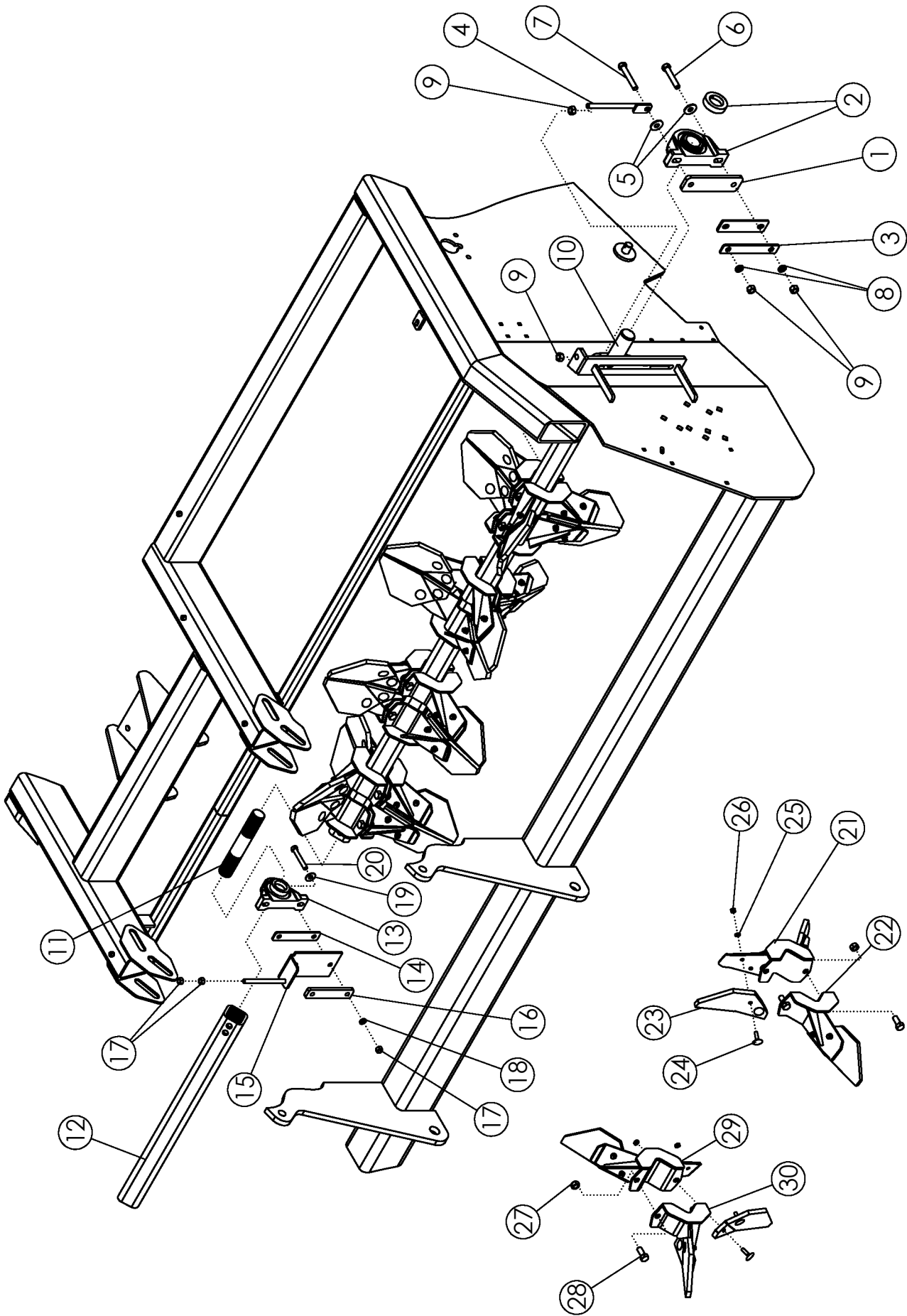

PADDLE SHAFT			
ITEM	PART NO.	DESCRIPTION	QTY
1	57996	SHIM-BEARING ZP	2
2	57997	BEARING-PILLOW 2"	2
3	57998	PLATE-BACKING ZP	2
4	51365	TIGHTENER BOLT	2
5	1013024	WASHER-FLAT: .63 ZP	4
6	1014000	BOLT-HEX: .63 X 3.50 NC GR5 ZP	2
7	1016726	BOLT-HEX: .63 X 4.00 NC GR5 ZP	2
8	1011813	WASHER-LOCK: .63 ZP	4
9	1011578	NUT-HEX: .63 NC GR2 ZP	8
10	58027	WLDMT-PADDLE SHAFT LH	1
11	57196	SHAFT-SPLINED	1
12	58028	WLDMT-PADDLE SHAFT RH	1
13	52405	BEARING-PILLOW 1-3/4"	1
14	50564	PLATE	1
15	56737	WLDMT-ROD ZP	1
16	50305	SPACER-BEARING	1
17	1011577	NUT-HEX: .50 NC GR2 ZP	4
18	1011581	WASHER-LOCK: .50 ZP	2
19	1014443	WASHER-FLAT: .50 ZP	2
20	1011612	BOLT-HEX: .50 X 3.50 GR5 ZP	2
21	50719*	WLDMT - PADDLE DOUBLE LH	1 Per Row
22	50720*	WLDMT - PADDLE SINGLE LH	1 Per Row
23	51562	PADDLE-RUBBER	48
24	1030779	BOLT-ELEVATOR: .38 X 1.50 NC ZP	96
25	1011586	WASHER-LOCK: .38 ZP	96
26	1011576	NUT-HEX: .38 NC GR2 ZP	96
27	1016595	NUT-TOPLOCK: .63 NC GR5 ZP	32
28	1014349	BOLT-HEX: .63 X 1.50 NC GR5 ZP	32
29	50722**	WLDMT - PADDLE DOUBLE RH	1 Per Row
30	50721**	WLDMT - PADDLE SINGLE RH	1 Per Row

* INCLUDED IN ASSEMBLY 64133

** INCLUDED IN ASSEMBLY 64134

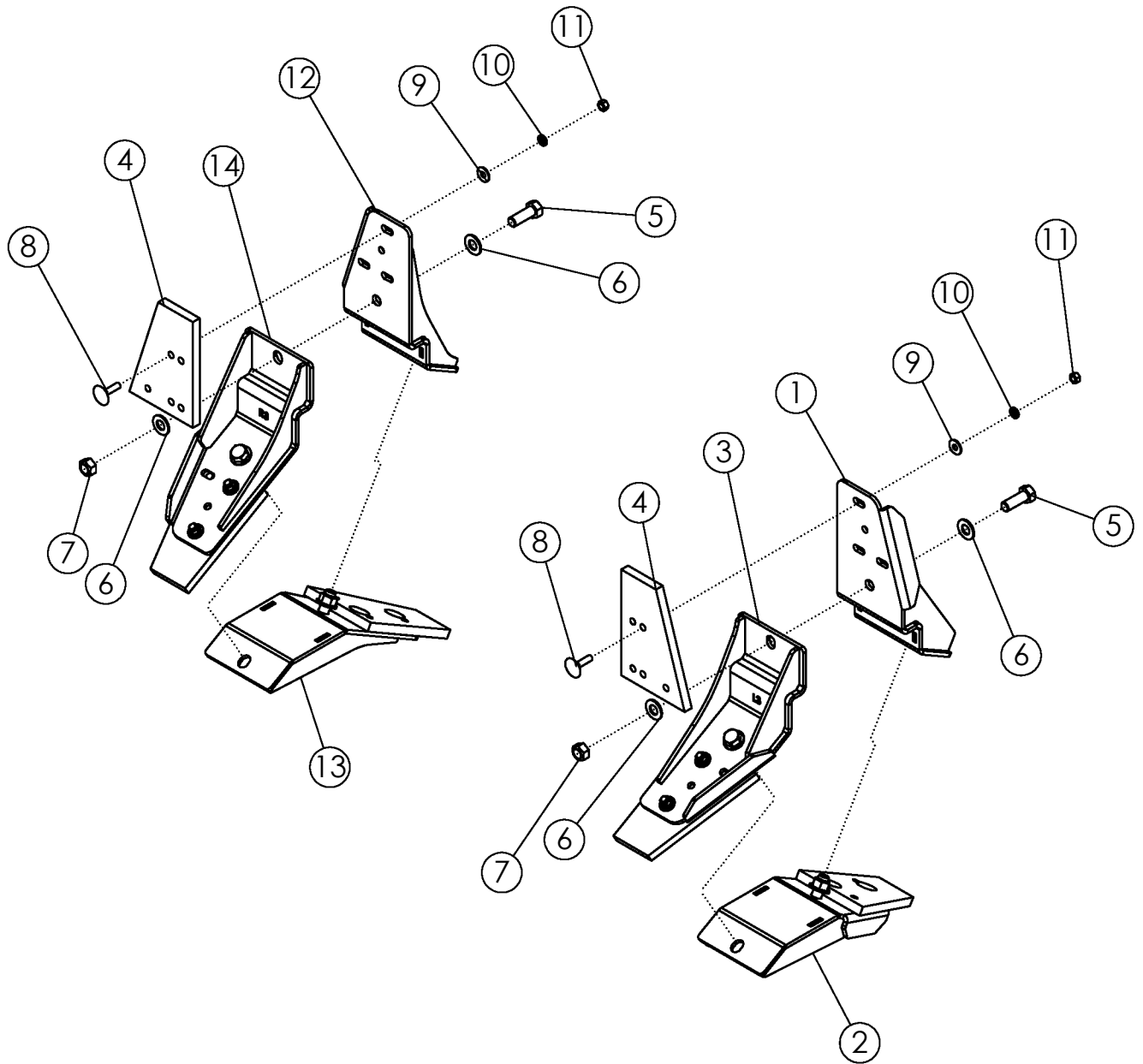

HYBRID PADDLE ASSY

ITEM	PART NO.	DESCRIPTION	QTY
1	301863*	WLDMT-PADDLE SPLIT LH 1	1
2	301867*	WLDMT-PADDLE SPLIT LH 2	1
3	301871*	WLDMT-PADDLE SPLIT LH 3	1
4	301875	PADDLE-RUBBER SOLID	6
5	1013918	BOLT-HEX .63 X 1.750 NC GR5 ZP	6
6	1013004	WASHER-FLAT : SAE.63 ZP	12
7	1016595	NUT-TOPLOCK: .63 NC GR5 ZP	6
8	1030779	BOLT-ELEVATOR: .38 X 1.50 NC ZP	18
9	1011828	WASHER-FLAT: .38 ZP	18
10	1011586	WASHER-LOCK: .38 ZP	18
11	1011576	NUT-HEX: .38 NC GR2 ZP	18
12	301865**	WLDMT-PADDLE SPLIT RH 1	1
13	301869**	WLDMT-PADDLE SPLIT RH 2	1
14	301873**	WLDMT-PADDLE SPLIT RH 3	1

* INCLUDED IN ASSEMBLY 301862

** INCLUDED IN ASSEMBLY 301861

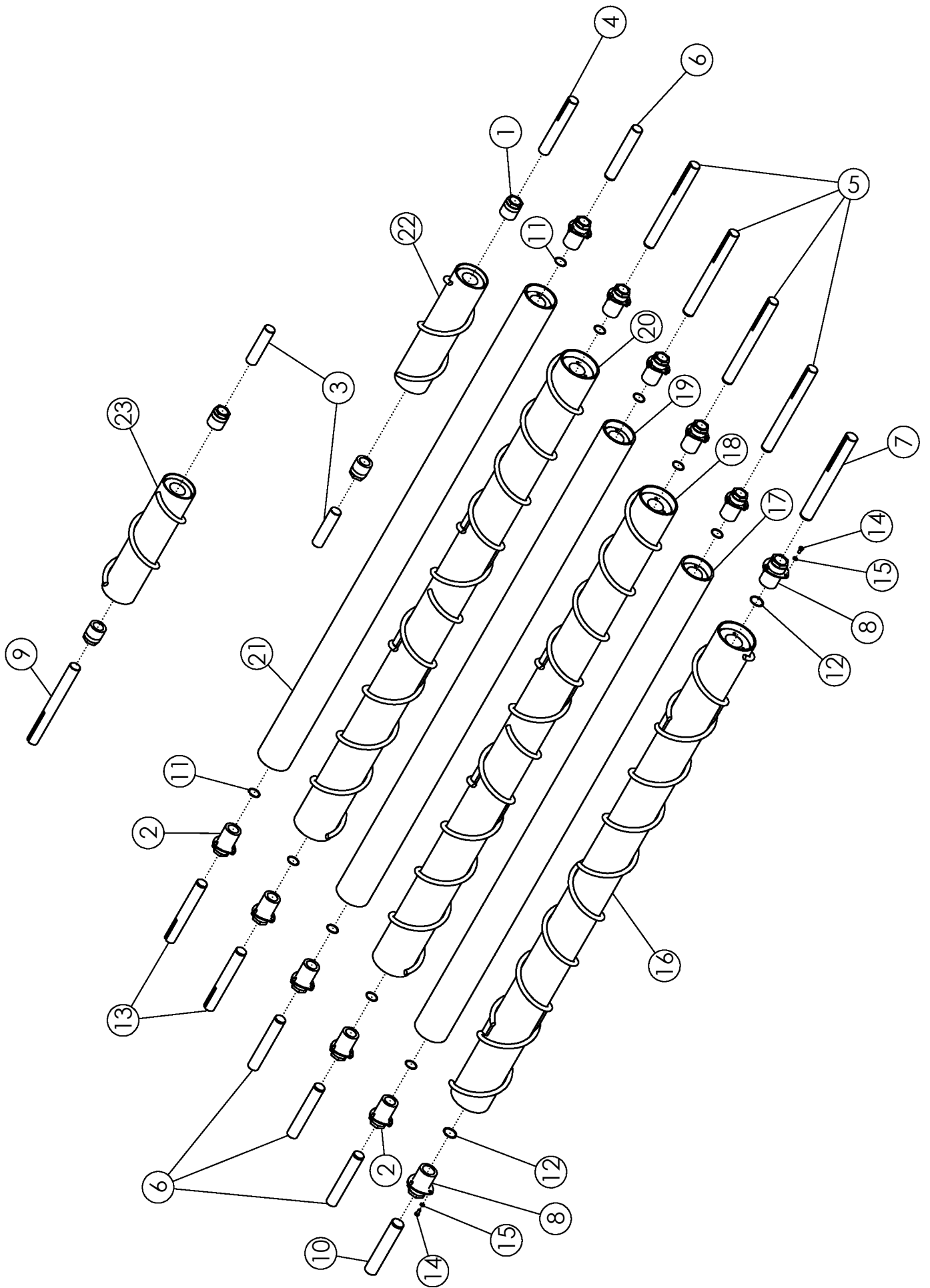

CLEANING ROLLS

ITEM	PART NO.	DESCRIPTION	QTY
PARTS COMMON TO ALL ROLLS			
1	58459	HUB-TRAN TORQUE 1.75	4
2	64163	HUB-TRAN TORQUE 1.75 X 3.38	10
3	59471	SHAFT-STUB-#7 ROLL-RH, LH-IDLER	2
4	58759	SHAFT- #2, 3, 4, 5, 7LH	1
5	64177	SHAFT-DRIVE #2,3,4,5	4
6	64179	SHAFT-IDLER #2,3,4,6	4
7	64181	SHAFT-#1 DRIVE END	1
8	64165	HUB-TRAN TORQUE 2.00 X 3.38	2
9	58761	SHAFT-#7 RH ROLL-DRIVE END	1
10	64182	SHAFT-#1 IDLER END	1
11	64184	RING-RETAINING 1.75	10
12	64185	RING-RETAINING 2.00	2
13	64178	SHAFT-#5,6	2
14	1011599	BOLT-HEX: .38 X .75 NC GR5 ZP	36
15	1011586	WASHER-LOCK: .38 ZP	36
NUMBER ONE ROLL (COMPLETE)			
16	59011	WLDMT-#1 SCROLLED-8R-POLY-TT	1
	58966	WLDMT-#1 SCROLLED-8R-HRD-TT	
	58999	WLDMT-#1 SCROLLED-8R-STD-TT	
NUMBER TWO ROLL (COMPLETE)			
17	58969	ASSY-#2-8R-5.5" STD-TT	1
	59016	ASSY-#2-8R-5" POLY-TT	
NUMBER THREE ROLL (COMPLETE)			
18	58977	WLDMT-#3 SCROLLED-8R-HRD-TT	1
	59000	WLDMT-#3 SCROLLED-8R-STD-TT	
	59013	WLDMT-#3 SCROLLED-8R-POLY-TT	
NUMBER FOUR ROLL (COMPLETE)			
19	62764	ASSY-#4-8R-5.5" STD-TT	1
	62765	ASSY-#4-8R-5" POLY-TT	
NUMBER FIVE ROLL (COMPLETE)			
20	302765	WLDMT-#5 SCROLLED-8R-HRD-TT	1
	302763	WLDMT-#5 SCROLLED-8R-STD-TT	
	302764	WLDMT-#5 SCROLLED-8R-POLY-TT	
NUMBER SIX ROLL (COMPLETE)			
21	58989	ASSY-#6-8R-5.5" STD-TT	1
	59017	ASSY-#6-8R-5" POLY-TT	
NUMBER SEVEN ROLL LEFT HAND (COMPLETE)			
22	302647	WLDMT-#7LH SCROLL-8R-TT-SHORT	1
	302659	WLDMT-#7LH SCROLLED POLY-8R	
NUMBER SEVEN ROLL RIGHT HAND (COMPLETE)			
23	302648	WLDMT-#7RH SCROLL-8R-TT-SHORT	1
	302660	WLDMT-#7RH SCROLLED POLY-8R	

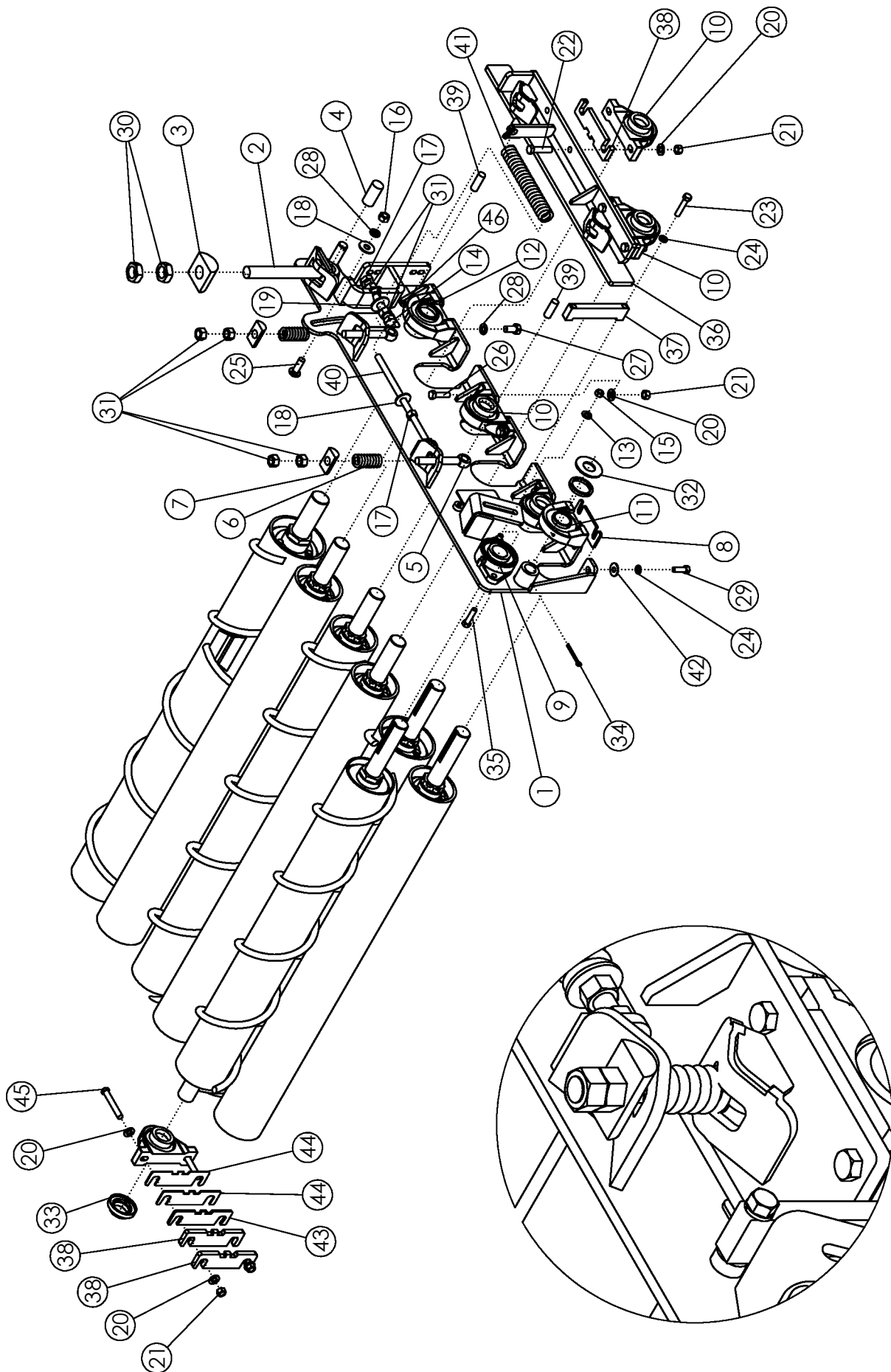

CLEANING ROLL MOUNTING PACKAGE

ITEM	PART NO.	DESCRIPTION	QTY
1	58907	WLDMT-MOUNT RH	1
	58906	WLDMT-MOUNT LH (NOT SHOWN)	1
2	56813	BOLT-EYEBOLT: 1.25 X 10.5 ZP	2
3	56679	HALF ROUND 3.0" ZP	2
4	56676	ROD ZP	2
5	56814	BOLT-EYEBOLT: .75 X 6.00 ZP	4
6	57877	SPRING 3.00" (RIGHT SIDE ONLY)	2
7	56680	HALF ROUND 1.50" ZP	4
8	57992	SHIM-BEARING	2
9	62134	BEARING-FLANGE 1-3/4"	2
10	52405	BEARING-PILLOW 1-3/4"	10
	64466	PILLOW BLOCK BEARING 1-3/4" STL (ROCK ONLY)	
11	62135	BEARING 1.750 TAPPED BASE	2
	301608	ASSY-STEEL TAPPED BASE BRG 1-3/4"(ROCK ONLY)	
12	62136	BEARING 2.000 TAPPED BASE	2
	301523	ASSY-STL TAPPED BASE BRG 2.00" (ROCK ONLY)	
13	1011584	WASHER-FLAT: SAE .50 ZP	4
14	303390	BOLT-HEX: .75 X 3.50 NC GR5 ZP FT	2
15	1027461	NUT-TOPLOCK: .50 NC GR5 ZP	4
16	1011578	NUT-HEX: .63 NC GR2 ZP	6
17	1011827	NUT-JAM: .75 NC GR2 ZP	2
18	1013024	WASHER-FLAT: .63 ZP	4
19	1030702	WASHER-FLAT: .75 ZP	4
20	59104	WASHER-FLAT: .56 GR8 ZP	24
21	59105	NUT-TOPLOCK: .56 NC GR8 ZP	20
22	59103	BOLT-HEX: .56 X 2.50 NC GR8 ZP	8
23	1011610	BOLT-HEX: .50 X 2.50 NC GR5 ZP	4
24	1011581	WASHER-LOCK: .50 ZP	8
25	58635	BOLT-CRG: .63 X 2.00 NC GR5 ZP	2
26	59102	BOLT-HEX: .56 X 2.00 NC GR8 ZP	8
27	1032509	BOLT-HEX: .63 X 1.25 NC GR5 ZP	4
28	1011813	WASHER-LOCK: .63 ZP	6
29	1011607	BOLT-HEX: .50 X 1.50 NC GR5 ZP	4
30	62511	NUT-JAM: 1.25 NC GR2 ZP	4
31	1011620	NUT-HEX: .75 NC GR2 ZP	12
32	1013431	WASHER-FLAT: 1.25 ZP	2
33	52383	LOCK PROTECTOR 1-3/4"	4
34	1016727	PIN-COTTER: .25 X 2.50 NP	2
35	1011609	BOLT-HEX: .50 X 2.00 NC GR5 ZP	4
36	56682	WLDMT-SLIDE MOUNT RH	1
	56681	WLDMT-SLIDE MOUNT LH (NOT SHOWN)	1
37	56677	WLDMT-HOLDER	2
38	57792	SHIM-BEARING	8
39	56675	ROD ZP	4
40	56815	WLDMT-BOLT & NUT ZP	2
41	57878	SPRING 10"	2
42	1014443	WASHER-FLAT: .50 ZP	4
43	56672	SHIM-BEARING 0.25" 2 X 7.5 ZP	4
44	300146	SHIM-BEARING 0.12" 2 X 7.5 ZP	2
45	302556	BOLT-HEX: .56 X 3.75 NC GR8 ZP	4
46	1015294	ZERK-GREASE: .13 NPT 90DEG	2

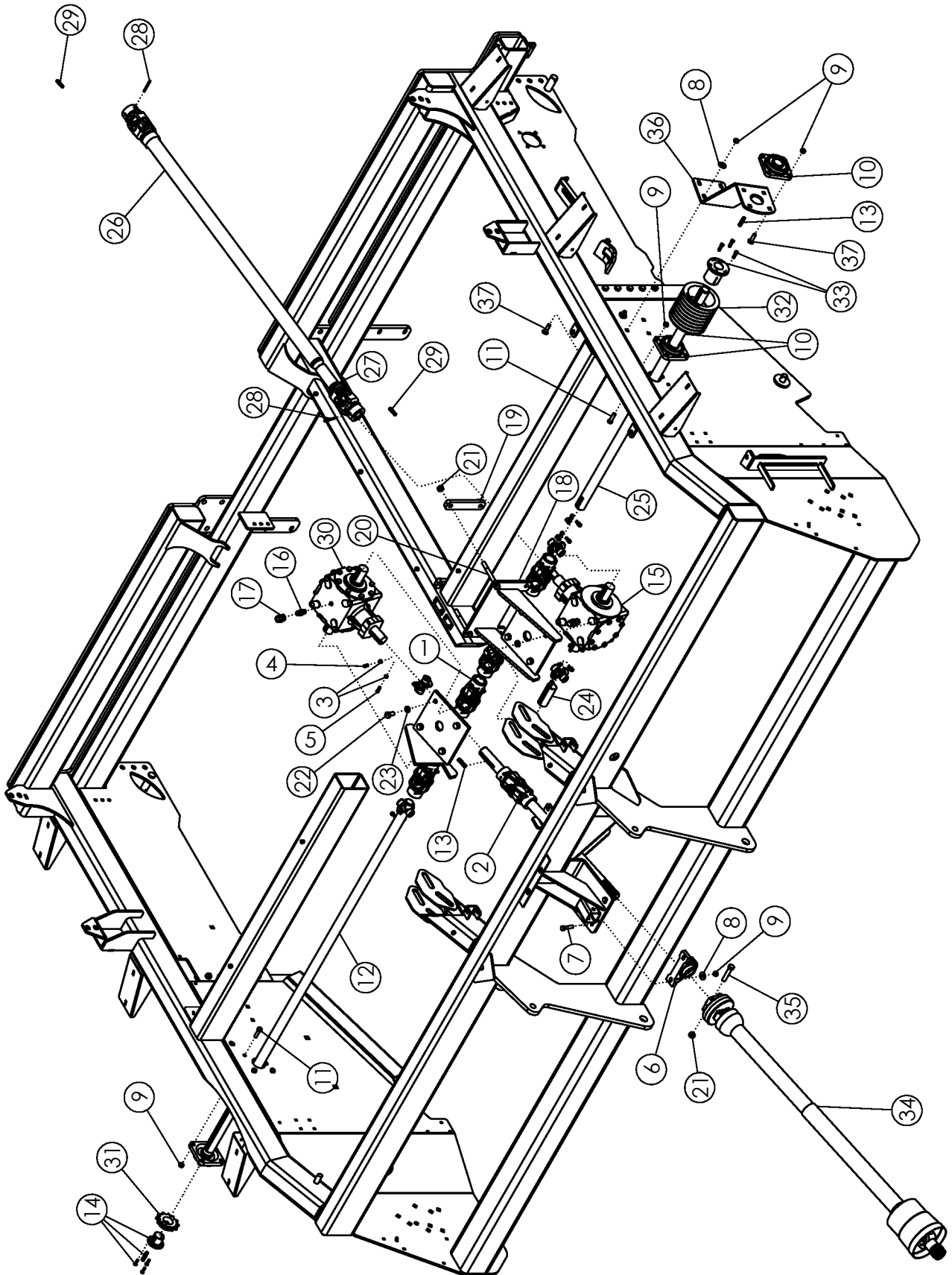

MAIN DRIVE

ITEM	PART NO.	DESCRIPTION	QTY
1	53642	U-JOINT	5
2	56775	SPLINE SHAFT	1
3	1013519	NUT-JAM: .38 NC GR2 ZP	20
4	1032511	SCREW-SET:SQ HD .38 X .75	10
5	50813	SCREW-SET: SQ HD .38 X 1.00 ZP	10
6	52405	BEARING-PILLOW 1.75	1
7	1017708	BOLT-HEX: .50 X 2.25 NC GR5 ZP	2
8	1014443	WASHER-FLAT: .50 ZP	6
9	1027461	NUT-TOPLOCK: .50 NC GR5 ZP	18
10	52404	BEARING-FLANGE 1.75	2
11	1011608	BOLT-HEX: .50 X 1.75 NC GR5 ZP	8
12	56759	SHAFT-DRIVE 8R	1
13	50152	KEY .38 X .38 X 2.00	11
14	53641	HUB P1 1.75 (WITH KEY)	1
15	63847	GEARBOX-PRAIRIE (1.35:1) BLACK	1
16	69128	FTG-ADAPTER: 8MP-8MP 4" LONG	2
17	55730	FTG-ADAPTER: 8FP-8FP	2
18	62204	WLDMT - MOUNT GEARBOX	1
19	62544	BAR - BOLTING	2
20	1032504	BOLT-HEX: .63 X 6.00 NC GR8 ZP	4
21	1016595	NUT-TOPLOCK: .63 NC GR5 ZP	6
22	1032509	BOLT-HEX: .63 X 1.25 NC GR5 ZP	8
23	1011813	WASHER-LOCK: .63 ZP	8
24	57934	SHAFT-DRIVE LH SHORT	1
25	58336	SHAFT-DRIVE LH LONG	1
26	57924	SHAFT-DRIVE: 72.50	1
27	57925	COUPLER-DRIVE BLACK	1
28	58489	PIN-ROLL: .25 X 2.75 NP	2
29	58396	KEY .31 X .31 X 1.75	2
30	63848	GEARBOX-PRAIRIE (1:1.35) 6001 (BLACK)	1
31	62034	SPROCKET H80-P12	1
32	57680	SHEAVE 8B62Q	1
	57681	SHEAVE 8B68Q	
	57679	SHEAVE 8B56Q	
33	55123	HUB Q2 1.75	1
34	301575	PTO-CV 1 3/8"-21 X 90" WEASLER (HRV)	1
	301558	PTO-CV 1 3/4"-20 X 90" WEASLER (HRV)	
35	1030704	BOLT-HEX: .63 X 3.25 NC GR5 ZP	2
36	68111	BRACKET-BRACE BEARING	1
37	59517	BOLT-CRG: .50 X 1.75 NC GR5 ZP	8

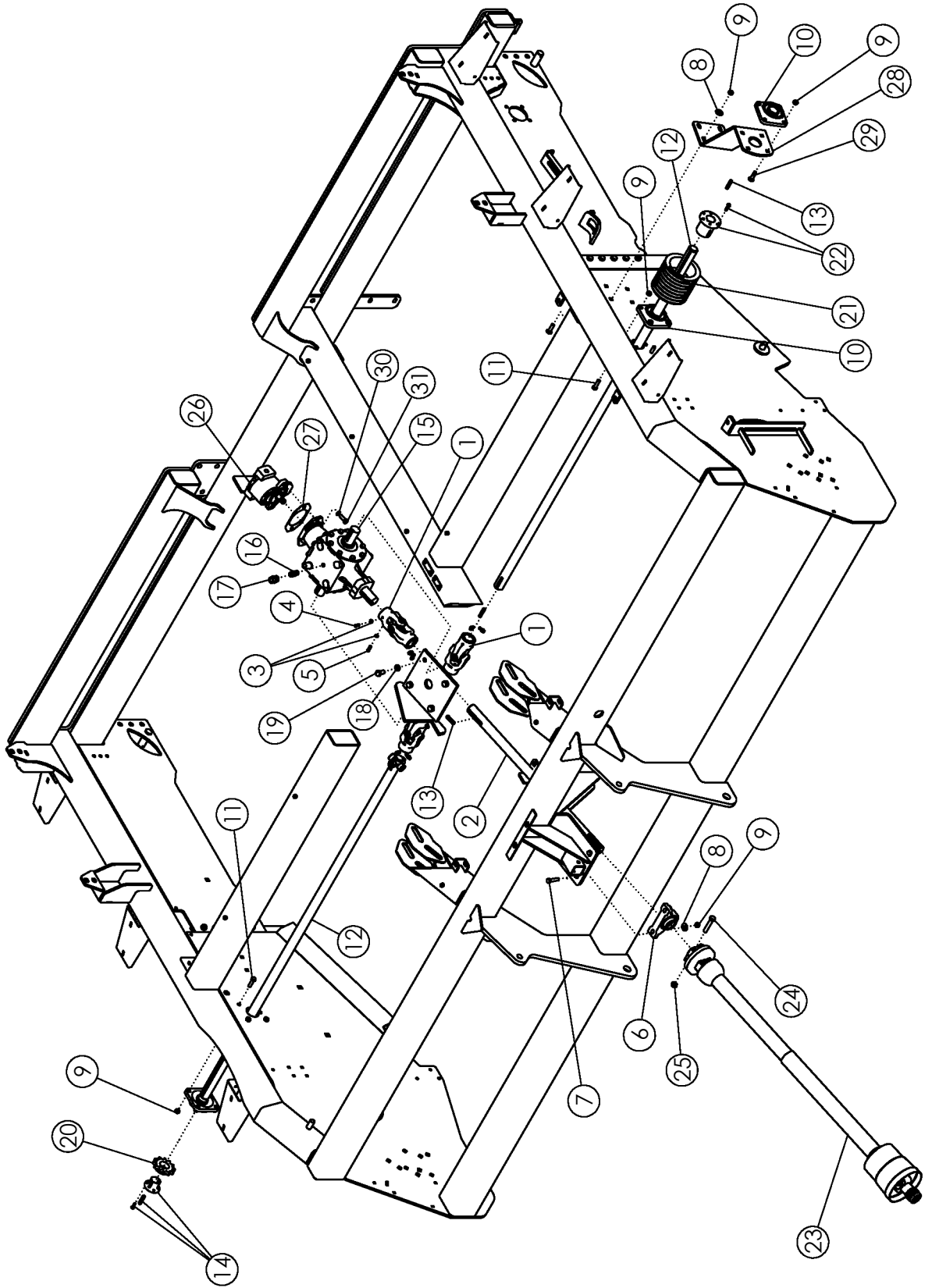

MAIN DRIVE: ONBOARD OPTION

ITEM	PART NO.	DESCRIPTION	QTY
1	53642	U-JOINT	3
2	56775	SPLINE SHAFT	1
3	1013519	NUT-JAM: .38 NC GR2 ZP	12
4	1032511	SCREW-SET:SQ HD .38 X .75	6
5	50813	SCREW-SET: SQ HD .38 X 1.00 ZP	6
6	52405	BEARING-PILLOW 1.75	1
7	1017708	BOLT-HEX: .50 X 2.25 NC GR5 ZP	2
8	1014443	WASHER-FLAT: .50 ZP	6
9	1027461	NUT-TOPLOCK: .50 NC GR5 ZP	18
10	52404	BEARING-FLANGE 1.75	3
11	1011608	BOLT-HEX: .50 X 1.75 NC GR5 ZP	8
12	56759	SHAFT-DRIVE 8R	2
13	50152	KEY .38 X .38 X 2.00	10
14	53641	HUB P1 1.75 (WITH KEY)	1
15	62015	GEARBOX: 1.81:1 W/ C MOUNT BLACK	1
16	69128	FTG-ADAPTER: 8MP-8MP 4" LONG	1
17	55730	FTG-ADAPTER: 8FP-8FP	1
18	1011813	WASHER-LOCK: .63 ZP	4
19	1032509	BOLT-HEX: .63 X 1.25 NC GR5 ZP	4
20	62034	SPROCKET H80-P12	1
21	57680	SHEAVE 8B62Q	1
	57681	SHEAVE 8B68Q	
	57679	SHEAVE 8B56Q	
22	55123	HUB Q2 1.75	1
23	301575	PTO-CV 1 3/8"-21 X 90" WEASLER (HRV)	1
	301558	PTO-CV 1 3/4"-20 X 90" WEASLER (HRV)	
24	1030704	BOLT-HEX: .63 X 3.25 NC GR5 ZP	2
25	1016595	NUT-TOPLOCK: .63 NC GR5 ZP	2
26	303588	PUMP-5.4^3 SAE C (CW) (3500 PSI)	1
27	301066	PLATE-ADAPTER SAE "C" PUMP	1
28	68111	BRACKET-BRACE BEARING	1
29	59517	BOLT-CRG: .50 X 1.75 NC GR5 ZP	8
30	1011581	WASHER-LOCK: .50 ZP	2
31	1011607	BOLT-HEX: .50 X 1.50 NC GR5 ZP	2

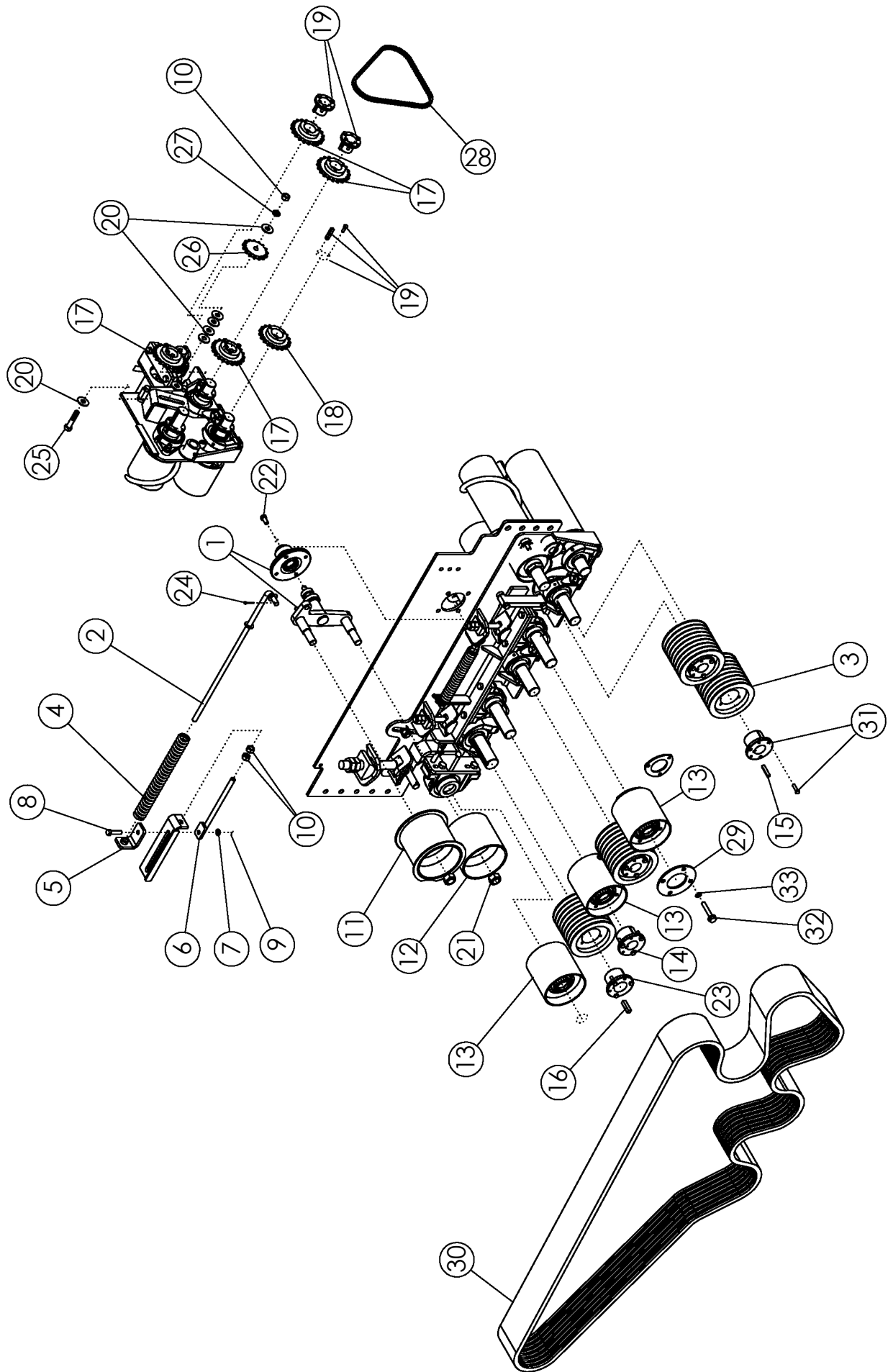

CLEANING ROLL DRIVE

ITEM	PART NO.	DESCRIPTION	QTY
1	56422	ASSY-SPINDLE & HUB	1
2	56711	ROD-PLATED	1
3	57680	SHEAVE 8B62Q	4
4	56853	SPRING	1
5	56708	HOLDER-PLATED	1
6	56707	ADJUSTMENT ROD ZP	1
7	1011581	WASHER-LOCK: .50 ZP	1
8	1011609	BOLT-HEX: .50 X 2.00 NC GR5 ZP	1
9	1011577	NUT-HEX: .50 NC GR2 ZP	1
10	1011578	NUT-HEX: .63 NC GR2 ZP	3
11	58295	WLDMT-IDLER	1
12	56425	TIGHTENER IDLER	1
13	301822	ASSY-REVERSE PULLEY 8R W/LOCK COLLAR	3
14	50335	HUB Q1 1.75	2
15	50152	KEY .38 X .38 X 2.00	5
16	57995	KEY .50 X .50 X 2.00	1
17	53649	SPROCKET H60-P20	2
18	62106	SPROCKET H60-P19	1
19	53641	HUB P1 1.75 (WITH KEY)	3
20	1013024	WASHER-FLAT: .63 ZP	7
21	1016969	NUT-TOPLOCK: 1.00 NC GR5 ZP	2
22	1015558	BOLT-HEX: .50 X 1.00 NF GR5 ZP	4
23	58248	HUB Q2 2.00	1
24	1019827	PIN-COTTER: .19 X 1.00 NP	1
25	1011624	BOLT-HEX: .63 X 3.00 NC GR5 ZP	1
26	53651	7348-2 SPROCKET IDLER	1
27	1011813	WASHER-LOCK: .63 ZP	1
28	303566	CHAIN-ROLLER CP 60H-1R-052	1
29	301718	PLATE-REVERSE GRABROLL COVER	1
30	64474	V-BELT 8B195	1
31	55123	HUB Q2 1.75	3
32	301936	BOLT-FLG: .50 X 2.50 NC GR8 YZP	8
33	301937	WASHER-STAR: .50 ZP	8

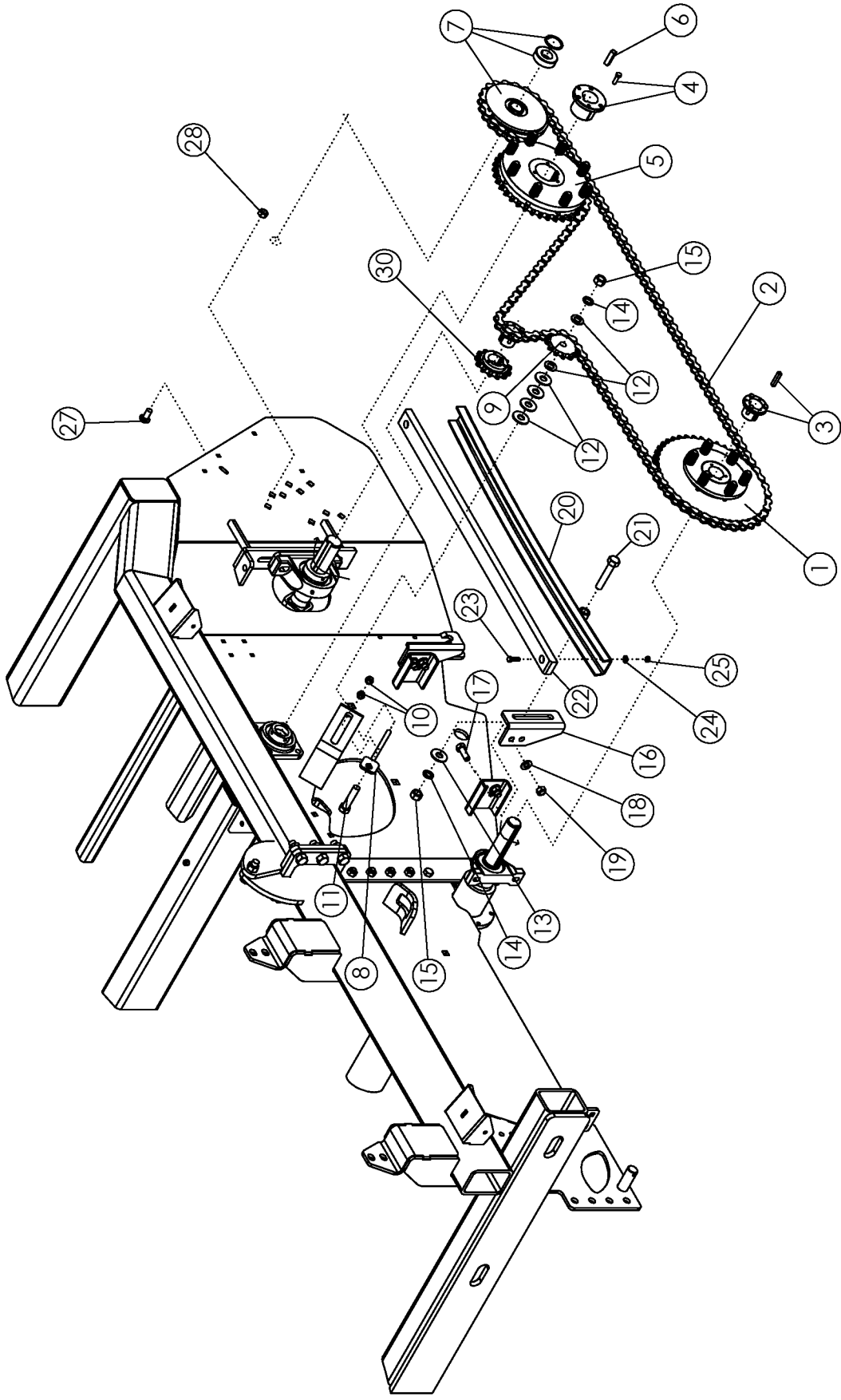

APRON/PADDLE SHAFT DRIVE

ITEM	PART NO.		QTY
1	58335	SPROCKET-CLUTCH 80P45 PRESET	1
	73034	SPROCKET H80-P14 (ROCK ONLY)	
2	303561	CHAIN-ROLLER CP 80H-1R-177	1
	303562	CHAIN-ROLLER CP 80H-1R-182	
3	53641	HUB P1 1.75 (WITH .38 X 2.00 KEY)	1
4	50385	HUB Q1 2.00	1
5	57993	SPROCKET-CLUTCH 80Q36 PRESET	1
	69630	SPROCKET-CLUTCH 80Q51 PRESET (PLASTIC PADDLE)	
6	57995	KEY .50 X .50 X 2.00	1
7	56851	SPROCKET-IDLER H8025 X 1.44	1
8	56864	WLDMT-ADJUSTER	1
9	56334	SPROCKET-IDLER 8012	1
10	1011577	NUT-HEX: .50 NC GR2 ZP	2
11	1032271	BOLT-HEX: .75 X 3.25 NC GR5 ZP	1
12	1012634	WASHER-FLAT: SAE .75 ZP	6
13	1030702	WASHER-FLAT: .75 ZP	2
14	1012061	WASHER-LOCK: .75 ZP	3
15	1011620	NUT-HEX: .75 NC GR5 ZP	3
16	57804	MOUNT	2
17	1013918	BOLT-HEX: .63 X 1.75 NC GR5 ZP	4
18	1013004	WASHER-FLAT: SAE .63 ZP	4
19	1016595	NUT-TOPLOCK: .63 NC GR5 ZP	4
20	57853	WLDMT-SUPPORT	1
21	1011625	BOLT-HEX: .75 X 4.00 NC GR5 ZP	2
22	57827	SLIDE-CHAIN	1
23	1011601	BOLT-HEX: .38 X 1.25 NC GR5 ZP	2
24	1014608	WASHER-FLAT: SAE .38 ZP	2
25	1016999	NUT-TOPLOCK: .38 NC GR5 ZP	2
26	69625	WLDMT-IDLER PADDLE SHAFT	1
27	72063	BOLT-CRG: .63 X 1.50 NC GR5 ZP	3
28	1016595	NUT-TOPLOCK: .63 NC GR5 ZP	3
29	68136	PLUG- .625 SQUARE PLASTIC (NOT SHOWN)	4
30	56339	SPROCKET H80-P13	1

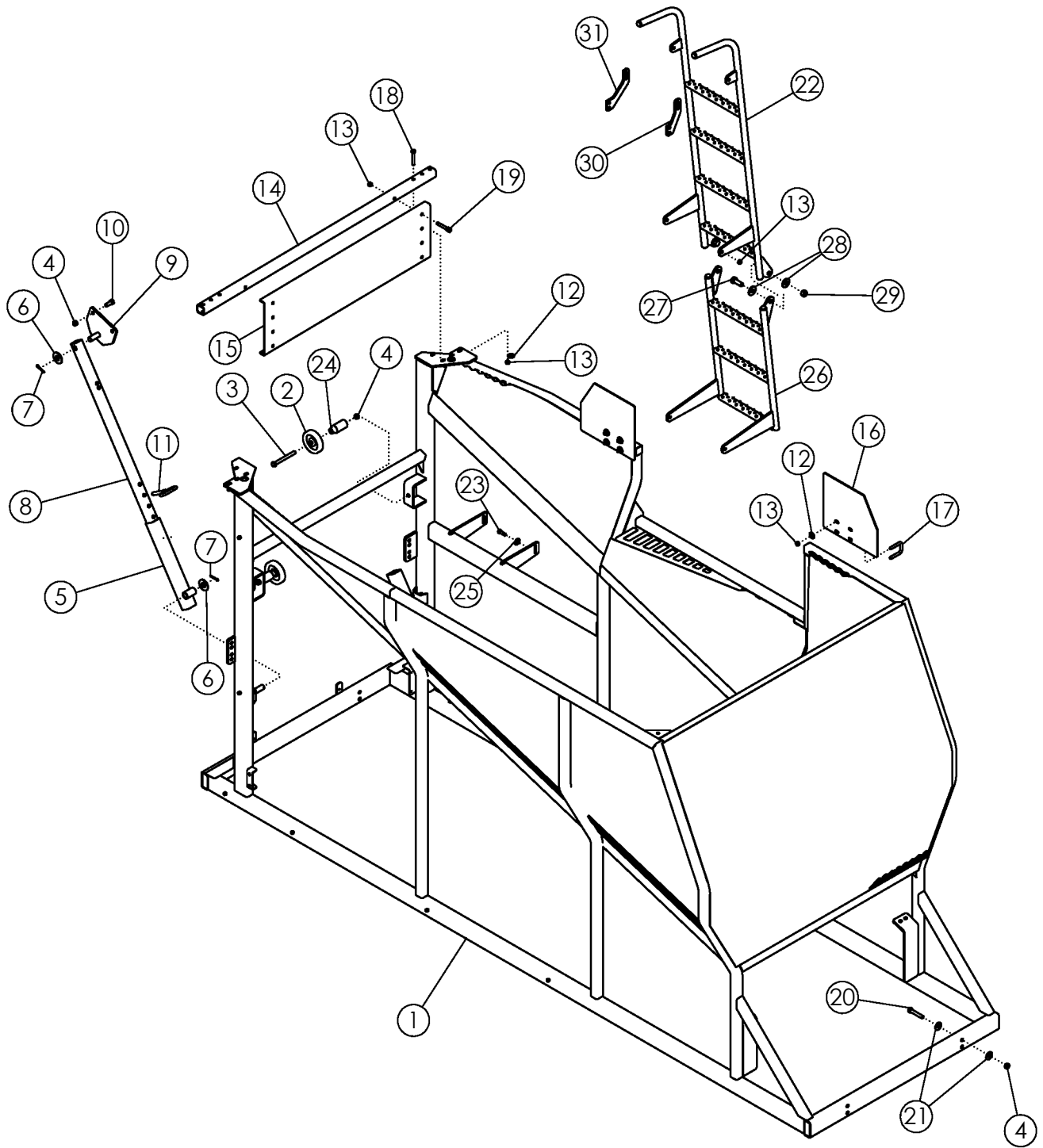

TANK

ITEM	PART NO.	DESCRIPTION	QTY
1	69782	WLDMT-TANK SCRUB 8R	1
2	53825	BOGIE WHEEL 5"	2
3	1013068	BOLT-HEX: .63 X 6.00 NC GR5 ZP	2
4	1016595	NUT-TOPLOCK: .63 NC GR5 ZP	14
5	302643	WLDMT-LOCK SLIDE	2
6	1020685	WASHER-FLAT: 1.00 ZP	4
7	1016944	PIN-COTTER: .25 X 2.00 ZP	4
8	302641	TUBE-LOCK	2
9	54785	WLDMT-LOCK BRACKET	2
10	1014349	BOLT-HEX: .63 X 1.50 NC GR5 ZP	4
11	1030947	PIN-HITCH: .63 X 4.00 ZP W/HAIRPIN	2
12	1014443	WASHER-FLAT: .50 ZP	22
13	1027461	NUT-TOPLOCK: .50 NC GR5 ZP	28
14	64749	TUBE-STRIKER	1
15	64574	PLATE-STRIKER	1
16	57917	PLATE-EXTENSION	2
17	65658	U-BOLT: .50 X 3 X 2.06 X 3	4
18	1017719	BOLT-HEX: .50 X 3.25 NC GR5 ZP	4
19	1011611	BOLT-HEX: .50 X 3.00 NC GR5 ZP	2
20	1014000	BOLT-HEX: .63 X 3.50 NC GR5 ZP	8
21	1013024	WASHER-FLAT: .63 ZP	16
22	72420	WLDMT-LADDER TOP	1
23	1011607	BOLT-HEX: .50 X 1.50 NC GR5 ZP	10
24	64192	STAND-OFF 4.00	2
25	1011584	WASHER-FLAT: SAE .50 ZP	4
26	301320	WLDMT-LADDER BOTTOM 3-RUNG	1
27	1012060	BOLT-HEX: .75 X 2.00 GR5 ZP	2
28	1030702	WASHER-FLAT: .75 ZP	4
29	1017000	NUT-TOPLOCK: .75 NC GR5 ZP	2
30	301383	PLATE-LADDER MOUNT LH	1
31	301384	PLATE-LADDER MOUNT RH	1
32	59615	DECAL-REFLECTIVE TAPE (NOT SHOWN)	8

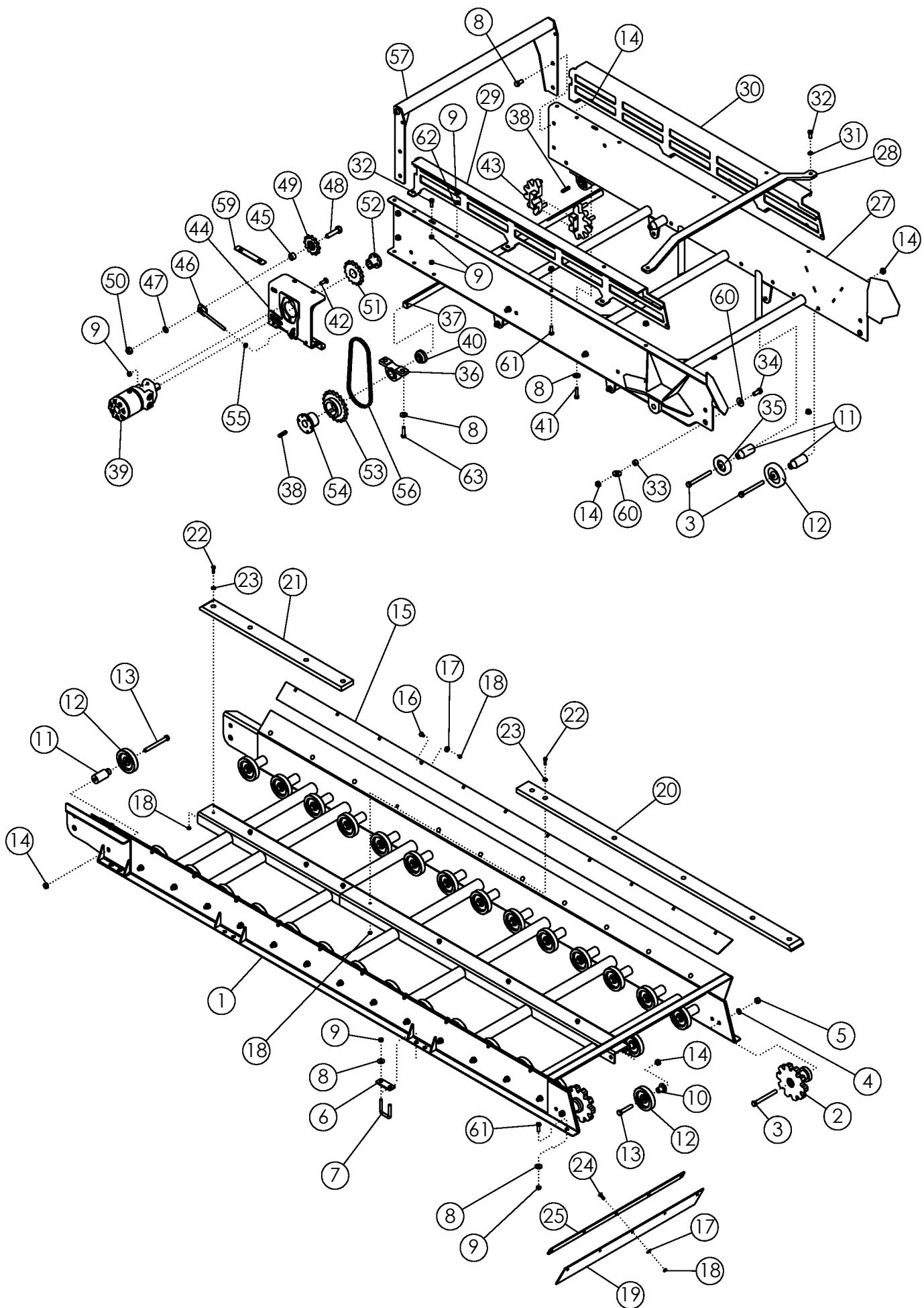

ELEVATOR AND BOOM ASSEMBLY 8 ROW

ITEM	PART NO.	DESCRIPTION	QTY
1	301505	WLDMT-ELEVATOR 8R	1
2	63813	SPROCKET-IDLER 50MM 10T	2
	54824	SPROCKET-IDLER 56MM	
3	1013068	BOLT-HEX: .63 X 6.00 NC GR5 ZP	44
4	1011813	WASHER-LOCK: .63 ZP	2
5	1011578	NUT-HEX: .63 NC GR2 ZP	2
6	64748	PLATE-ELEVATOR BACKING	8
7	65658	U-BOLT: .50 X 3 X 2.06 X 3	6
8	1014443	WASHER-FLAT: .50 ZP	25
9	1027461	NUT-TOPLOCK: .50 NC GR5 ZP	30
10	58971	STAND OFF 1.50"	2
11	64192	STAND OFF	42
12	53825	BOGIE WHEEL 5"	40
13	65825	BOLT-HEX: .63 X 3.25 NC GR5 ZP	2
14	1016595	NUT-TOPLOCK: .63 NC GR5 ZP	50
15	64550	SHEET-BELT PROTECTOR	2
16	59488	BOLT-CRG: .38 X 1.00 NC GR5 ZP	28
17	1011828	WASHER-FLAT .38 ZP	33
18	1016999	NUT-TOPLOCK: .38 NC GR5 ZP	43
19	64609	FLAP-ELEVATOR	1
20	69822	SLIDE-ELEVATOR PLASTIC 6R/8R/12R	1
21	301507	SLIDE-ELEVATOR PLASTIC 8R	1
22	1011601	BOLT-HEX: .38 X 1.25 NC GR5 ZP	10
23	1014608	WASHER-FLT: SAE .38 ZP	12
24	1016362	BOLT-CRG: .38 X 1.25 NC GR5 ZP	5
25	64608	STRIP-BOLTING	1
26	68073	BELT-50MM ELEVATOR 8R (NOT SHOWN)	1
	68072	BELT-56MM ELEVATOR 8R (NOT SHOWN)	
	301516	BELT- 56MM ELEVATOR 8R DOUBLE (NOT SHOWN)	
	301517	BELT- 50MM ELEVATOR 8R DOUBLE (NOT SHOWN)	
27	53450	WLDMT-ELEVATOR BOOM 4R/6R/8R	1
28	54803	CROSS BRACE-BOOM	1
29	301525	PLATE-BOOM EXTENSION SHORT FRONT	1
30	301524	PLATE-BOOM EXTENSION SHORT REAR	1
31	1011581	WASHER-LOCK: .50 ZP	2
32	1011606	BOLT-HEX: .50 X 1.25 NC GR5 ZP	4
33	53449	SLEEVE-HINGE	2
34	1014349	BOLT-HEX: .63 X 1.50 NC GR5 ZP	6
35	53854	BOGIE WHEEL 4"	4
36	53708	PILLOWBLOCK BEARING UCP-206-20	2

CONTINUED

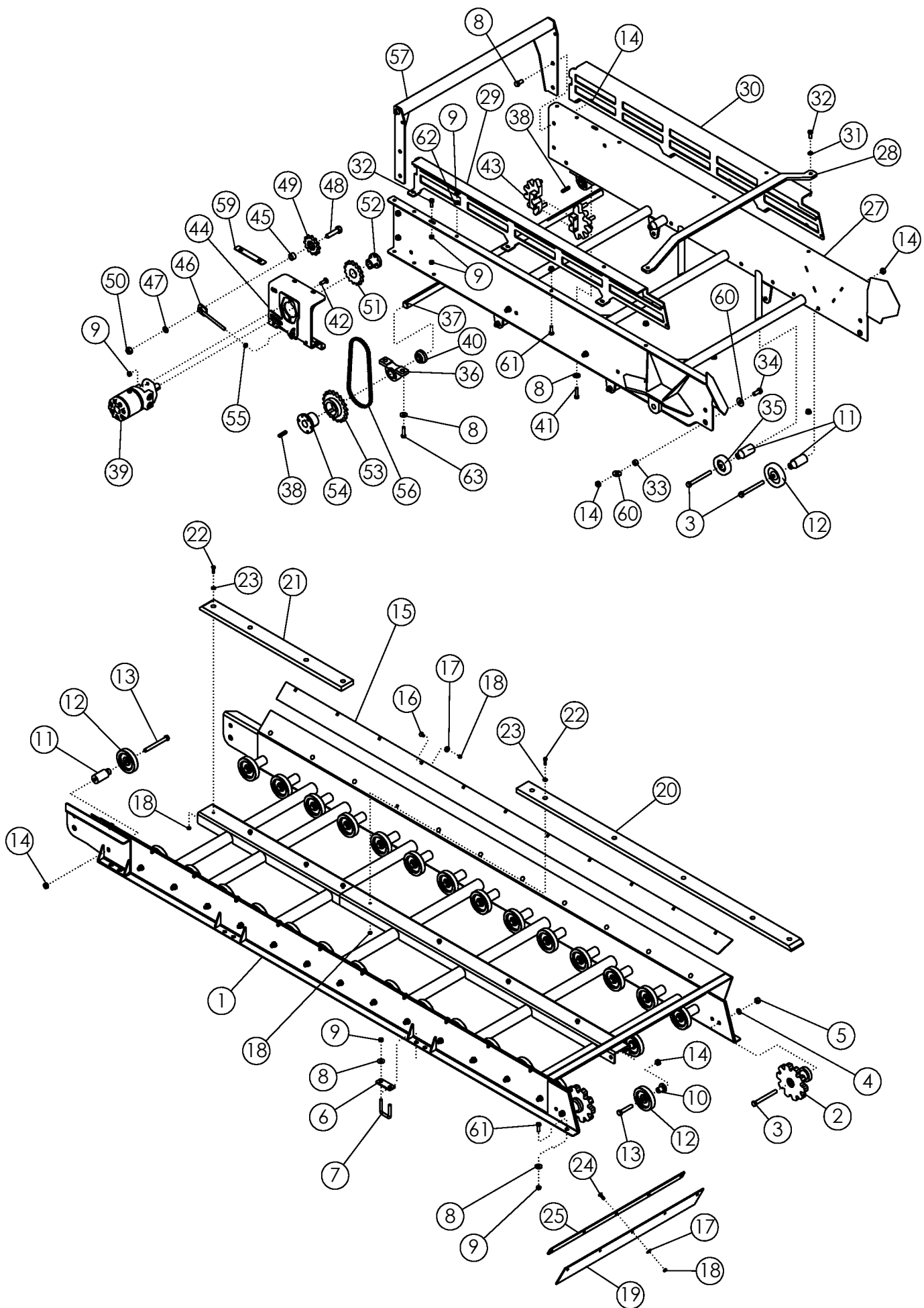

ELEVATOR AND BOOM ASSEMBLY (CONTINUED)

ITEM	PART NO.	DESCRIPTION	QTY
37	68650	SHAFT-HEAD Ø1.750	1
38	50152	KEY .38 X .38 X 2.00	3
39	57686	MOTOR-HYDRAULIC 32.3IN ³ /REV	1
	57880	SEAL KIT FOR 57686	
40	52382	SEAL PROTECTOR 1-3/4"	2
41	1011608	BOLT-HEX: .50 X 1.75 NC GR5 ZP	2
42	1011660	BOLT-CRG: .50 X 1.50 NC GR5 ZP	2
43	68658	SPROCKET-SPLIT 56MM 10T Ø1.750	2
	68659	SPROCKET-SPLIT 50MM 12T Ø1.750	
	301521	SPROCKET-SPLIT 50MM 12T Ø1.750 DOUBLE BELT	
44	64627	WLDMT-REDUCTION MOUNT	1
45	58086	SPACER-CHAIN IDLER ZP	1
46	63876	TENSIONER ZP	1
47	1012061	WASHER-LOCK: .75 ZP	1
48	1012059	BOLT-HEX: .75 X 3.00 NC GR5 ZP	1
49	56334	SPROCKET-IDLER 8012	1
50	1011620	NUT-HEX: .75 NC GR2 ZP	1
51	64155	SPROCKET H80-P15	1
52	53719	HUB P1 1-1/4"	1
53	56650	SPROCKET H80-Q20	1
54	50752	HUB Q1 1-7/16"	1
55	1011591	NUT-JAM: .50 NC ZP	2
56	64654	CHAIN-ROLLER 80H-1R-038	1
	64675	LINK-OFFSET #80H	2
57	64578	WLDMT-BOOM END SUPPORT	1
58	1032509	BOLT-HEX: .63 X 1.25 NC GR5 ZP	4
59	64732	PLATE-SHIM 0.120	1
60	1013024	WASHER-FLAT: .63 ZP	4
61	1011607	BOLT-HEX: .50 X 1.50 NC GR5 ZP	8
62	1011584	WASHER-FLAT: SAE .50 ZP	12
63	1017708	BOLT-HEX: .50 X 2.25 NC GR5 ZP	2

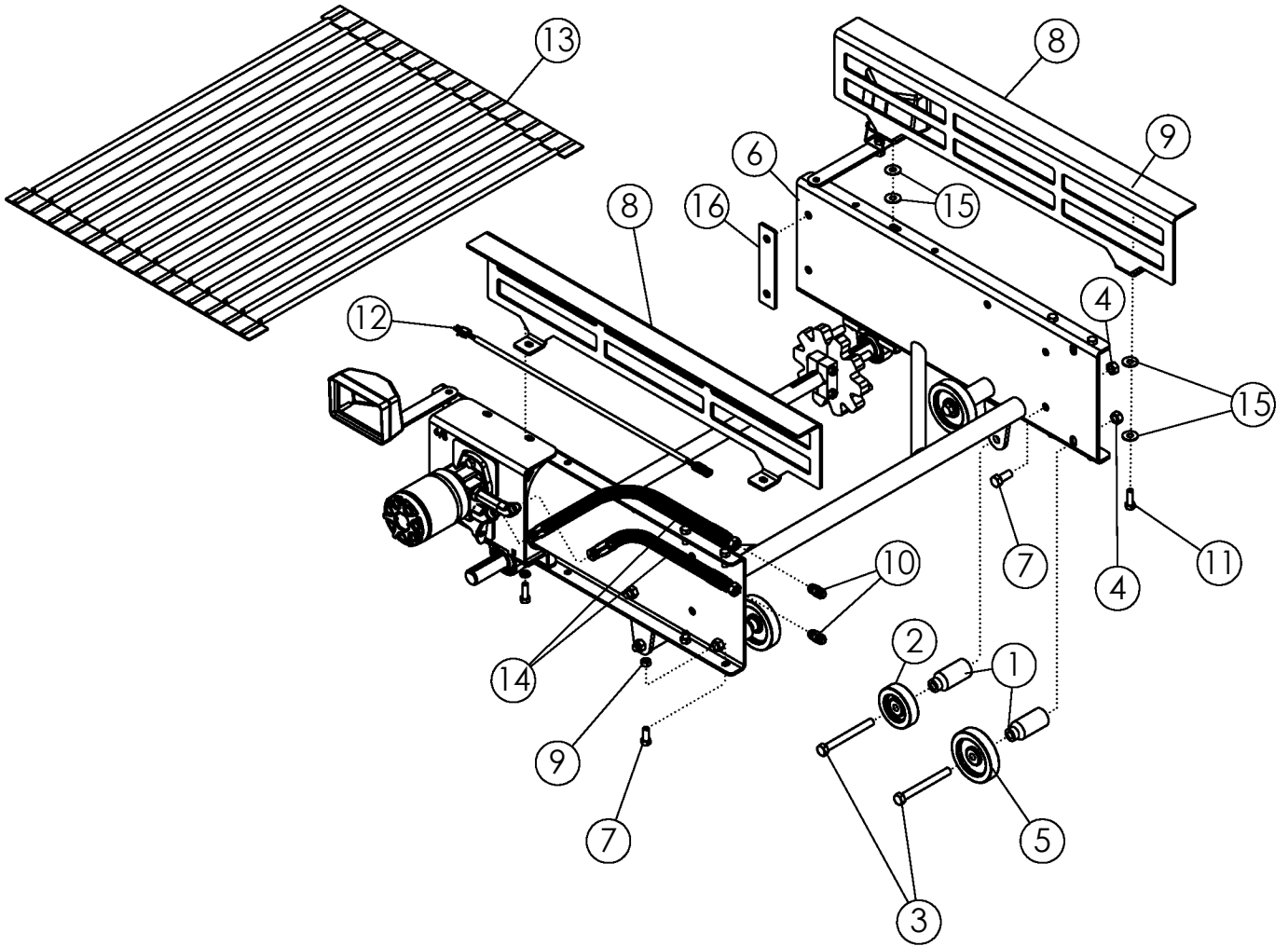

BOOM EXTENSION 30" 50MM/56MM (OPTIONAL)

ITEM	PART NO.	DESCRIPTION	QTY
1	64192	STAND OFF	6
2	53854	BOGIE WHEEL 4"	2
3	1013068	BOLT-HEX: .63 X 6.00 NC GR5 ZP	6
4	1016595	NUT-TOPLOCK: .63 NC GR5 ZP	10
5	53825	BOGIE WHEEL 5"	4
6	68708	WLDMT-BOOM EXTENSION	1
7	1011606	BOLT-HEX: .50 X 1.25 NC GR5 ZP	8
8	302241	WLDMT-BOOM RISER EXT. RAIL	2
9	1027461	NUT-TOPLOCK: .50 NC GR5 ZP	12
10	58194	FTG-ADAPTER: 8MJ-8MJ	2
11	1011607	BOLT-HEX: .50 X 1.50 NC GR5 ZP	4
12	301717	HARNESS-EXTENSION: 32" 2 WIRE	2
13	68077	BELT-50MM: .50 X 42 X 30LPR	1
	68076	BELT-56MM: .50 X 42 X 27LPR	
	301836	BELT-56MM ELEVATOR EXT DOUBLE	
	301812	BELT-50MM ELEVATOR EXT DOUBLE	
14	57676	HOSE: .50 X 31 8FJX-8FJX	2
15	1014443	WASHER-FLAT: .50 ZP	17
16	68710	PLATE-BOOM SUPPORT SPACER	2
17	1014349	BOLT-HEX: .63 X 1.50 NC GR5 ZP	4

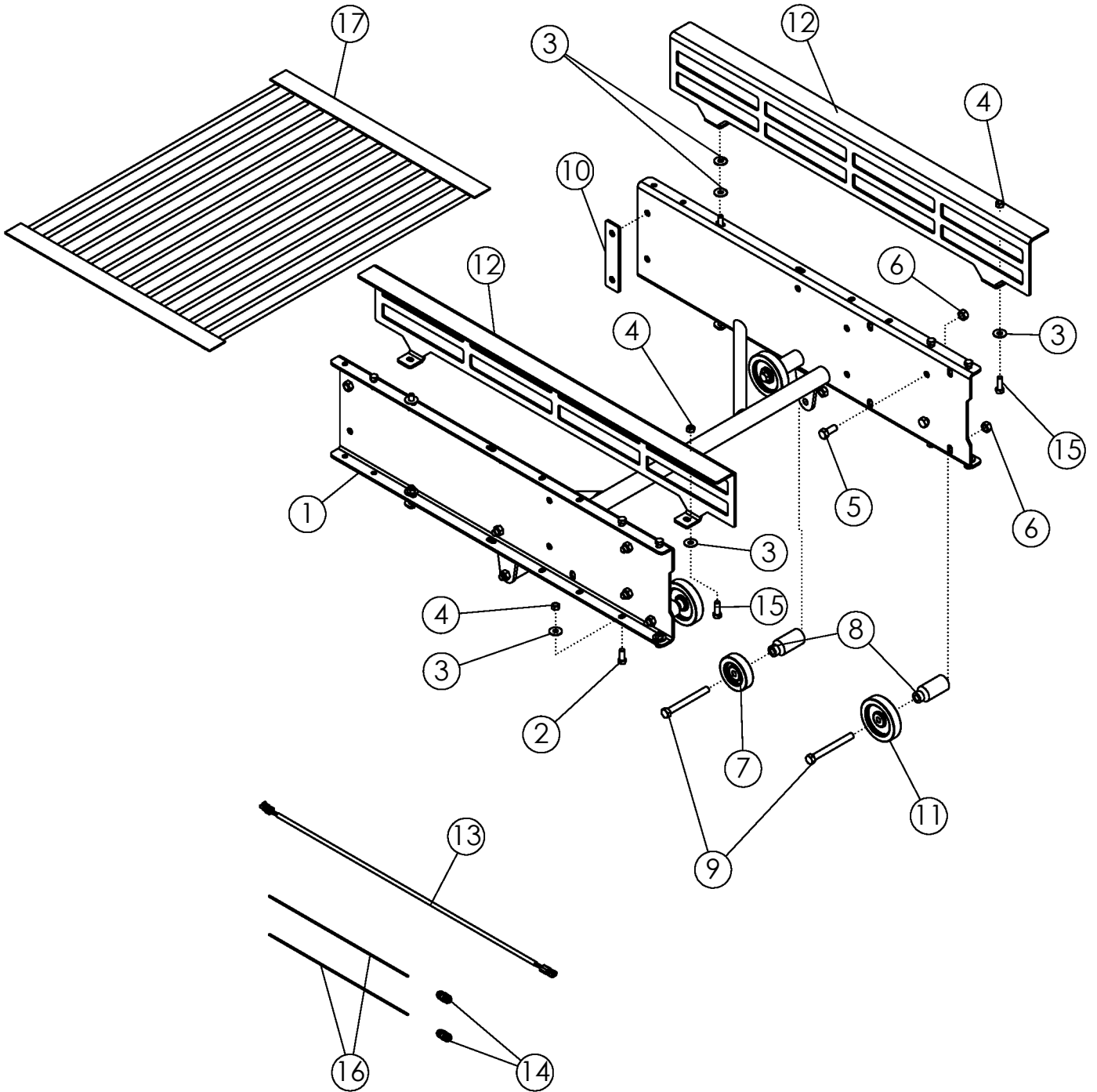

BOOM EXTENSION 42" 56MM (OPTIONAL)			
ITEM	PART NO.	DESCRIPTION	QTY
1	301090	WLDMT- BOOM EXTENSION Ø1.75 SHAFT LONG	1
2	1011606	BOLT-HEX: .50 X 1.25 NC GR5 ZP	8
3	1014443	WASHER-FLAT: .50 ZP	17
4	1027461	NUT-TOPLOCK: .50 NC GR5 ZP	12
5	1014349	BOLT-HEX: .63 X 1.50 NC GR5 ZP	4
6	1016595	NUT-TOPLOCK: .63 NC GR5 ZP	10
7	53854	BOGIE WHEEL 4"	2
8	64192	STAND OFF	6
9	1013068	BOLT-HEX: .63 X 6.00 NC GR5 ZP	6
10	68710	PLATE-BOOM SUPPORT SPACER	2
11	53825	BOGIE WHEEL 5"	4
12	302242	PLATE-BOOM RAILING-42" BOOM EXT	2
13	302781	HARNES-EXTENSION 44" 2 WIRE DEUTSCH	2
14	58194	FTG-ADAPTER: 8MJ-8MJ	2
15	1011607	BOLT-HEX: .50 X 1.50 NC GR5 ZP	4
16	301105	HOSE: .50 X 043 8FJX-8FJX	2
17	301106	BELT-56MM ELEVATOR EXTENSION 38 LPR	1

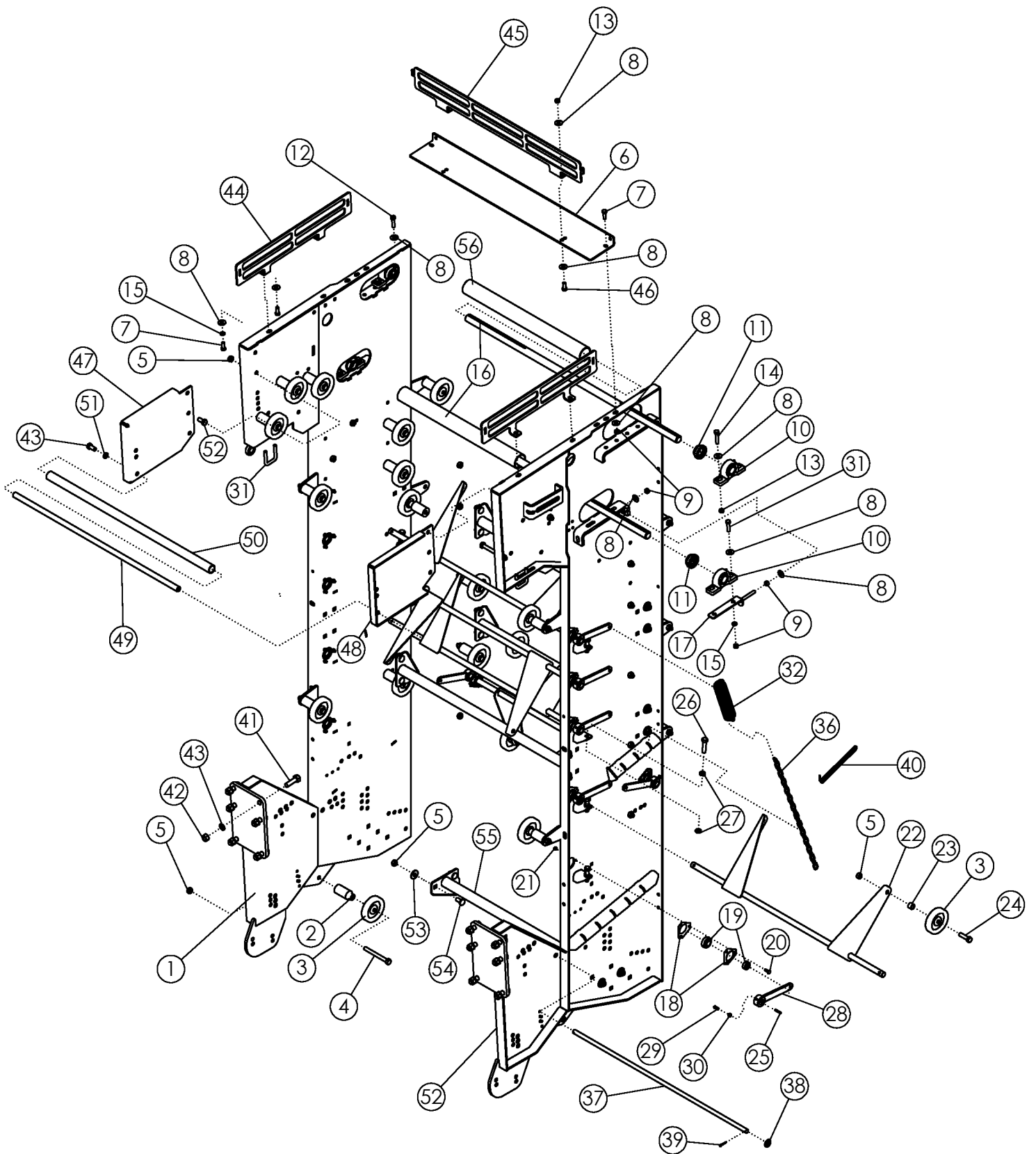

REAR SCRUB

ITEM	PART NO.	DESCRIPTION	QTY
1	300402	WLDMT-REAR SCRUB PANEL RH	1
2	64192	STAND OFF	28
3	53825	BOGIE WHEEL 5"	40
4	1013068	BOLT-HEX: .63 X 6.00 NC GR5 ZP	28
5	1016595	NUT-TOPLOCK: .63 NC GR5 ZP	64
6	57916	BAR-STRIPPER	1
7	1011606	BOLT-HEX: .50 X 1.25 NC GR5 ZP	2
8	1014443	WASHER-FLAT: .50 ZP	28
9	1011577	NUT-HEX: .50 NC GR2 ZP	14
10	52405	PILLOWBLOCK BEARING 1.75	4
11	52382	SEAL PROTECTOR 1.75	4
12	1011609	BOLT-HEX: .50 X 2.00 NC GR5 ZP	4
13	1027461	NUT-TOPLOCK: .50 NC GR5 ZP	10
14	1011610	BOLT-HEX: .50 X 2.50 NC GR5 ZP	4
15	1011581	WASHER-LOCK: .50 ZP	2
16	68650	SHAFT-HEAD 1.75	2
17	68655	TIGHTENER-ZP	2
18	53945	TRIANGLE FLANGETTE	24
19	53944	BEARING-INSERT 1" WTH LOCKING COLLAR	12
20	1017255	BOLT-CRG: .31 X 1.00	36
21	1030700	NUT-TOPLOCK: .31 NC GR5 ZP	36
22	53401	WLDMT-PENDULUM	6
23	64253	SPACER ZP	12
24	1017526	BOLT-HEX: .63 X 2.25 NC GR5 ZP	12
25	1012975	KEY .250 X .250 X 1.250	12
26	69390	BOLT-HEX: .63 X 2.50 NC GR5 ZP FULL	8
27	1026259	NUT-JAM: .63 NC GR2 ZP	16
28	50718	ARM-ZP	12
29	50813	SCREW-SET: SQ HD .38 X 1.00 ZP	12
30	1013519	NUT-JAM: .38 NC GR2 ZP	12
31	65658	U-BOLT: .50 X 3 X 2.063 X 3	2
32	53159	SPRING	12
33	57937	CHAIN-LINK: .19 X 8.00 (NOT SHOWN)	4
34	57938	CHAIN-LINK: .19 X 20.00 (NOT SHOWN)	2
35	57939	CHAIN-LINK: .19 X 24.00 (NOT SHOWN)	4
36	57940	CHAIN-LINK: .19 X 30.00	2
37	62896	ROD-SCRUB CLEANER	1
38	1012634	WASHER-FLAT: SAE .75 ZP	2
39	1011984	PIN-COTTER: .16 X 1.50 ZP	2
40	1017248	TIE, CABLE	4

CONTINUED

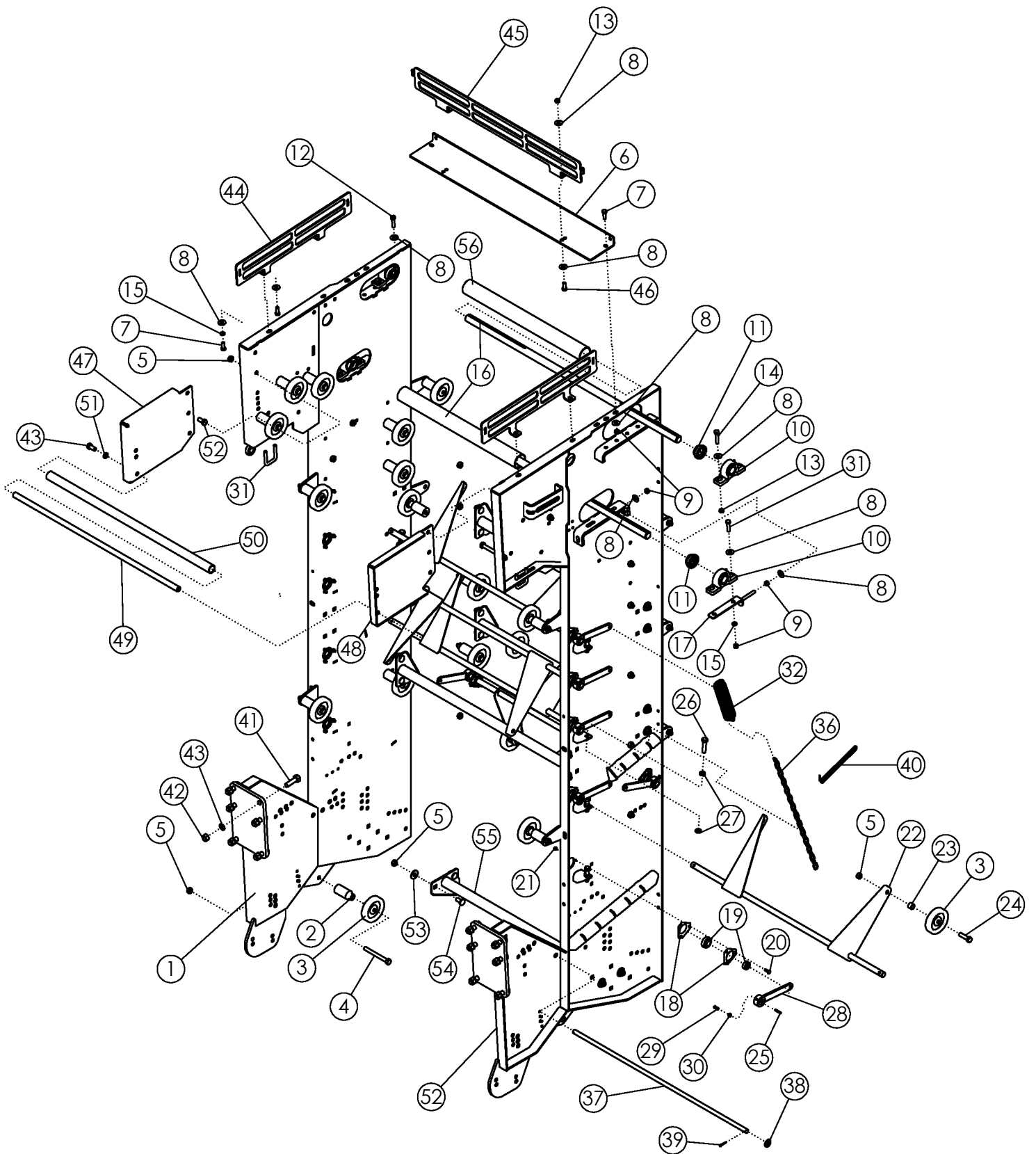

REAR SCRUB (CONTINUED)

ITEM	PART NO.	DESCRIPTION	QTY
41	1016598	BOLT- HEX: .75 X 2.50 NC GR5 ZP	12
42	1017000	NUT-TOPLOCK: .75 NC	12
43	1032509	BOLT-HEX: .63 X 1.25 NC GR5 ZP	8
44	73127	PLATE-SCRUB EXT.-SIDE	2
45	58898	PLATE-SCRUB EXT-REAR	1
46	1011607	BOLT-HEX: .50 X 1.50 NC GR5 ZP	6
47	54805	REAR SCRUB EXTENSION RH	1
48	54778	REAR SCRUB EXTENSION LH	1
49	56754	PIPE-THREADED	1
50	56773	PIPE-PLASTIC	1
51	1011813	WASHER-LOCK: .63 ZP	2
52	300401	WLDMT-REAR SCRUB PANEL LH	1
53	1013024	WASHER-FLAT: .63 ZP	16
54	72063	BOLT-CRG: .63 X 1.50 NC GR5 ZP	16
55	300403	WLDMT-CROSS TUBE	4
56	302402	PIPE-PLASTIC	2

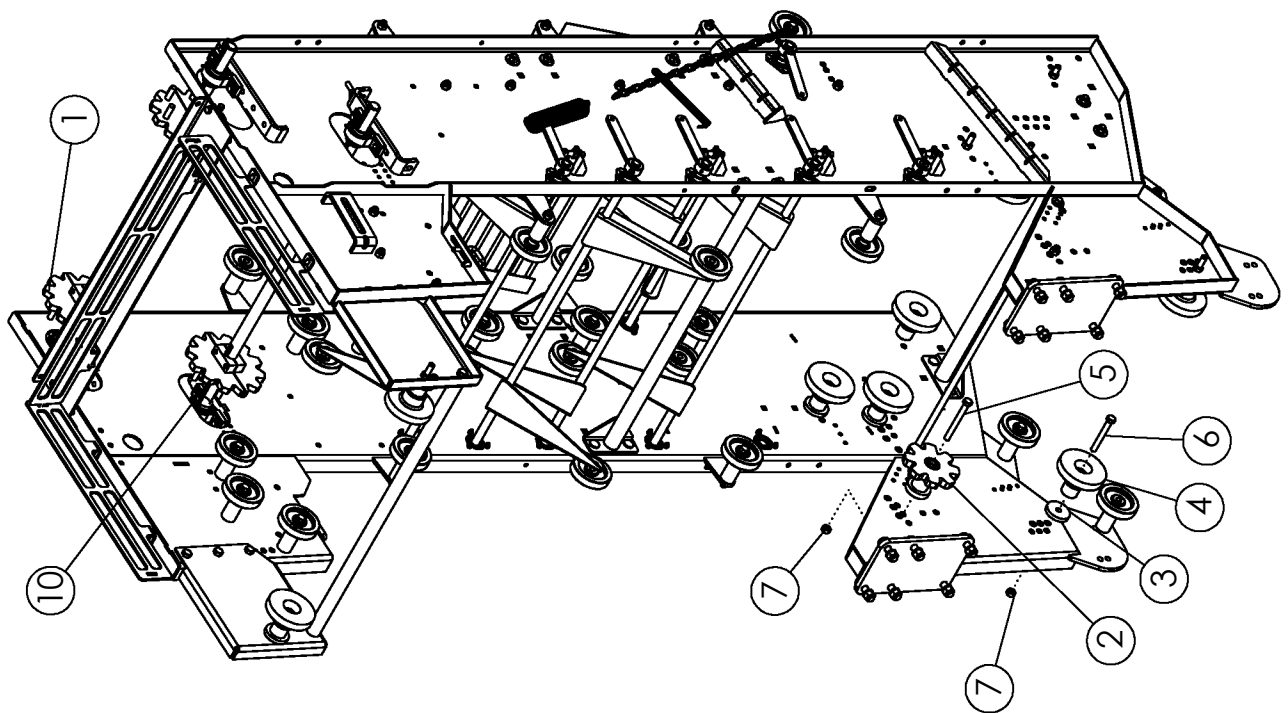
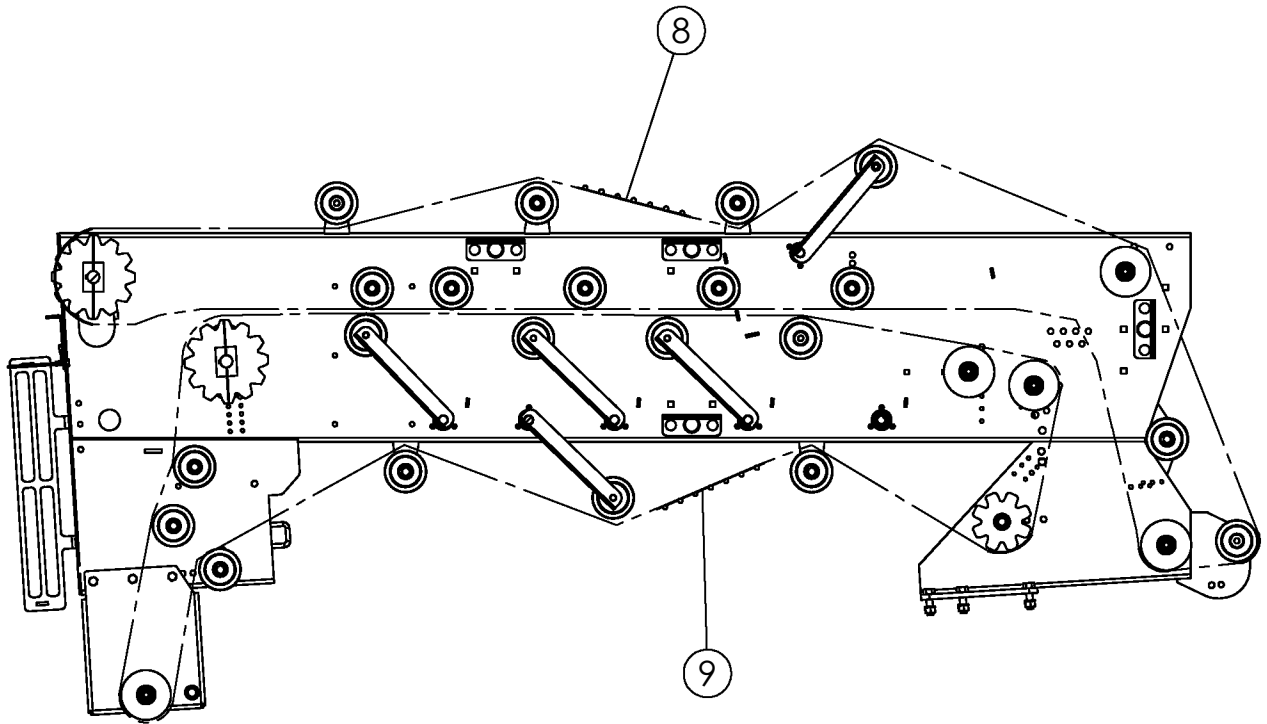

REAR SCRUB: BELTED CHAIN 56MM			
ITEM	PART NO.	DESCRIPTION	QTY
1	68651	SPROCKET-SPLIT 56MM	2
	68667*	SPROCKET-56MM 14T URETHANE (OUTSIDE)	2
2	54824	SPROCKET-IDLER 56MM	2
3	62932	PLATE-SHIM	10
4	54042	ROLLER-FLANGE 6"	10
5	1013068	BOLT-HEX: .63 X 6.00 NC GR5 ZP	2
6	1013816	BOLT-HEX: .63 X 5.00 NC GR5 ZP	10
7	1016595	NUT-TOPLOCK: .63 NC GR5 ZP	12
8	53842	BELT-56MM 1/2 X 42 X 156 LPR	1
9	62141	BELT-56MM 1/2 X 42 X 136 LPR	1
10	68651	SPROCKET-SPLIT 56MM (INSIDE)	2
11	50152	KEY .375 X .375 X 2.000 (NOT SHOWN)	4
	58201*	KEY .375 X .375 X 3.000 (NOT SHOWN)	
REAR SCRUB: BELTED CHAIN 56MM FLANGE ROLLER			
1	68651	SPROCKET-SPLIT 56MM 12T Ø1.75	2
2	59057	ROLLER-RUBBER FLANGE 6.5"	2
3	1013024	WASHER-FLAT: .63 ZP	20
4	59057	ROLLER-RUBBER FLANGE 6.5"	8
5	65825	BOLT-HEX: .63 X 3.25 NC GR5 ZP	2
6	65825	BOLT-HEX: .63 X 3.25 NC GR5 ZP	8
7	1016595	NUT-TOPLOCK: .63 NC GR5 ZP	10
8	53842	BELT-56MM OUTSIDE SCRUB 6R/8R	1
9	62141	BELT-56MM INSIDE SCRUB 6R/8R	1
10	68651	SPROCKET-SPLIT 56MM 12T Ø1.75	2
11	50152	KEY .375 X .375 X 2.000	4

* Urethane option only

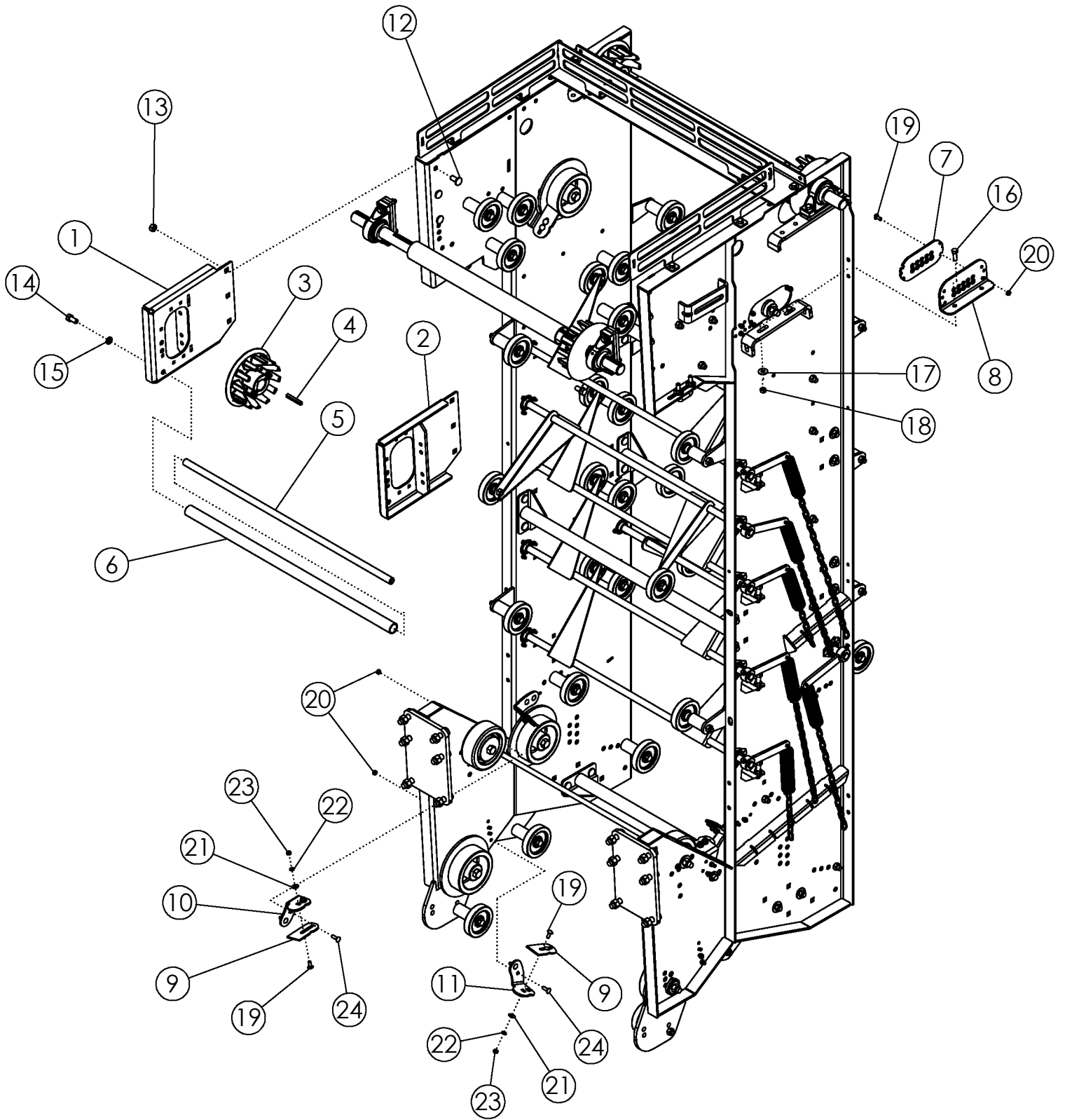

**REAR SCRUB: G1 55MM BELTED CHAIN HP ASSEMBLY
#302847**

ITEM	PART NO.	DESCRIPTION	QTY
1	302907	WLDMT-IN TANK HEADSHAFT MOUNT RH	1
2	302906	WLDMT-IN TANK HEADSHAFT MOUNT LH	1
3	302873	SPROCKET-SPLIT 55MM 12T HP BELT DRIVE	4
4	58201	KEY .375 X .375 X 3.000	4
5	56754	ROD-THREADED	1
6	56773	PIPE-PLASTIC	1
7	302911	PLATE-HEADSHAFT SLOT FILLER	2
8	302912	PLATE-HEADSHAFT BOGIE REPLACEMENT	2
9	303336	PLATE-SCRAPER	8
10	303335	PLATE-SCRAPER MOUNT RH	4
11	303338	PLATE-SCRAPER MOUNT LH	4
12	72063	BOLT-CRG: .63 X 1.50 NC GR5 ZP	16
13	1016595	NUT-TOPLOCK: .63 NC GR5 ZP	50
14	1032509	BOLT-HEX: .63 X 1.25 NC GR5 ZP	2
15	1011813	WASHER-LOCK: .63 ZP	2
16	1011607	BOLT-HEX: .50 X 1.50 NC GR5 ZP	10
17	1014443	WASHER-FLAT: .50 ZP	24
18	1027461	NUT-TOPLOCK: .50 NC GR5 ZP	22
19	59488	BOLT-CRG: .38 X 1.00 NC GR5 ZP	16
20	1016999	NUT-TOPLOCK: .38 NC GR5 ZP	24
21	1011828	WASHER-FLAT: .38 ZP	16
22	1011586	WASHER-LOCK: .38 ZP	16
23	1011576	NUT-HEX: .38 NC GR2 ZP	16
24	1016362	BOLT-CRG: .38 X 1.25 NC GR5 ZP	16

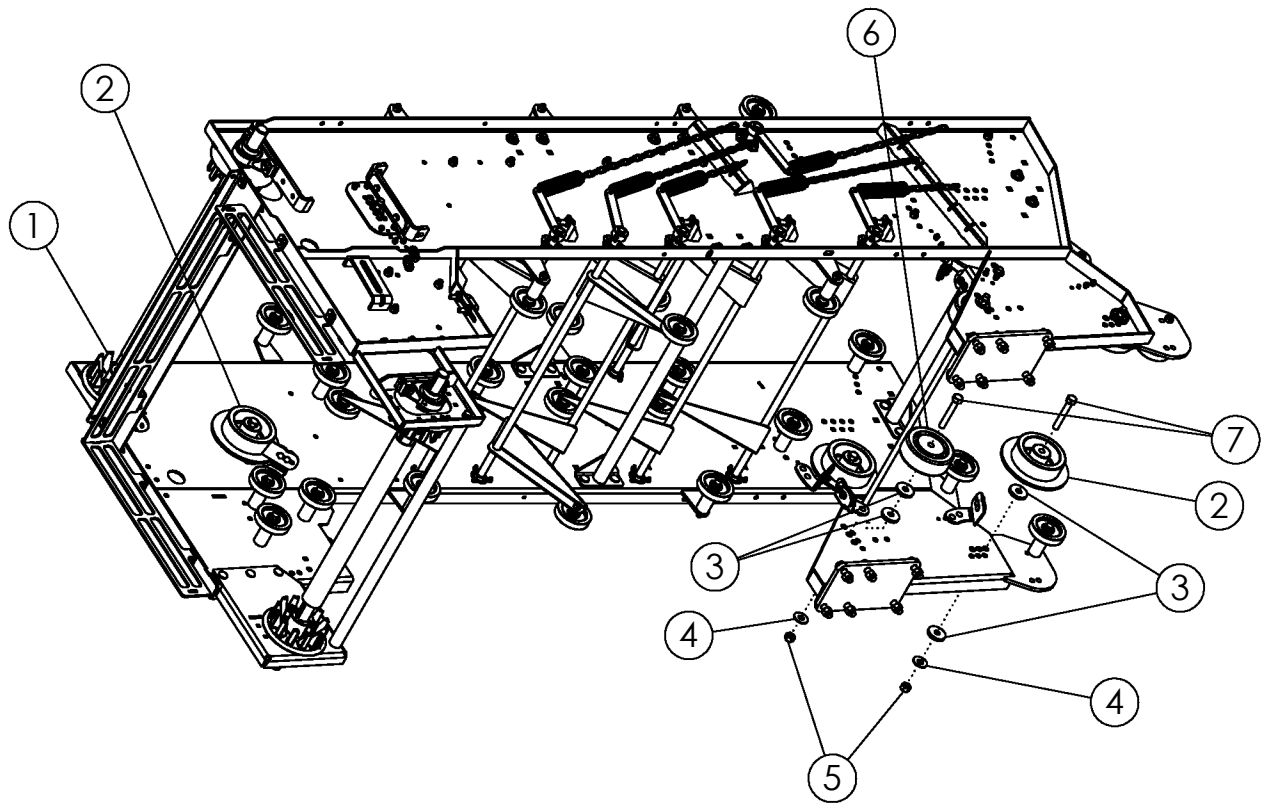
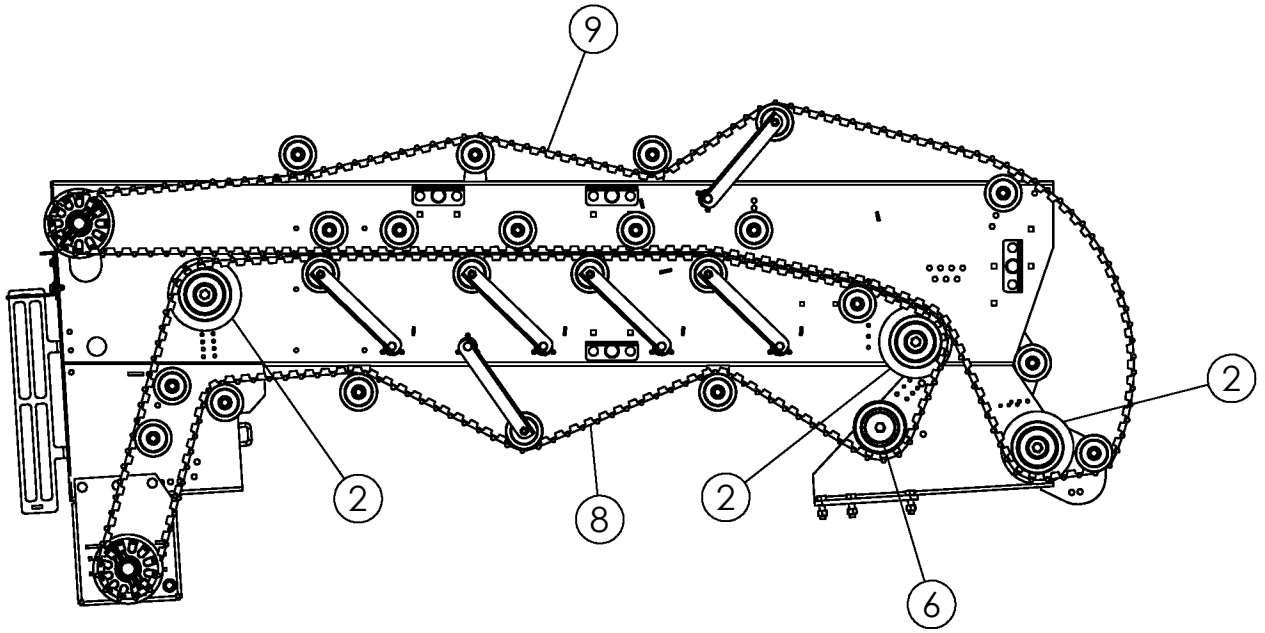

REAR SCRUB: G1 55MM BELTED CHAIN HP #302847

ITEM	PART NO.	DESCRIPTION	QTY
1	302873	SPROCKET-SPLIT 55MM 12T HP BELT DRIVE	4
2	310821	ROLLER-RUBBER LARGE FLANGE	6
3	303333	PLATE-FLANGE ROLLER SPACER	12
4	1030702	WASHER-FLAT: .75 ZP	8
5	1017000	NUT-TOPLOCK: .75 NC GR5 ZP	8
6	310822	ROLLER-RUBBER LARGE	2
7	58368	BOLT-HEX: .75 X 5.00 NC GR5 ZP	8
8	302871	BELT-55MM HIGH PROFILE INSIDE SCRUB G1	1
9	302872	BELT-55MM HIGH PROFILE OUTSIDE SCRUB G1	1

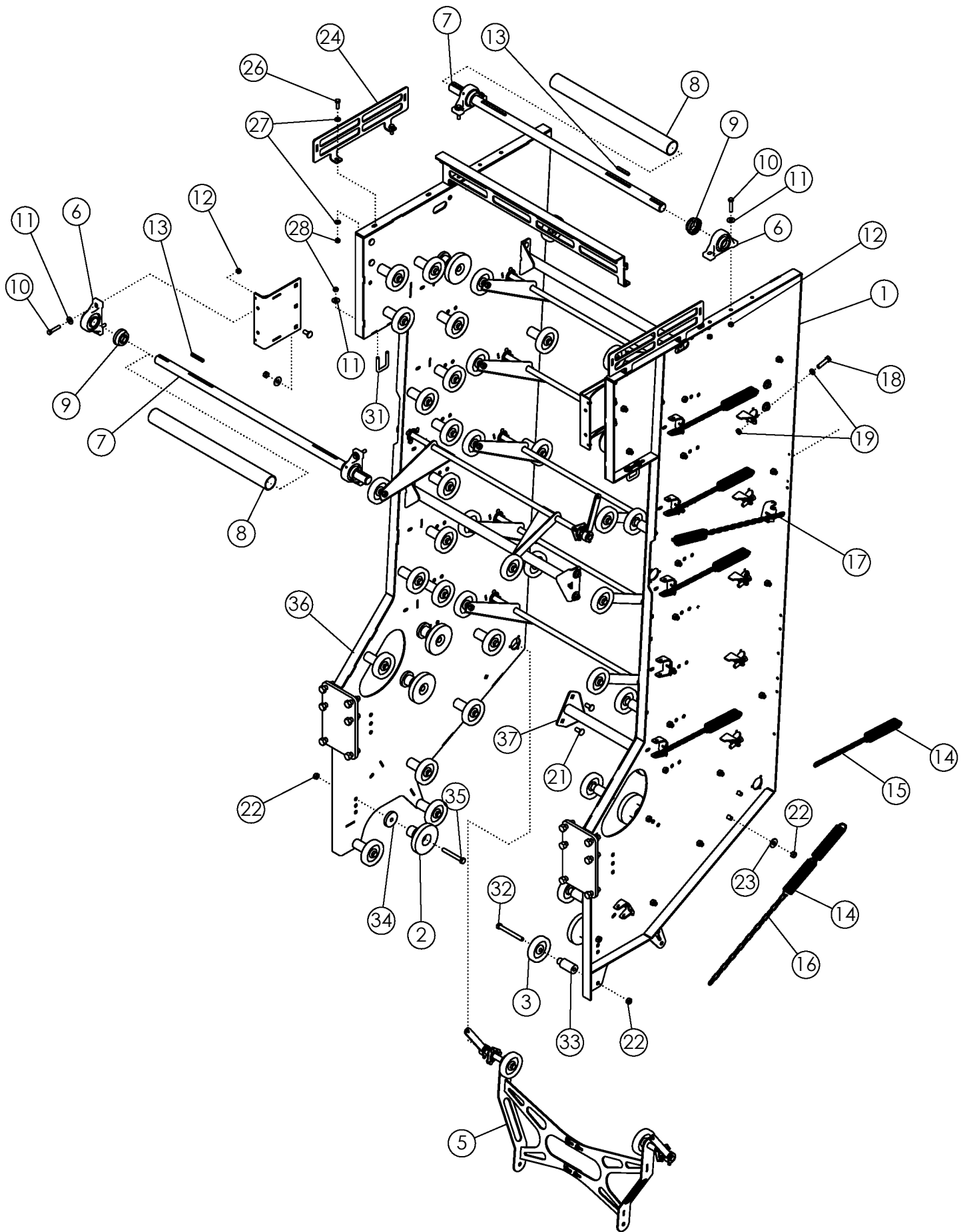

REAR SCRUB: G2 BELTED CHAIN ASSEMBLY

ITEM	PART NO.	DESCRIPTION	QTY
1	302608	WLDMT-REAR SCRUB PANEL G2 RH	1
2	54042	ROLLER-STEP 6" (LONG)	8
3	53825	BOGIE WHEEL 5"	40
4	302634	ASSY-SCRUB PENDULUM	6
5	302635	ASSY-SCRUB PENDULUM LARGE	1
6	52405	BEARING-PILLOW 1-3/4"	4
7	68650	SHAFT-HEAD Ø1.750	2
8	302402	PIPE-PLASTIC 6/8R SCRUB HEAD SHAFT	2
9	52382	SEAL PROTECTOR 1-3/4"	4
10	1011610	BOLT-HEX: .50 x 2.50 NC GR5 ZP	8
11	1014443	WASHER-FLAT: .50 ZP	12
12	1011577	NUT-HEX: .50 NC GR2 ZP	8
13	58201	KEY .375 X .375 X 3.000	4
14	53159	SPRING	16
15	302694	CHAIN-LINK: .188 X 14 LINKS	10
16	57938	CHAIN-LINK: .188 X 20.000	2
17	57939	CHAIN-LINK: .188 X 24.000	2
18	69390	BOLT-HEX: .63 X 2.50 NC GR5 ZP FULL	10
19	1026259	NUT-JAM: .63 NC GR2 ZP	20
20	302681	WLDMT-HEADSHAFT MOUNT	2
21	72063	BOLT-CRG: .63 X 1.50 NC GR5 ZP	18
22	1016595	NUT-TOPLOCK: .63 NC GR5 ZP	66
23	1013024	WASHER-FLAT: .63 ZP	18
24	302621	PLATE-SCRUB EXT SIDE	2
25	302620	PLATE-SCRUB EXT REAR	1
26	1011607	BOLT-HEX: .50 x 1.50 NC GR5 ZP	6
27	1011584	WASHER-FLAT: SAE .50 ZP	12
28	1027461	NUT-TOPLOCK: .50 NC GR5 ZP	10
29	1016598	BOLT- .75 X 2.50 NC GR5 ZP	12
30	1017000	NUT-TOPLOCK: .75 NC GR5 ZP	12
31	65658	U-BOLT: .50 X 3 X 2.06 X 3	2
32	1013068	BOLT-HEX: .63 X 6.00 NC GR5 ZP	40
33	64192	STAND OFF-.625 X 4.0"	40
34	62932	PLATE-SHIM .50 ZP	8
35	1013816	BOLT-HEX: .63 X 5.00 NC GR5 ZP	8
36	302609	WLDMT-REAR SCRUB PANEL G2 LH	1
37	300403	WLDMT-CROSS TUBB	3

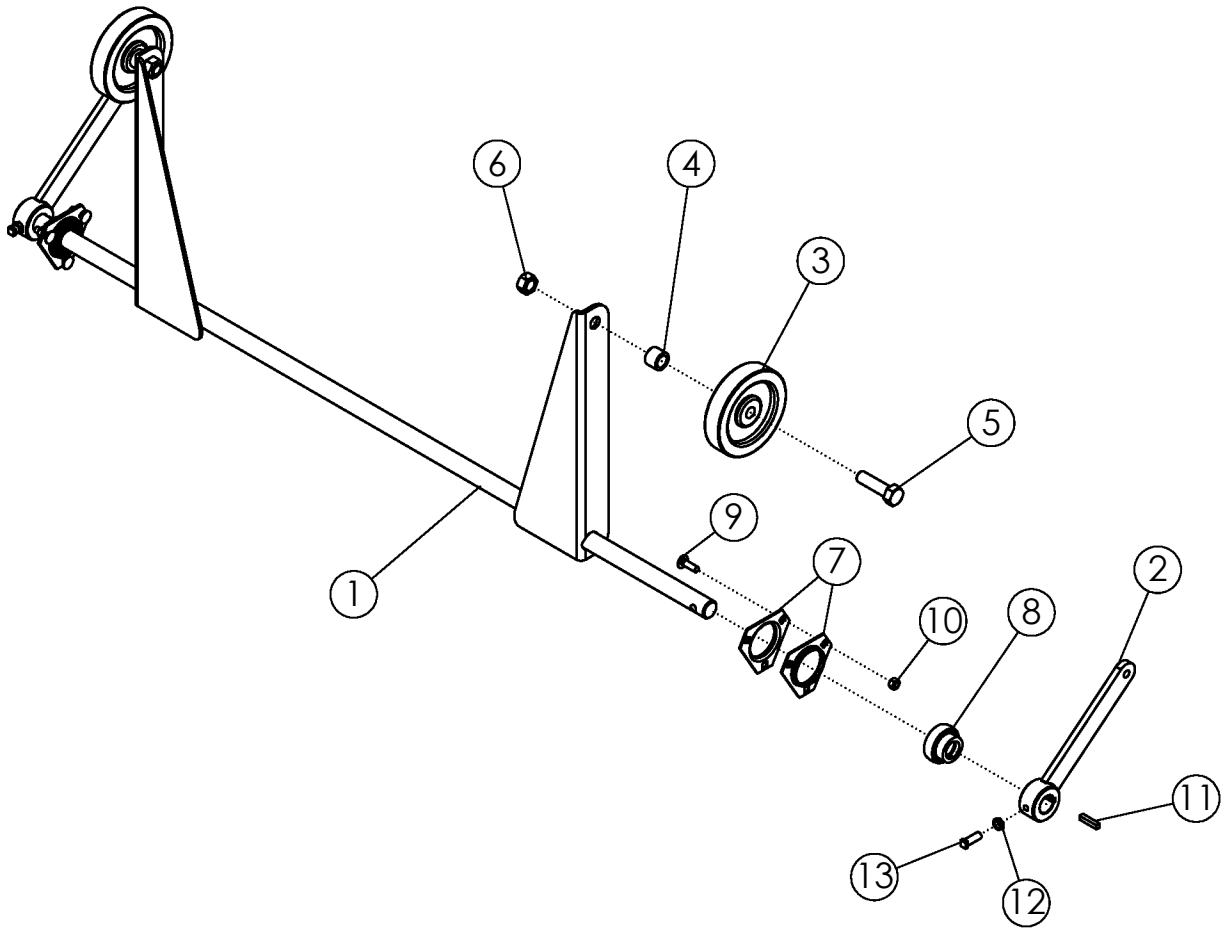

ASSY-SCRUB PENDULUM

ITEM	PART NO.	DESCRIPTION	QTY
1	53401	WLDMT-PENDULUM	1
2	50718	ARM-ZP	2
3	53825	BOGIE WHEEL 5"	2
4	64253	SPACER ZP	2
5	1017526	BOLT-HEX .63 X 2.25 NC GR5 ZP	2
6	1016595	NUT-TOPLOCK: .63 NC GR5 ZP	2
7	53945	TRIANGLE FLANGETTE	4
8	53944	BEARING-INSERT 1" WTH LOCKING COLLAR	2
9	1017255	BOLT-CRG: .31 X 1.00	6
10	1030700	NUT-TOPLOCK: .31 NC GR5 ZP	6
11	1012975	KEY .250 X .250 X 1.250	2
12	1013519	NUT-JAM: .38 NC GR2 ZP	2
13	50813	SCREW-SET: SQ HD .38 X 1.00 ZP	2

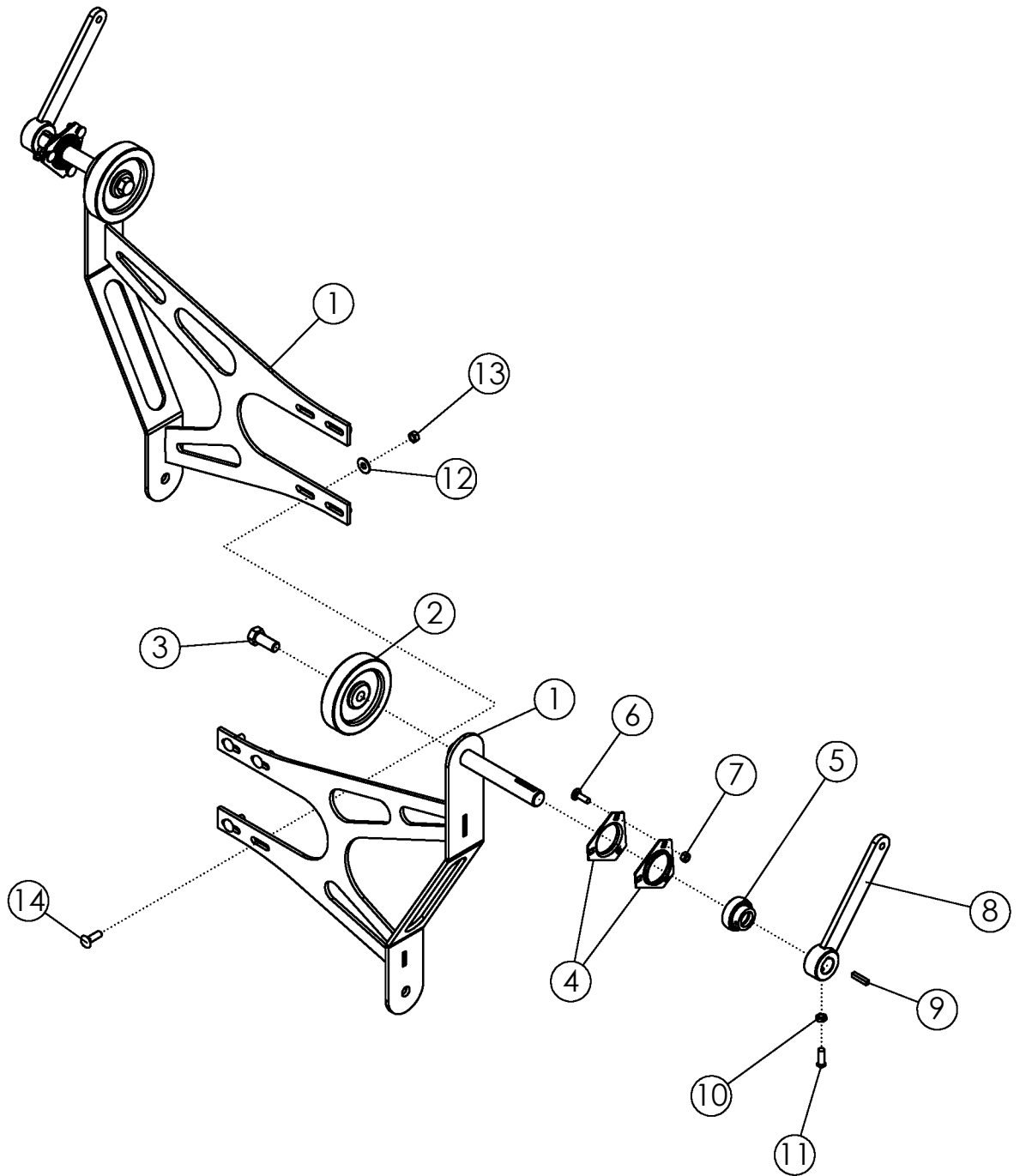

ASSY-SCRUB PENDULUM LARGE

ITEM	PART NO.	DESCRIPTION	QTY
1	302636	WLDMT-SCRUB PENDULUM LARGE	2
2	53825	BOGIE WHEEL 5"	2
3	1014349	BOLT-HEX: .63 X 1.50 NC GR5 ZP	2
4	53945	1016353 TRIANGLE FLANGETTE	4
5	53944	7367-2 BEARING-INSERT 1"	2
6	1017255	BOLT-CRG: .31 X 1.00 NC GR5 ZP	6
7	1030700	NUT-TOPLOCK: .31 NC GR5 ZP	6
8	50718	ARM-ZP	2
9	1012975	KEY .250 X .250 X 1.250	2
10	1013519	NUT-JAM: .38 NC GR2 ZP	2
11	50813	SCREW-SET: SQ HD .38 X 1.00 ZP	2
12	1016362	BOLT-CRG: .38 X 1.25 NC GR5 ZP	4
13	1011828	WASHER-FLAT: .38 ZP	4
14	1016999	NUT-TOPLOCK: .38 NC GR5 ZP	4

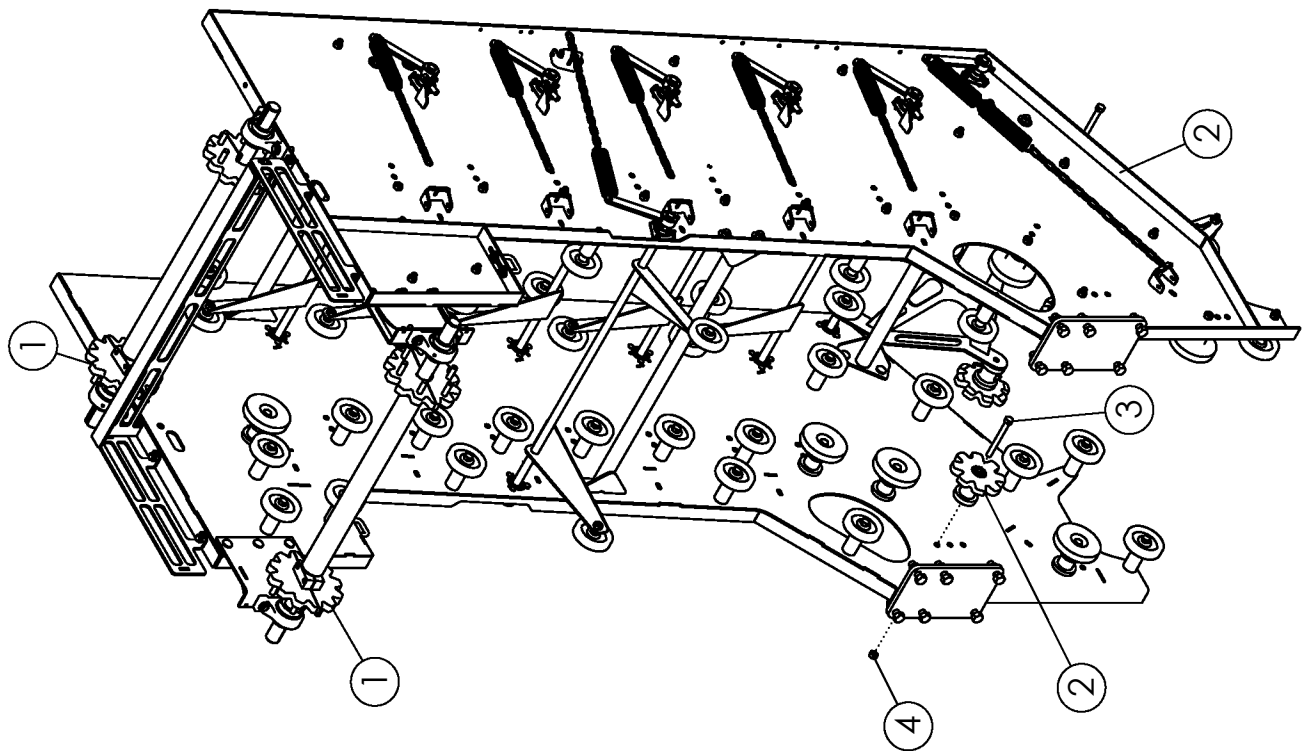
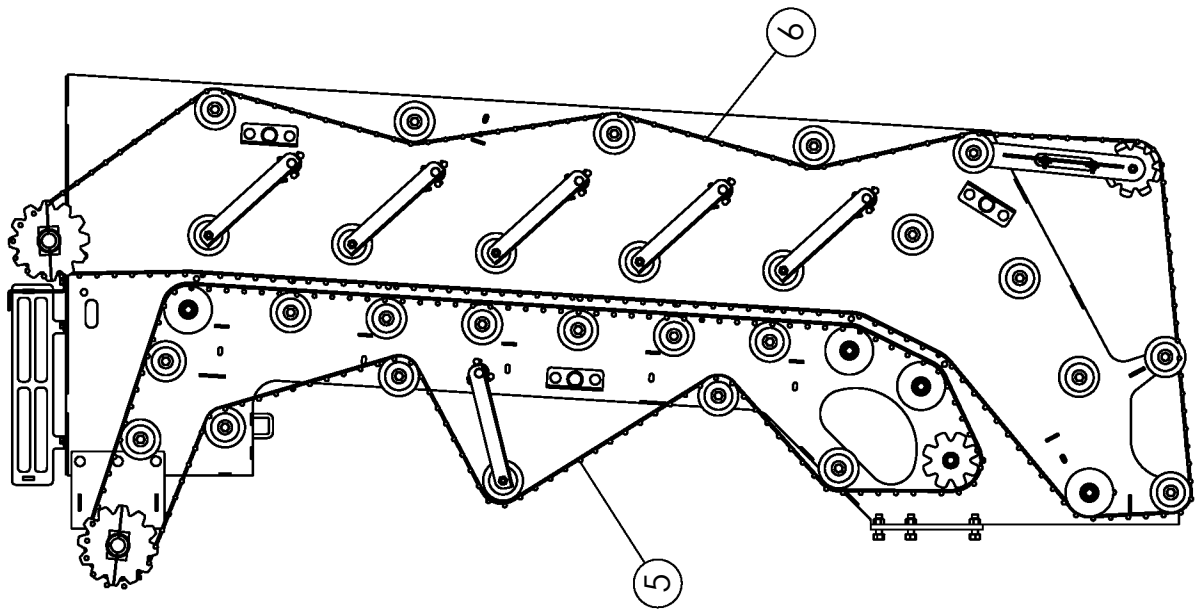

BELTED CHAIN 50MM/56MM G2 SCRUB

ITEM	PART NO.	DESCRIPTION	QTY
1	68651	SPROCKET-SPLIT 56MM	4
	68657	SPROCKET-SPLIT 50MM 14T ϕ 1.750	
2	54824	SPROCKET-IDLER 56MM	4
	63813	SPROCKET-IDLER 50MM 10T	
3	1013068	BOLT-HEX: .63 X6.00 NC GR5 ZP	4
4	1016595	NUT-TOPLOCK: .63 NC GR5 ZP	4
5	302719	BELT-56MM INSIDE SCRUB 6R/8R G2	1
	302720	BELT-50MM INSIDE SCRUB 6R/8R G2	
6	302605	BELT-56MM OUTSIDE SCRUB 6R/8R G2	1
	302721	BELT-50MM OUTSIDE SCRUB 6R/8R G2	

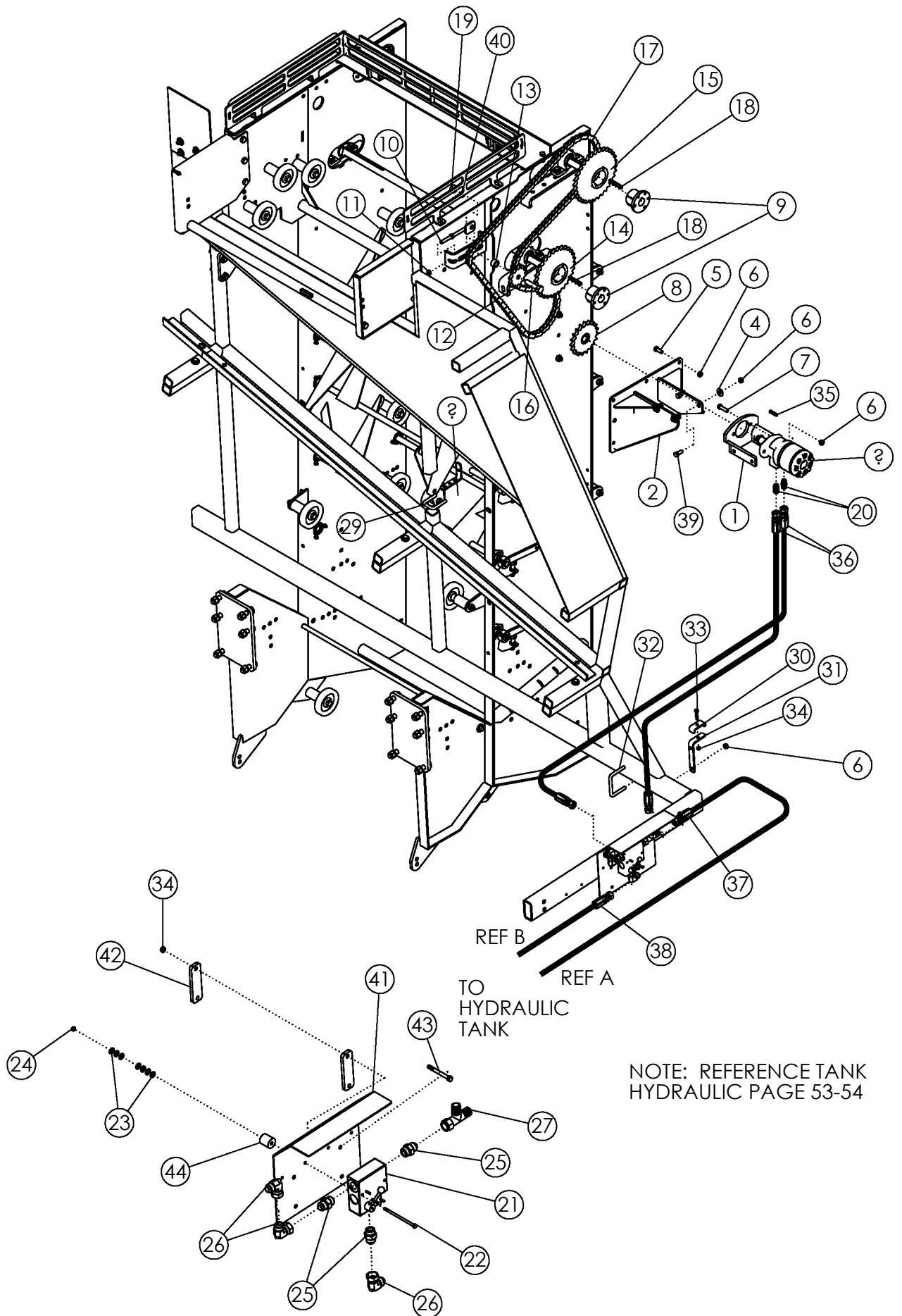

REAR SCRUB DRIVE: SINGLE MOTOR

ITEM	PART NO.	DESCRIPTION	QTY
1	58102	WLDMT-MOTOR BRACKET	1
2	62103	WLDMT-GEARBOX MOUNT	1
3	58987	MOTOR-HYDRAULIC 20.6IN^3/REV	1
	57880	SEAL KIT FOR 58387	
4	1014443	WASHER-FLAT: .50 ZP	4
5	1011606	BOLT-HEX: .50 X 1.25 NC GR5 ZP	5
6	1027461	NUT-TOPLOCK: .50 NC GR5 ZP	17
7	1011608	BOLT-HEX: .50 X 1.75 NC GR5 ZP	2
8	62125	SPROCKET-8019X 1.25 BORE .313 KEY	1
9	50335	HUB Q1 1.75	2
10	63876	TENSIONER ZP	1
11	1011577	NUT-HEX: .50 NC GR2 ZP	2
12	56334	SPROCKET-IDLER 8012	1
13	58086	SPACER-CHAIN IDLER ZP	1
14	59051	SPROCKET H80-Q30	1
15	59052	SPROCKET H80-Q32	1
16	1012059	BOLT-HEX: .75 X 3.00 NC GR5 ZP	1
17	68784	CHAIN-ROLLER 80-1R-114	1
18	50152	KEY .38 X .38 X 2.00	2
19	1011620	NUT-HEX: .75 NC GR2 ZP	1
20	59043	FTG-ADAPTER: 10MB-12MJ	2
21	58985	VALVE-FLOW CONTROL- 3/4" FP	1
	64414	SEAL KIT FOR 58985	
22	1030766	BOLT-HEX: .25 X 4.00 NC GR5 ZP	2
23	1020416	WASHER-FLAT: .25 ZP	14
24	1030946	NUT-TOPLOCK: .25 NC GR5 ZP	2
25	59042	FTG-ADAPTER: 12MP-12MJ	3
26	59041	FTG-ELBOW: 12MJ-12FJX-90	3
27	59888	FTG-TEE: 12MJ-12FJX-12MJ	1
28	59184	BRACKET-HOSE ZP	1
29	65658	U-BOLT: .50 X 3.00 X 2.06 X 3.00	1
30	63753	CLAMP .75 ZP	3
31	59182	BRACKET-HOSE ZP	2
32	54653	U-BOLT: .50 X 3.25 X 4.00 X 3.25	2
33	1011725	BOLT-HEX: .38 X 2.00 NC GR5 ZP	3
34	1016999	NUT-TOPLOCK: .38 NC GR5 ZP	7
35	58396	KEY .313 X .313 X 1.750	1
36	59895	HOSE: .75 X 173 12FJX-12FJX (8R-FRAME)	2
	59036	HOSE: .75 X 152 12FJX-12FJX (6R-FRAME)	
37	59801	HOSE: .75 X 74 12FJX-12FJX	1
38	59035	HOSE: .75 X 66 12FJX-12FJX	1

CONTINUE

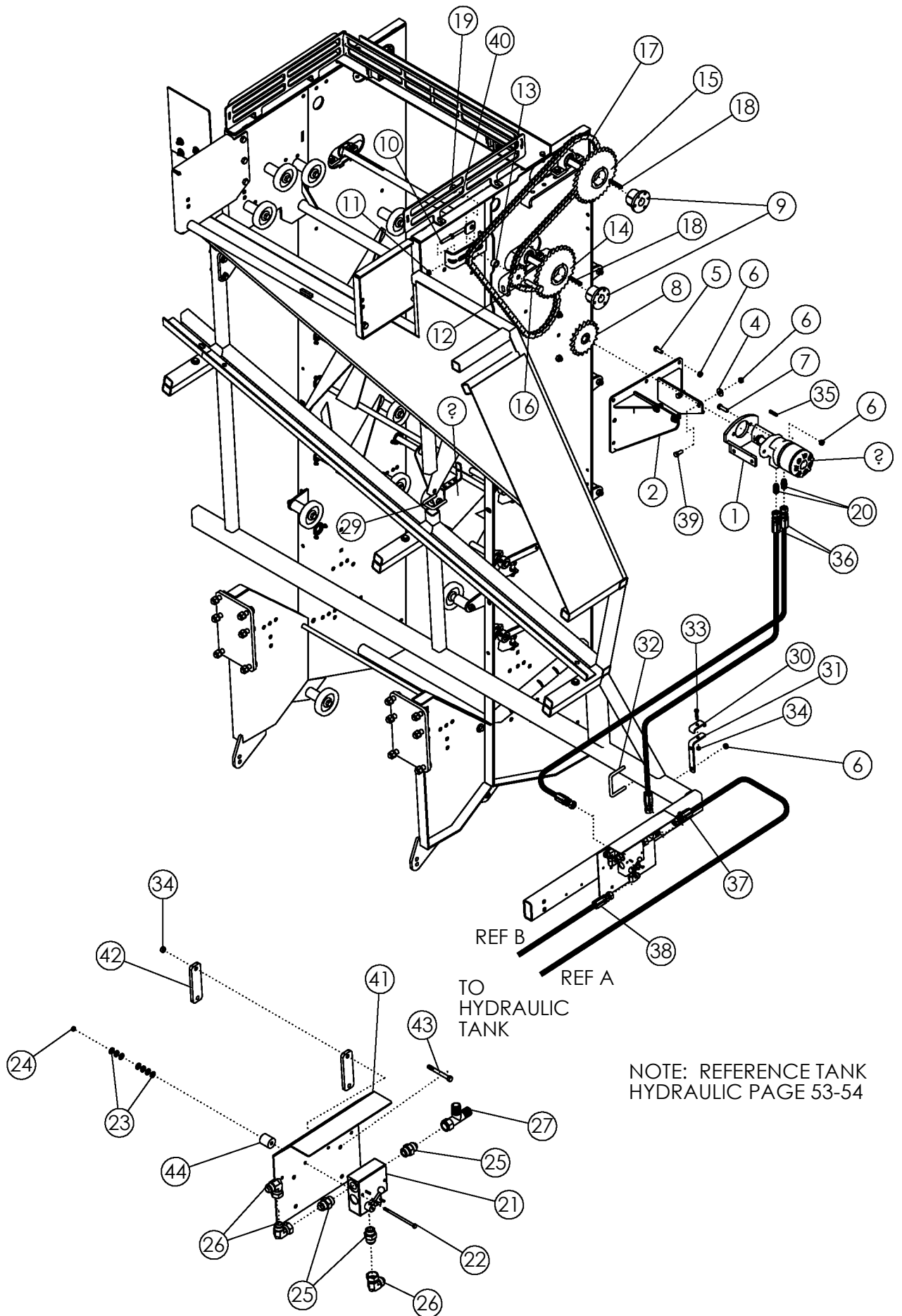

REAR SCRUB DRIVE: SINGLE MOTOR (CONTINUED)

ITEM	PART NO.	DESCRIPTION	QTY
39	1011607	BOLT-HEX: .50 X 1.50 NC GR5 ZP	4
40	1012061	WASHER-LOCK: .75 ZP	1
41	69020	WLDMT-BRACKET FLOW CONTROL	1
42	59881	BRACKET-BOLT PLATE	4
43	58176	BOLT-HEX: .38 X 3.50 NC GR5 ZP	4
44	59463	SPACER ZP	2

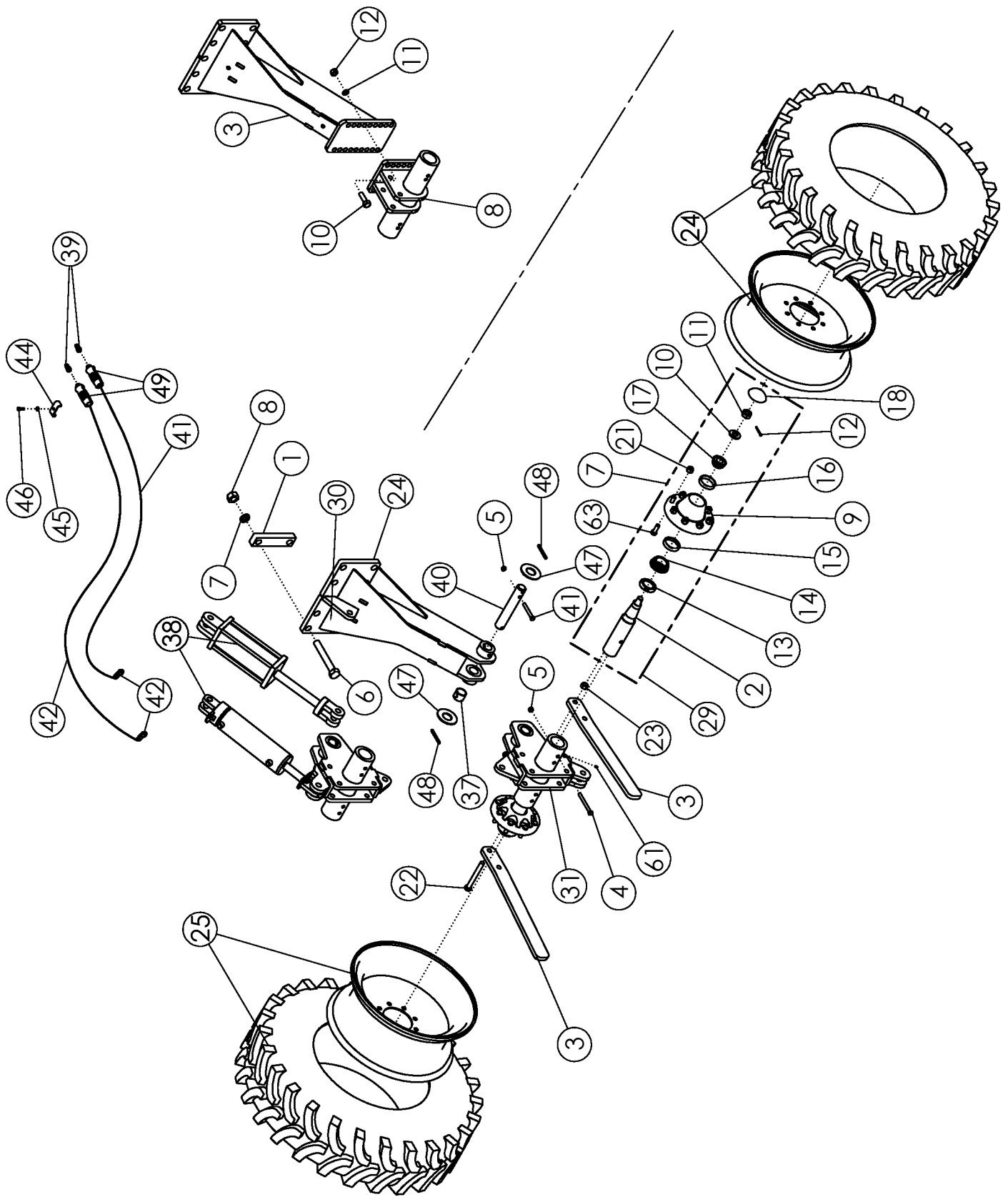

STANDARD REAR STRUTS 11.2 X 24

ITEM	PART NO.	DESCRIPTION	QTY
1	300135	WLDMT-MOUNT ADJ 11.2-24 UNIVERSAL	2
2	69204	WLDMT-STRUT LH ADJ 11.2 X24	2
3	64143	BAR - BOLTING	4
4	52954*	SPINDLE-STANDARD	1
5	59045	SCRAPER	2
6	54393*	7600-6 STUD-HUB BOLT	8
7	301490	SELF TAPPING GREASE FITTING	1
8	1011748	ZERK-GREASE: .25 UNF STRAIGHT	1
9	1011618	BOLT-HEX: .50 X5.00 NC GR5 ZP	2
10	1027461	NUT-TOPLOCK: .50 NC GR5 ZP	10
11	64145	BOLT-HEX: 1.13 X8.00 NC GR8 ZP	8
12	64147	WASHER-LOCK: 1.13 ZP	8
13	64146	NUT-HEX: 1.13 NC GR2 ZP	8
14	53623*	HUB-WHEEL 8 BOLT	1
15	1030728*	WASHER-SPINDLE: 1.06ID X 2.13OD	1
16	1030726*	NUT-SPINDLE: 1.00 NF NP	1
17	1030797*	PIN-COTTER: .19 X 1.75 NP	1
18	53619*	SEAL	1
19	53621*	BEARING CONE-INNER	1
20	53622*	BEARING CUP-INNER	1
21	52243*	BEARING CUP-OUTER	1
22	53620*	BEARING CONE-OUTER	1
23	53624*	HUB CAP	1
24	56986	TIRE-MNTD: 11.2-24 10 PLY R1 RH	1
	56903	WHEEL W10 X 24 8 BOLT (1.88 POS)	
	56976	TIRE 11.2-24 10 PLY R1	
	68973	TUBE-REPAIR 11.2-24	
25	63992	TIRE-MNTD: 11.2-24 10 PLY R1 LH	1
	56903	WHEEL W10 X 24 8 BOLT (1.88 POS)	
	56976	TIRE 11.2-24 10 PLY R1	
	68973	TUBE-REPAIR 11.2-24	AR
26	53625*	NUT-WHEEL: .63-18NF	8
27	1016718	BOLT-HEX: .75 X6.50 NC GR5 ZP	2
28	1017000	NUT-TOPLOCK: .75 NC GR5 ZP	2
29	53167	ASSY-HUB & SPINDLE 8-BOLT	2
30	52248	DECAL-CAUTION	1
31	73368	WASHER-FLAT: 1.75 ZP	2
32	73369	ROLL PIN: .38 X3.50 ZP	2
33	301238	PIN-STRUT REAR ADJ	1
34	1032524	BOLT-HEX: .50 X 4.00 NC GR5 ZP	1

CONTINUE

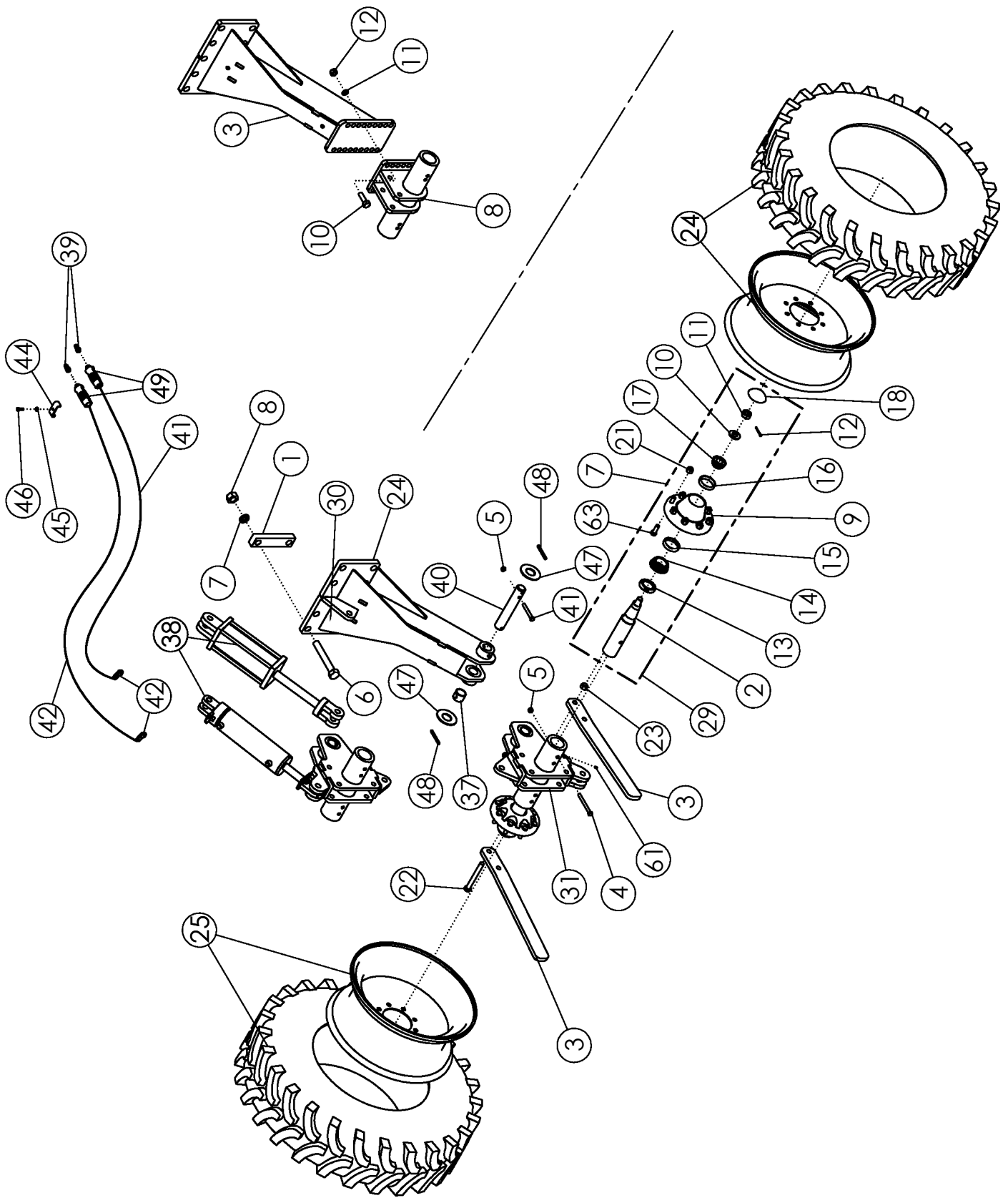

STANDARD REAR STRUTS (CONTINUED)			
ITEM	PART NO.	DESCRIPTION	QTY
35	72950	CYLINDER-HYDRAULIC 4 X 10	1
	301315	SEAL KT-CYL 4 X 8, 4 X 10 3000PSI UNIVERSAL	
	73421	CYLINDER-HYD 4 X 10-3000-0° ADC	
	73629	SEAL KIT FOR 73421	
36	50714	CLAMP .50 ZP	6
37	1011586	WASHER-LOCK: .38 ZP	6
38	1011600	BOLT-HEX: .38 X 1.00 NC GR5 ZP	6
39	36290	PIONEER TIP 8010-15P (#8 ORB)	2
40	58560	FTG-ELBOW: 8MB-8MJ-90	2
41	66596	HOSE: .50 X 320 8FJX-8MB	1
42	67670	HOSE: .50 X 312 8MB-8FJX	1
43	301237	BUSHING-SPRING 2.00 X 1.75 X 1.50	2
44	69206**	WLDMT-STRUT RH STD 11.2-24	1
45	302551**	WLDMT-UNIVERSAL SPINDLE MOUNT	1
46	1016598**	BOLT-HEX: .75 X 2.50 NC GR5 ZP	6
47	1012061**	WASHER-LOCK: .75 ZP	6
48	1011620**	NUT-HEX: .75 NC GR2 ZP	6
49	302227	HYD LABEL: .50 BLUE/YELLOW SET (LH SIDE)	1
	302230	HYD LABEL: .50 RED/GREEN SET (RH SIDE)	1

* ITEMS INCLUDED IN ITEM 29

** ITEMS ARE INCLUDED ONLY IN STANDARD STRUT OPTION

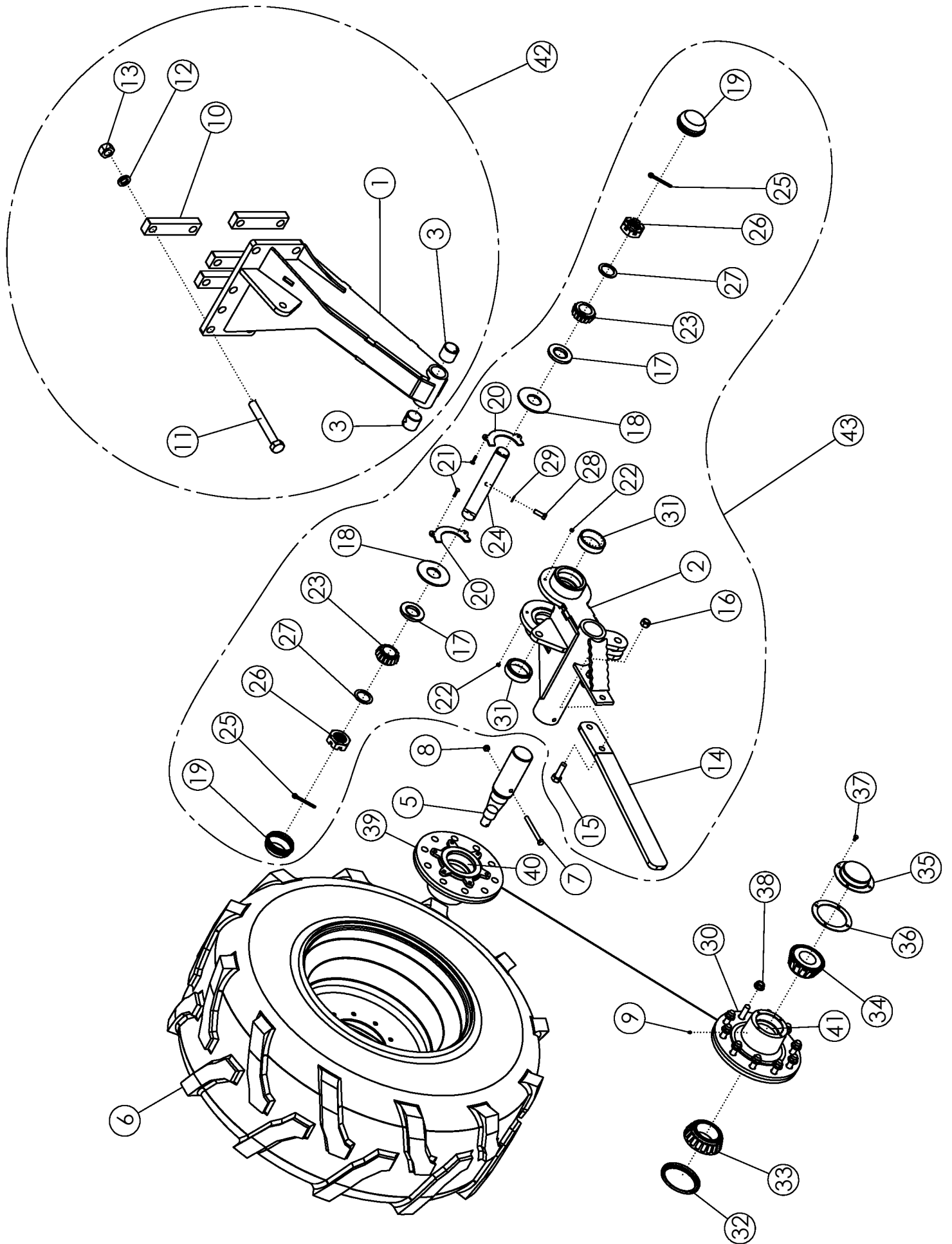

REAR STRUT STD ADJ 23.5/55-26

ITEM	PART NO.	DESCRIPTION	QTY
1	73445	WLDMT-STRUT LH UPPER 23.5	1
	73469	WLDMT-STRUT RH UPPER 23.5 (NOT SHOWN)	1
2	301807	ASSY-STRUT LH LOWER W/CUPS PAINTED	1
	301808	ASSY-STRUT RH LOWER W/CUPS PAINTED (NS)	1
3	73466	BUSHING-SPRING 2.25 X 2.0 X 2.0 L (REF)	2
4	73369	PIN-ROLL: .38 X 3.50 ZP	1
5	35519-1*	ASSY-SPINDLE: 3.13 X 14.5 CRS	1
6	35343	ASSY-LH TIRE & WHEEL 23.5/55-26	1
	35344	ASSY-RH TIRE & WHEEL 23.5/55-26 (NOT SHOWN)	1
	35345	TIRE 23.5/55-26	1
	35346	WHEEL 26X20 WIDE 10 BOLT (SILVER)	1
7	1011618	BOLT-HEX: .50 X 5.00 NC GR5 ZP	1
8	1027461	NUT-TOPLOCK: .50 NC GR5 ZP	1
9	1011748*	ZERK - GREASE	2
10	64143	BAR - BOLTING	4
11	64145	BOLT-HEX: 1.125 X 8.00 NC GR8 ZP	8
12	64147	WASHER-LOCK: 1.125 ZP	8
13	64146	NUT-HEX: 1.125 NC GR2 ZP	8
14	59045	SCRAPER	1
15	1016598	BOLT- .75 X 2.50 NC GR5 ZP	2
16	1017000	NUT-TOPLOCK: .75 NC GR5 ZP	2
17	301683	SEAL-SINGLE TIRE STRUT	2
18	301677	SEAL CAP 8R LOWER STRUT 23.5 ADC	2
19	301672	HUB CAP	2
20	301803	PLATE-SEAL CAP CLAMP	2
21	301804	BOLT-CRG: .25 X 1.25 NC GR5 ZP	4
22	1030946	NUT-TOPLOCK: .25 NC GR5 ZP	4
23	301673	BEARING CUP-INNER (TIMKEN 529)	2
24	301678	PIN-STRUT REAR ADJ 23.5 ADC W/BEARINGS HARDENED	1
25	301682	PIN-COTTER: .313 X 3.5 ZP	2
26	301685	NUT-HEX: SLOT 2.00 UN GR2 NP	2
27	301679	WASHER-FLAT: 2.00 X 2.75 X .125	2
28	1011607	BOLT-HEX: .50 X 1.50 NC GR5 ZP	1
29	1011581	WASHER-LOCK: .50 ZP	1
30	35519-2*	ASSY-HUB 10 BOLT-11.25 BC-12000#	1
31	301674	BEARING CUP-OUTER (TIMKEN 520X)	2
32	320143*	SEAL- OIL	1
33	320144*	BEARING-CONE OUTER	1
34	320145*	BEARING-CONE INNER	1
35	320146*	CAP-HUB	1
36	320148*	GASKET-CAP HUB	1
37	1011596*	BOLT-HEX: .31 X .50 NC GR5 ZP	4
38	320147*	NUT-WHEEL	10
39	35519	ASSY-HUB&SPINDLE: 10-BOLT 12000#	1
40	320140*	BEARING CUP-INNER	2
41	320141*	BEARING CUP-OUTER	2
42	303779	ASSY-SINGLE STRUT 23.5 UPPER LH	1
	303780	ASSY-SINGLE STRUT 23.5 UPPER RH	1
43	303781	ASSY-SINGLE STRUT 23.5 LOWER (LH - NON-ADC -- RH - ADC)	1
	303782	ASSY-SINGLE STRUT 23.5 LOWER (RH - NON-ADC -- LH - ADC)	1

* ITEMS INCLUDED IN ITEM 39

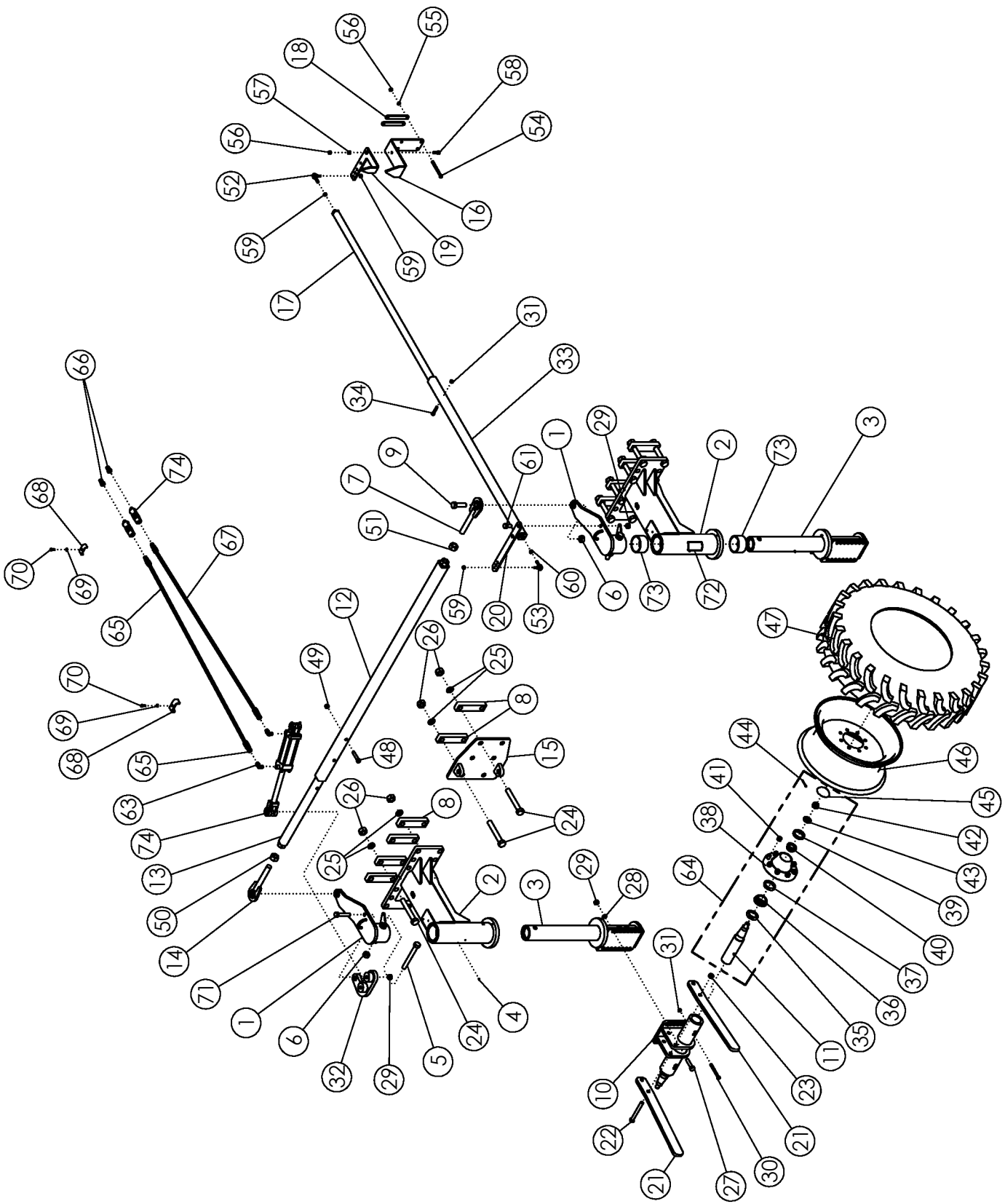

STEERABLE REAR STRUTS

ITEM	PART NO.	DESCRIPTION	QTY
1	58240	WLDMT - STEERING ARM	2
2	58285	WLDMT-STEERING HOUSING R.H.	1
3	58238	WLDMT - KING PIN	2
4	1011748	ZERK - GREASE	10
5	1033376	BOLT-HEX: 1.0 x 8.50 NC GR8 ZP	2
6	1016969	NUT-TOPLOCK: 1.00 NC GR5 ZP	4
7	58186	WLDMT-TIE ROD RH	1
8	64143	BAR - BOLTING	6
9	1032276	BOLT-HEX: 1.0 x 3.50 NC GR8 ZP	2
10	57233	WLDMT - MOUNT STANDARD	2
11	52954	SPINDLE-STANDARD	4
12	58374	WLDMT-TIE ROD EXTENSION	1
13	58341	WLDMT-TIE ROD	1
14	58203	WLDMT-TIE ROD LH	1
15	58239	WLDMT-STEERING HOUSING LH	1
16	53278	MOUNT-INDICATOR	1
17	59492	*ASSY DESC.*	1
18	56809	BAR-BOLTING	2
19	58348	INDICATOR	1
20	58346	ARM-STEERING INDICATOR	1
21	59045	SCRAPER	4
22	1012059	BOLT-HEX: .75 X 6.50 NC GR5 ZP	4
23	1017000	NUT-TOPLOCK .75 NC GR5 ZP	4
24	64145	BOLT-HEX: 1.125 X 8.00 NC GR8 ZP	12
25	64147	WASHER-LOCK: 1.125 ZP	12
26	64146	NUT-HEX: 1.125 NC GR2 ZP	12
27	1012059	BOLT- .75 X 3.00 NC GR5 ZP	12
28	1012061	WASHER-LOCK: .75 ZP	12
29	1011620	NUT: .750 NC	15
30	1011618	BOLT-HEX: .50 X 5.00 NC GR5 ZP	4
31	1027461	NUT-TOPLOCK: .50 NC GR5 ZP	5
32	58123	PLATE	1
33	59493	WLDMT-TIE ROD EXTENSION	1
34	1011610	BOLT-HEX: .50 x 2.50 NC GR5 ZP	1
35	53619	SEAL	4
36	53621	CONE-BEARING	4
37	53622	CUP-BEARING INNER	4
38	53623	HUB-WHEEL 8 BOLT	4
39	52243	BEARING CUP	4
40	53620*	BEARING-CONE	4

CONTINUED

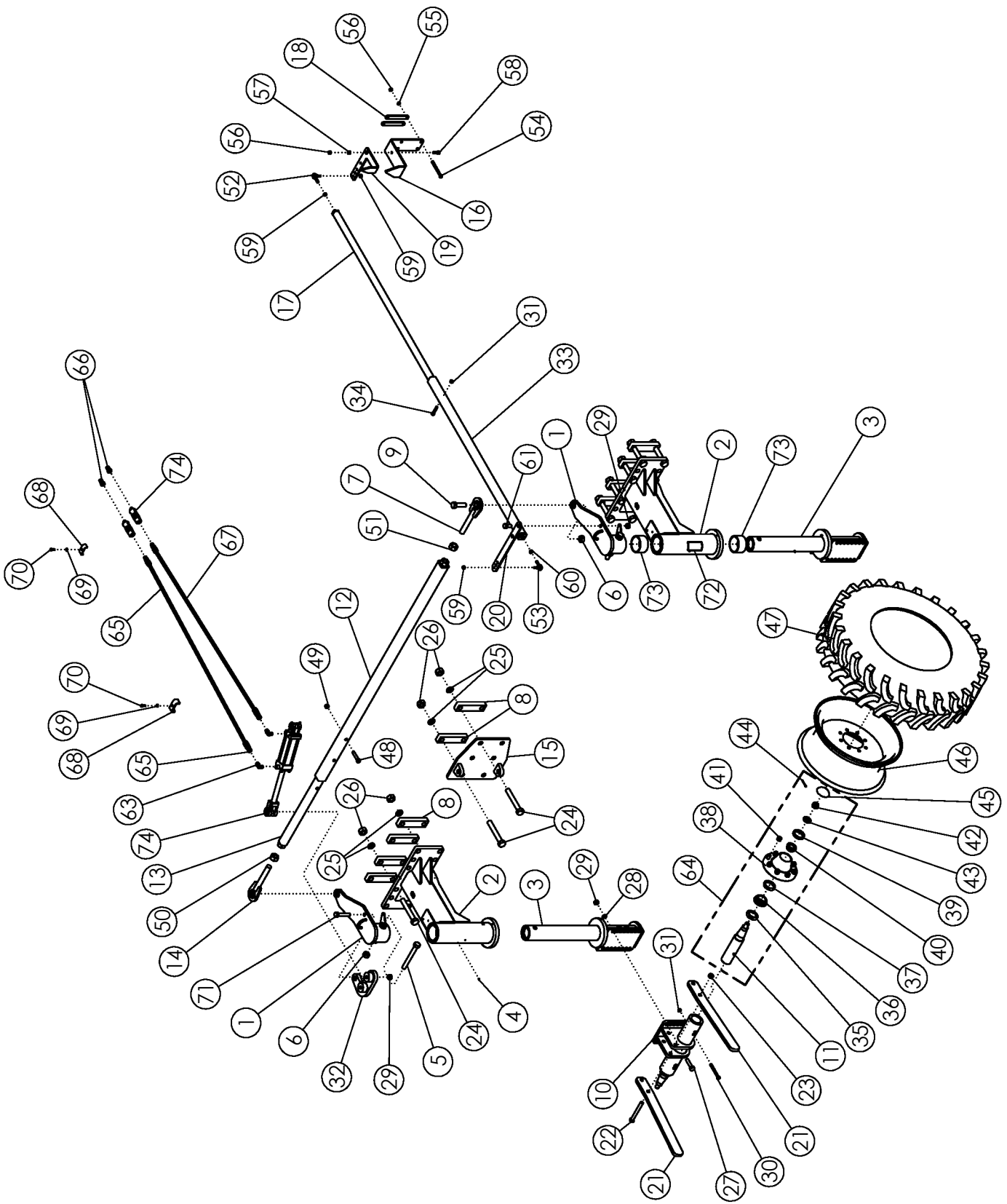

STEERABLE REAR STRUTS (CONTINUED)			
ITEM	PART NO.	DESCRIPTION	QTY
41	53625*	NUT-WHEEL: .63-18NF	32
42	1030726*	NUT-SPINDLE: 1.00 NF NP	4
43	1030728*	WASHER-SPINDLE: 1.06ID X 2.13OD	4
44	1030797*	PIN-COTTER: .19 X 1.75 NP	4
45	53624*	HUB CAP	4
46	56903	WHEEL W10 X 24 8 BOLT (1.875 POS)	4
47	56976	TIRE 11.2-24 10 PLY R1	4
	68973	TUBE-REPAIR 11.2-24 (NOT SHOWN)	AR
48	1030704	BOLT-HEX: .63 X 3.25 NC GR5 ZP	1
49	1011578	NUT-HEX: .63 NC GR2 ZP	1
50	1030729	NUT-HEX: 1.25 NC GR2 ZP LH	1
51	1011621	NUT-HEX: 1.25 NC GR2 ZP	1
52	58350	BALL JOINT ROD END 1/2-20NF RH	1
53	58351	BALL JOINT ROD END 1/2-20NF LH	1
54	1016660	BOLT-HEX: .50 X 5.50 NC GR5 ZP	4
55	1011581	WASHER-LOCK: .50 ZP	4
56	1011577	NUT-HEX: .50 NC GR2 ZP	5
57	56884	BUSHING-INDICATOR REAR STRUT	1
58	1011607	BOLT-HEX: .50 X 1.50 NC GR5 ZP	1
59	58355	NUT-HEX: .50 NF GR5 ZP RH	3
60	58366	NUT-HEX: .50 NF GR5 ZP LH	1
61	58367	BOLT-HEX: .75 X 1.50 NC GR5 ZP	2
62	58890	CYLINDER HYDRAULIC 3 X 8	1
	301314	SEAL KIT FOR 58890 UNIVERSAL	
63	58560	FTG-ELBOW: 8MB-8MJ-90	2
64	53167	ASSY-HUB & SPINDLE 8 BOLT	2
65	300029	HOSE: .50 X 276 8MB-8FJX	1
66	36290	PIONEER TIP 8010-15P (#8 ORB)	2
67	66604	HOSE: .50 X 290 8FJX-8MB	1
68	50714	CLAMP 1/2" ZP	4
69	1011586	WASHER-LOCK: .38 ZP	4
70	1011600	BOLT-HEX: .38 X 1.00 NC GR5 ZP	4
71	1011625	BOLT-HEX: .75 X 4.00 NC GR5 ZP	2
72	52248	DECAL CAUTION	1
73	59205	BUSHING-BORED 4.5 X 4.025	4
74	301908	HYD LABEL: .50 RED/GRAY SET	1

* Items are included in Item 64

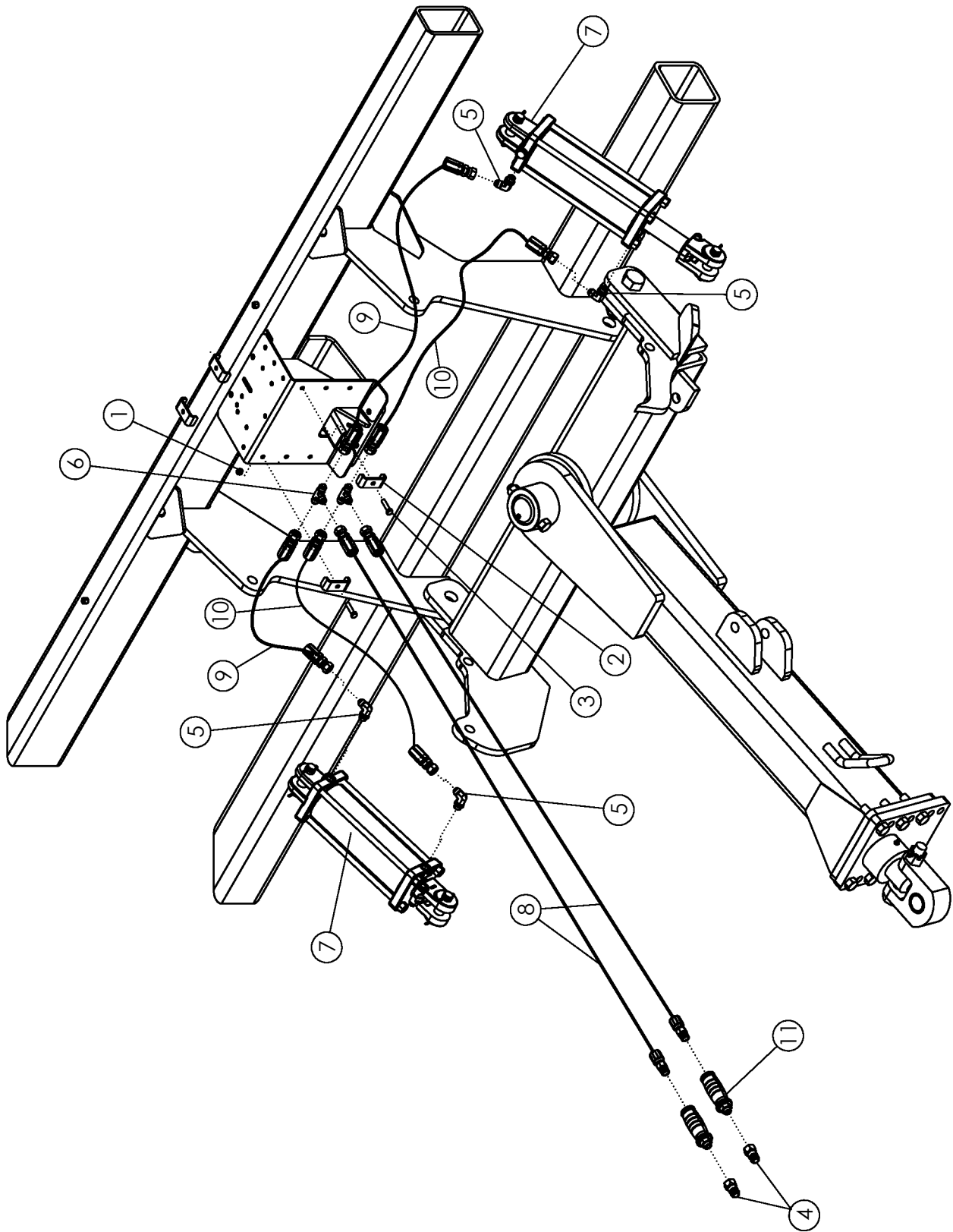

HITCH HYDRAULICS

ITEM	PART NO.	DESCRIPTION	QTY
1	1016999	NUT-TOPLOCK: .38 NC GR5 ZP	6
2	50714	CLAMP .50 ZP	6
3	1011602	BOLT-HEX: .38 X 1.50 NC GR5 ZP	6
4	36290	PIONEER TIP 8010-15P (#8 ORB)	2
5	58560	FTG-ELBOW: 8MB-8MJ-90	4
6	57667	FTG-TEE: 8MJ-8MJ-8MJ	2
7	62082	CYLINDER-HYDRAULIC 4 X 10" 3000	2
	301315	SEAL KIT FOR 62082 UNIVERSAL	
8	37705	HOSE: .50 X 128 8FJX-8MB	2
	301647	HOSE: .50 X 143 8MB-8FJX	2
9	57676	HOSE: .50 X 031 8FJX-8FJX	2
	1015221	HOSE: .50 X 040 8FJX-8FJX	2
10	301105	HOSE: .50 X 043 8FJX-8FJX	2
	35770	HOSE: .50 X 052 8FJX-8FJX	2
11	301911	HYD LABEL: .50 BLACK/GRAY SET	1

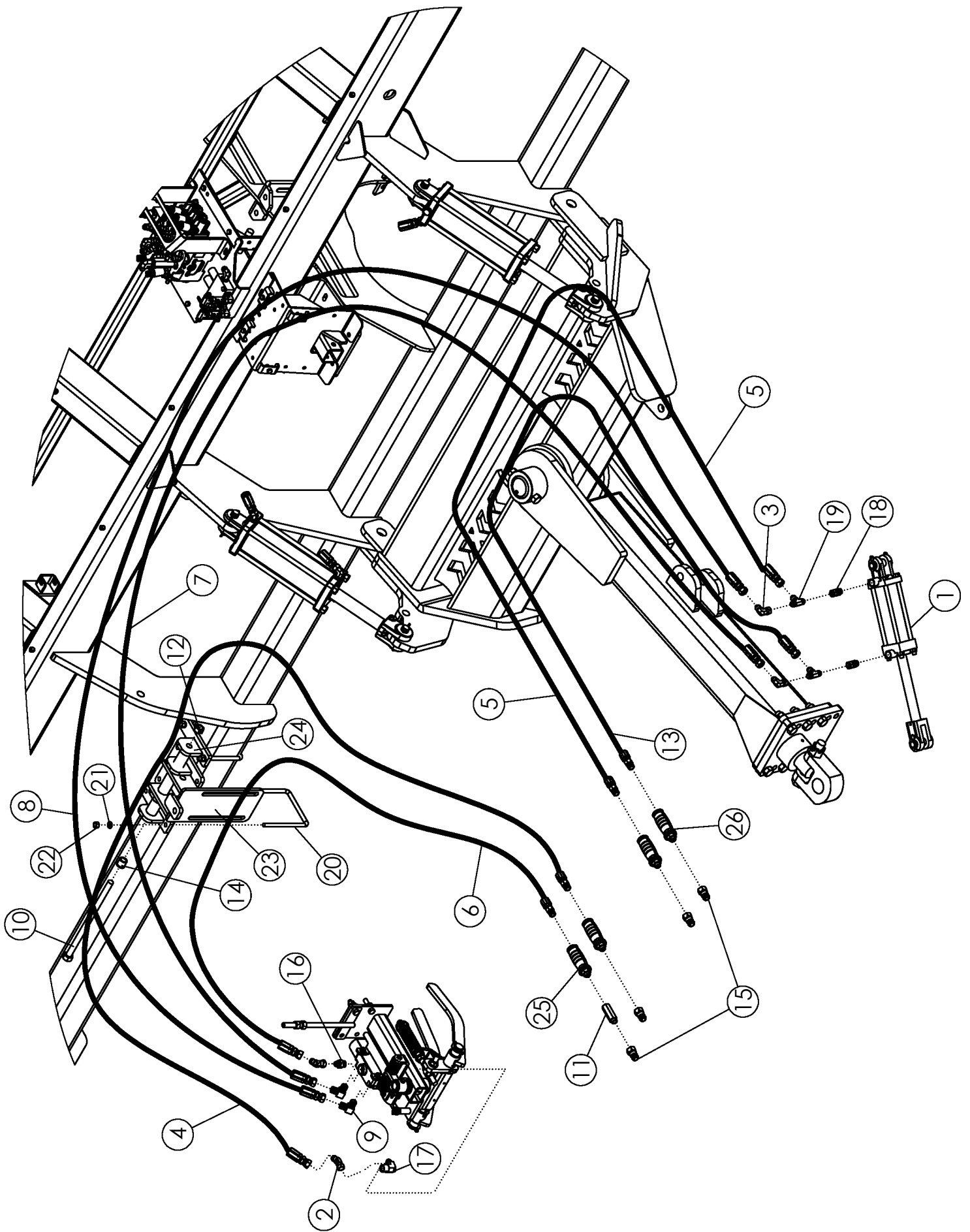

FRAME MOUNTED ROW FINDER HYDRAULICS

ITEM	PART NO.	DESCRIPTION	QTY
1	58891	CYLINDER-HYDRAULIC 4 X 8" 3000	1
	301315	SEAL KIT UNIVERSAL	
2	57663	FTG-ELBOW: 8MJ-8FJX-45	2
3	57668	FTG-ELBOW: 8MJ-8FJX 90	2
4	301642	HOSE: .50 X 322 8MB-8FJX	1
5	301645	HOSE: .50 X 215 8MB-8FJX	1
6	301641	HOSE: .50 X 314 8MB-8FJX	1
7	301644	HOSE: .50 X 295 8FJX-8FJX	1
8	301643	HOSE: .50 X 286 8FJX-8FJX	1
9	58560	FTG-ELBOW: 8MB-8MJ-90	2
10	63664	BOLT-HEX: .75 X14.00 NC GR5 ZP	1
11	300070	CHECK VALVE 8MB-8FB FLOW F-->M (FC-08R)	1
12	1017000	NUT-TOPLOCK: .75 NC GR5 ZP	1
13	301646	HOSE: .50 X 223 8MB-8FJX	1
14	52654	1050187 BUSHING	2
15	36290	PIONEER TIP 8010-15P (#8 ORB)	4
16	58195	FTG-ADAPTER: 10MB-8MJ	1
17	65901	FTG-ELBOW: 10MB-8MJ-90	1
18	56941	FTG-ADAPTER: 8MB-8FJX	2
19	57667	FTG-TEE: 8MJ-8MJ-8MJ	2
20	53984	U-BOLT: .500 X 7.00 X 6.00 X 7.00	2
21	1011581	WASHER-LOCK: .50 ZP	4
22	1011577	NUT-HEX: .50 NC GR2 ZP	4
23	63661	WLDMT-MOUNTING BRACKET	1
24	63662	WLDMT-MOUNTING SUPPORT	2
25	301902	HYD LABEL: .50 BLUE/GRAY SET	1
26	301917	HYD LABEL: .50 YELLOW/GRAY SET	1

****IMPORTANT**** ITEM 11 (PN: 300070-CHECK VALVE) MUST BE INSTALLED AS SHOWN PER THE DIAGRAM, TO PREVENT PREMATURE ROW FINDER VALVE FAILURE.

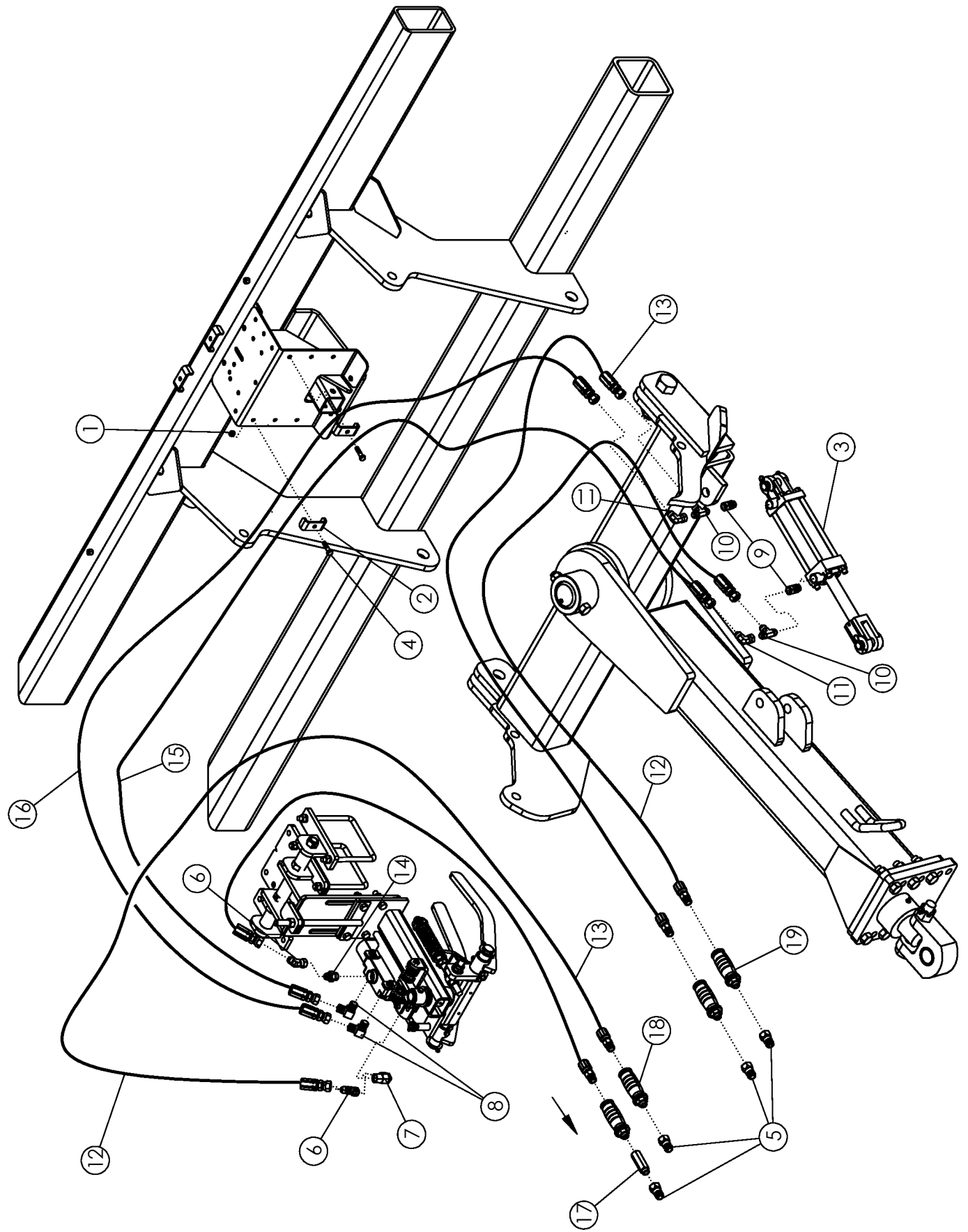

HITCH MOUNTED ROW FINDER HYDRAULICS

ITEM	PART NO.	DESCRIPTION	QTY
1	1016999	NUT-TOPLOCK: .38 NC GR5 ZP	6
2	50714	CLAMP .50 ZP	6
3	58891	CYLINDER-HYDRAULIC 4 X 8" 3000	1
	301315	SEAL KIT FOR 58991 UNIVERSAL	
4	1011603	BOLT-HEX: .38 X 1.75 NC GR5 ZP	6
5	36290	PIONEER TIP 8010-15P (#8 ORB)	6
6	57663	FTG-ELBOW: 8MJ-8FJX-45	1
7	65901	FTG-ELBOW: 10MB-8MJ-90	2
8	58560	FTG-ELBOW: 8MB-8MJ-90	4
9	56941	FTG-ADAPTER: 8MB-8FJX	2
10	57667	FTG-TEE: 8MJ-8MJ-8MJ	4
11	57668	FTG-ELBOW: 8MJ-8FJX 90	2
12	300039	HOSE: .50 X 184 8MB-8FJX	2
13	66200	HOSE: .50 X 188 8MB-8FJX	2
14	58195	FTG-ADAPTER: 10MB-8MJ	1
15	57672	HOSE: .50 X 098 8FJX-8FJX	1
16	57673	HOSE: .50 X 096 8FJX-8FJX	1
17	300070	CHECK VALVE 8MB-8FB FLOW F-->M (FC-08R)	1
18	301902	HYD LABEL: .50 BLUE/GRAY SET	1
19	301917	HYD LABEL: .50 YELLOW/GRAY SET	1

****IMPORTANT** ITEM 17 (PN: 300070-CHECK VALVE) MUST BE INSTALLED AS SHOWN PER DIAGRAM, TO PREVENT PREMATURE ROWFINDER VAVE FAILURE.**

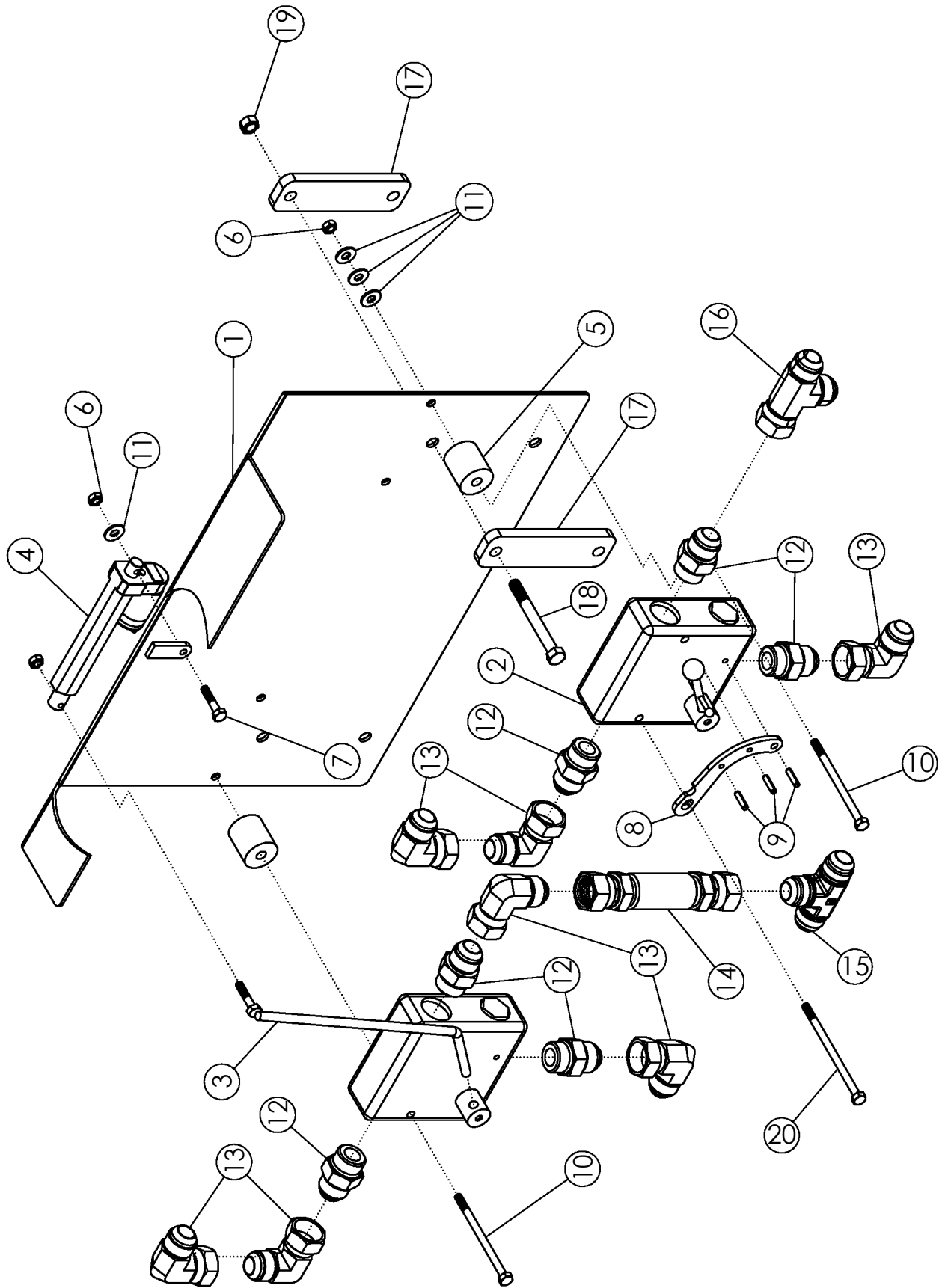

VALVE GROUP: DUAL MOTOR SCRUB

ITEM	PART NO.	DESCRIPTION	QTY
1	68092	WLDMT-BRACKET FLOW CONTROL	1
2	301266	VALVE-FLOW CONTROL- 12FB	2
	301375	SEAL KT-VALVE FLOW CONTROL #301266	
3	59524	WLDMT-ARM FLOW CONTROL Z.P.	1
4	59633	ACTUATOR-12VDC 4" STROKE	1
5	59463	SPACER	4
6	1030946	NUT-TOPLOCK: .25 NC GR5 ZP	6
7	1013940	BOLT-HEX: .25 X 1.25 NC GR5	1
8	59206	BRACKET-FLOW CONTROL ZP	1
9	54314	PIN-ROLL .19 X .75 ZP	3
10	1030776	BOLT-HEX: .25 X 4.00 NC GR5	4
11	1020416	WASHER-FLAT: .25 ZP	15
12	65918	FTG-ADAPTER: 12MB-12MJ	6
13	59041	FTG-ELBOW: 12MJ-12FJX 90	7
14	63471	ASSY-TUBE LINE .75 X 5.25 0-0	1
15	58986	FTG-TEE: 12MJ-12MJ-12MJ	1
16	59888	FTG-TEE: 12MJ-12FJX-12MJ	1
17	59881	BRACKET-BOLT PLATE	4
18	58176	BOLT-HEX: .38 X 3.50 NC GR5 ZP	4
19	1016999	NUT-TOPLOCK: .38 NC GR5 ZP	4
20	58875	BOLT-HEX: .25 X 4.50 NC GR5 ZP	1

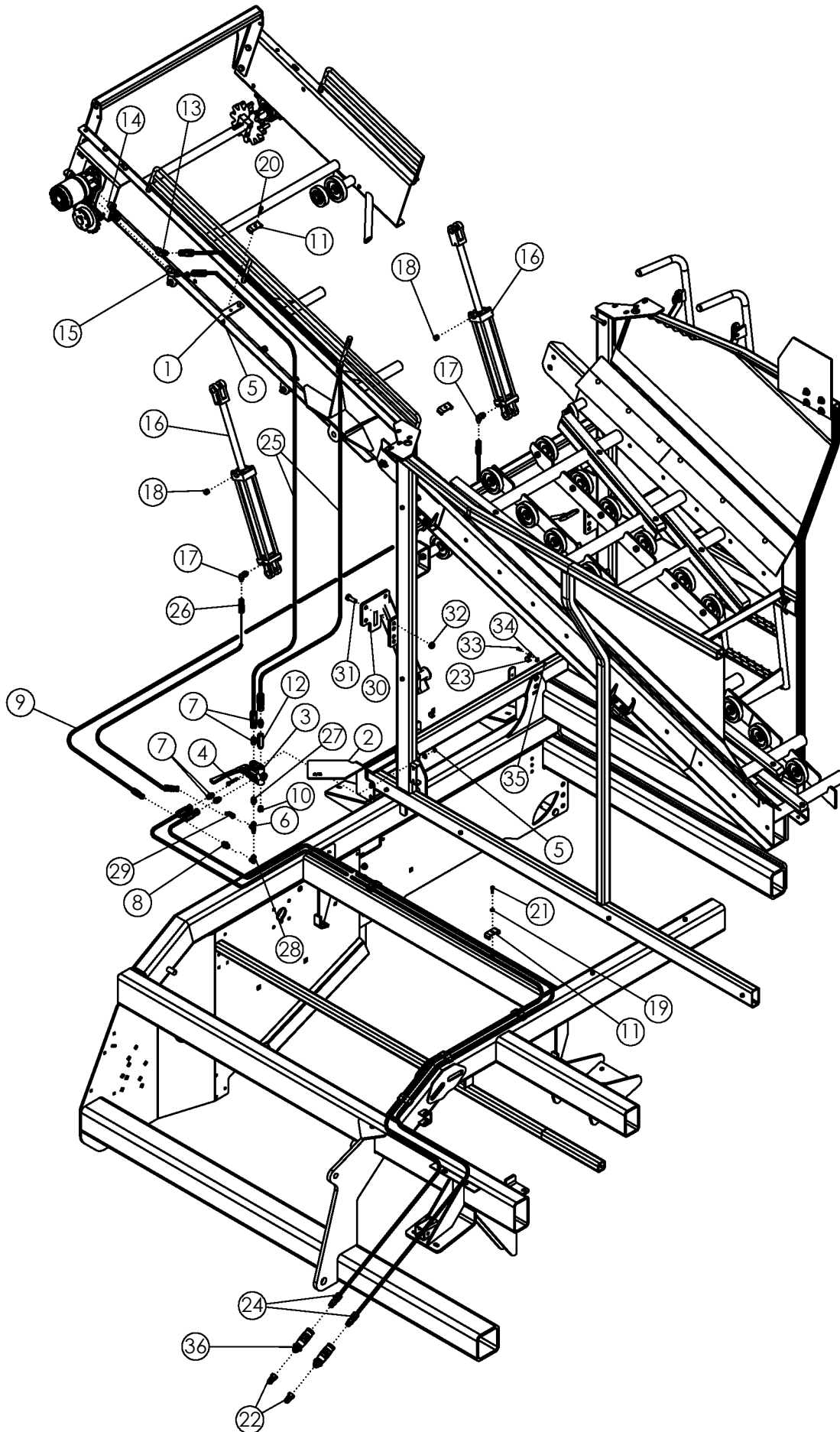

TANK HYDRAULICS

ITEM	PART NO.	DESCRIPTION	QTY
1	54825	BRACKET-HOSE ZP	2
2	62904	GUARD-SELECTOR VALVE	1
3	58470	VALVE-SELECTOR	1
4	59390	BOLT-HEX: .38 X 2.25 NC GR5 ZP	2
5	1016999	NUT-TOPLOCK: .38 NC GR5 ZP	5
6	56231	FTG-TEE: 6MJ-6FJX-6MJ	1
7	56226	FTG-ADAPTER: 8MB-8MJ	4
8	300072	FITTING-RESTRICTOR (6MJ-6FJ R 1/16)	1
9	58867	HOSE: .38 X 110 6FJX-6FJX	1
10	56190	FTG-PLUG: 8MB	1
11	50714	CLAMP 1/2" ZP	10
12	300070	VALVE-CHECK: 8MB-8FJ FLOW F-->M	1
13	58515	FTG-ELBOW: 8MB-8MJ-45	1
14	300069	FTG-ADAPTER: 8FB-10MB	1
15	56229	FTG-ELBOW: 10MB-8MJ-45	1
16	58889	CYLINDER-HYD 2.5 X 16	2
17	58557	FTG-ELBOW: 8MB-6MJ 90	2
18	58547	FTG-PLUG: 8MB BREATHER	2
19	1011586	WASHER-LOCK: .38 ZP	7
20	1011602	BOLT-HEX: .38 X 1.50 NC GR5 ZP	3
21	1011600	BOLT-HEX: .38 X 1.00 NC GR5 ZP	7
22	36290	PIONEER TIP 8010-15P (#8 ORB)	2
23	50779	HOSE-CLAMP	2
24	300076	HOSE: .50 X 262 8MB-8FJX	2
25	59889	HOSE: .50 X 161 X 8FJX-8FJX	2
26	44159	HOSE: .38 X 040 6FJX-6FJX	1
27	66624	FTG-ADAPTER: 6MJ-8MB	1
28	57897	FTG-ELBOW: 6MJ-6FJX-90	1
29	301538	FTG-ELBOW: 6MJ-6FJX-45	1
30	301298	WLDMT-CYLINDER LUG	2
31	1013918	BOLT-HEX: .63 X 1.75 NC GR5 ZP	8
32	1016595	NUT-TOPLOCK: .63 NC GR5 ZP	8
33	1011595	BOLT-HEX: .25 X .75 NC GR5 ZP	2
34	1020416	WASHER-FLAT: .25 ZP	2
35	1030946	NUT-TOPLOCK: .25 NC GR5 ZP	2
36	301914	HYD LABEL: .50 GREEN/GRAY SET	1

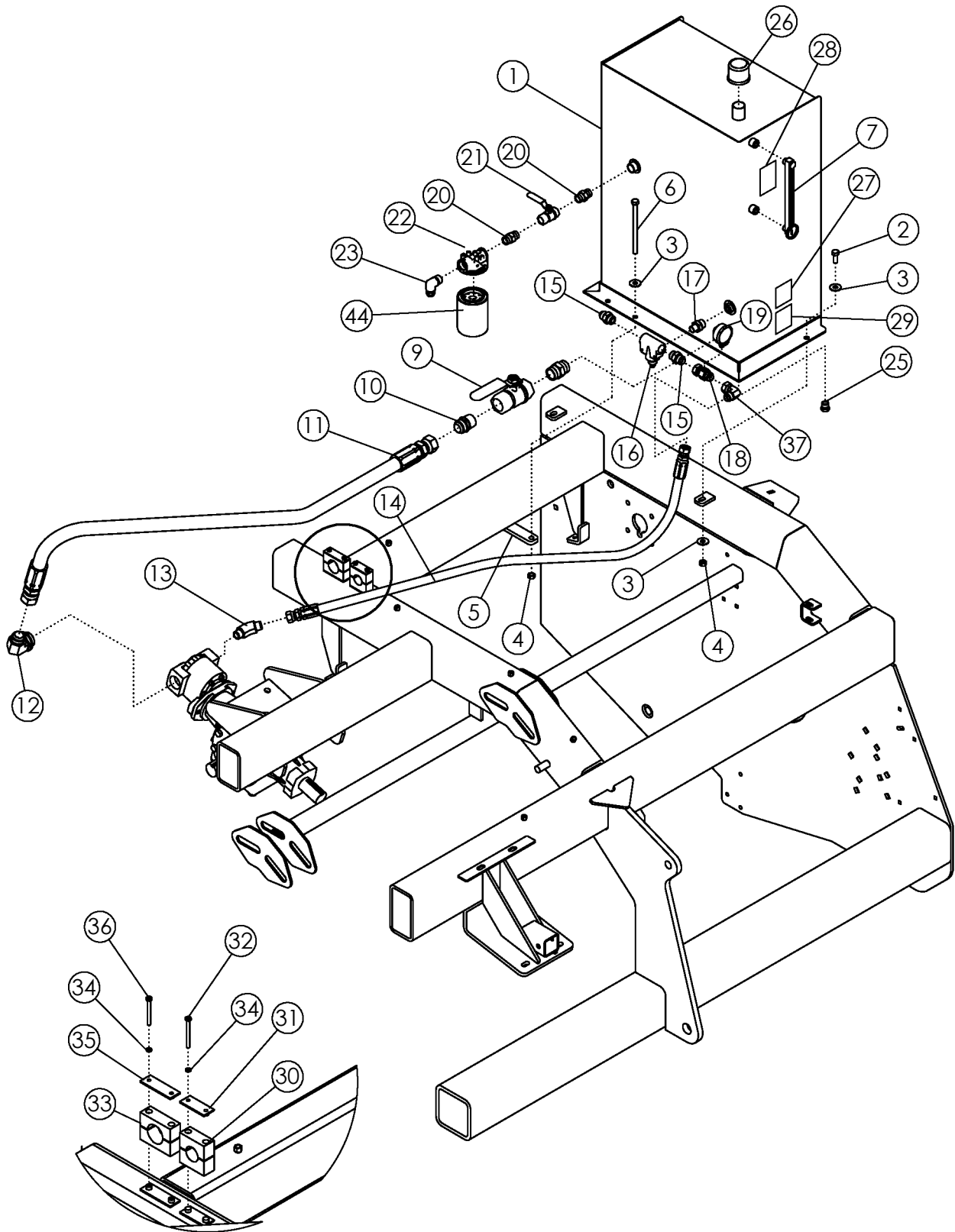

HYDRAULIC TANK			
ITEM	PART NO.	DESCRIPTION	QTY
1	58079	HYDRAULIC TANK-PAINTED	1
2	1011606	BOLT-HEX: .50 X 1.25 NC GR5 ZP	2
3	1014443	WASHER-FLAT: .50 ZP	6
4	1027461	NUT-TOPLOCK: .50 NC GR5 ZP	4
5	58204	BAR - BOLTING	1
6	1032514	BOLT-HEX: .50 X 7.50 NC GR5 ZP	2
7	58914	GAUGE-LEVEL & TEMP	1
8	58978	FTG-ADAPTER: 20MP-20MP	1
9	58979	VALVE-BALL: 20FP-20FP	1
10	62209	FTG-ADAPTER: 20MP-20MJ	1
11	62213	HOSE: 1.25 X 084 20FJX-20FJX	1
12	58980	FTG-ELBOW: 24MB-20MJ-90	1
13	62212	FTG-ELBOW: 16MB-12MJ-45	1
14	62517	HOSE: .75 X 079 12FJX-12FJX	1
15	65918	FTG-ADAPTER: 12MB-12MJ	2
16	302997	VALVE-RELIEF 2500PSI	1
17	303000	FTG-ADAPTER: 12MB-8MP	1
18	301173	FTG-ADAPTER: 12MJ-12FJX W/4FB	1
19	301175	GAUGE-PRESSURE: 1/4" MB 3000PSI	1
20	58196	FTG-ADAPTER: 12MP-12MP	2
21	59165	VALVE-BALL 3/4FP - 3/4FP	1
22	58690	FILTER HEAD	1
23	59044	FTG-ELBOW: 12MP-12MJ-90	1
24	303695	FILTER-HYDRAULIC 4" (10 MICRON)	1
25	55718	FTG-PLUG: 8MB	1
26	58197	CAP-FILLER	1
27	62964	DECAL-WARNING	1
28	303269	DECAL-HYDRAULIC OIL	1
29	64429	DECAL-WARNING BALL VALVE	1
30	64645	CLAMP-STAUFF 6445PPH (2 HALVES)	1
31	64646	PLATE-COVER DP5	1
32	1032287	BOLT-HEX: .25 X 2.75 NC GR5 ZP	2
33	64612	CLAMP-STAUFF 5278PPH (2 HALVES)	1
34	1013242	WASHER-LOCK: .25 ZP	4
35	64613	PLATE-COVER DP6	1
36	1032285	BOLT-HEX: .25 X 2.50 NC GR5 ZP	2
37	59041	FTG-ELBOW: 12MJ-12FJX-90	1

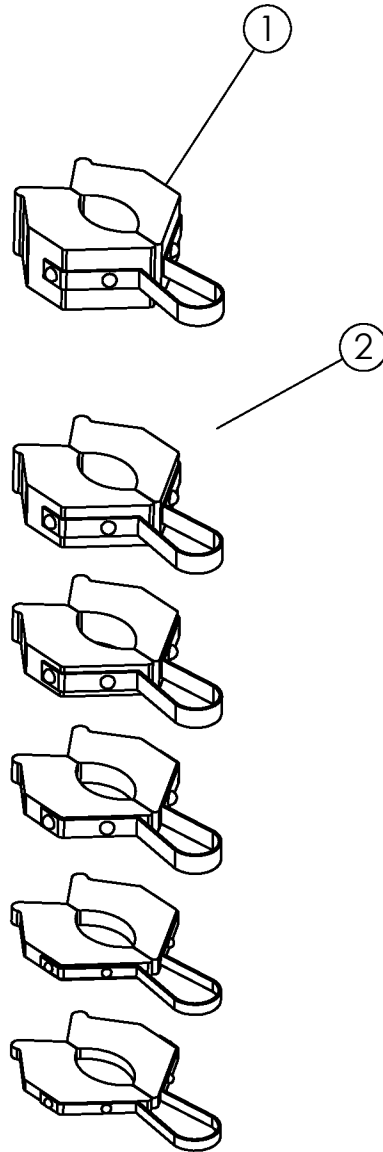
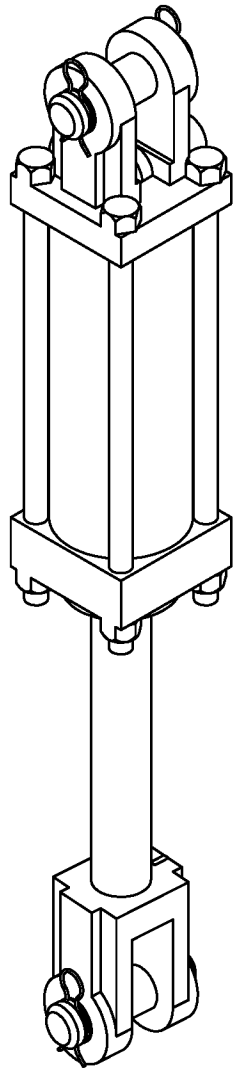

CYLINDER STOP KIT #51497 (OPTIONAL)

ITEM	PART NO.	DESCRIPTION	QTY
1	54004	STOP-CYLINDER 1.5" (SILVER)	1
2	52320	CYLINDER STOP A-KT (.25 THRU 1.00)	1

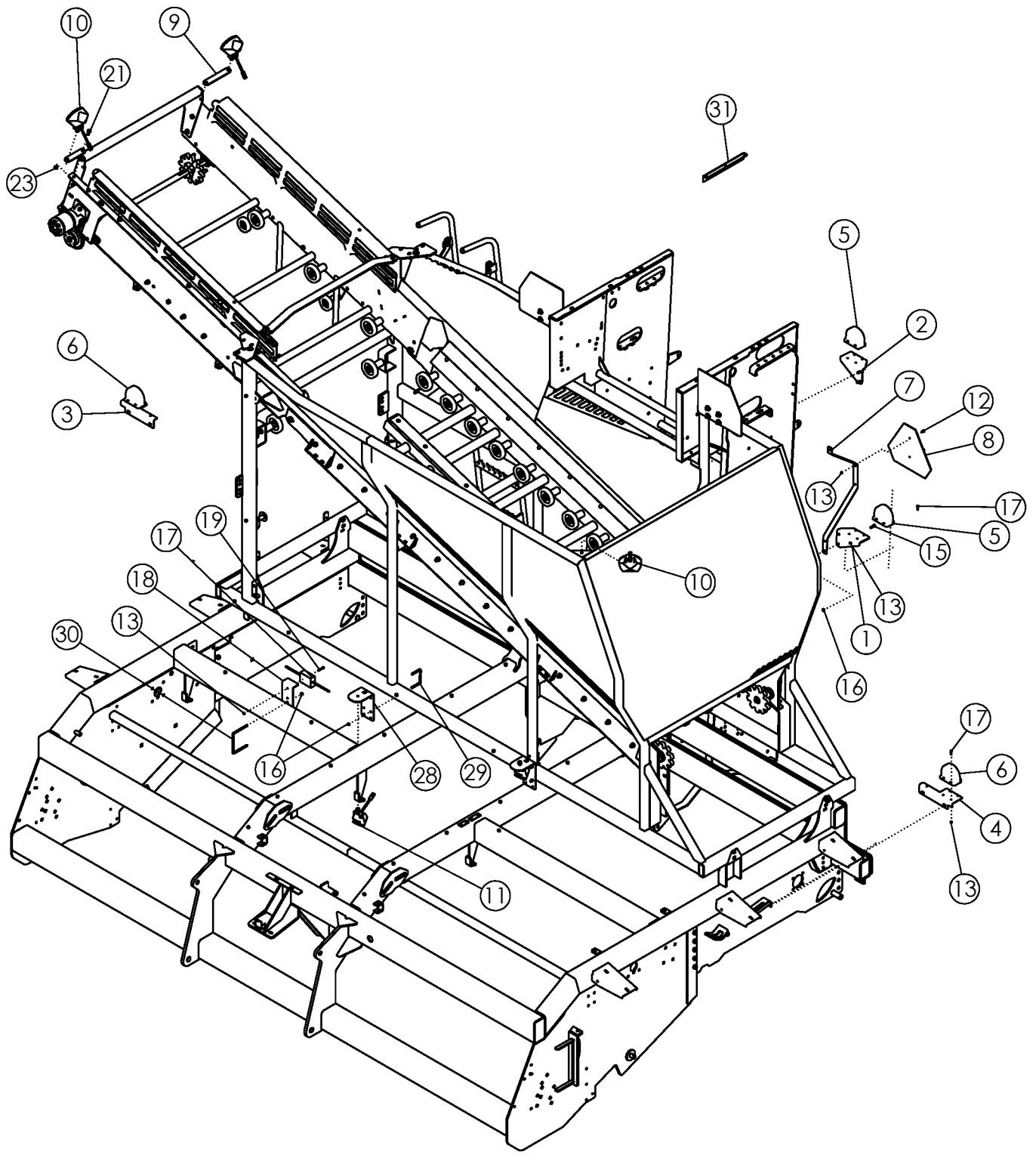

LIGHT KIT HD

ITEM	PART NO.	DESCRIPTION	QTY
1	64236	BRACKET-LIGHT RH RED	1
2	64235	BRACKET-LIGHT LH RED	1
3	64175	BRACKET RH	1
4	64176	BRACKET LH	1
5	305218	LIGHT-RED LAMP SAE	2
6	305217	LIGHT-YELLOW LAMP SAE	2
7	64290	MOUNT-SMV SIGN	1
8	65329	SIGN-SMV ASAE	1
9	300326	PLATE-LIGHT MOUNT BOOM	2
10	301293	LIGHT-GROTE 2000 OVAL FLOOD	2
11	301294	LIGHT-GROTE T26 NEAR FLOOD	3
12	1011595	BOLT-HEX: .25 X .75 NC GR5 ZP	2
13	1030946	NUT-TOPLOCK: .25 NC GR5 ZP	20
14	1011601	BOLT-HEX: .38 X 1.25 NC GR5 ZP	4
15	1016999	NUT-TOPLOCK .375 NC GR5 ZP	4
16	1013423	BOLT-HEX: .25 X 1.00 NC GR5 ZP	16
17	305216	HARNESS-FLASHER MODULE	1
18	301339	PLATE-LIGHT MODULE MOUNT	1
19	1016853	BOLT-HEX: .25 X .75 NC GR5 ZP	2
20	301335	HARNESS-HARVESTER MAIN	1
21	301494	HARNESS-HARVESTER 8R HAZARD	1
22	1011606	BOLT-HEX: .50 X 1.25 NC GR5 ZP	2
23	1027461	NUT-TOPLOCK: .50 NC GR5 ZP	2
24	1013122	TIE-CABLE, NYLON 14.00" (NOT SHOWN)	40
25	62833	CLAMP-ADHESIVE BACKED CABLE (NOT SHOWN)	8
26	1011600	BOLT-HEX: .38 X 1.00 NC GR5 ZP (NOT SHOWN)	1
27	301495	HARNESS-HARVESTER WORK LIGHT	1
28	300327	PLATE-LIGHT MOUNT	2
29	306098	U-BOLT: .375 X 3.00 X 4.00 X 3.00 ZP	4
30	64364	U-BOLT: .375 X 5.13 X 6.00 X 5.13 ZP	1
31	64047	ANGLE-GUARD	1
32	300332	PLATE-LIGHT MOUNT BOOM (FRONT)	1

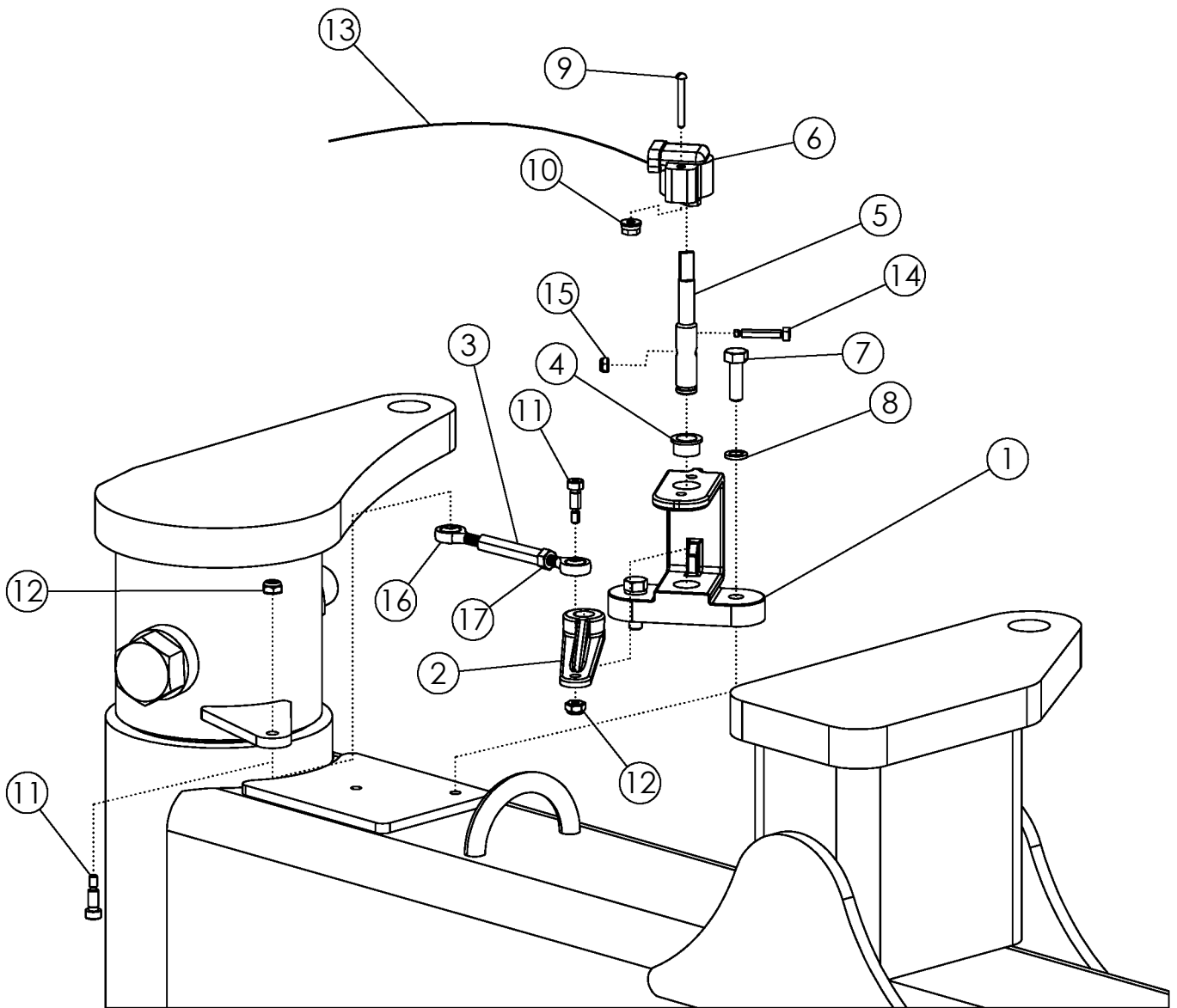
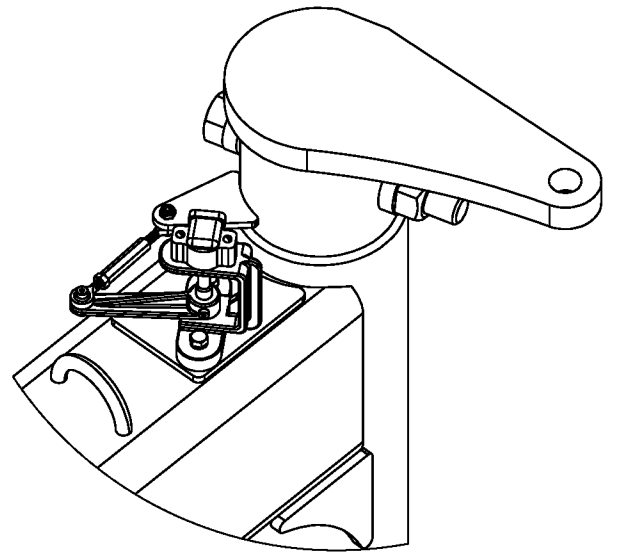

KIT-JD TOUCHSET 2200-2500 MODEL #302865

ITEM	PART NO.	DESCRIPTION	QTY
1	306820	SENSOR BRACKET-DLS	1
2	306823	LEVER-DLS	1
3	306830	TURNBUCKLE 1/4"-28	1
4	306822	GROMMET-DLS SHAFT	1
5	306827	SHAFT-DLS ZP	1
6	73492	SENSOR-ROTARY POSITION	1
7	1011598	BOLT-HEX: .31 X 1.00 NC GR5 ZP	2
8	1029115	WASHER-LOCK: .31 ZP	2
9	1011303	SCREW-MACH RND SLT: #10-24 X 1.25"	2
10	1026591	NUT-K-LOCK: #10-24 NC GR2 ZP	2
11	306832	BOLT-SHOULDER: 1/4" X 1/2" SHLD LNPTH X #10-24	2
12	67079	NUT-NYLOCK: #10-24 NC GR2 ZP	2
13	302778	HARNESS-JOHN DEERE TOUCH SET	1
14	306831	BOLT-SHOULDER: 3/16" X 1.0" SHLD LNPTH X #8-32	1
15	62617	NUT-NYLOCK: #8-32 GR2 ZP	1
16	306829	BALL JOINT ROD END, 1/4"-28 LH	1
17	1011579	NUT-HEX: .25 NF GR2 ZP	1
18	306825	SUPPORT-DLS SHAFT (NOT SHOWN)	1
19	306826	O-RING (NOT SHOWN)	1

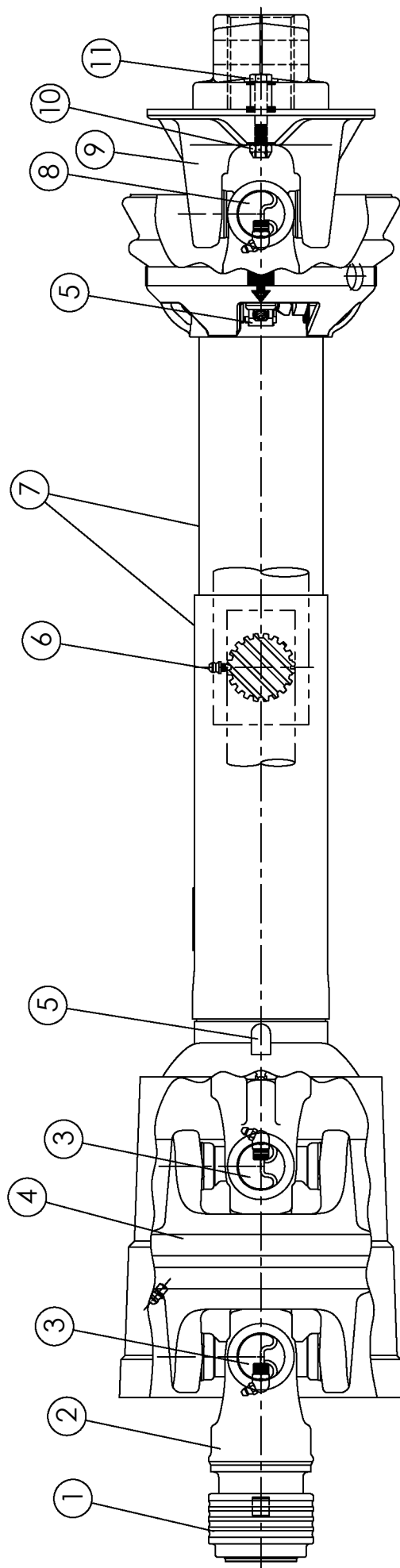

PTO CV DRIVELINE #301558**1.75" - 20 SPLINE**

ITEM	PART NO.	DESCRIPTION	QTY
1	62123	KT-SAFETY SLIDE LOCK REPAIR 1.750"	1
2	305902	YOKE ASSY-SAFETY SLIDE LOCK 1.750" CAT 6 CV	1
3	301841	KT-CROSS & BEARING CAT 6	2
4	305904	HOUSING-CV CENTER ASSY CAT 6	1
5	64398	KT-NYLON REPAIR UNIVERSAL	2
6	54161	ZERK-DRIVE LUBE FTG (PRESSED IN)	4
7	301559	GUARD SET-CV PTO HRV MAX 90" EXT.	1
8	54172	KT-CROSS & BEARING 35E SERIES	1
9	57286	ASSY-BALL SHEAR HRV	1
10	1030700	NUT-TOPLOCK: .31 NC GR5 ZP	1
11	1011285	BOLT-HEX: .31 X 2.00 NC GR5 ZP	1

PTO CV DRIVELINE #301575**1.375" - 21 SPLINE**

1	62122	KT-SAFETY SLIDE LOCK REPAIR 1.375"	1
2	301824	YOKE ASSY-SAFETY SLIDE LOCK 1.375" CAT 6 CV	1

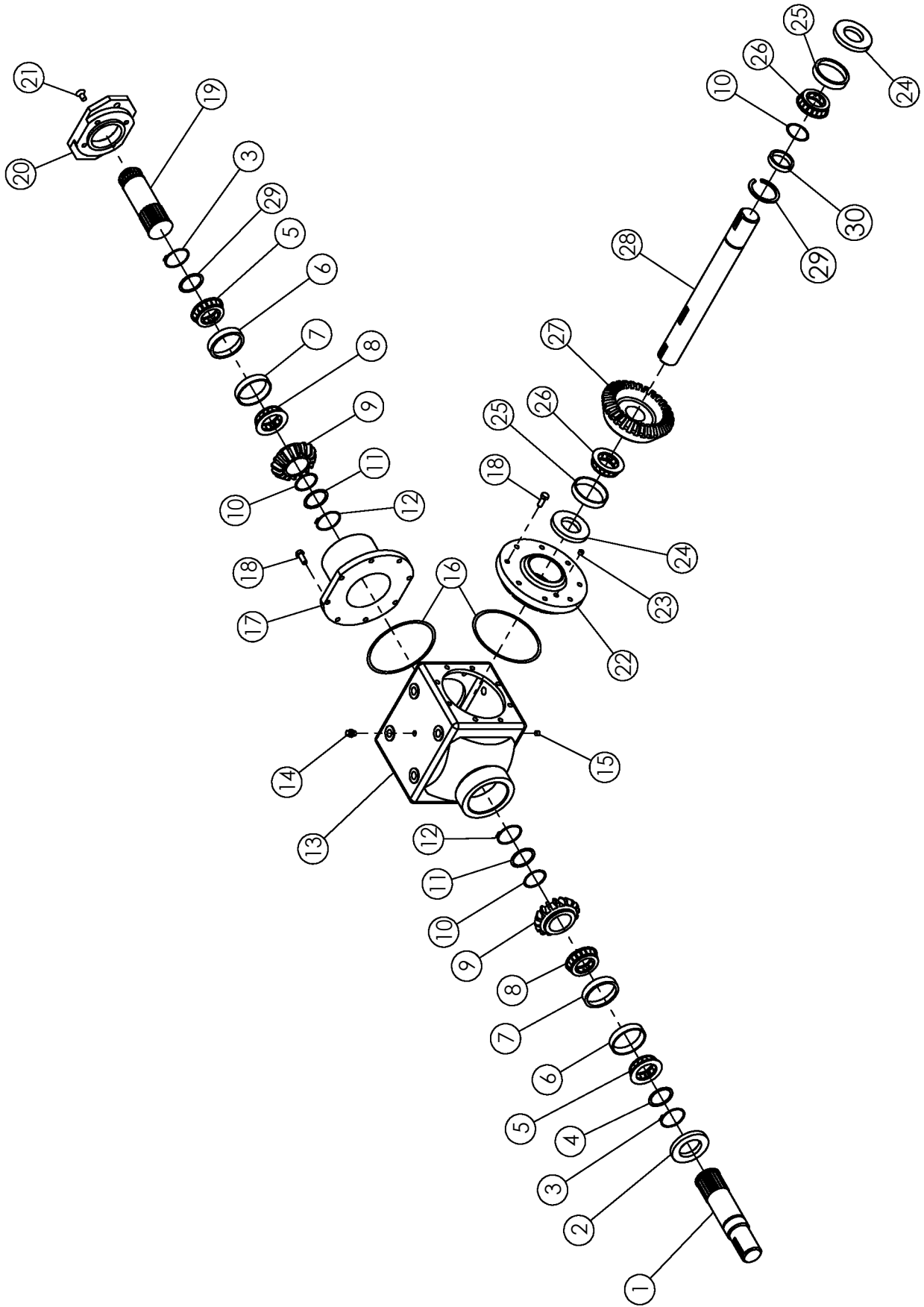

GEARBOX (1.81:1) #62015

ITEM	PART NO.	DESCRIPTION	QTY
1	62721	QUILL SHAFT	1
2	62722	SEAL: 2.00 - 3.26	1
3	62724	SNAP RING	2
4	62723	WASHER 2.00 X .13	2
5	62725	BEARING CONE	2
6	62726	BEARING CUP	2
7	62727	BEARING CUP	2
8	62728	BEARING CONE	2
9	62729	PINION-16 TOOTH	2
10	62730	SHIM: 1.75 X .007	3
11	62731	WASHER 1.75 X .179	2
	68599	WASHER 1.75 X .135	
12	62732	SNAP RING	2
13	62733	CASE-900 SERIES	1
14	64408	VENT PLUG: .50 NPT (SQ. HD.)	1
15	62735	PLUG: .50 NPT	1
16	62736	SHIM-COVER	2
17	62737	QUILL HOUSING	1
18	1011599	BOLT-HEX: .38 X .75 NC GR5 NP	16
19	68597	QUILL SHAFT	1
20	68596	FLANGE: 'SAE C' -2.00 BOLT	1
21	62741	SFHCS: .38 X .75 NC GR5	4
22	62742	COVER-OPEN .38 NPT	1
23	62743	PLUG: .38 NPT	1
24	62744	OIL SEAL: 1.75 X .31	2
25	62745	BEARING CUP	2
26	62746	BEARING CONE	2
27	64410	GEAR-29 TOOTH	1
28	64409	THRU SHAFT	1
29	68598	WASHER	1
SHIMS USE AS NEEDED			
	64457	SHIM COVER	
	64461	SHIM: 1.375 ID X .007	
	62730	SHIM: 1.75 ID X .007	
	69225	SHIM: 2.75 OD X .007	
	62736	SHIM COVER	
	301622	SHIM: 3.00 OD X 2.25 ID	
	301492	SHIM	

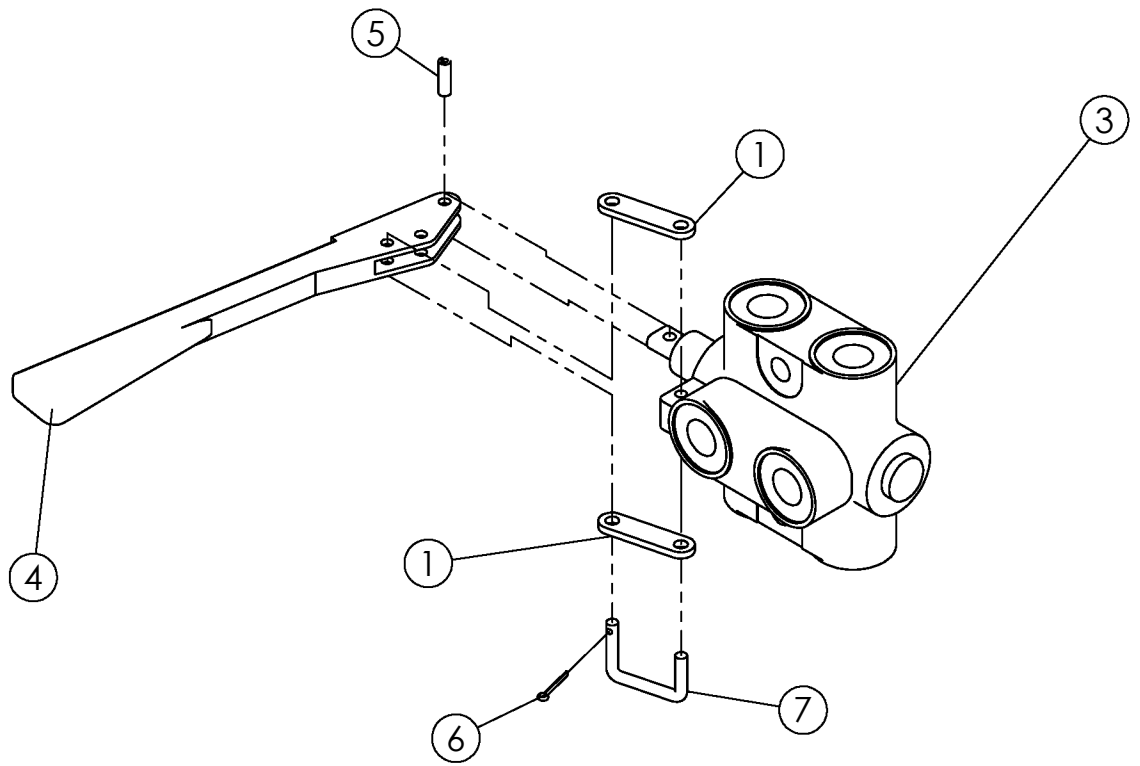

SELECTOR VALVE #58470

ITEM NO.	PART NO.	DESCRIPTION	QTY.
1	68060	PLATE ZP	2
3	53724	VALVE-SELECTOR	1
4	58470-2	HANDLE	1
5	58470-4	SPRING PIN	1
6	58470-5	PIN-COTTER HANDLE	1
7	58470-3	CLIP-HANDLE	1

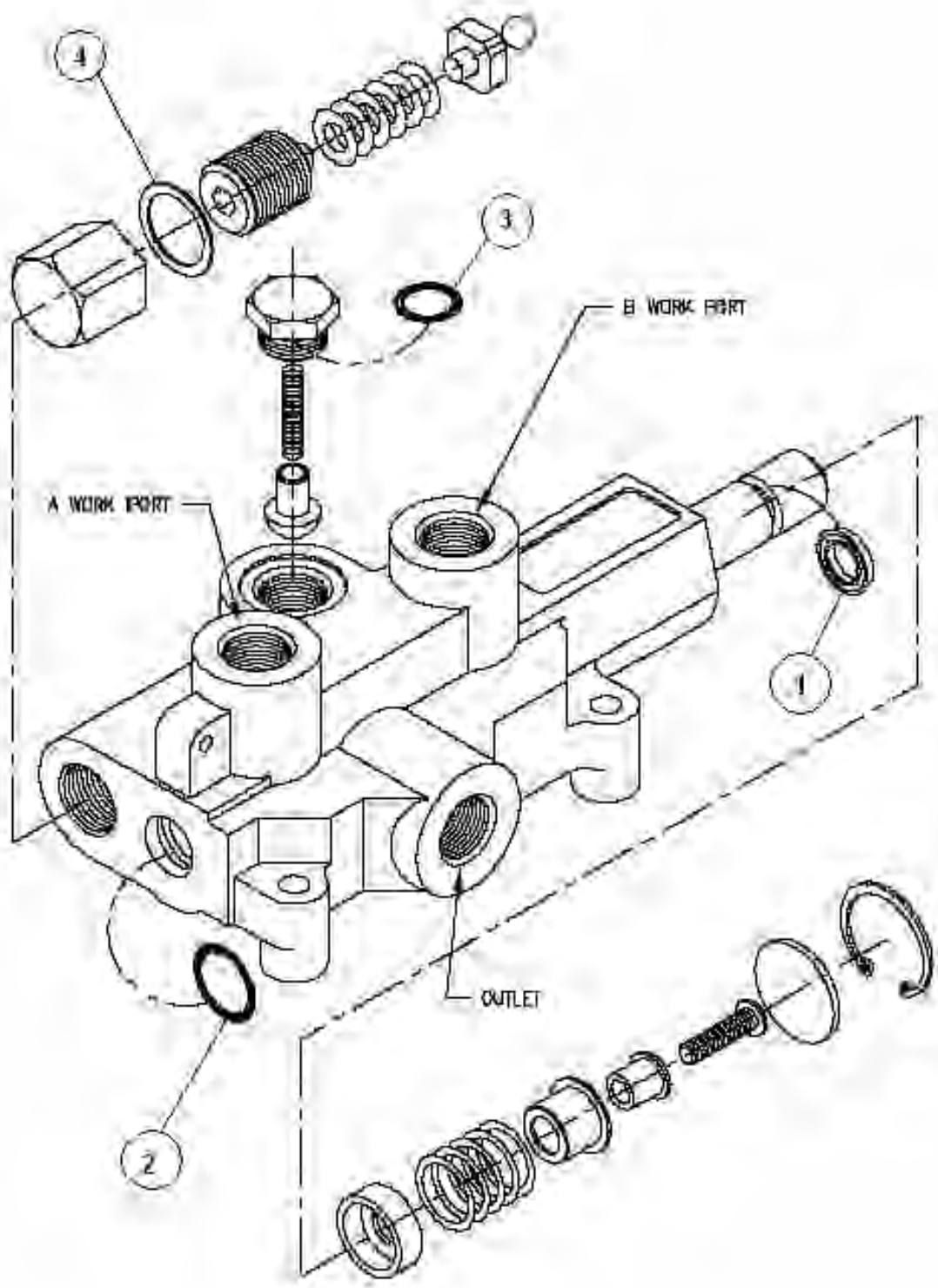

ROW FINDER VALVE #301150

ITEM	PART NO.	DESCRIPTION	QTY
	62757	SEAL KIT	
1		U-CUP	1
2		O-RING	1
3		O-RING	1
4		ALUMINUM WASHER	1

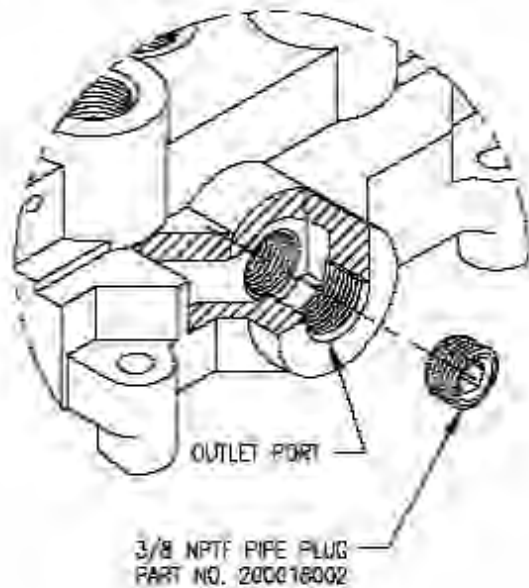

OPEN CENTER TO CLOSED CENTER CONVERSION

THIS FEATURE ALLOWS AN OTHERWISE OPEN CENTER VALVE TO BE CONVERTED TO CLOSED CENTER OPERATION. AS SHOWN ABOVE, A 3/8 NPTF PIPE PLUG IS INSTALLED IN THE BOTTOM OF THE OUTLET PORT TO BLOCK OPEN CENTER PASSAGE. A PIPE THREAD SEALANT SHOULD BE USED. THIS FEATURE IS STANDARD ON ALL VALVES WITH 3/4 NPTF INLET AND OUTLET PORTS. THE PIPE PLUG IS INCLUDED WITH THESE MODELS. DISCARD THE PIPE PLUG IF THE VALVE IS USED ON AN OPEN CENTER APPLICATION.

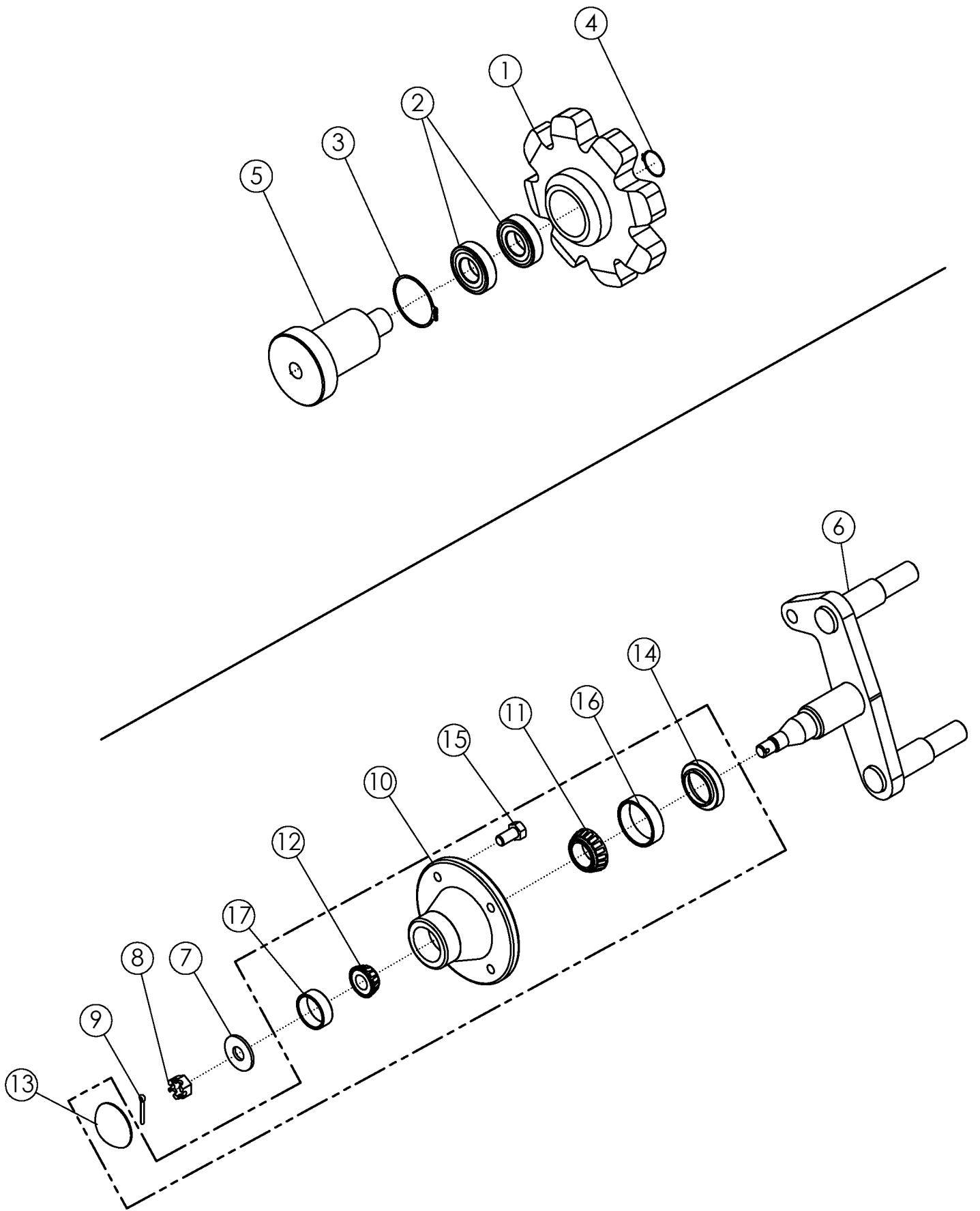

SPROCKET #54824			
ITEM	PART NO.	DESCRIPTION	QTY
1	56893	SPROCKET 56MM 8T	1
2	54108	BEARING 2"	2
3	54151	SNAP RING SR11	1
4	54154	SNAP RING SR3	1
5	56892	STUB SHAFT	1

BELT TIGHTENER #56422			
ITEM	PART NO.	DESCRIPTION	QTY
6	56421	WLDMT - SPINDLE	1
7	1013623	BUSHING-MACH: .63 NP	2
8	1013625	NUT-HEX: SLOT .63 NF GR5 ZP	1
9	1013626	PIN-COTTER: .16 X 1.25 ZP	1
10	1015157*	HUB-MACHINING	1
11	52245*	BEARING CONE-INNER	1
12	1013620*	CONE-BEARING	1
13	1013622*	HUB CAP	1
14	1029527*	SEAL	1
15	54646*	BOLT-LUG .50 X 1.00	4
16	1012360*	CUP-BEARING: LM 67010	1
17	1013268*	CUP-BEARING: LM 11910	1
18	56951	ASSY-HUB	1

*Items are included in item 18

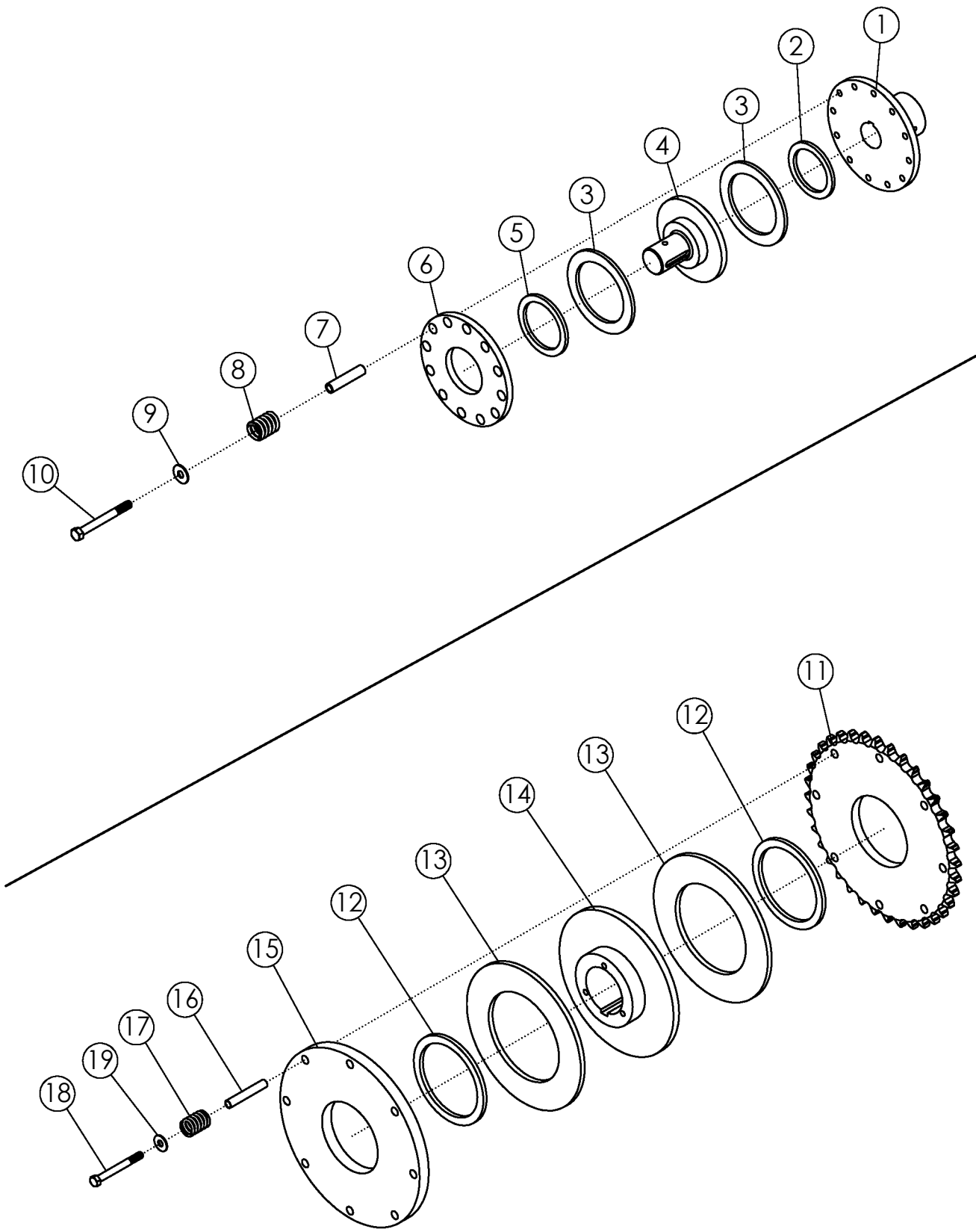

SLIP CLUTCH (IN-LINE) #57926

ITEM	PART NO.	DESCRIPTION	QTY
1	58168	HUB-DRIVE	1
2	58169	BUSHING-BRONZE	1
3	58170	DISC-FIBER	2
4	58171	HUB-SLIP CLUTCH	1
5	58172	BUSHING-BRONZE	1
6	58173	PLATE-SLIP CLUTCH	1
7	301701	TUBE-SLIP CLUTCH (2.38)	6
8	58174	SPRING-SLIP CLUTCH	6
9	1011828	WASHER-FLAT: .38 ZP	6
10	58176	BOLT-HEX: .38 X 3.50 NC GR5 ZP	6

SLIP CLUTCH/SPOCKET #57993

ITEM	PART NO.	DESCRIPTION	QTY
11	58177	SPROCKET	1
12	58207	BUSHING-BRONZE	2
13	58215	DISC-FIBER	2
14	58209	HUB-CLUTCH	1
15	58211	PLATE-SLIP CLUTCH	1
16	58213	TUBE-SLIP CLUTCH (2.870")	8
17	58174	SPRING-SLIP CLUTCH	8
18	58176	BOLT-HEX: .38 X 3.50 NC GR5 ZP	8
19	1011828	WASHER-FLAT: .38 ZP	8

SLIP CLUTCH/SPOCKET #58335

ITEM	PART NO.	DESCRIPTION	QTY
11	58566	SPROCKET	1
12	58208	BUSHING-BRONZE	2
13	58216	DISC-FIBER	2
14	58210	HUB-CLUTCH	1
15	58212	PLATE-SLIP CLUTCH	1
16	301701	TUBE-SLIP CLUTCH (2.38)	6
17	58174	SPRING-SLIP CLUTCH	6
18	1013239	BOLT-HEX: .38 X 3.00 NC GR5 ZP	6
19	1011828	WASHER-FLAT: .38 ZP	6

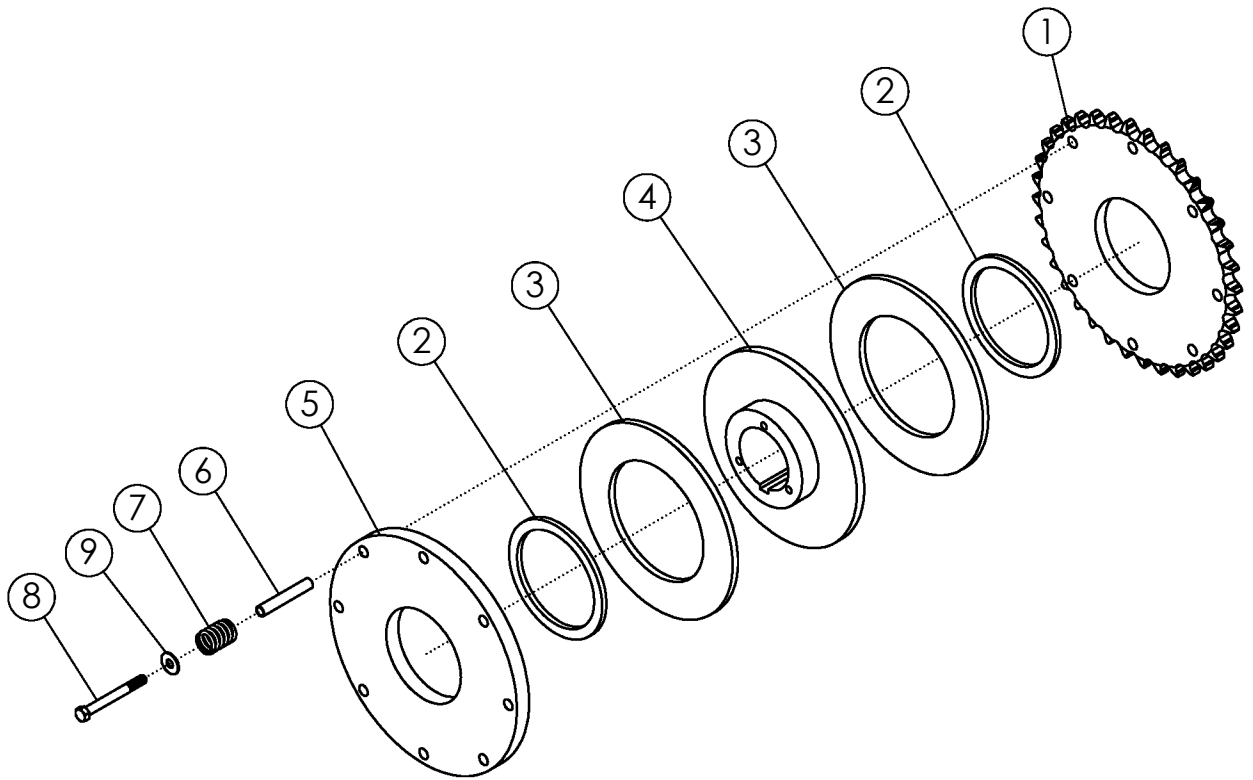

SLIP CLUTCH/SPOCKET #69630

ITEM	PART NO.	DESCRIPTION	QTY
1	69631	SPROCKET	1
2	58207	BUSHING-BRONZE	2
3	58215	DISC-FIBER	2
4	58209	HUB-CLUTCH	1
5	58211	PLATE-SLIP CLUTCH	1
6	58213	TUBE-SLIP CLUTCH (2.870")	8
7	58174	SPRING-SLIP CLUTCH	8
8	58176	BOLT-HEX: .38 X 3.50 NC GR5 ZP	8
9	1011828	WASHER-FLAT: .38 ZP	8

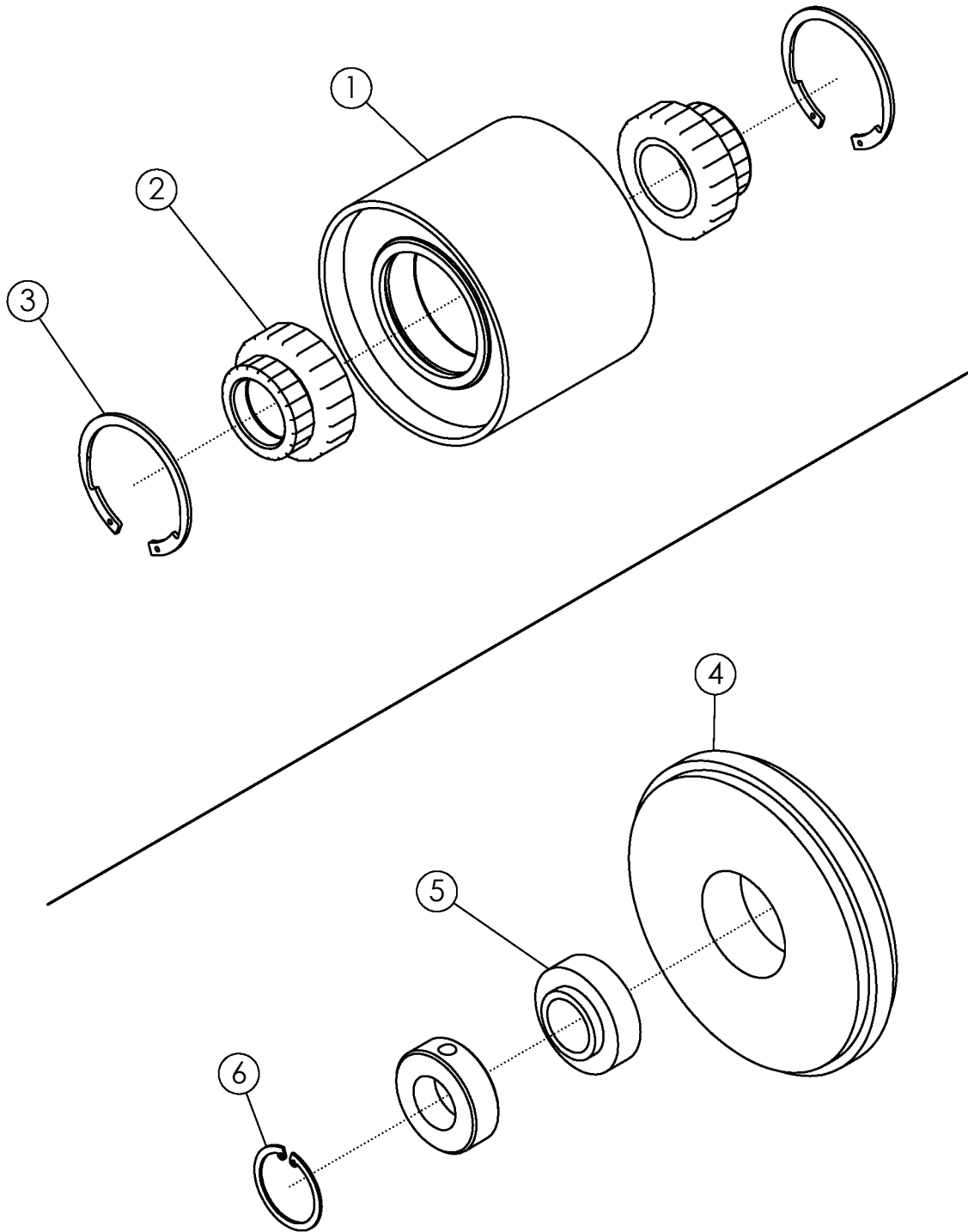

IDLER PULLEY #56409

ITEM	PART NO.	DESCRIPTION	QTY
1	56408	WLDMT-PULLEY 8R	1
2	56399	BALL BEARING 1.75	2
3	56400	RETAINING RING	2

SPROCKET IDLER #56851

ITEM	PART NO.	DESCRIPTION	QTY
4	56851*	ROLLER-IDLER	1
5	58806	BEARING-IDLER	1
6	58805	SNAP-RING	1

*COMES WITH ITEMS 5 & 6

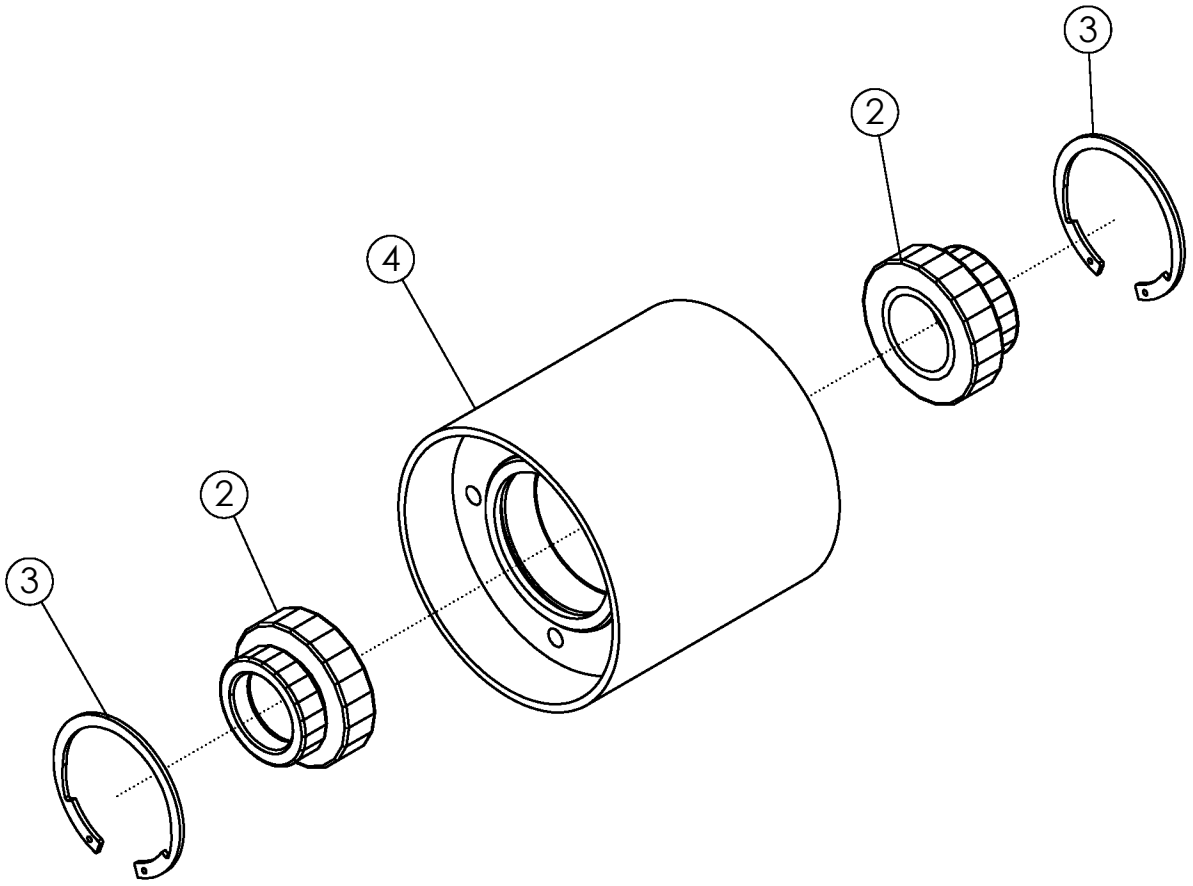

REVERSE PULLEY #301822

ITEM	PART NO.	DESCRIPTION	QTY
1	301823	WLDMT-REVERSE PULLEY	1
2	56399	BALL-INSERT 1-3/4"	2
3	56400	RETAINING RING	2

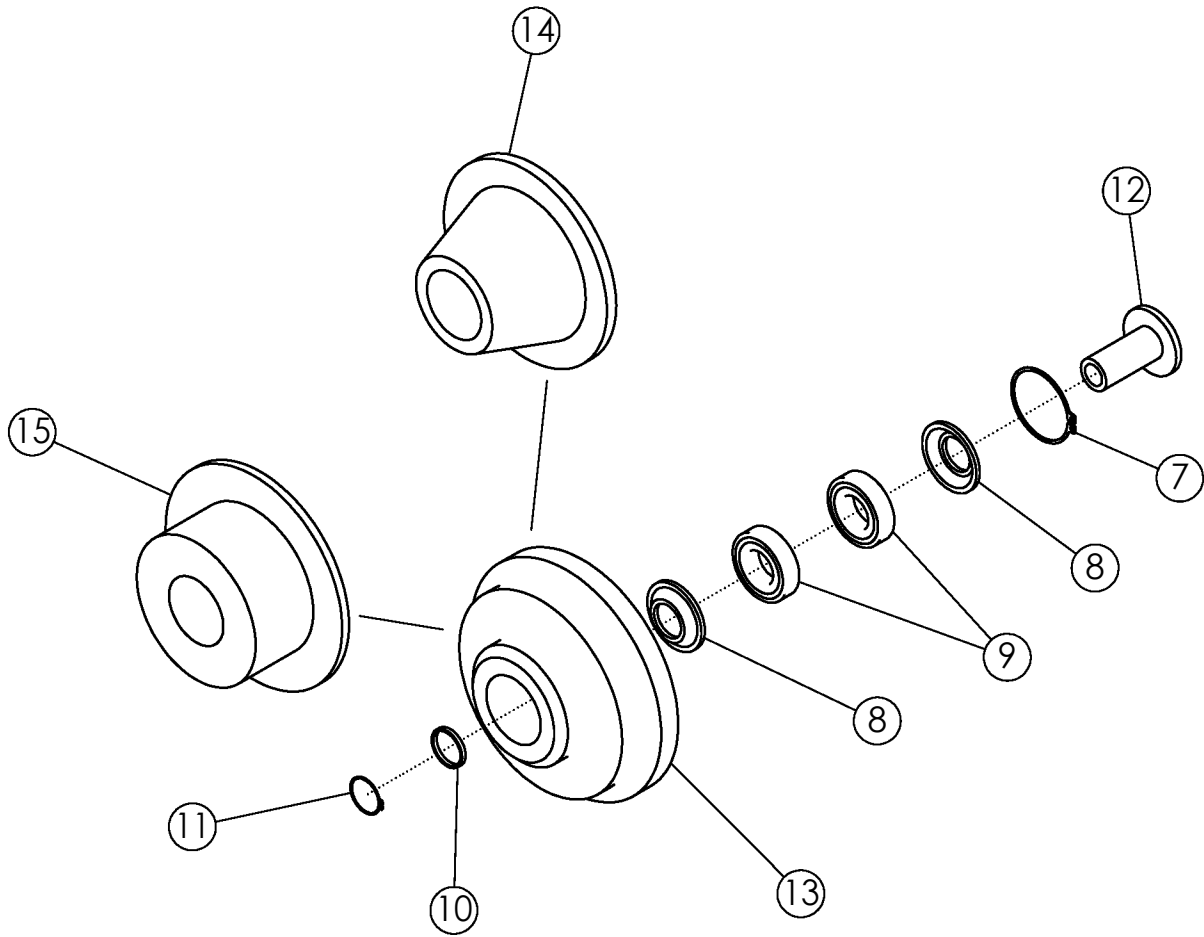
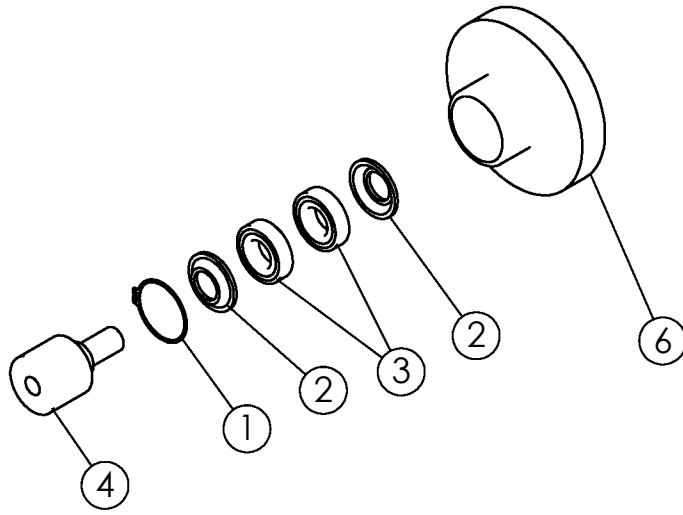

ROLLERS

ITEM	PART NO.	DESCRIPTION	QTY
1	54151	SNAP RING SR11	1
2	54152	WASHER	2
3	54108	BEARING 2"	2
4	56885	STUB SHAFT LONG	1
5	62702	STUB SHAFT SHORT	1
6	54042**	ROLLER-STEP 6"	1
7	54151	SNAP RING SR11	1
8	54152	WASHER	2
9	54108	BEARING 2"	2
10	54153	SPACER-NRS	1
11	54154	SNAP RING SR3	1
12	56889	STUB SHAFT	1
13	53951*	ROLLER-STEP FLANGE 7"	1
12	54155	STUB SHAFT	1
14	53950*	ROLLER-CONE 6"	1
12	54155	STUB SHAFT	1
15	59057*	ROLLER-RUBBER FLANGE 6.5"	1

* COMES WITH ITEMS 7-12

**COMES WITH ITEMS 1-5

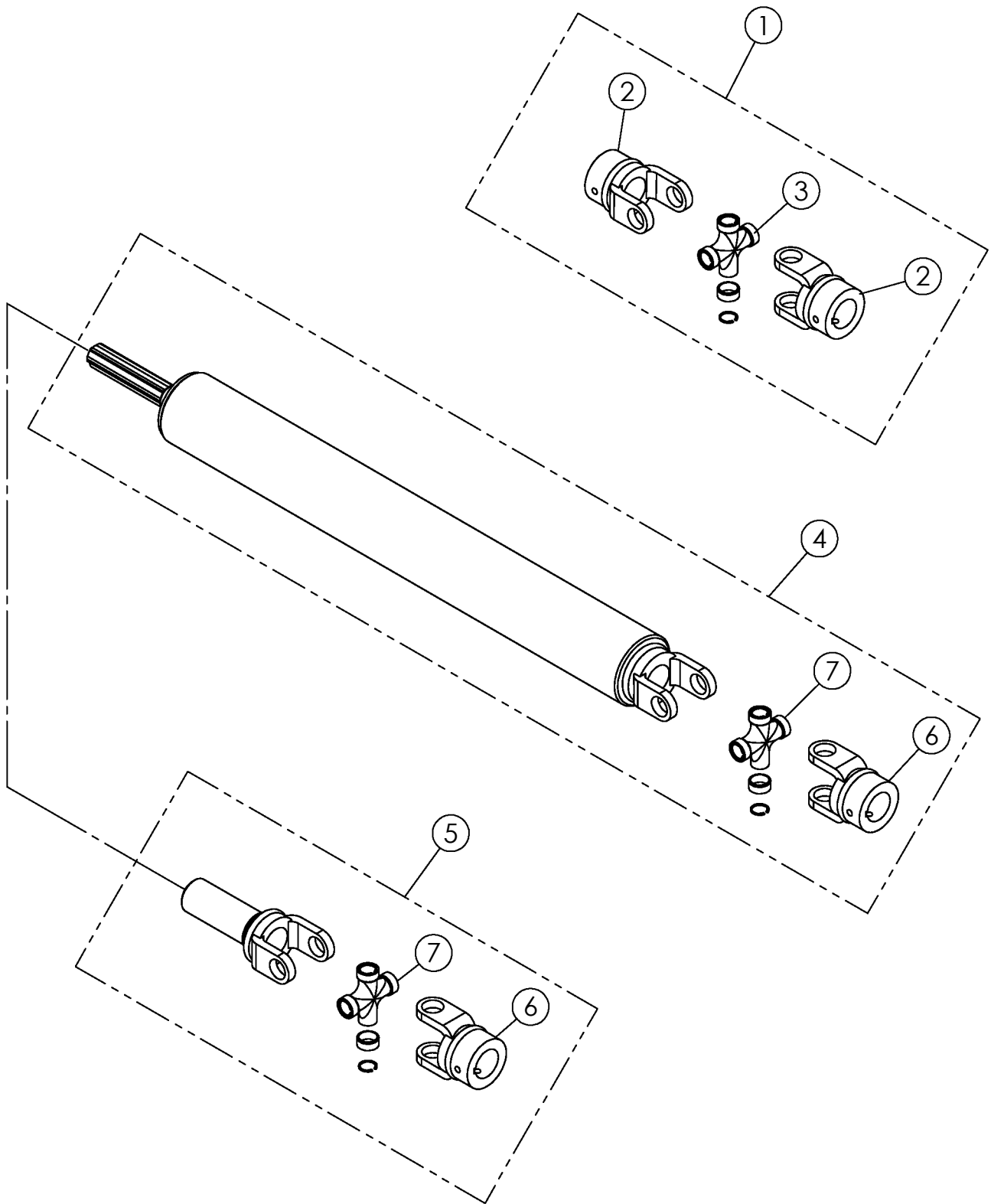

DRIVELINE COMPONENTS

ITEM	PART NO.	DESCRIPTION	QTY
1	53642	U-JOINT	1
2	55035	YOKE 1.75"	2
3	54172	35E CROSS & BEARING KIT	1
4	57923	DRIVE SHAFT 49.25"	1
	57924	DRIVE SHAFT 72.50"	
5	57925	DRIVE COUPLER	1
6	62037	YOKE 1.38"	1
7	58876	KT-CROSS & BEARING 14E SERIES	1

SCRUB DRIVELINE ASSEMBLY

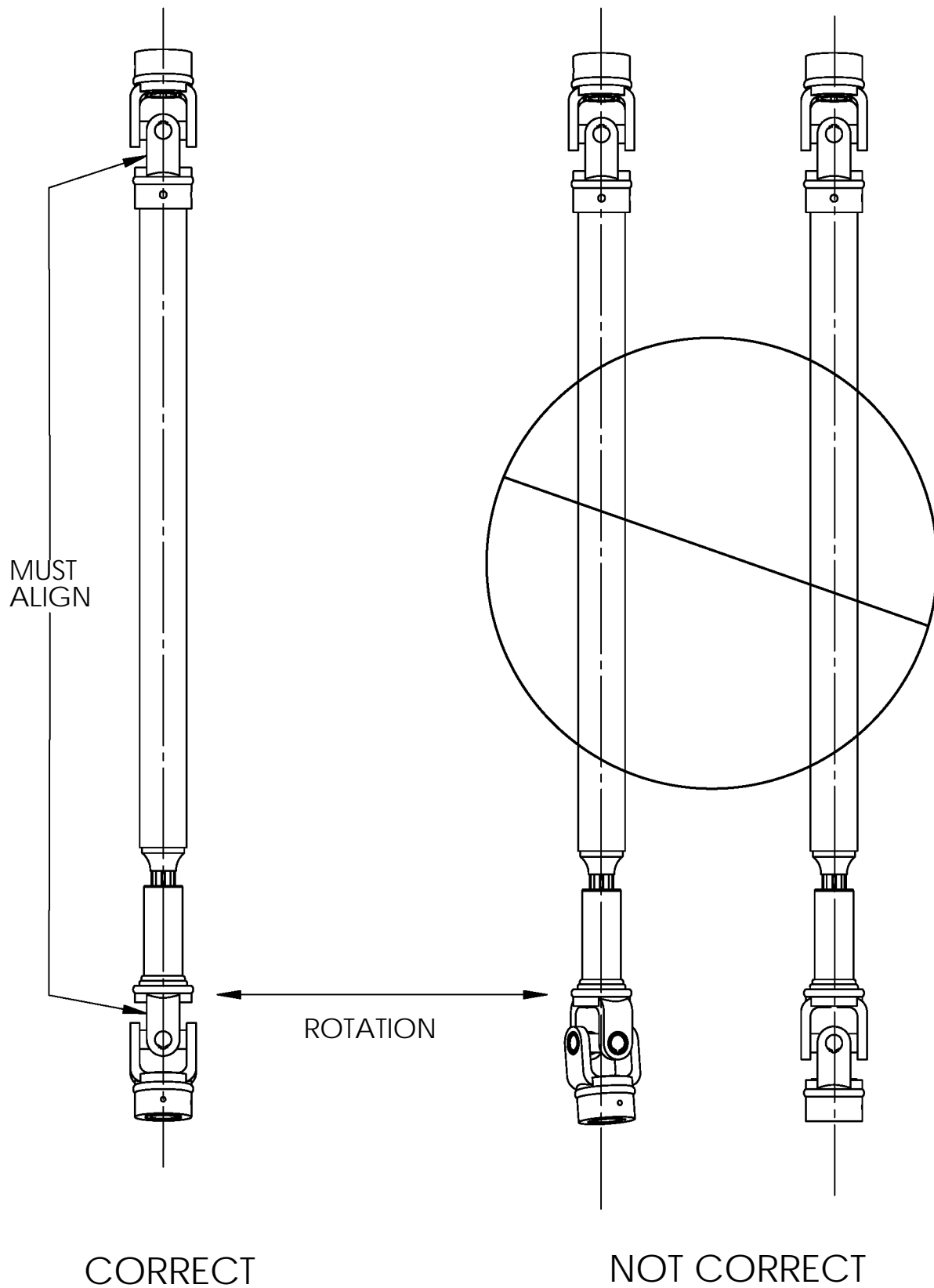

BELTED CHAIN LAP JOINT CONNECTION STANDARD

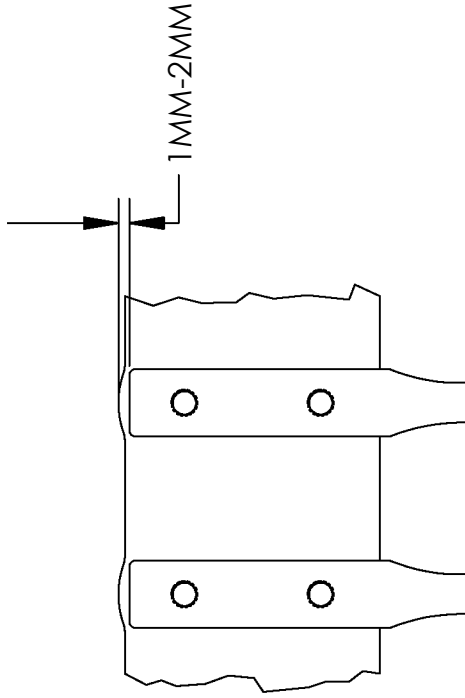
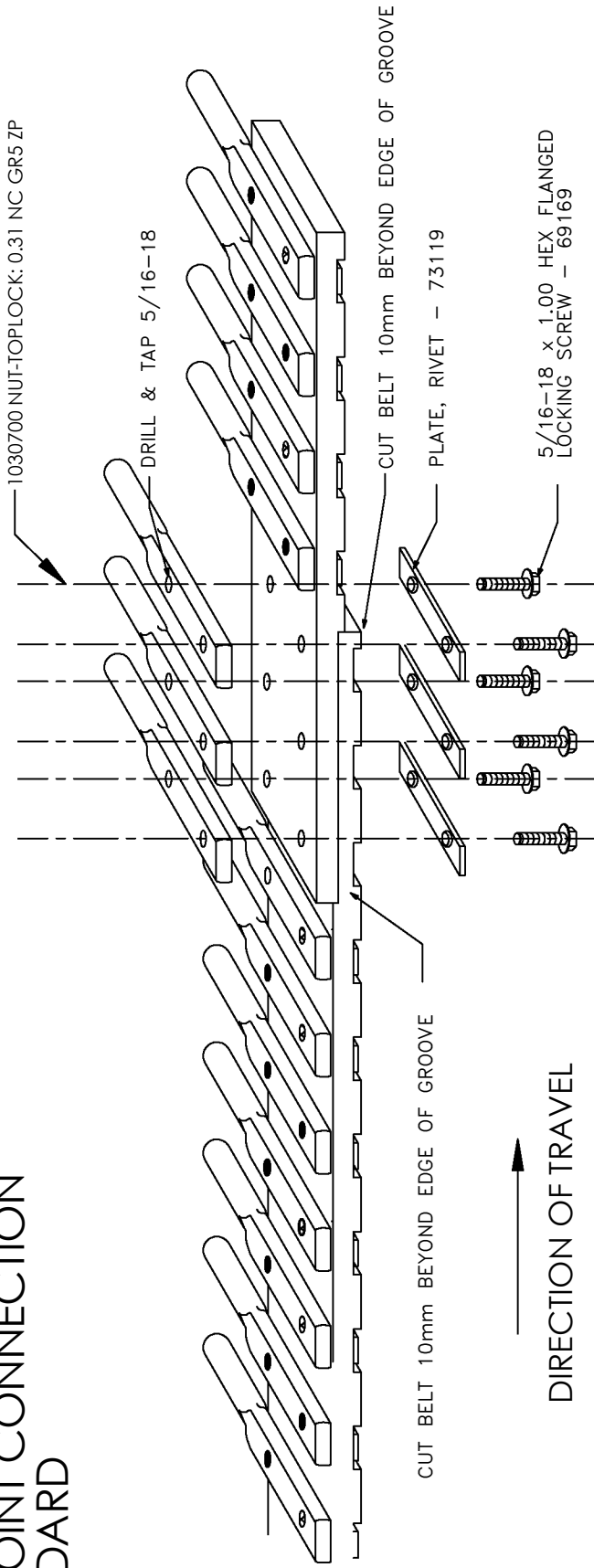

WARNING : ENSURE THAT SCREWS ARE SUFFICIENTLY TIGHT TO PRODUCE A BULGE AT THE EDGE OF THE BELT OF BETWEEN 1 AND 2mm (SEE DIAGRAM). FAILURE TO DO SO MAY CAUSE PREMATURE FAILURE AND VOID YOUR WARRANTY

RELACEMTN RODS

Elevator (Standard) Machine 6R/8R	Rod Diameter 0.5	ST 73122	FLT 69366
Elevator (Double) Machine 6R/8R	Rod Diameter 0.5	ST 301528	FLT 301526
Apron Machine 6R22/8R22 6R22/8R22 6R30	Rod Diameter 0.5 0.625 0.625	ST 73122 69660 64994	UP 73123 69661 69952
Scrub Machine 6R/8R	Rod Diameter 0.5	ST 73122	UP 73123

BELTED CHAIN LAP JOINT CONNECTION HIGH PROFILE

DIRECTION OF TRAVEL

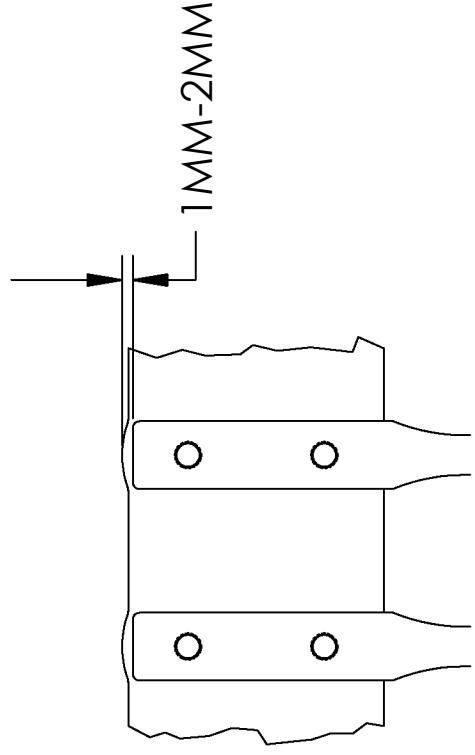
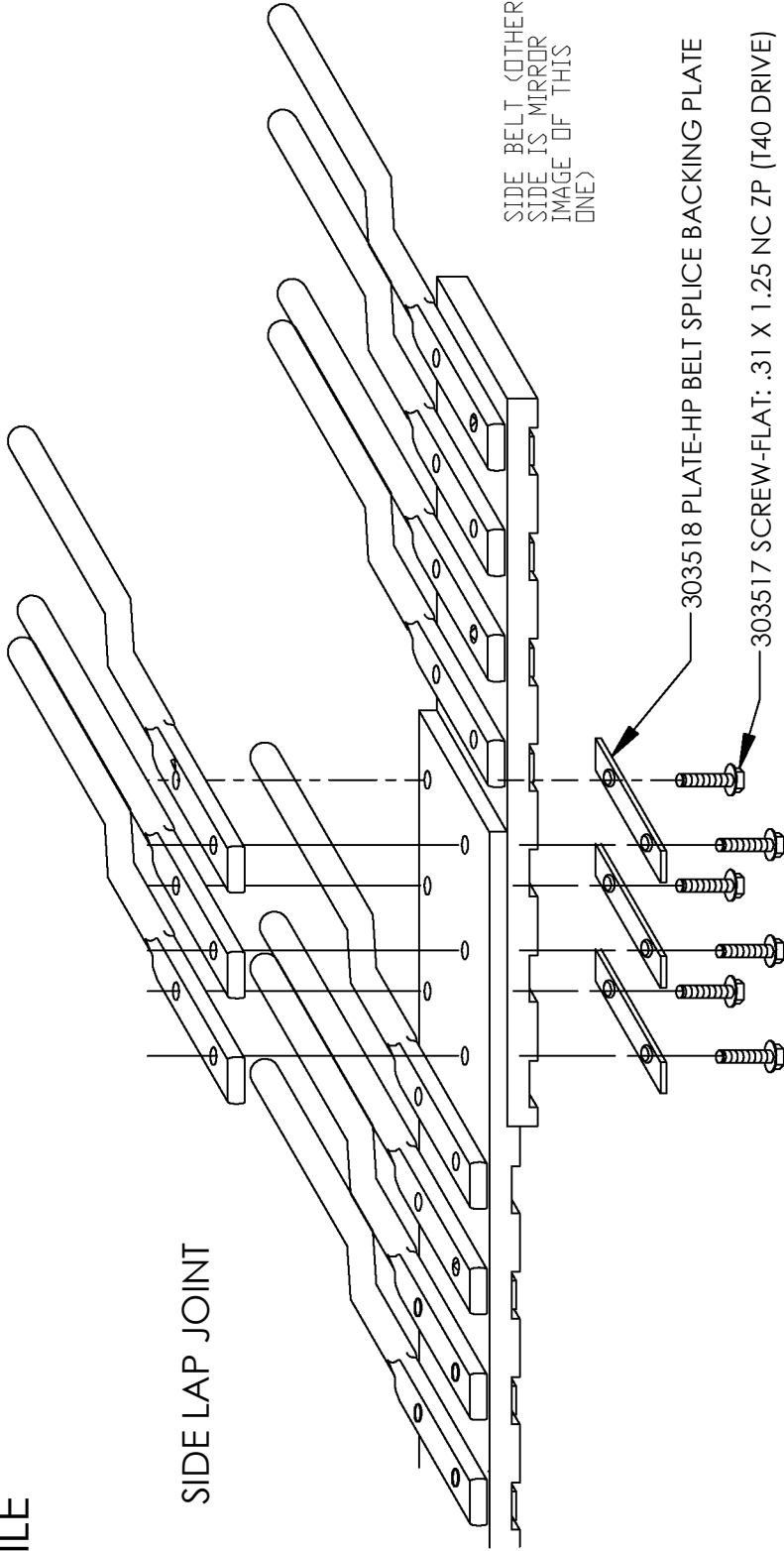

SCRUB	MACNINE	ROD DIAMETER	ST	UP
	6R/8R	0.5	73122	73123

WARNING : ENSURE THAT SCREWS ARE SUFFICIENTLY TIGHT TO PRODUCE A BULGE AT THE EDGE OF THE BELT OF BETWEEN 1 AND 2mm (SEE DIAGRAM). FAILURE TO DO SO MAY CAUSE PREMATURE FAILURE AND VOID YOUR WARRANTY

REPAIR KIT - BELTED CHAIN #69541

KIT CONSISTS OF:

- 1.25 FT - BELT, NO-PROFILE
- 8 EA - PLATE, RIVET
- 16 EA - SCREW
- 16 EA - NUT

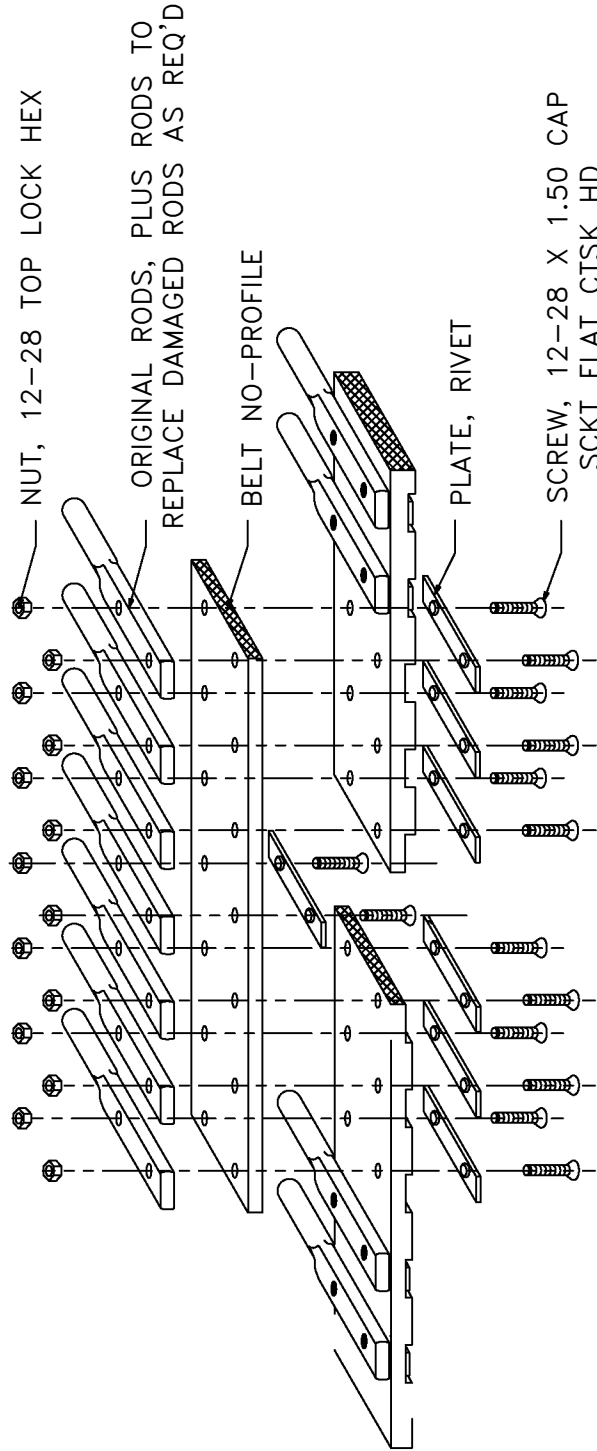

REPAIR PROCEDURE

1. REMOVE RIVETS 3 PITCHES (MIN) EACH SIDE OF DAMAGED BELT.
2. TRIM OUT DAMAGED BELT.
3. CUT NO-PROFILE BELT TO GIVE MINIMUM OF 3 PITCHES OVERLAP BOTH SIDES OF DAMAGE.
4. LAY NO-PROFILE BELT ON BELT TO BE REPAIRED AND DRILL HOLES TO MATCH PITCH.
5. ASSEMBLE AS SHOWN.
6. TIGHTEN SCREWS TO FORM APPROXIMATELY 2mm BELT SWELL AT BOLTED JOINT.
7. CUT OFF SCREWS NEXT TO NUTS.
8. PEEN SCREWS TO SECURE NUTS.

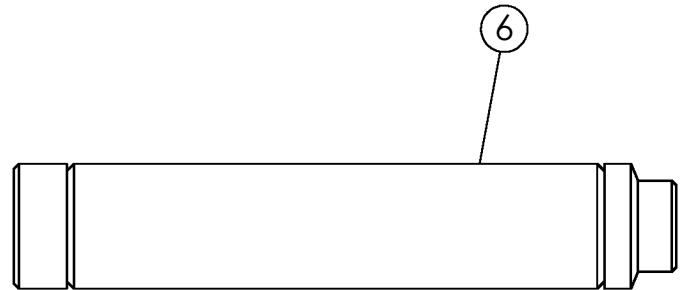
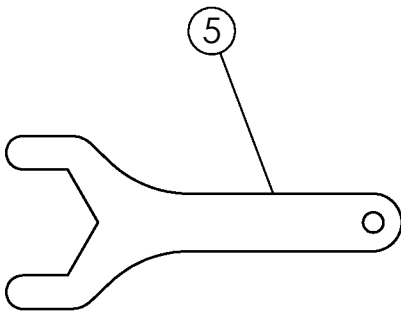
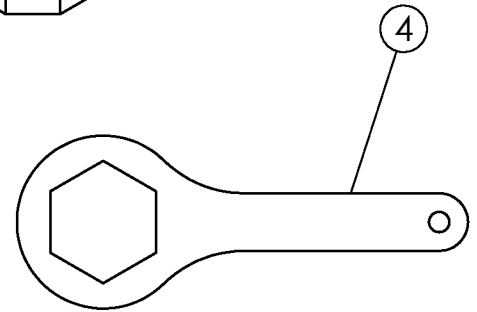
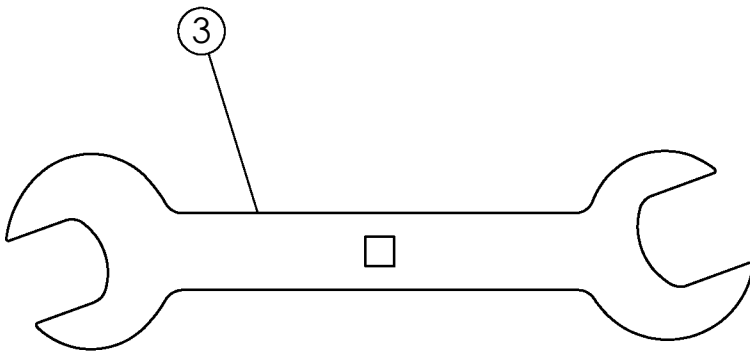
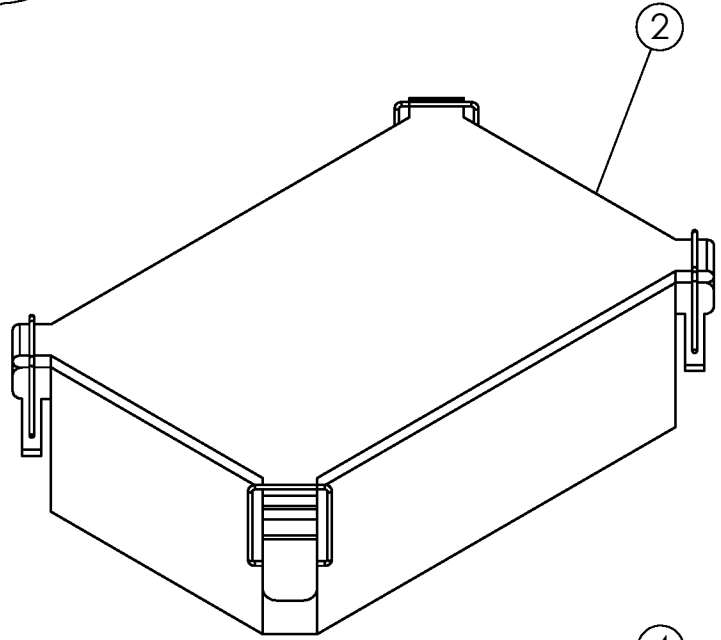
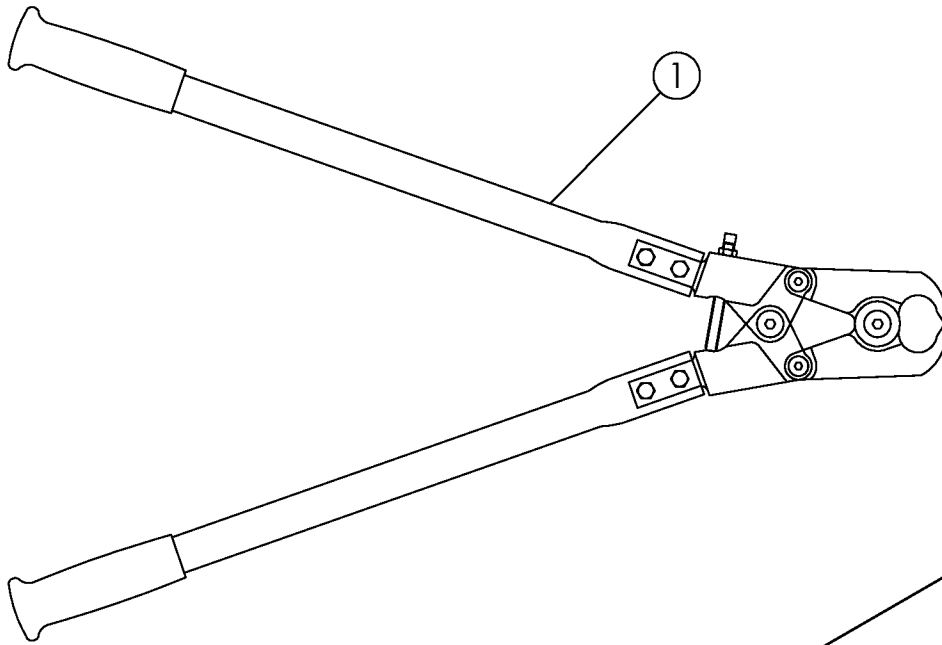

TOOLS

ITEM	PART NO.	DESCRIPTION	QTY
1	62802	TOOL-EASY CUTTER	1
2	303530	KT-ADC/AHC DIAGONSTIC TOOLS	1
	303521	HARNESS-2 PIN LIGHTED EXTENSION 4"	1
	303522	HARNESS-VALVE COIL VOLTAGE DIAGNOSTICS	1
	303523	HARNESS-WAND/BASKET VOLTAGE DIAGNOSTICS	1
	303524	HARNESS-ADC REAR CYL VOLTAGE DIAGNOSTICS	1
	303525	HARNESS-AHC REAR CYL VOLTAGE DIAGNOSTICS	1
	303526	HARNESS-VAVLE COIL TO POWER PACK	1
	303527	BATTERY-5V/12V OUTPUT POWER PACK	1
	303528	MANUAL-ADC/AHC DIAGONSTIC REFERENCE GUIDE	1
	303529	CASE-MILWAUKEE SMALL PACK OUT	1
	303696	HARNESS-VALVE COIL TO POWER PACK 12V	1
	303697	TESTER-POTENTIOMETER VOLTAGE TESTER (HEADSIGHT)	1
3	64320	WRENCH-TRANTORQUE	1
4	72417	WRENCH-BOX END	1
5	72418	WRENCH-OPEN END	1
6	59107	WLDMT-SOCKET 2.25 (1.75 BORE TT)	1
	59108	WLDMT-SOCKET 2.50 (2.00 BORE TT)	
	64820	WLDMT-SOCKET 2.75 (2.25 BORE TT)	

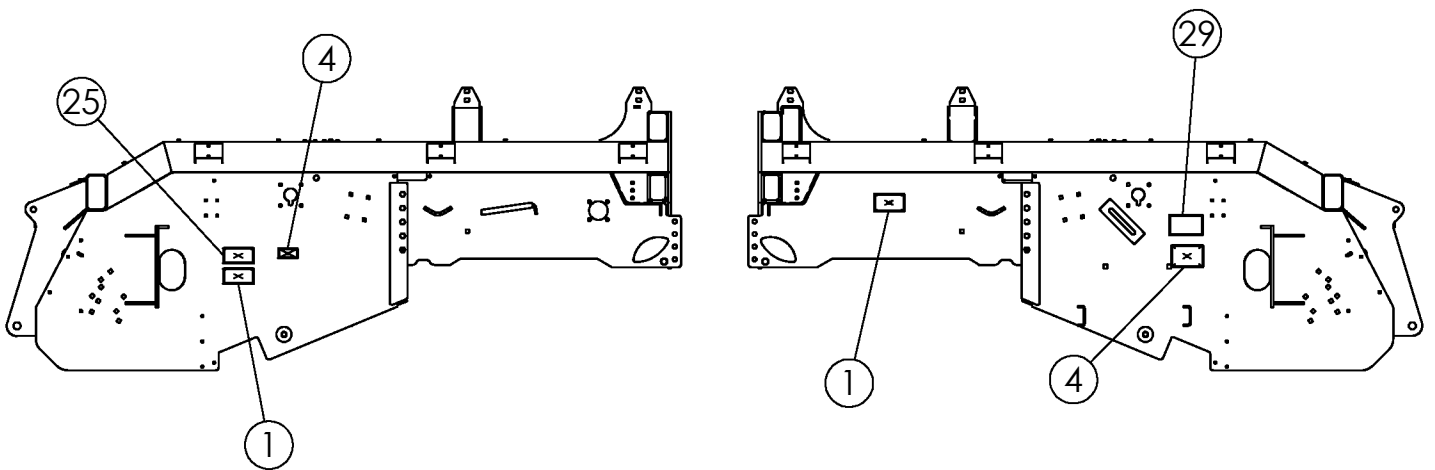
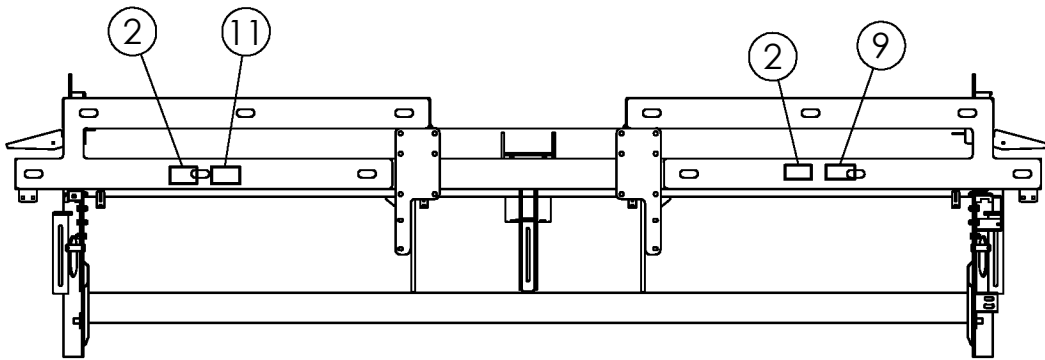
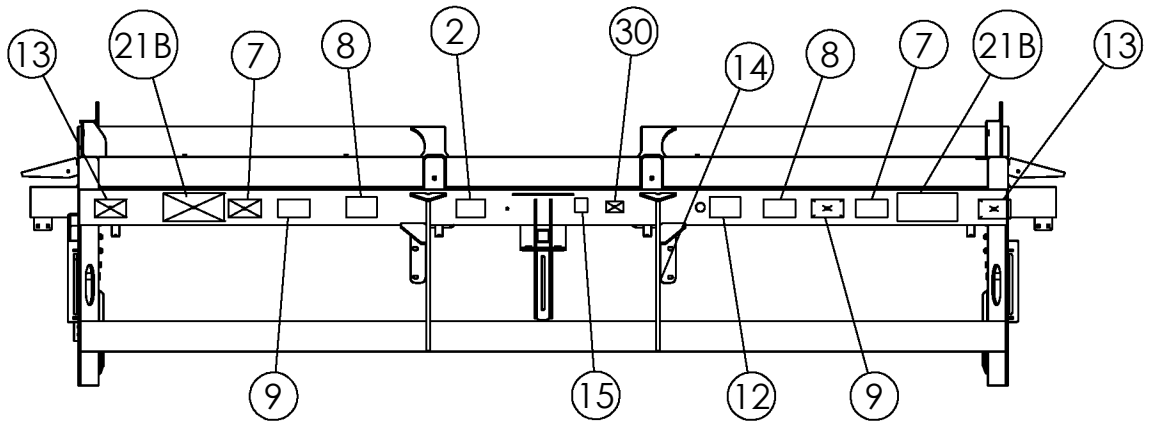

DECALS

1 303272 QTY 2

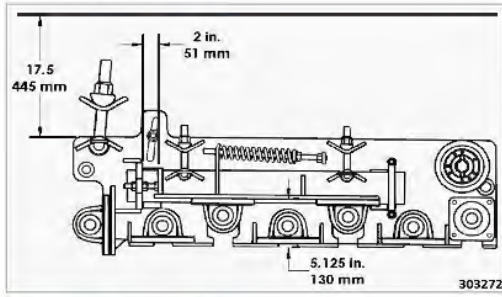

6 302992 QTY 1

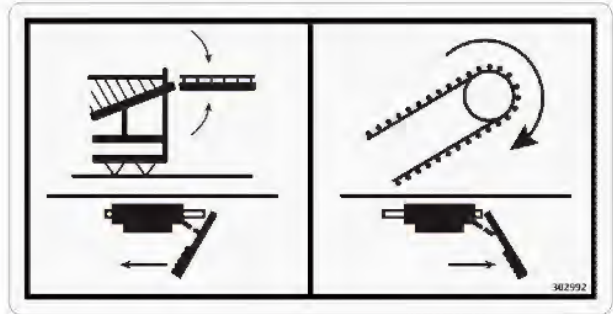

2 9971011 QTY 4



7 9971015 QTY 2



3 9971021 QTY 1



8 303263 QTY 2

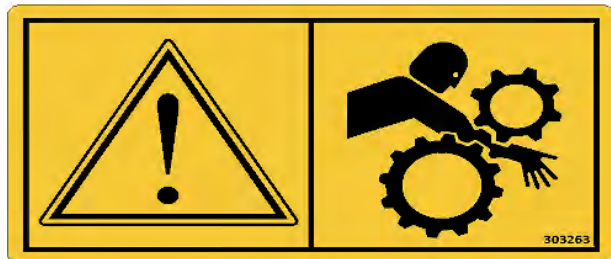

4 9971013 QTY 3

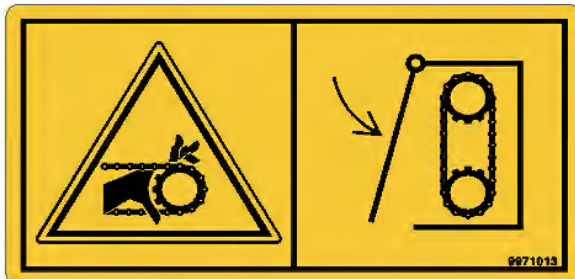

9 303268 QTY 5



5 9971025 QTY 1



CONTINUED

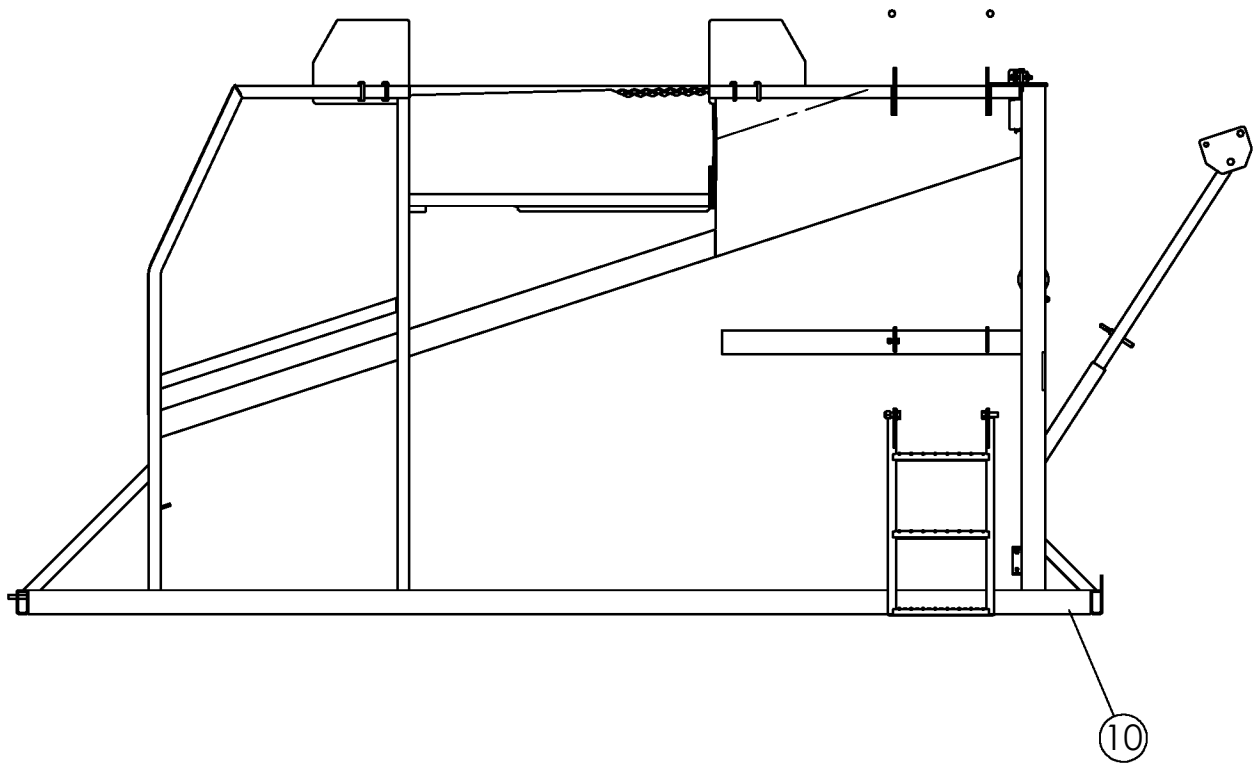
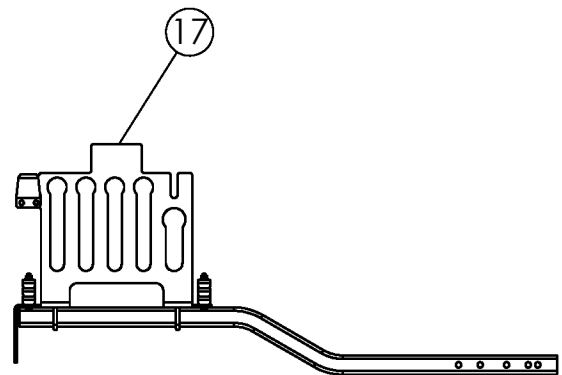
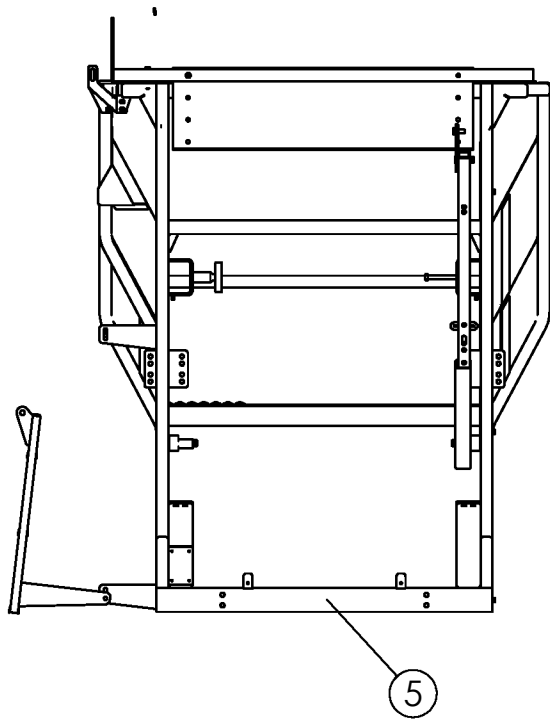

DECALS (CONTINUED)

10 303277 QTY 1



15 997867 QTY 2

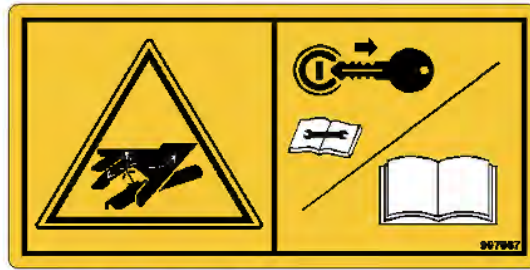

11 9971015 QTY 1



16 303269 QTY 2

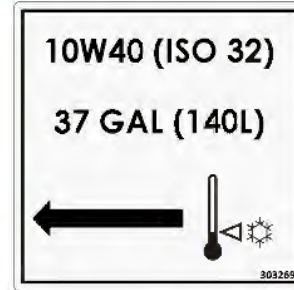

12 997861 QTY 1



17 303849 QTY 1

Hose Color Chart - 2300/2500		
Black	Hitch	or Fasse Valve
Blue	Row Finder Constant	
Yellow	Row Finder Override	
Green	Elevator	
Orange	Active Depth Control *	or Rear Lift
Red	Rear Steering	
Blue/ Yellow	Left Rear Steer	or Left Rear Lift
Red/ Green	Right Rear Steer	or Right Rear Lift
Green/ Yellow	Wheel or Scrub Drive	
Yellow/ Red	ADC and Row Finder Constant *	
*Case Drain Line Must Be Used When Using the ADC Valve		
*Load Sense Line Must Be Used When Using Power Beyond		

13 303265 QTY 2



14 997859 QTY 1



CONTINUED

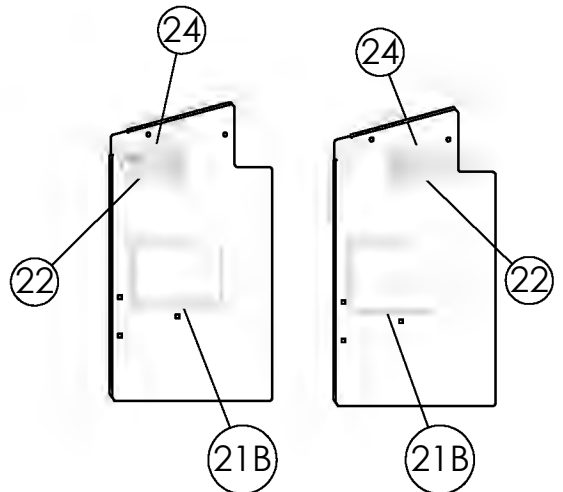
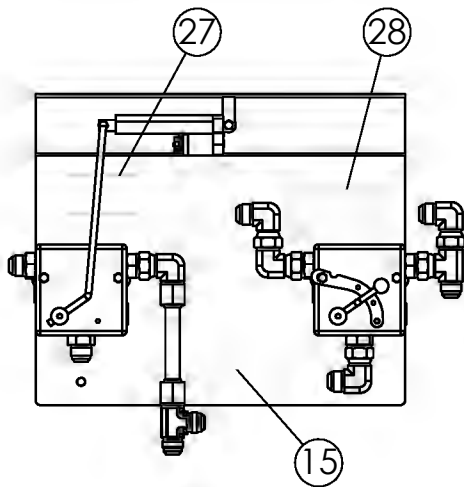
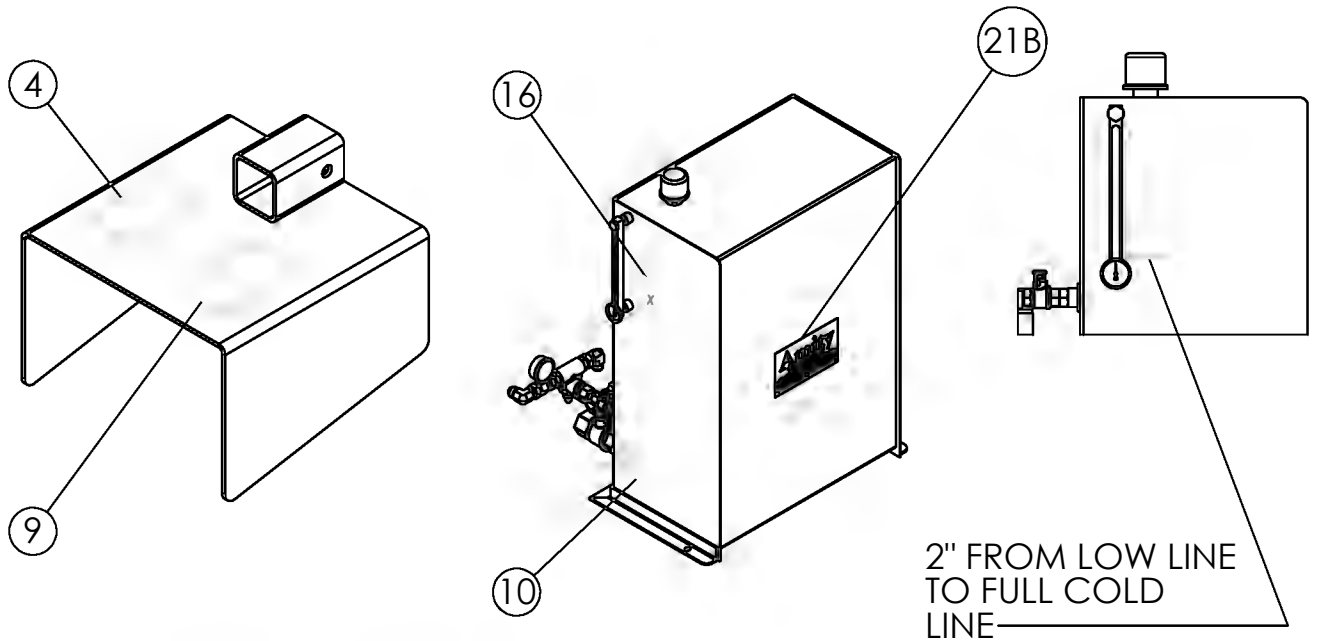
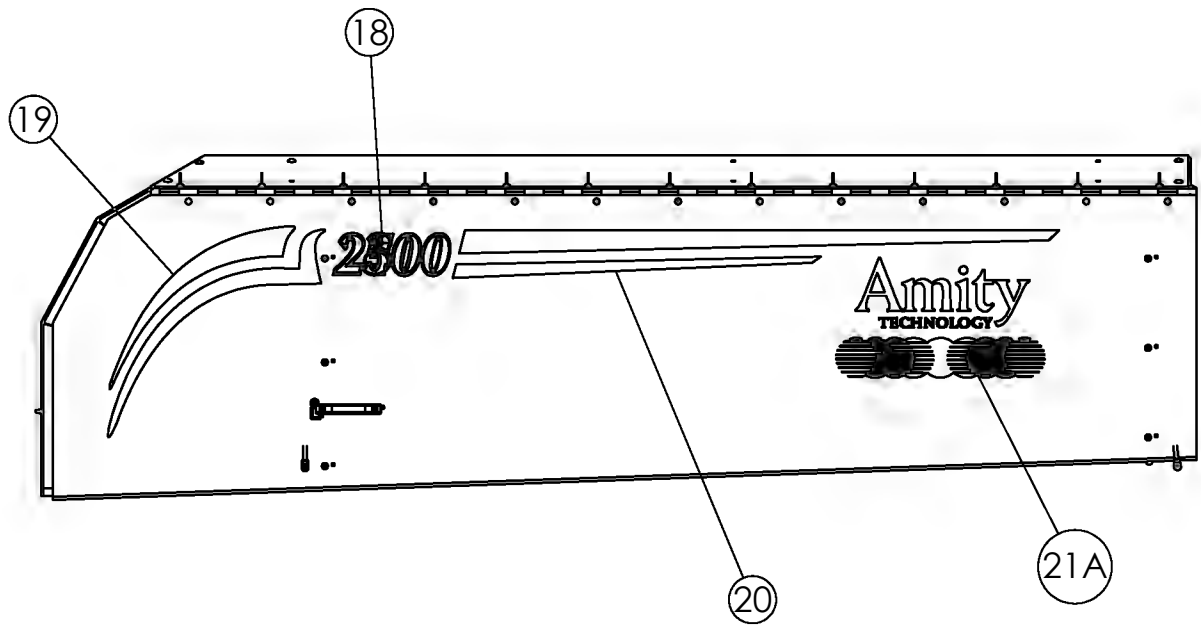

DECALS (CONTINUED)

18 69292 2500 QTY 1
 69291 2400
 69290 2300

21A 69399 QTY 2 LARGE LOGO
 21A 63465 QTY 5 SMALL LOGO

2400



19 69294 LH QTY 1
 69297 RH QTY 1 NOT SHOWN

22 65330 QTY 2

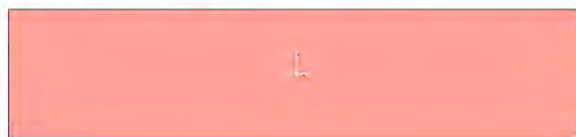
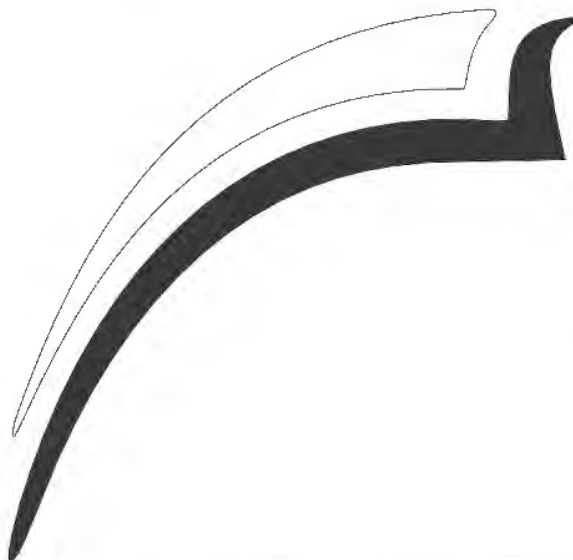

23 65331 QTY 4

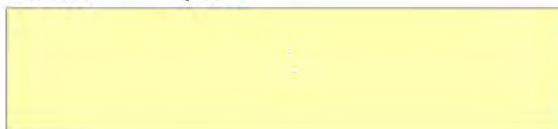

24 65332 QTY 2



20 69295 LH QTY 1 69298 RH NOT SHOWN QTY 1



25 62873 QTY 1

26 303264 QTY 1

Cleaning Bed Speed and Spring Adjustment

Spring Compression Adjustment				
B	13.50 In	34 cm		
C	8.50 In	22 cm		

Sheave A	Outside Diameter	Grabroll RPM	P/N (6R)	P/N (8R)
6.8"	7.15 In 182 mm	606	56647	57681
6.2	6.55 In 166 mm	552	56646	57680
5.6"	5.95 In 151 mm	500	53668	57679

* Available from your authorized WIC dealer

62873

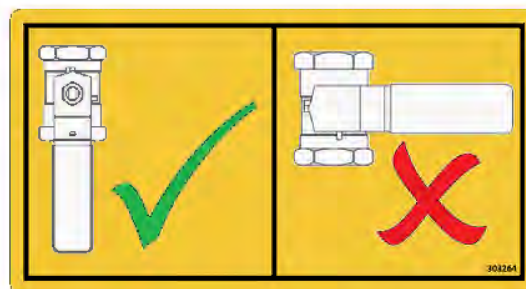

DECALS (CONTINUED)

27 303850 QTY 1

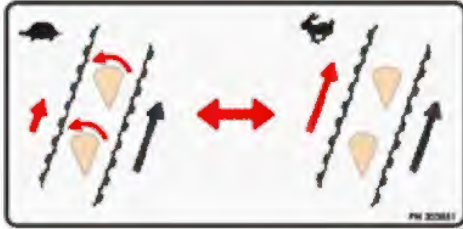

28 303851 QTY 1



29 303804 QTY 1

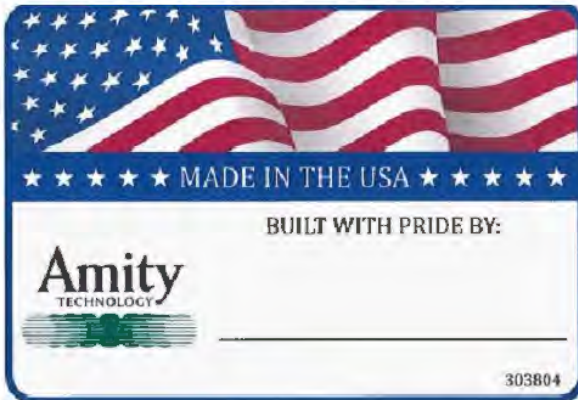

30 303769 QTY 1



INTENTIONALLY LEFT BLANK

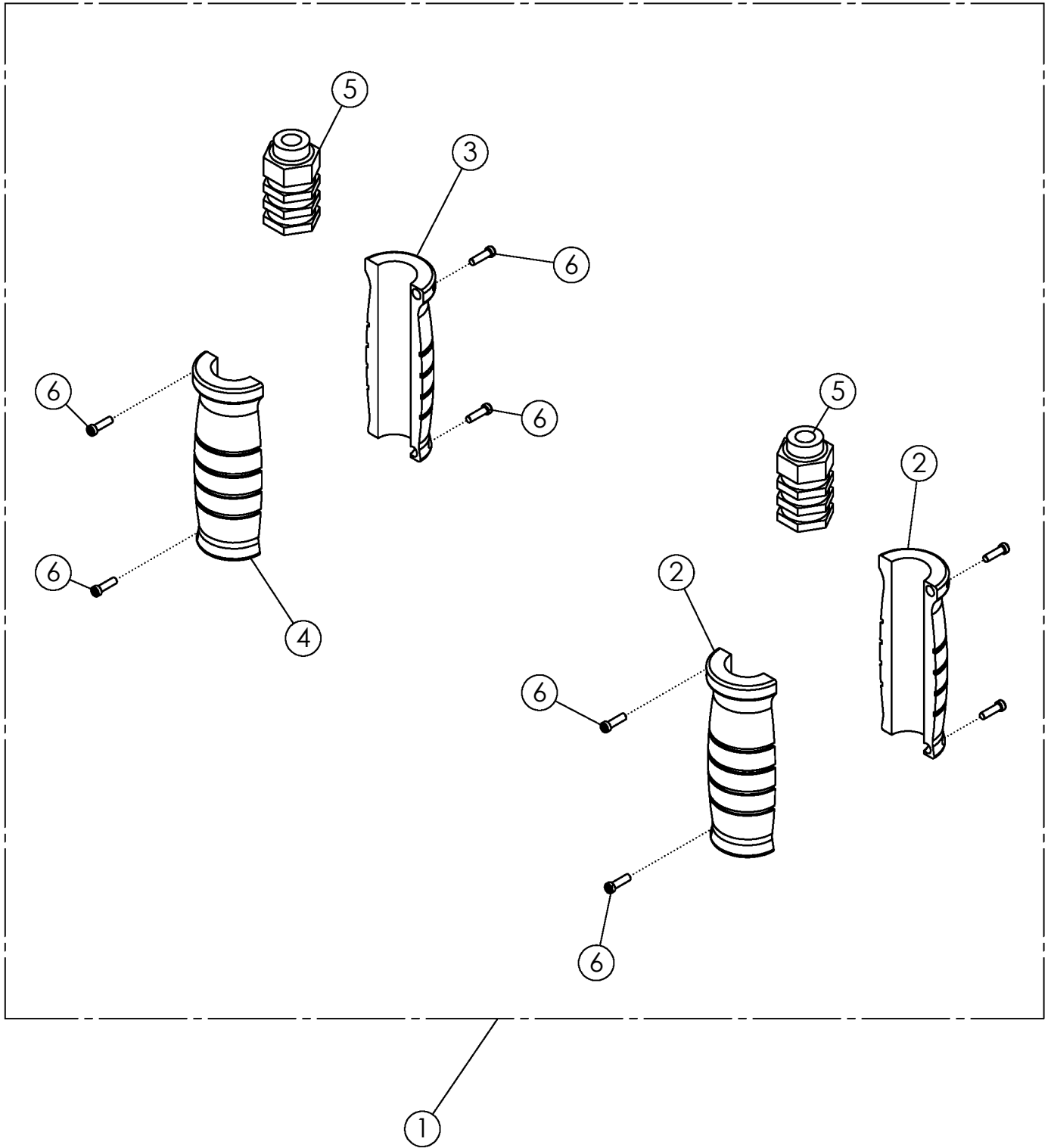

HYDRAULIC LABEL ASSY

ITEM	PART NO.	DESCRIPTION	QTY
1	301920*	HYD LABEL: .50 ORANGE/GRAY SET	1
	301902*	HYD LABEL: .50 BLUE/GRAY SET	
	301917*	HYD LABEL: .50 YELLOW/GRAY SET	
	301914*	HYD LABEL: .50 GREEN/GRAY SET	
	301911*	HYD LABEL: .50 BLACK/GRAY SET	
	301908*	HYD LABEL: .50 RED/GRAY SET	
	302230*	HYD LABEL: .50 RED/GREEN SET	
	302226*	HYD LABEL: .50 BLACK/ORANGE SET	
	302227*	HYD LABEL: .50 BLUE/YELLOW SET	
	301923*	HYD LABEL: .75 GREEN/GRAY SET	
	301928*	HYD LABEL: .75 YELLOW/GRAY SET	
2	301915	HYD LABEL: .50 GREEN HALF EXTEND	2
	301903	HYD LABEL: .50 BLUE HALF EXTEND	
	301909	HYD LABEL: .50 RED HALF EXTEND	
	301918	HYD LABEL: .50 YELLOW HALF EXTEND	
	301921	HYD LABEL: .50 ORANGE HALF EXTEND	
	301912	HYD LABEL: .50 BLACK HALF EXTEND	
	301921	HYD LABEL: .50 ORANGE HALF EXTEND	
	301925	HYD LABEL: .75 GREEN HALF EXTEND	
	301929	HYD LABEL: .75 YELLOW HALF EXTEND	
	302304	HYD LABEL: .75 RED HALF EXTEND	
3	301916	HYD LABEL: .50 GREEN HALF RETRACT	1
	301904	HYD LABEL: .50 BLUE HALF RETRACT	
	301910	HYD LABEL: .50 RED HALF RETRACT	
	301919	HYD LABEL: .50 YELLOW HALF RETRACT	
	301922	HYD LABEL: .50 ORANGE HALF RETRACT	
	301913	HYD LABEL: .50 BLACK HALF RETRACT	
	301922	HYD LABEL: .50 ORANGE HALF RETRACT	
	301926	HYD LABEL: .75 GREEN HALF RETRACT	
	301930	HYD LABEL: .75 YELLOW HALF RETRACT	
	302305	HYD LABEL: .75 RED HALF RETRACT	
4	301905	HYD LABEL: .50 GRAY HALF RETRACT	1
	301927	HYD LABEL: .75 GRAY HALF RETRACT	
5	301906	HYD LABEL: .50 CORE M & F O-RING	2
	301924	HYD LABEL: .75 CORE M & F O-RING	
6	301907	HYD LABEL: SET SCREW	8

* COMES WITH ITEMS 2 THRU 6