

PARTS MANUAL

2023

3300 DEFOLIATOR
EXPORT

6 ROW 56

6 ROW 50

6 ROW 45

Amity
TECHNOLOGY



2800 7th Avenue North
Fargo, ND 58102

Phone: (701) 232-4199

Fax: (701) 234-1716

www.amitytech.com

TABLE OF CONTENTS

HITCH ASSEMBLY	1-4
FRAME HARDWARE	5-6
DRIVE TRAIN	7-8
#1 FLAILS	9-10
#2 FLAILS	11-12
#3 FLAILS	13-14
FLAIL TUBE ASSEMBLY	15-16
FLAIL TUBE MOUNTING	17-18
FLAIL TUBE MOUNTING- STEEL FRONT DRUM OPTION	19-20
DOORS AND SHIELDS	21-24
STANDARD REAR STRUTS- 7.6 X 15 TIRES	25-26
STEERABLE REAR STRUTS- 7.6 X 15 TIRES	27-30
SCALPER BAR ASSEMBLY	31-32
SCALPER BASKET	33-34
SCALPER HYDRAULICS	35-36
LIGHT KIT	37-38
DECALS	39-42
GEARBOX-L TYPE (1.57:1) #52391, (1:1) #52392	43-44
GEARBOX- T TYPE (1:1.57) #52379, (1.57:1) #52393	43-44
GEARBOX- T TYPE (1:1 W OVERRUN) #59189	45-48
STANDARD PTO 38MM – 8 #69678	49-50
1-3/8” CONSTANT VELOCITY PTO #306403	51-52
1-3/4” CONSTANT VELOCITY PTO #306404	51-52
CLUTCH- TORQUE LIMITER #305196 (CV) #305198 (STD)	53-54
FRONT SIDE DRIVELINE #52399 & #68604	55-56
SIDE DRIVELINE #52397	55-56
HYDRAULIC LABEL ASSY	57-58
SNAP RING PLIERS	59

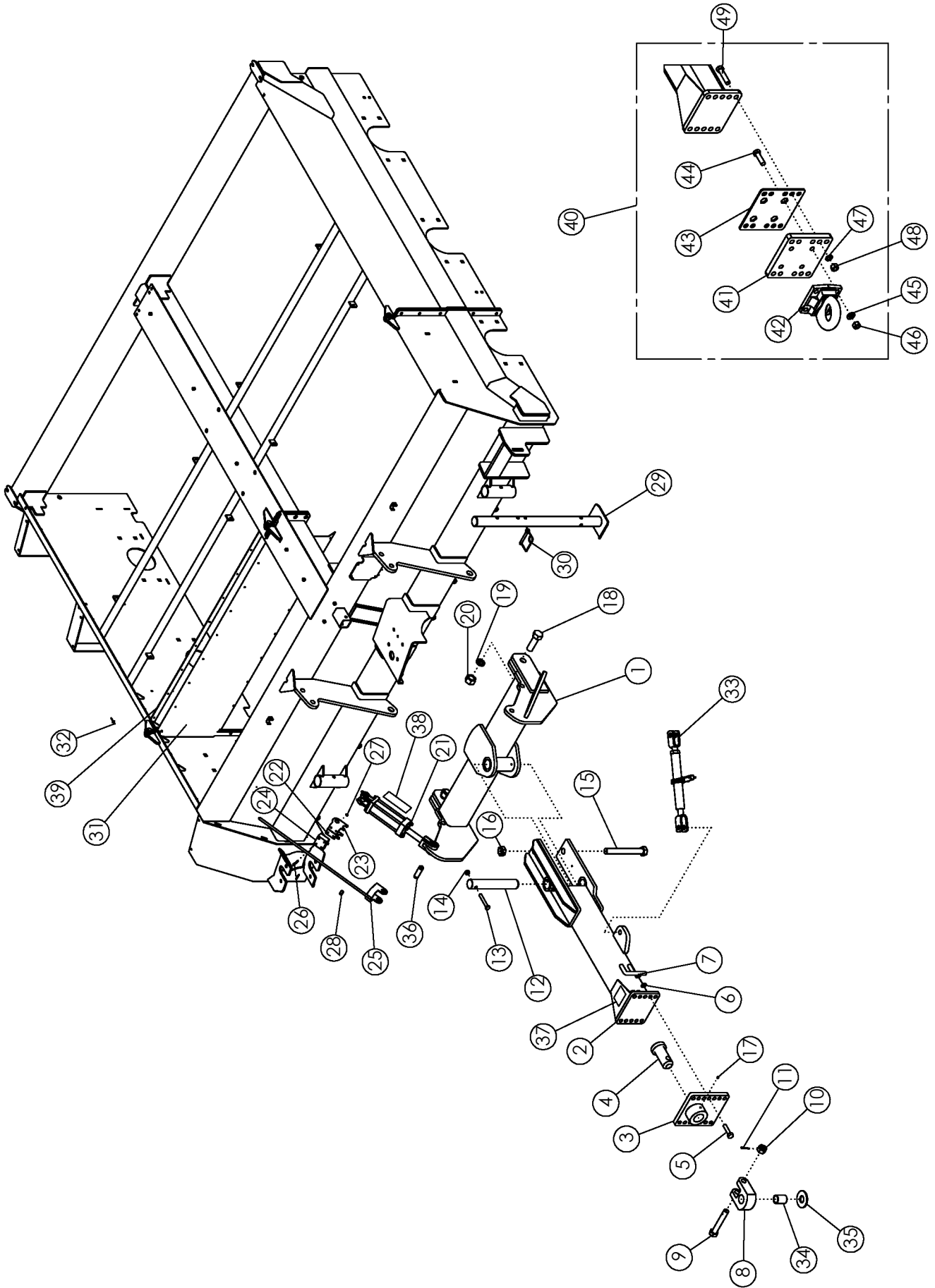

HITCH ASSEMBLY			
ITEM	PART NO.	DESCRIPTION	QTY
1	50341	WLDMT - STD HITCH PIVOT	1
2	68277	WLDMT - DRAWPOLE DEF	1
3	57930	WLDMT-HITCH PLATE	1
4	62101	WLDMT-PIN	1
5	1012059	BOLT-HEX: .75 X 3.00 NC GR5 ZP	6
6	1012061	WASHER-LOCK: .75 ZP	6
7	1011620	NUT-HEX: .75 NC GR2 ZP	6
8	64476	PLATE-PULL HITCH	1
9	62477	BOLT-HITCH DRILLED	1
10	62088	NUT-SLOTTED: 1.13 NC GR5 ZP	1
11	1013473	PIN-COTTER: .19 X 2.00 ZP	1
12	50678	PIN	1
13	1015117	BOLT-HEX: .63 X 4.00 NC GR8 ZP	1
14	1016595	NUT-TOPLOCK: .63 NC GR5 ZP	1
15	1030756	BOLT-HEX: 1.25 X 10.50 NC GR5 ZP	1
16	1030759	NUT-TOPLOCK: 1.25 NC ZP	1
17	1011748	ZERK - GREASE: .25 UNF STRAIGHT	4
18	1030757	BOLT-HEX: 1.38 X 4.25 NC GR5 ZP	2
19	1030760	WASHER-LOCK: 1.38 ZP	2
20	1030758	NUT-HEX: 1.38 NC ZP	2
21	58891	CYLINDER-HYDRAULIC 4 X 8" 3000	2
	59244	SEAL KIT FOR 58891	
22	63995	TOP_BRACKET - RH	1
23	63996	TOP_BRACKET - LH	1
24	63383	POLY GUIDE BLOCK	1
25	63999	WLDMT - BOTTOM_BRACKET	1
26	1016211	BOLT-HEX: .25 X 2.00 NC GR5	4
27	1030946	NUT-TOPLOCK: .25 NC GR5 ZP	4
28	63359	COLLAR-SET: .56 ZP	1
29	52073	WLDMT-STAND	2
30	52408	SPRING PIN: .50 X 3.50	2
31	305029	LINER-FRONT	2
32	56886	RIVET-POP: .19 X .675 ZP	44
33	52407	RATCHET JACK-PAINTED	1
34	64615	TUBE-SPACER 2.00 X 1.25	1
	64614	TUBE-SPACER 2.00 X 1.63	
35	58925	WASHER-HARDENED: 4.00 X 1.63	1
	68645	WASHER-FLAT: 2.000 ZP GR8	
36	63406	PIN-CLEVIS: 1.00 X 4.00 ZP	2
37	52448R	DECAL-CAUTION	1

CONTINUED

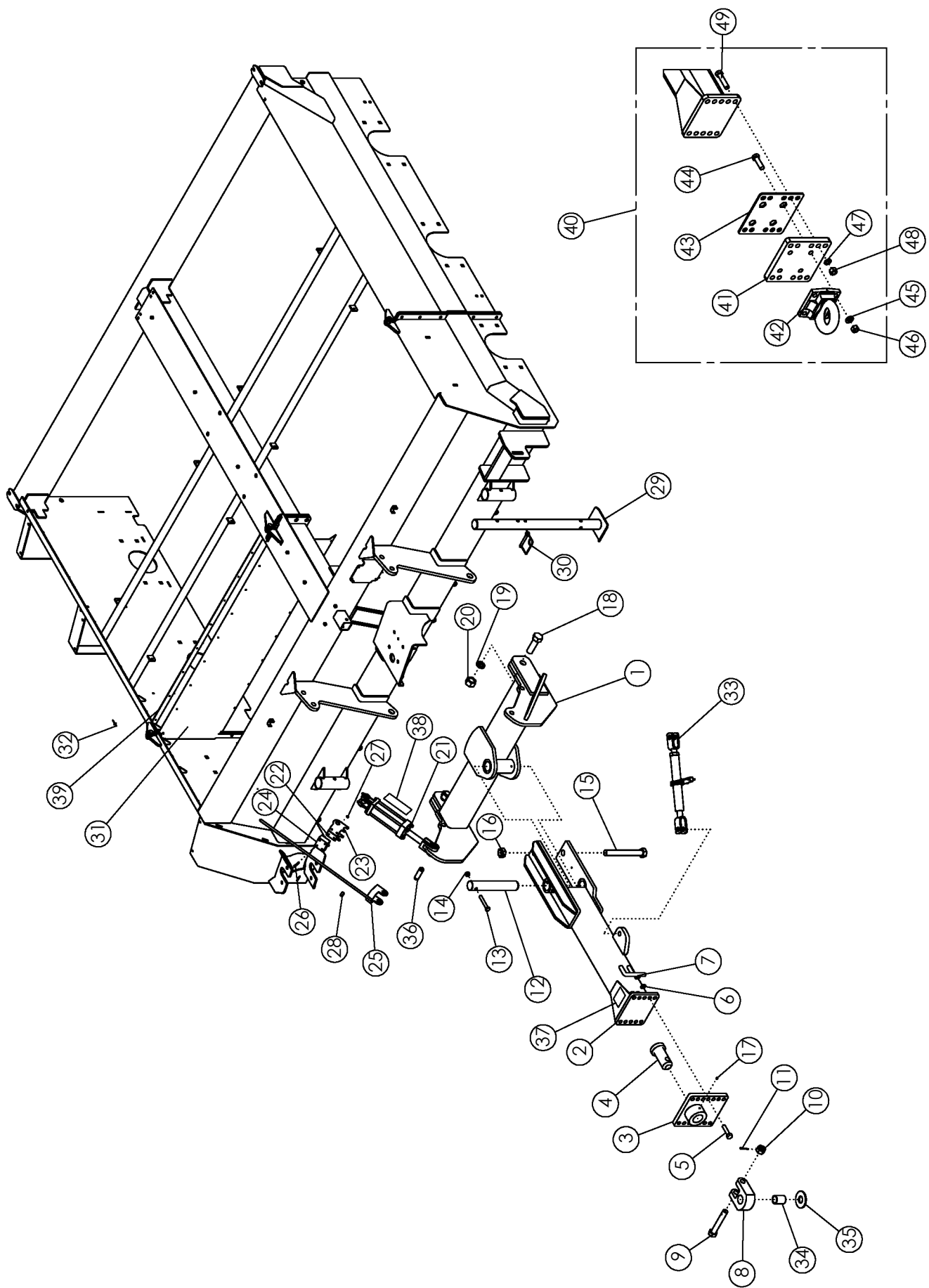

PINTLE HITCH (CONTINUED)			
38	63405	DECAL-DEPTH GAUGE	1
39	305036	STRIP-LINER BACK 6R	2
40	69057	KIT-PINTLE HITCH	1
41	64201	PLATE - MOUNT	1
42	64200	HITCH-PINTLE	1
43	64254	PLATE - MOUNT	1
44	62096	BOLT-HEX: .75 X 2.50 NC GR8 ZP	4
45	1021584	WASHER-FLAT: SAE .75 ZP	4
46	1011434	NUT-TOPLOCK: .75 NC GR8 ZP	4
47	1012061	WASHER-LOCK: .75 ZP	6
48	1011620	NUT- HEX: .75 NC	6
49	1032271	BOLT-HEX: .75 X 3.25 NC GR5 ZP	6

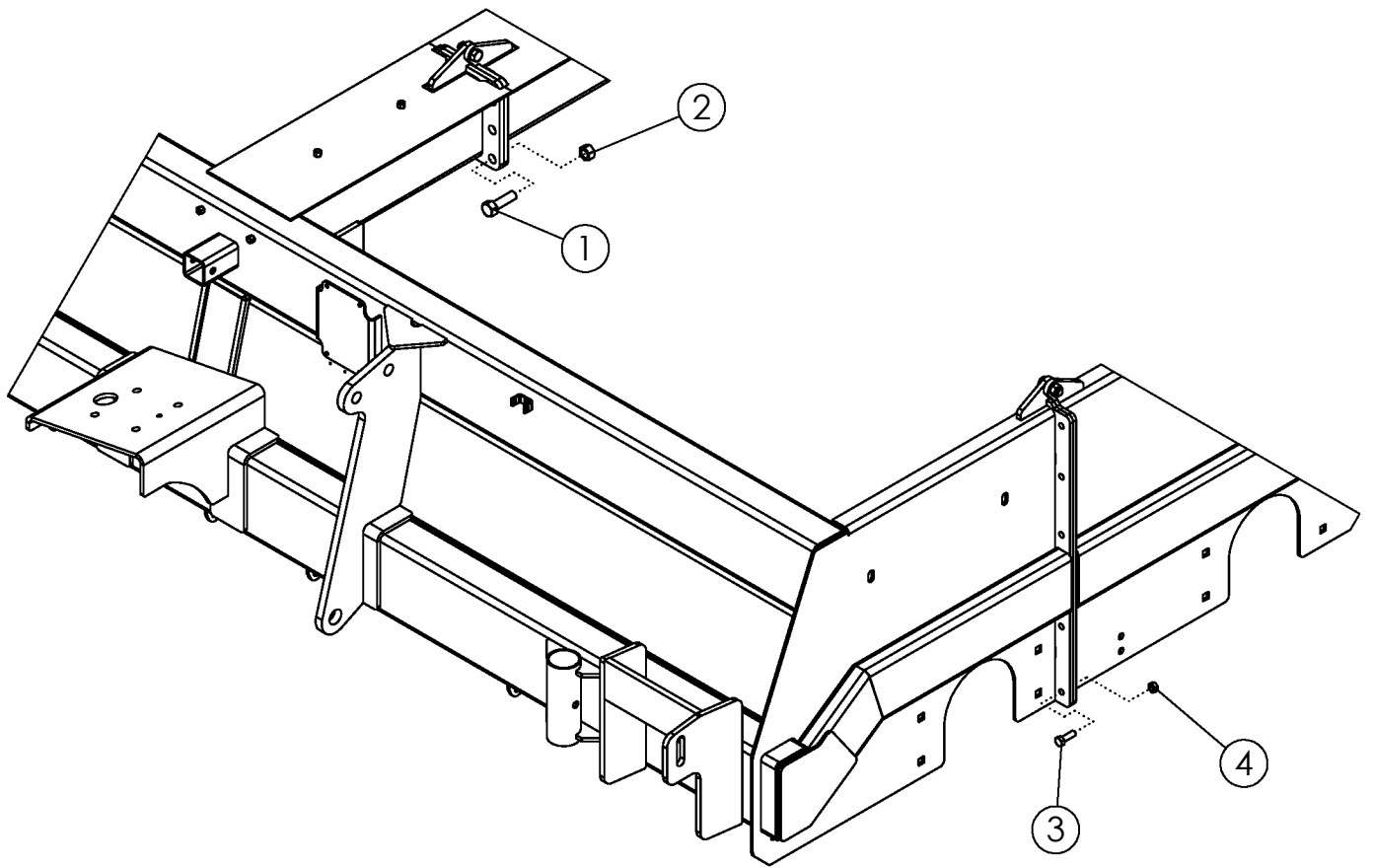

FRAME HARDWARE

ITEM	PART NO.	DESCRIPTION	QTY
1	1016598	BOLT- HEX: .75 X 2.50 NC GR5 ZP	6
2	1017000	NUT-TOPLOCK: .75 NC GR5 ZP	6
3	1011607	BOLT-HEX: .50 X 1.50 NC GR5 ZP	22
4	1027461	NUT-TOPLOCK: .50 NC GR5 ZP	22

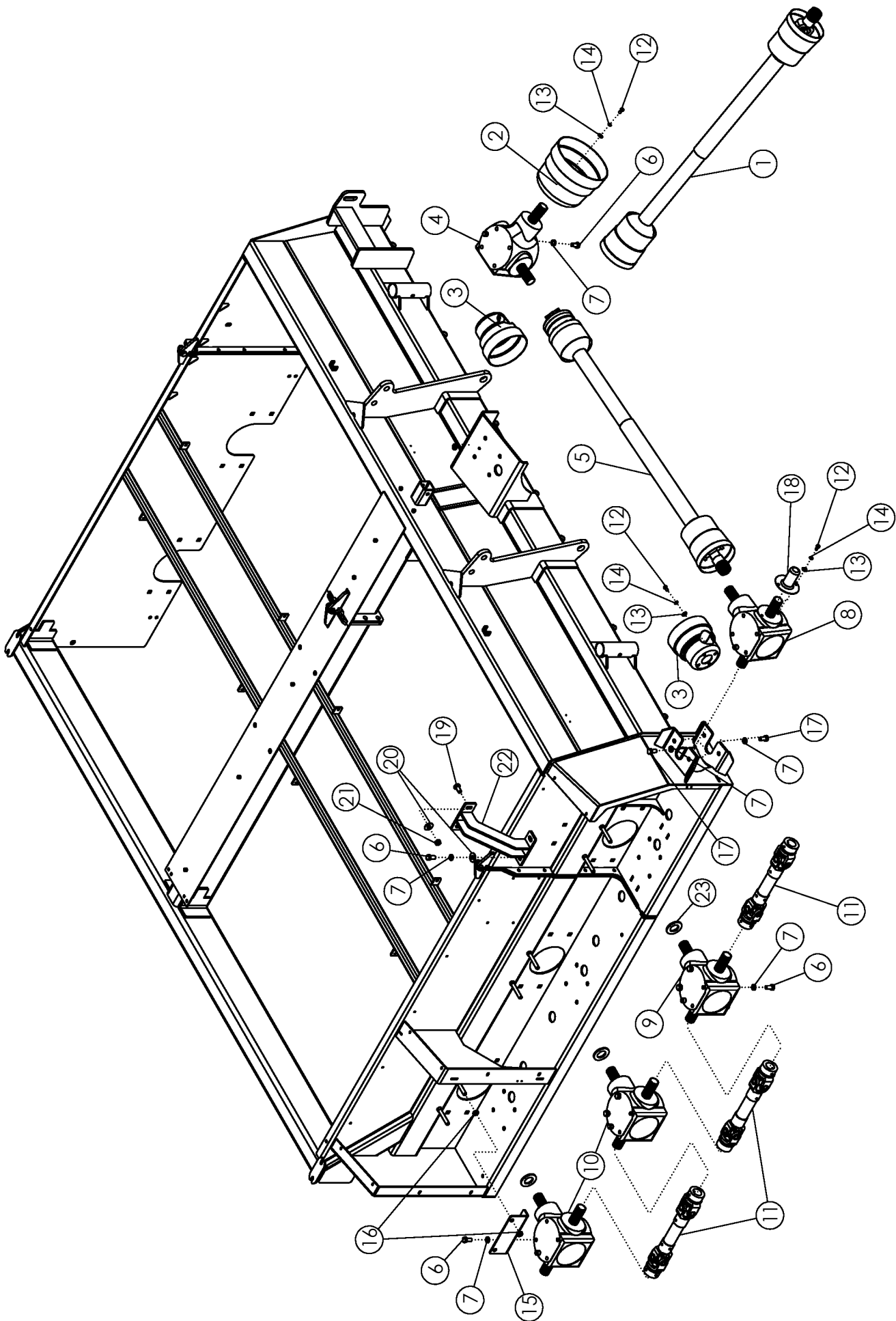

DRIVE TRAIN

ITEM	PART NO.	DESCRIPTION	QTY
1	306402	PTO-STD 38MM-8 (DEF)	1
	306404	PTO-STD 1-3/8"-21	
	306403	PTO-STD 1-3/4"-20	
2	52389	SHIELD CONE-LARGE	1
3	63972	SHIELD-CONE SMALL DRILLED	2
4	52391	GEARBOX 1.57:1 2WAY	1
5	52399	CROSS SHAFT	1
6	1030703	BOLT-HEX: .63 X 1.25 NF GR5 ZP	24
7	1011813	WASHER-LOCK: .63 ZP	28
8	59189	GEARBOX 1:1 2 WAY W/CLUTCH	1
9	52393	GEARBOX 1.57:1 (NON-STEEL FLAIL)	1
	52379	GEARBOX 1:1.57 (STEEL FLAIL)	1
10	52393	GEARBOX 1.57:1	2
11	52397	DRIVELINE-SIDE	3
12	1011599	BOLT-HEX: .38 X .75 NC GR5 ZP	14
13	1011828	WASHER-FLAT: .38 ZP	14
14	1011586	WASHER-LOCK: .38 ZP	14
15	57020	ANGLE	3
16	1026259	NUT-JAM: .63 NC GR2 ZP	12
17	1032509	BOLT-HEX: .63 X 1.25 NC GR5 ZP	4
18	59762	COVER-SHAFT	1
19	72063	BOLT-CRG: .63 X 1.50 NC GR5 ZP	2
20	1013024	WASHER-FLAT: .63 ZP	4
21	1016595	NUT-TOPLOCK: .63 NC GR5 ZP	2
22	305193	WLDMT-GEARBOX SUPPORT 6R	1
23	306388	RUBBER-FLAIL TUBE SPACER	3

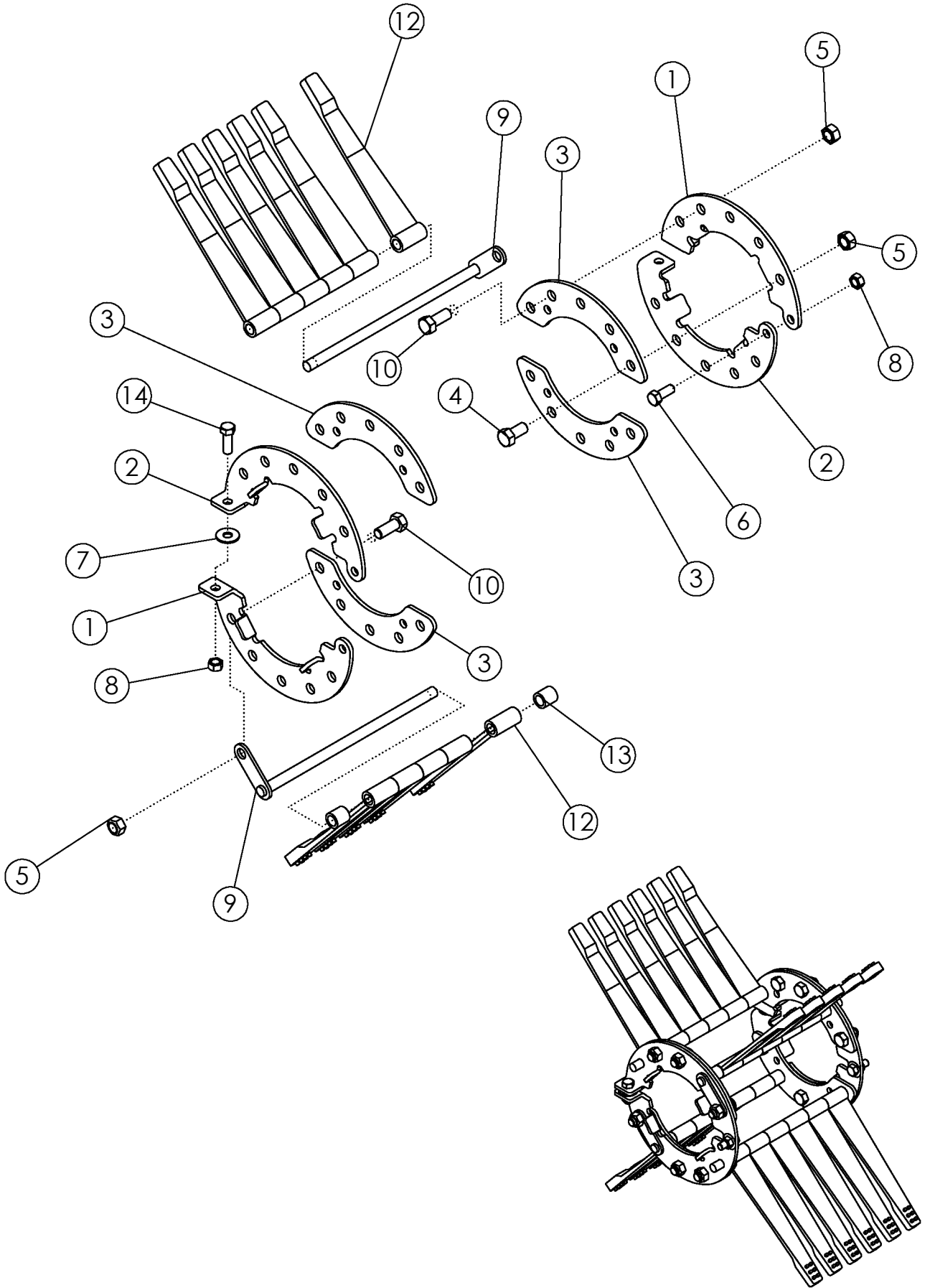

**RUBBER FLAILS ON #1 DRUM FORWARD
22" SPACING (#52123)**

ITEM	PART NO.	DESCRIPTION	QTY
1	52062	FLAIL RING-LH	2
2	52061	FLAIL RING-RH	2
3	58084	PLATE-REINFORCEMENT ZP	4
4	1032509	BOLT-HEX: .63 X 1.25 NC GR5 ZP	8
5	1016595	NUT-TOPLOCK: .63 NC GR5 ZP	12
6	1011606	BOLT-HEX: .50 X 1.25 NC GR5 ZP	2
7	1014443	WASHER-FLAT: .50 ZP	2
8	1027461	NUT-TOPLOCK: .50 NC GR5 ZP	4
9	305557	FLAIL ROD	4
10	1014349	BOLT-HEX: .63 X 1.50 NC GR5 ZP	4
11	1013024	WASHER-FLAT: .63 ZP	4
12	52356	FLAIL-STUDDDED 1 X 12	22
13	51549	SPACER 1	4
14	1011607	BOLT-HEX: .50 X 1.50 NC GR5 ZP	2

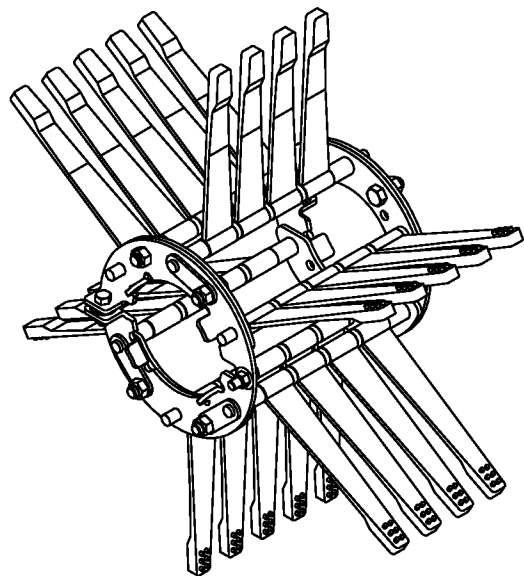
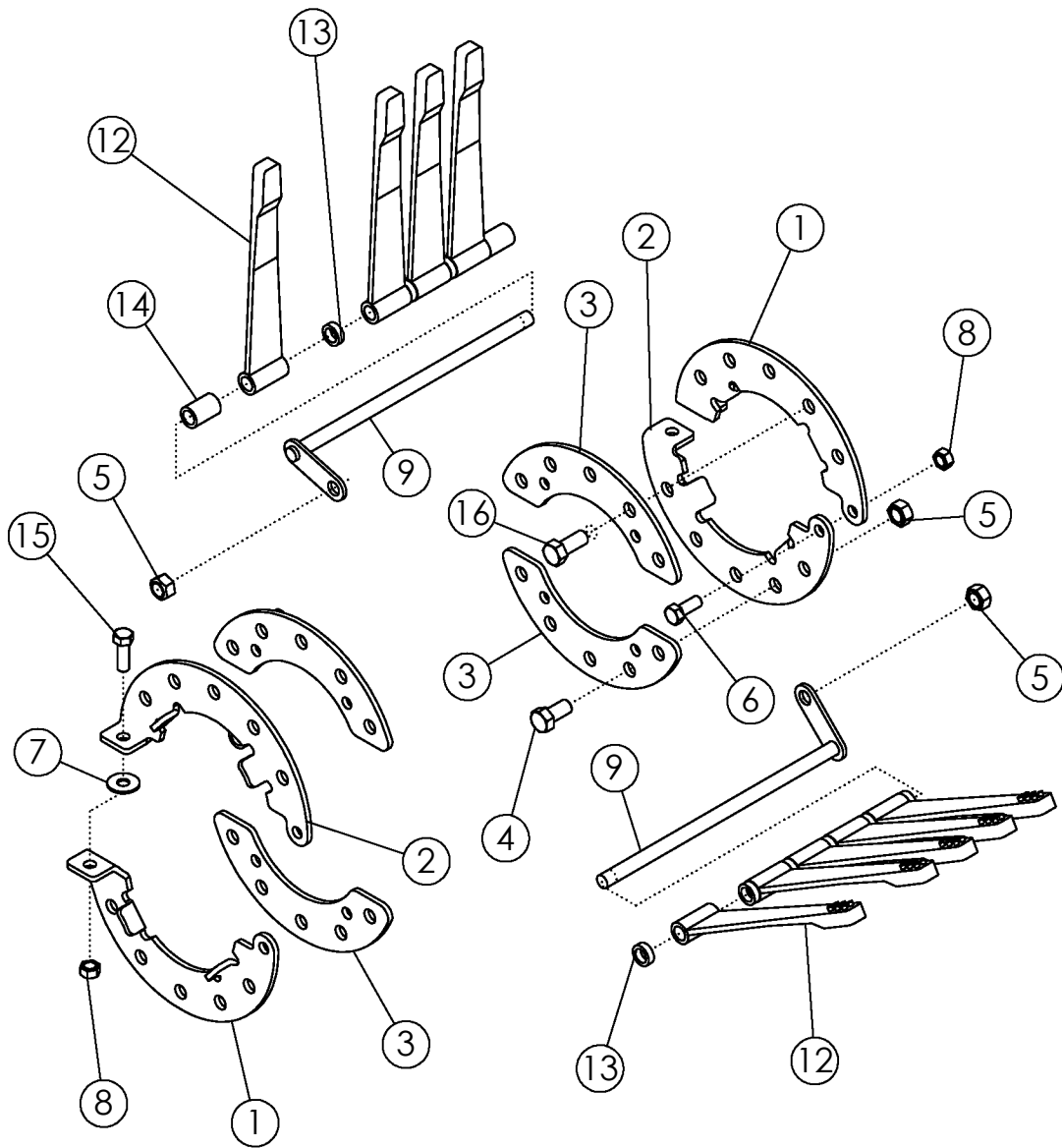

FLAILS ON #2 DRUM

ITEM	PART NO.	DESCRIPTION	QTY
1	52062	FLAIL RING-LH	2
2	52061	FLAIL RING-RH	2
3	58084	PLATE-REINFORCEMENT ZP	4
4	1032509	BOLT-HEX: .63 X 1.25 NC GR5 ZP	2
5	1016595	NUT-TOPLOCK: .63 NC GR5 ZP	8
6	1011606	BOLT-HEX: .50 X 1.25 NC GR5 ZP	2
7	1014443	WASHER-FLAT: .50 ZP	2
8	1027461	NUT-TOPLOCK: .50 NC GR5 ZP	4
9	305557	FLAIL ROD	6
10	1011623	BOLT-HEX: .63 X 2.00 NC GR5 ZP	6
11	1013024	WASHER-FLAT: .63 ZP	6
12	52356	FLAIL-STUDDDED 1 X 12	27
	52354	FLAIL-RUBBER 1 X 12 (PREMIER)	27
13	51547	SPACER 5/16	27
14	51548	SPACER 1-7/16	6
15	1011607	BOLT-HEX: .50 X 1.50 NC GR5 ZP	2
16	1014349	BOLT-HEX: .63 X 1.50 NC GR5 ZP	6

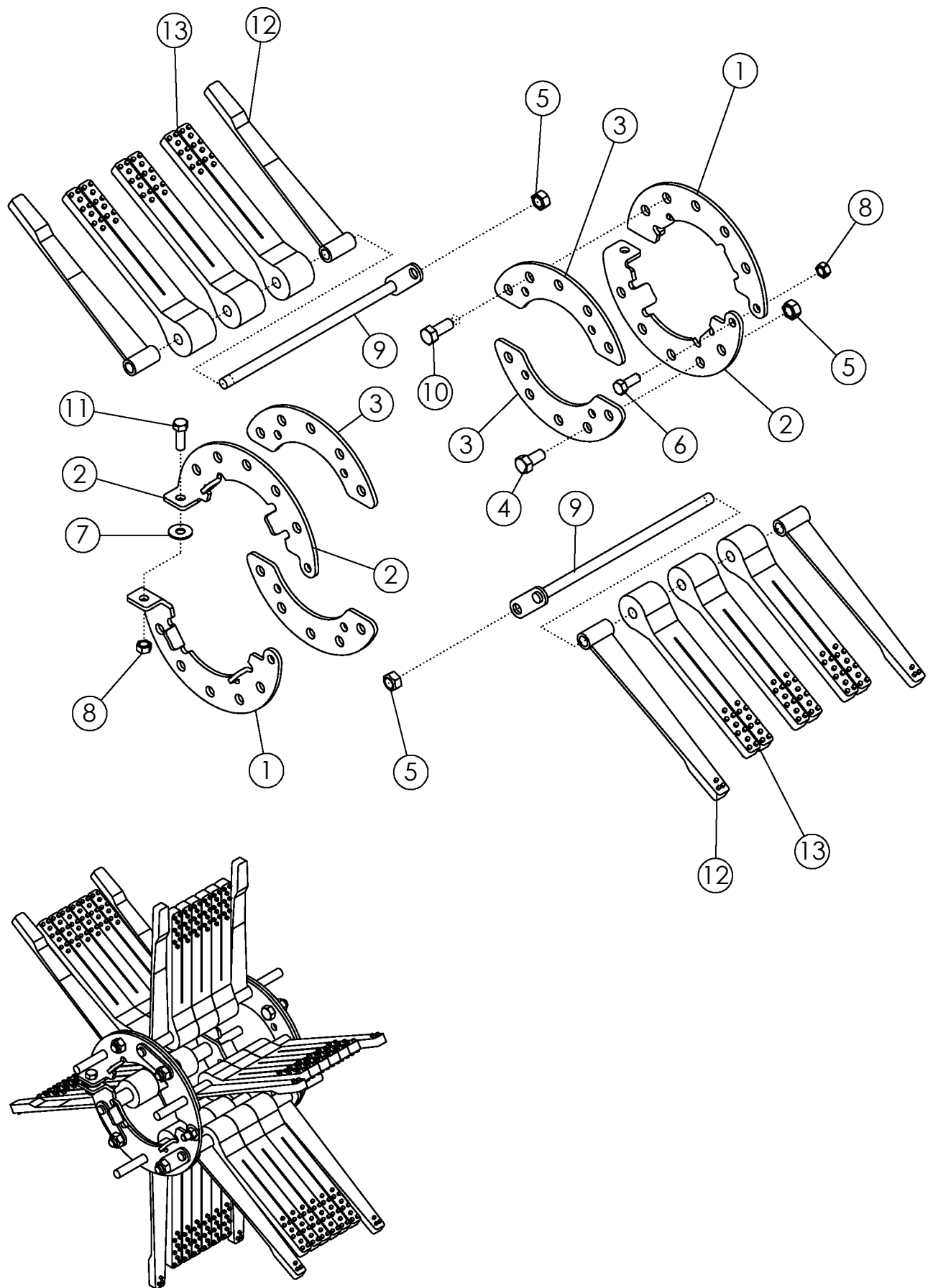

FLAILS ON #3 DRUM

ITEM	PART NO.	DESCRIPTION	QTY
1	52062	FLAIL RING-LH	2
2	52061	FLAIL RING-RH	2
3	58084	PLATE-REINFORCEMENT ZP	4
4	1032509	BOLT-HEX: .63 X 1.25 NC GR5 ZP	2
5	1016595	NUT-TOPLOCK: .63 NC GR5 ZP	8
6	1011606	BOLT-HEX: .50 X 1.25 NC GR5 ZP	2
7	1014443	WASHER-FLAT: .50 ZP	2
8	1027461	NUT-TOPLOCK: .50 NC GR5 ZP	4
9	305557	FLAIL ROD	6
10	1014349	BOLT-HEX: .63 X 1.50 NC GR5 ZP	6
11	1011607	BOLT-HEX: .50 X 1.50 NC GR5 ZP	2
12	52355	FLAIL-SWEEP 1 X 13-1/4	12
13	58255	FLAIL-SPLIT TAPER 2 X 12	18
	52356	FLAIL-STUDDER 1 X 12	18

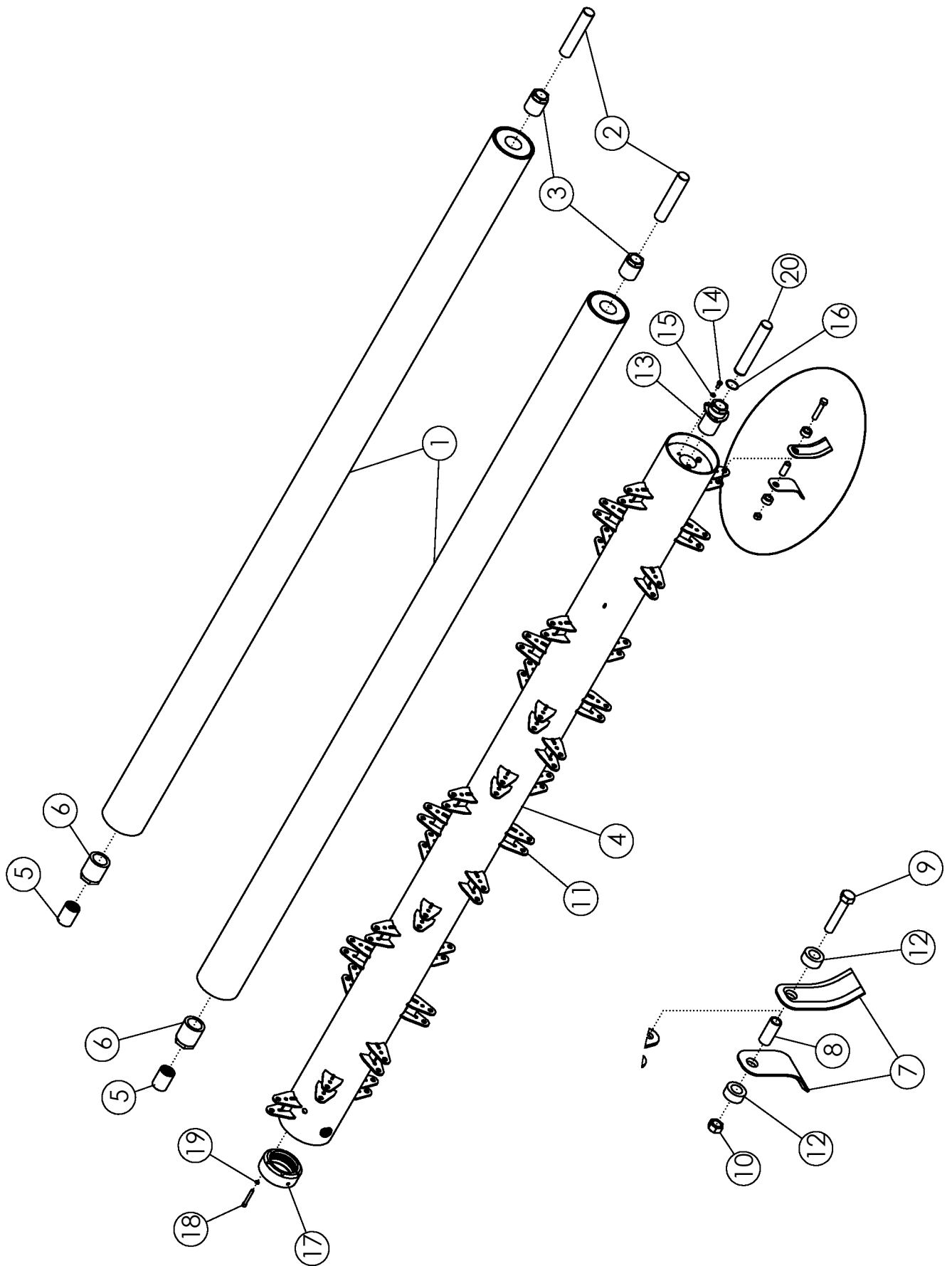

FLAIL TUBE ASSEMBLY

ITEM	PART NO.	DESCRIPTION	QTY
1	62124*	FLAIL TUBE #1, #2, & #3	2
2	58710	SHAFT-FLAIL TUBE	3
3	58459	HUB-TRANTORQUE 1.75 HD	3
4	307528	ASSY-DRUM L-FLAIL 8.5" 6R22 BAL	1
5	62150	COUPLER-SPLINED 1.75-20 X 2.25	3
6	59259	HUB-TRANTORQUE 2.25	3
7	307236	FLAIL-STEEL 5.31" LONG	68
8	68427	BUSHING-L KNIFE	34
9	65825	BOLT-HEX: .63 X 2.75 NC GR5 ZP	34
10	1016595	NUT-TOPLOCK: .63 NC GR5 ZP	34
11	68400	HOLDER-STEEL FLAIL	34
12	68426	SPACER-POLYURETHANE L KNIFE	68
13	64163	HUB-TRANTORQUE 1.750 X 3.375	1
14	1011599	BOLT-HEX: .38 X .75 NC GR5 ZP	3
15	1011586	WASHER-LOCK: .38 ZP	3
16	64184	RING-RETAINING 1.750	1
17	68412	COUPLER-DRIVE SLEEVE	1
18	68417	SCREW: S-H-CAP .38 X 2.75 NC GR8	6
19	68418	WASHER-LOCK: .38 HIGH COLLAR	6
20	68445	SHAFT-IDLER	1

*QUANTITY OF 3 ON A NON-STEEL FRONT DRUM

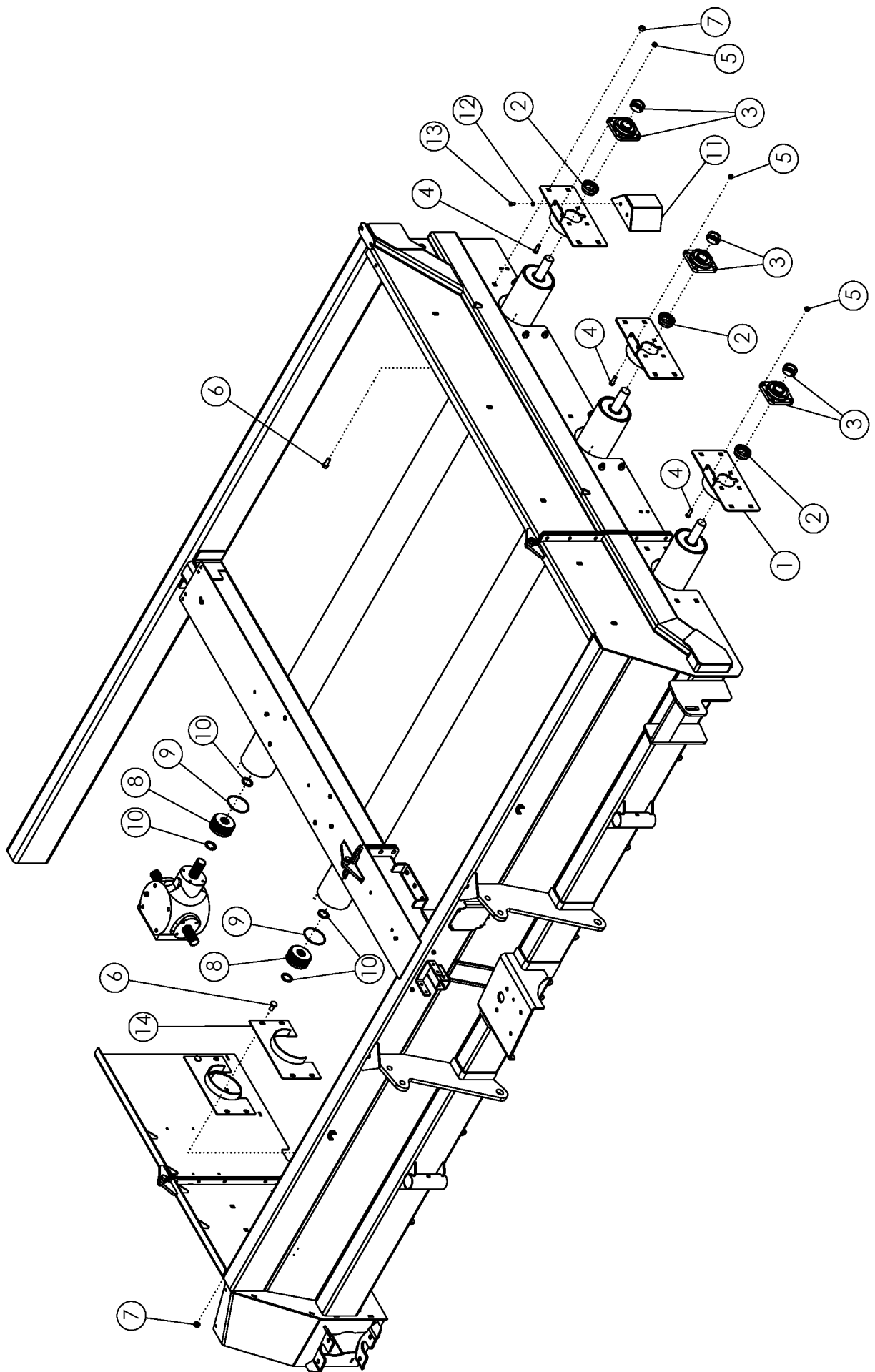

FLAIL TUBE MOUNTING

ITEM	PART NO.	DESCRIPTION	QTY
1	68244	COUPLER-DRIVE	3
2	52382	SEAL PROTECTOR 1.75	3
3	52404	BEARING-FLANGE 1.75	3
4	1011660	BOLT-CRG: .50 X 1.50 NC GR5 ZP	12
5	1027461	NUT-TOPLOCK: .50 NC GR5 ZP	12
6	72063	BOLT-CRG: .63 X 1.50 NC GR5 ZP	24
7	1016595	NUT-TOPLOCK: .63 NC GR5 ZP	24
8	68413	COUPLER-DRIVE	3
9	68414	O-RING 70 BUNA	3
10	68415	SNAP RING	6
11	68462	WLDMT-IDLER SHIELD	3
12	1011586	WASHER-LOCK: .38 ZP	6
13	1011599	BOLT-HEX: .38 X .75 NC GR5 ZP	6
14	51809	WLDMT-SHIELD ANTI-WRAP	3

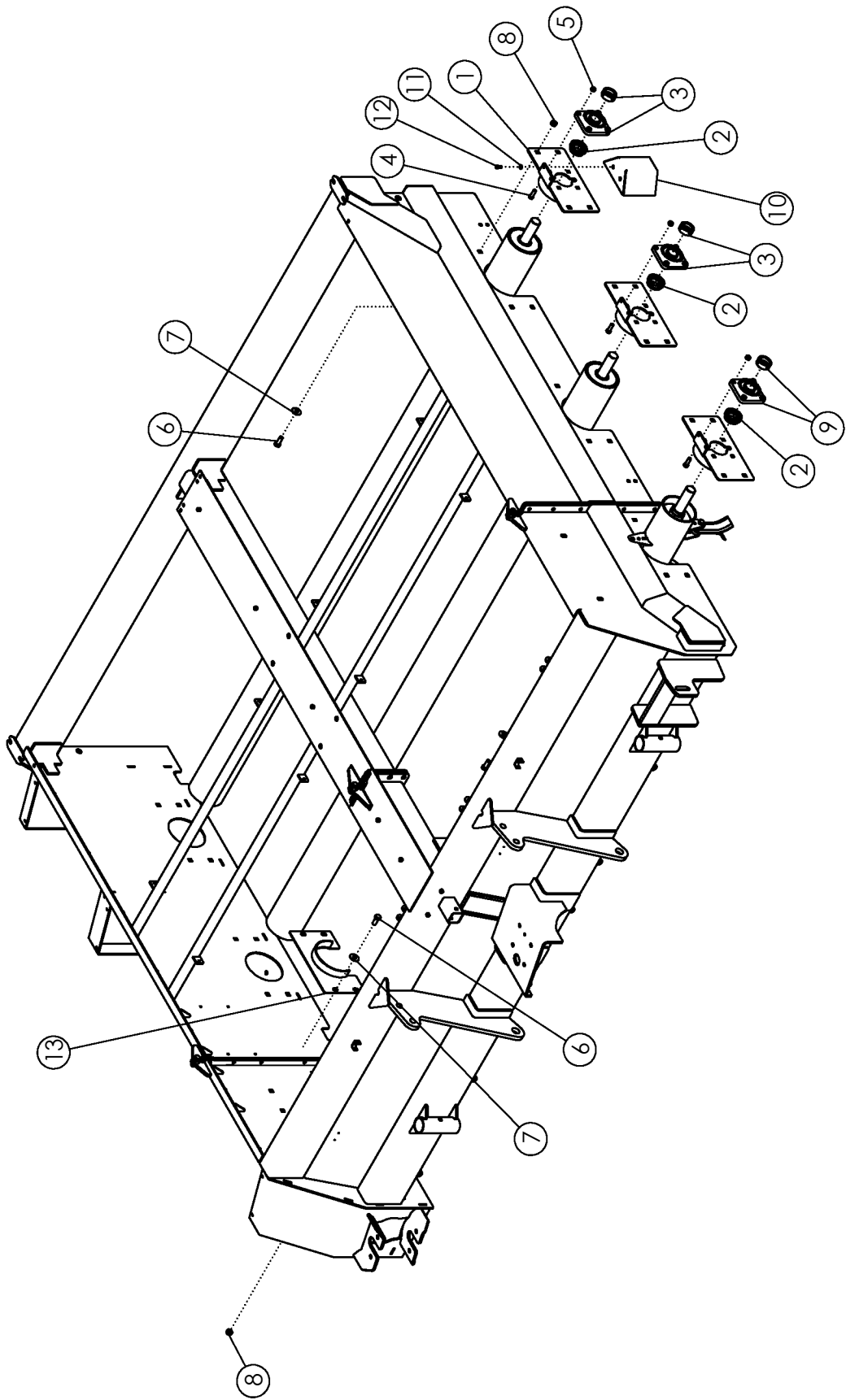

FLAIL TUBE MOUNTING - STEEL FRONT DRUM OPTION

ITEM	PART NO.	DESCRIPTION	QTY
1	68244	WLDMT-BEARING PLATE	3
2	52382	SEAL PROTECTOR 1.75	3
3	52404	BEARING-FLANGE 1.75	2
4	1011607	BOLT-HEX: .50 X 1.50 NC GR5 ZP	12
5	1027461	NUT-TOPLOCK: .50 NC GR5 ZP	12
6	1014349	BOLT-HEX: .63 X 1.50 NC GR5 ZP	16
7	1013024	WASHER-FLAT: .63 ZP	16
8	1016595	NUT-TOPLOCK: .63 NC GR5 ZP	16
9	306999	ASSY-BEARING-FLANGE 1-3/4" N-SEAL (STEEL)	1
10	68462	WLDMT-IDLER SHIELD	3
11	1011586	WASHER-LOCK: .38 ZP	6
12	1011599	BOLT-HEX: .38 X .75 NC GR5 ZP	6
13	51809	WLDMT-SHIELD ANITWRAP (NARROW)	3

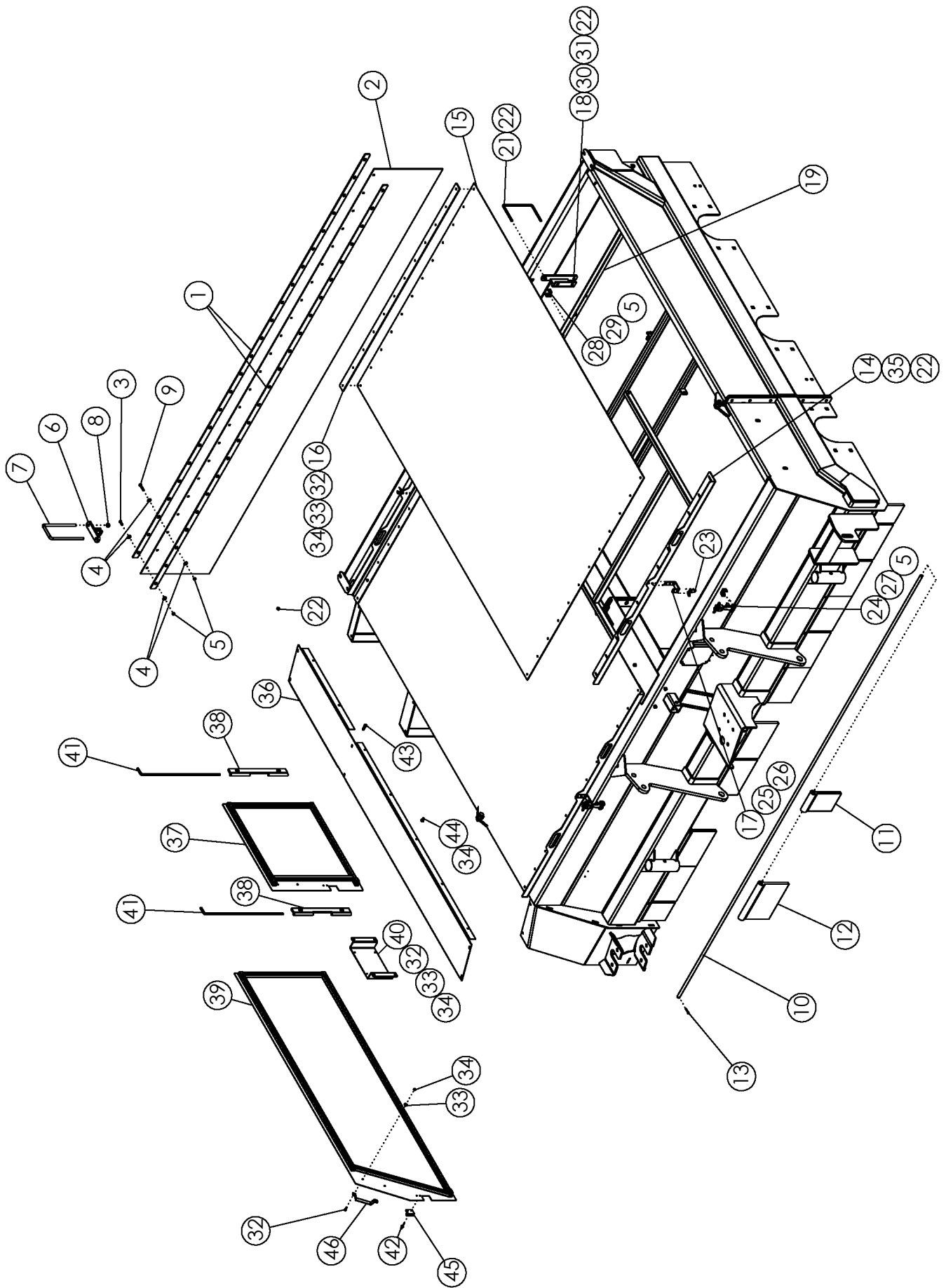

DOORS AND SHIELDS

ITEM	PART NO.	DESCRIPTION	QTY
1	63446	BAR-REAR FLAP 0622, 1222	2
2	52357	FLAP-REAR (6R22, 12R22)	1
3	1011598	BOLT-HEX: .31 X 1.00 NC GR5 ZP	1
4	1011583	WASHER-FLAT: .31 ZP	4
5	1030700	NUT-TOPLOCK: .31 NC GR5 ZP	27
6	63448	WLDMT-REAR FLAP MOUNT	1
7	63458	U-BOLT: .50 X 9.25 X 4.00 X 9.25 ZP	4
8	1027461	NUT-TOPLOCK: .50 NC GR5 ZP	8
9	1013424	BOLT-HEX .31 X 1.75 NC	1
10	305028	SHAFT-RETAINING SHIELD 6R	1
11	64693	FLAP-RUBBER HALF	3
12	64648	FLAP-RUBBER	10
13	1012375	PIN-COTTER .19 X 1.50 NP	1
14	62499	WLDMT-DOOR 6R	4
15	62504	TARP 6R STD	2
16	59815	BRACKET-BOLTING 6R & 12R	2
17	68320	SHEET-TARP BRACKET	2
18	69111	WLDMT-DOOR SUPPORT	2
19	305034	PLATE-DOOR CROSS 6R LH	1
20	305035	PLATE-DOOR CROSS 6R RH	1
21	64244	U-BOLT: .375 X 5.125 X 8.063 X 5.125	2
22	1016999	NUT-TOPLOCK: .38 NC GR5 ZP	4
23	52239	HOOD BRACKET-LARGE	4
24	52238	RUBBER HOOK LARGE	2
25	1013462	SCREW	3
26	1026591	NUT-K-LOCK: .19 NC GR2 ZP	3
27	1011285	BOLT-HEX: .31 X 2.00 NC	4
28	52237	ANCHOR BRACKET-LARGE ZP	2
29	1011597	BOLT-HEX: .31 X .75 NC GR5 ZP	48
30	59488	BOLT-CRG: .38 X 1.00 NC GR5 ZP	2
31	1011828	WASHER-FLAT .38 ZP	2
32	1011595	BOLT-HEX: .25 X .75 NC GR5 ZP	2
33	1020416	WASHER-FLAT: .25 ZP	65
34	1030946	NUT-TOPLOCK: .25 NC GR5 ZP	67
35	1011725	BOLT-HEX: .38 X 2.00 NC	2
36	68201	PANEL-TOP SHIELD	1
37	68386	WLDMT-REAR SIDE DOOR DEF	1
38	72680	WLDMT-DOOR HINGE	2
39	68387	WDLMT-FRONTSIDE DOR DEF	1

CONTINUED

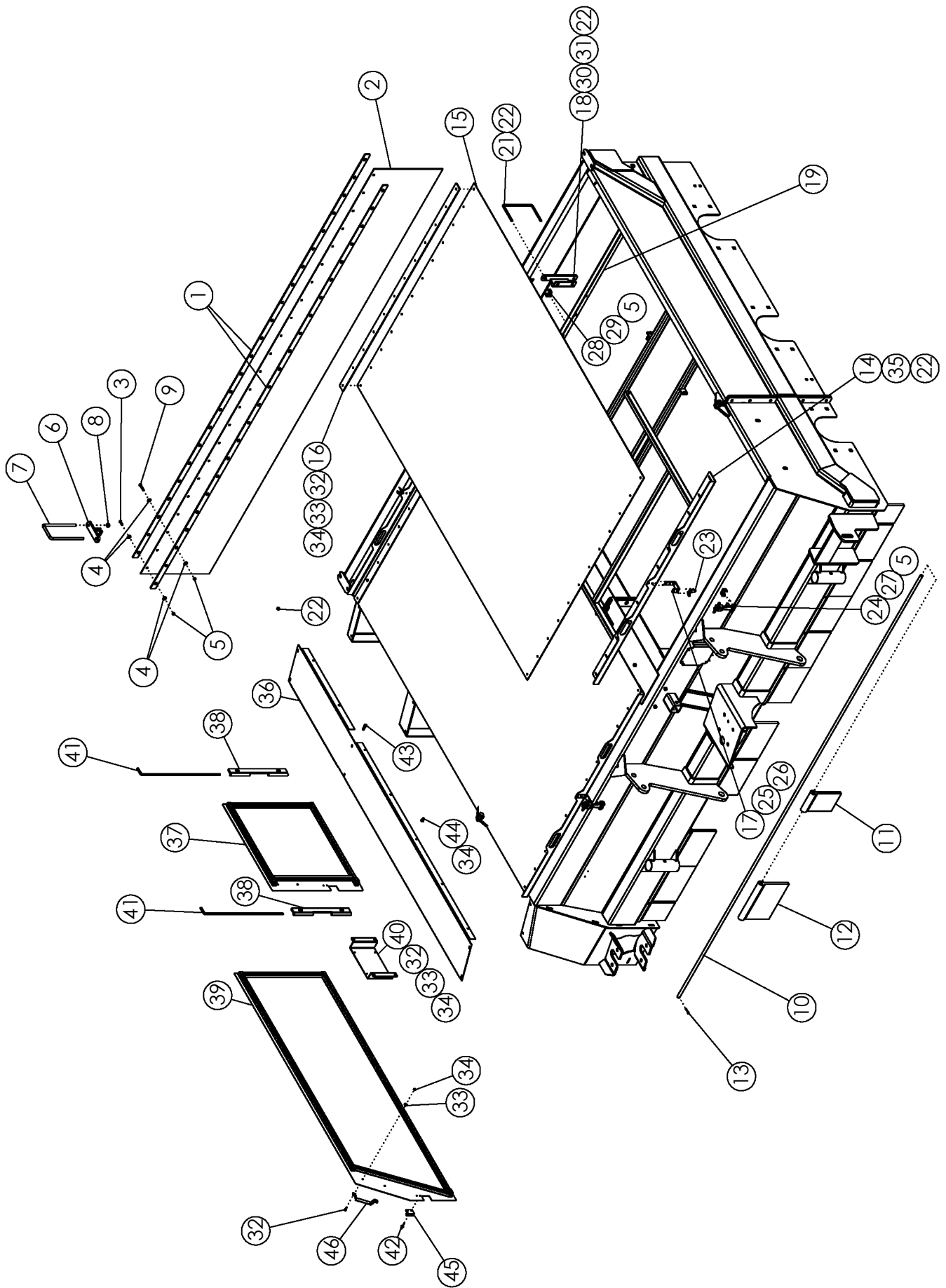

DOORS AND SHIELDS (CONTINUED)

ITEM	PART NO.	DESCRIPTION	QTY
40	68324	PLATE-DEF MANUAL CASE	1
41	51303	DOOR HINGE ROD ZP	2
42	1011974	RIVET-POP .19 X .531 ZP	4
43	1011601	BOLT-HEX: .38 X 1.25 NC GR5 ZP	4
44	65702	BOLT-CRG: .31 X .75 NC GR5 ZP	7
45	69140	WLDMT-DOOR LATCH ZP	2
46	68715	HANDLE-GRAB DOOR	1
47	64635	CASE-MANUAL STORAGE (NOT SHOWN)	1

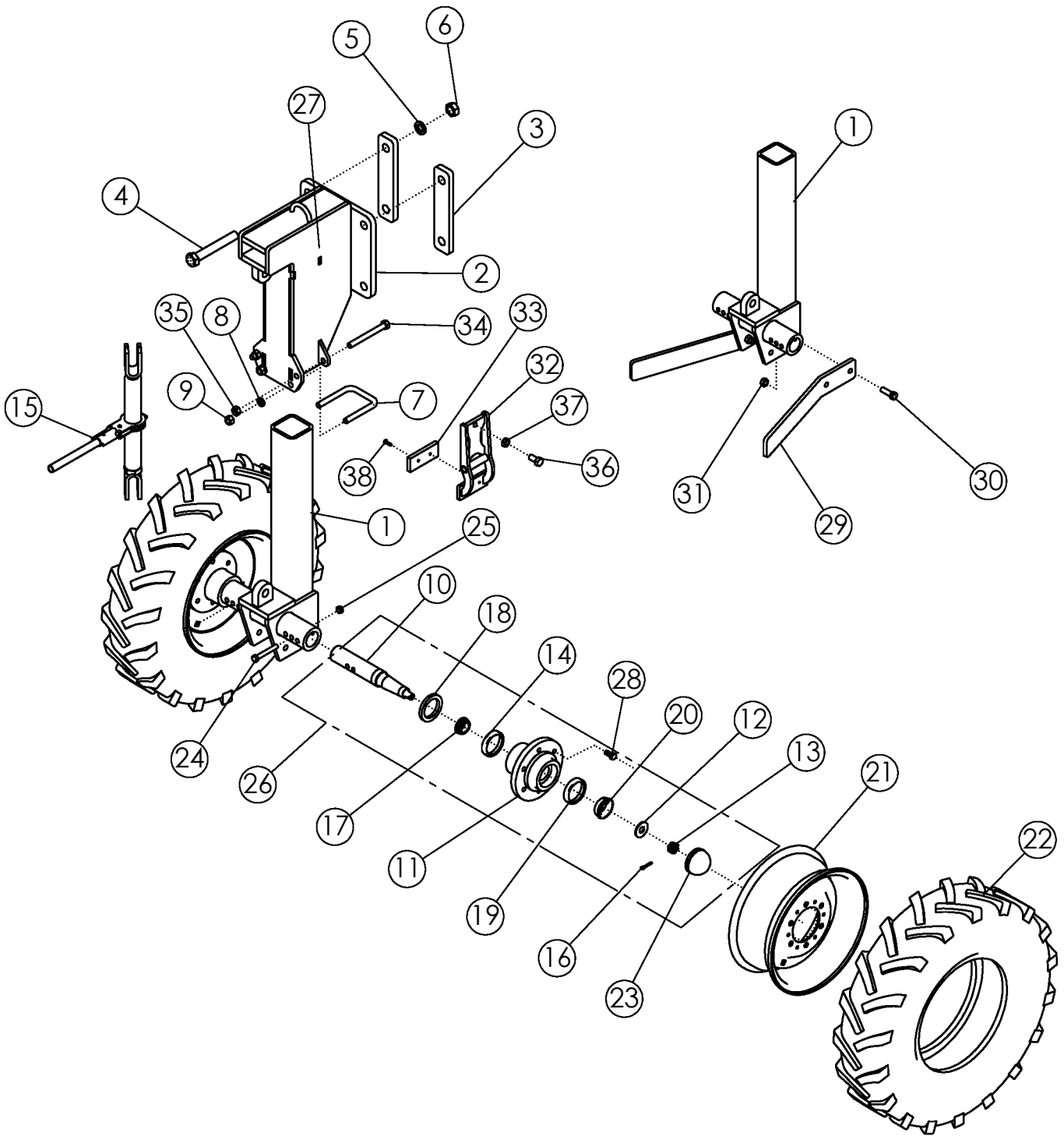

STANDARD REAR STRUTS - 7.60 X 15 TIRES

ITEM	PART NO.	DESCRIPTION	QTY
1	58281	WLDMT-SPINDLE HOUSING	1
	64402	WLDMT-SPINDLE HOUSING- 6" OFFSET RH	1
	64406	WLDMT-SPINDLE HOUSING- 6" OFFSET LH	1
2	63559	WLDMT-STD STRUT UPPER	1
3	58408	BAR - BOLTING	2
4	1018839	BOLT-HEX: 1.00 X 7.00 NC GR8 ZP	4
5	1013539	WASHER-LOCK: 1.00 ZP	4
6	1012664	NUT-HEX: 1.00 NC GR2 ZP	4
7	60547	U-BOLT: .63 X 5.25 X 4.00 X 5.25	1
8	1011813	WASHER-LOCK: .63 ZP	2
9	1011578	NUT-HEX: .63 NC GR2 ZP	2
10	52138*	SPINDLE	2
11	52247*	HUB-WHEEL 6-BOLT	2
12	1012377*	WASHER-SPINDLE: .81 X 2.00 NP	2
13	1012376*	NUT-SLOTTED: .75 NF GR5 NP	2
14	52243*	CUP-BEARING INNER	2
15	52407	RATCHET JACK-PAINTED	1
16	35128	PIN-COTTER: .19 X 1.50 NP	2
17	52245*	CONE-BEARING INNER	2
18	52242*	SEAL	2
19	52244*	CUP-BEARING OUTER	2
20	52246*	CONE-BEARING OUTER	2
21	52411	WHEEL 6.00-15 6 BOLT	2
22	52410	TIRE 7.60-15 I-3 6 PLY	2
	68974	TUBE-REPAIR 7.60-15 (NOT SHOWN)	AR
23	52241*	CAP-HUB	2
24	1011612	BOLT-HEX: .50 X 3.50 NC GR5 ZP	2
25	1027461	NUT-TOPLOCK: .50 NC GR5 ZP	2
26	52116	ASSY HUB & SPINDLE	2
27	52248	DECAL-CAUTION	1
28	1013426*	BOLT-LUG: .50 X 1.00 NF GR5 ZP	12
29	305642	PLATE-SCRAPER 7.6-15 DEF	2
30	1011623	BOLT-HEX: .63 X 2.00 NC GR5 ZP	4
31	1016595	NUT-TOPLOCK: .63 NC GR5 ZP	4
32	69956	WLDMT- DEF STRUT CLAMP	2
33	69971	PLASTIC-STRUT CLAMP	2
34	1013068	BOLT-HEX: .63 X 6.00 NC GR5 ZP	2
35	1016595	NUT-TOPLOCK: .63 NC GR5 ZP	2
36	1030703	BOLT-HEX: .63 X 1.25 NF GR5 ZP	2
37	66336	NUT-JAM: .63 NF GR2 ZP	2
38	69987	SCREW-MACH: FH-TORX .25-20 X 1.00	4

* Items are included in Item 26

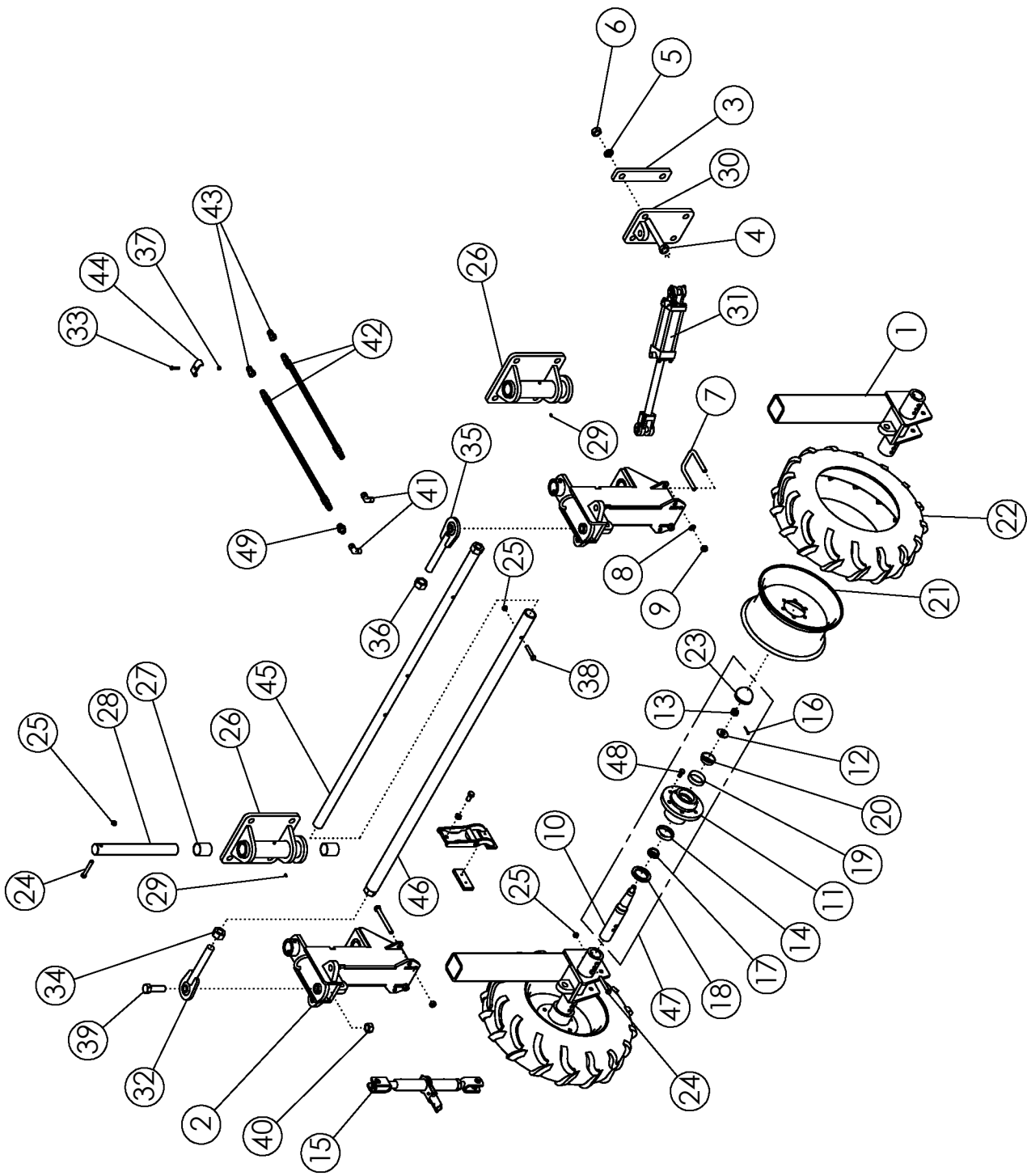

STEERABLE REAR STRUT - 7.6 X 15 TIRES

ITEM	PART NO.	DESCRIPTION	QTY
1	58281	WLDMT-SPINDLE HOUSING	2
2	63558	WLDMT-STEERABLE STRUT UPPER	2
3	58408	BAR - BOLTING	6
4	1018839	BOLT-HEX: 1.00 x 7.00 NC GR8 ZP	12
5	1013539	WASHER-LOCK: 1.00 ZP	12
6	1012664	NUT-HEX: 1.00 NC GR2 ZP	12
7	60547	U-BOLT: .63 X 5.25 X 4.00 X 5.25	2
8	1011813	WASHER-LOCK: .63 ZP	4
9	1011578	NUT-HEX: .63 NC GR2 ZP	4
10	52138*	SPINDLE	4
11	52247*	HUB-WHEEL 6 BOLT	4
12	1012377*	WASHER-SPINDLE: .81 X 2.00 NP	4
13	1012376*	NUT-SLOTTED: .75 NF GR5 NP	4
14	52243*	CUP-BEARING INNER	4
15	52407	RATCHET JACK-PAINTED	2
16	1012375*	PIN-COTTER: .19 X 1.50 NP	4
17	52245*	CONE-BEARING INNER	4
18	52242*	SEAL	4
19	52244*	CUP-BEARING OUTER	4
20	52246*	CONE-BEARIGN OUTER	4
21	52411	WHEEL 6.00-15 6 BOLT	4
22	52410	TIRE 7.60-15 I-3 6 PLY	4
	68974	TUBE-REPAIR 7.60-15 (NOT SHOWN)	AR
23	52241*	CAP-HUB	4
24	1011612	BOLT-HEX: .50 X 3.50 GR5 ZP	6
25	1027461	NUT-TOPLOCK: .50 NC GR5 ZP	7
26	58283	WLDMT-PIVOT MOUNT	2
27	59204	BUSHING - BORED	4
28	58274	SHAFT	2
29	1011748	ZERK - GREASE	4
30	58410	WLDMT-CYLINDER BRACKET	1
31	62319	CYLINDER HYDRAULIC 2 X 4	1
	69654	SEAL KIT FOR 62319	
32	58203	WLDMT-TIE ROD END LH	1
33	1014124	BOLT-HEX: .31 X 1.50 NC GR5 ZP	2
34	1030729	NUT-HEX: 1.25 NC GR2 LH ZP	1
35	58186	WLDMT-TIE ROD END RH	1
36	1011621	NUT-HEX: 1.25 NC GR2 ZP	1
37	1030700	NUT-HEX: .31 NC GR5 ZP	2
38	1016858	BOLT-HEX: .50 X 2.75 NC GR5 ZP	1
39	1011626	BOLT-HEX: 1.00 X 3.50 NC GR5 ZP	2

CONTINUED

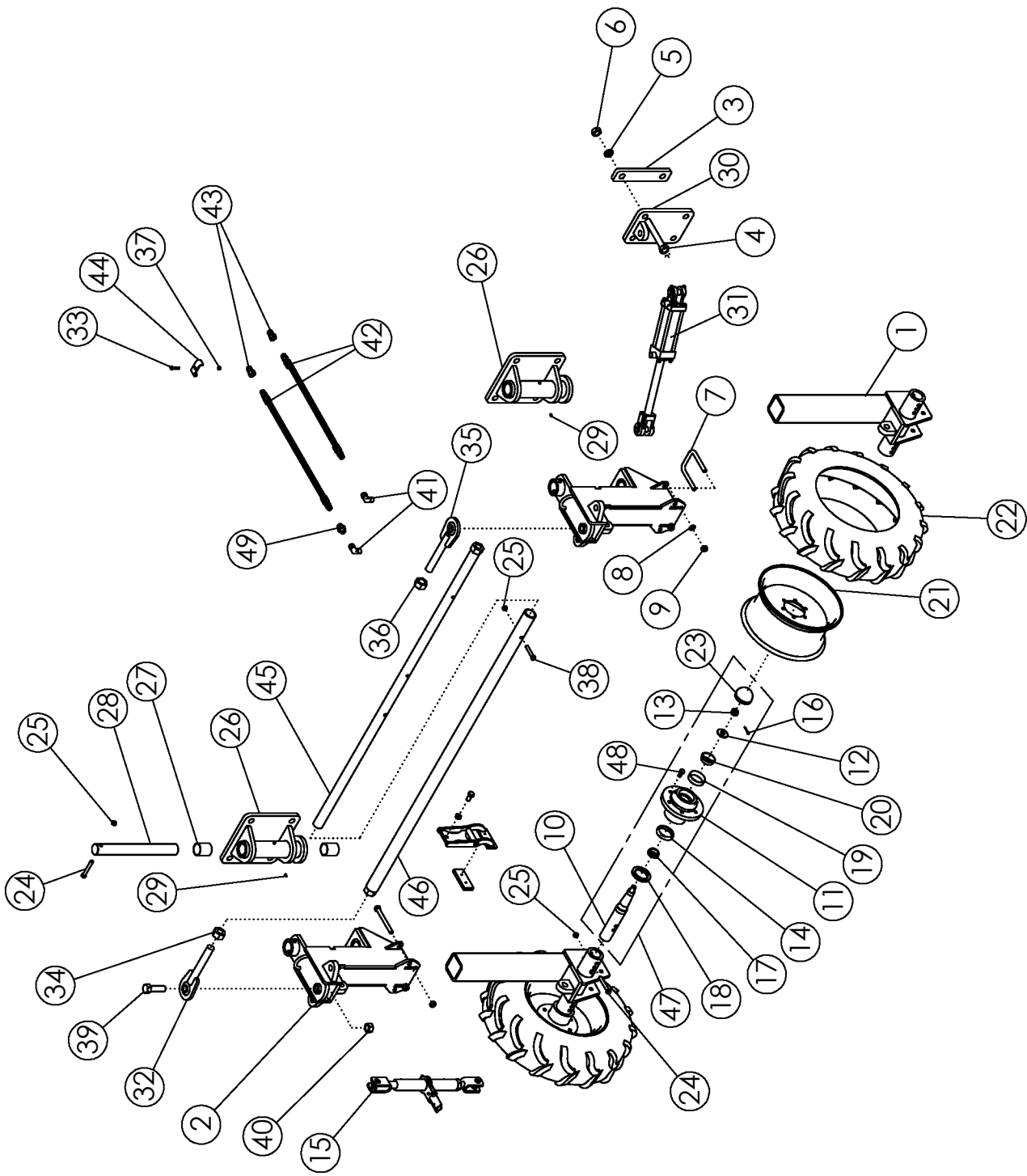

STEERABLE REAR STRUT - 7.6 X 15 TIRES (CONTINUED)

ITEM	PART NO.	DESCRIPTION	QTY
40	1016969	NUT-TOPLOCK: 1.00 NC GR5 ZP	2
41	52421	FTG-ELBOW: 6MB-8FPX 90	2
42	52261	HOSE: .50 X 276 8MP-8MP	2
43	53631	PIONEER TIP 8010-4	2
44	50714	CLAMP 1/2" ZP	2
45	58415	WLDMT-TIE ROD MALE 70"	1
46	58416	WLDMT-TIE ROD FEMALE 70"	1
47	52116	ASSY-HUB & SPINDLE	4
48	1013426*	BOLT-LUG: .50 X 1.00 GR5 ZP	24
49	64737	FTG-RESTRICTOR 8MP-8FPX .063	1

* Items are included in Item 47

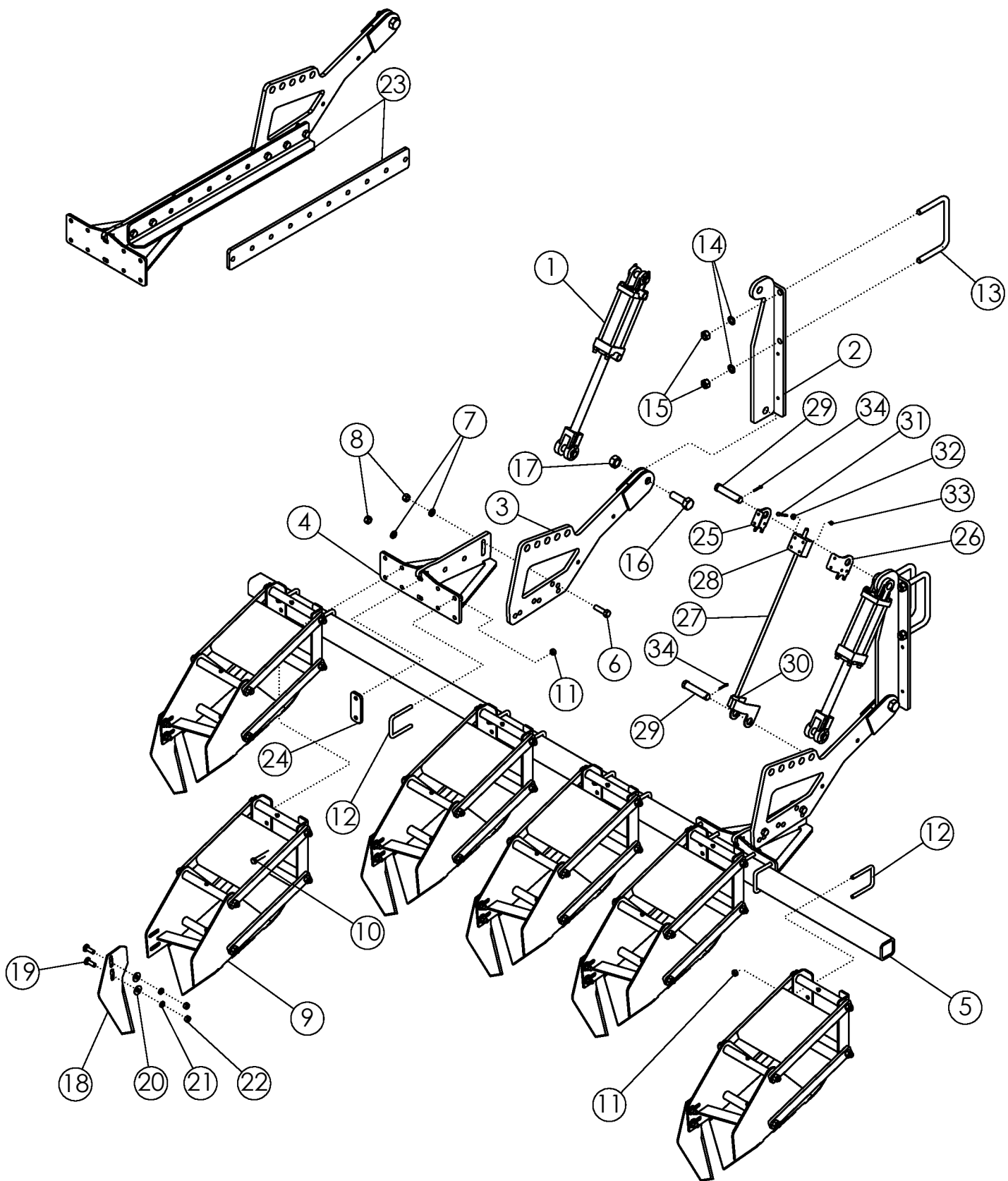

SCALPER BAR ASSEMBLY

ITEM	PART NO.	DESCRIPTION	QTY
1	58890	CYLINDER HYDRAULIC 3 X 8	2
	301314	SEAL KIT FOR 58890 UNIVERSAL	
2	68239	WLDMT - MOUNT	2
3	69126	WLDMT-SCALPER ARM MNT	2
4	69127	WLDMT-BAR MNT BRACKET	2
5	51865	SCALPER BAR	1
6	1017526	BOLT-HEX .63 X 2.25 NC GR5 ZP	4
7	1011813	WASHER-LOCK: .63 ZP	4
8	1011578	NUT-HEX: .63 NC GR2 ZP	4
9	63462	ASSY-SCALPER BASKET	6
10	1013682	BOLT-HEX: .50 x 4.50 NC GR5 ZP	8
11	1027461	NUT-TOPLOCK: .50 NC GR5 ZP	36
12	69954	U-BOLT: .50 X 4.50 X 3 X 4.50	14
13	56263	U-BOLT: .75 X 5.5 X 8 X 5.5	4
14	1012061	WASHER-LOCK: .75 ZP	8
15	1011620	NUT-HEX: .75 NC GR2 ZP	8
16	1018007	BOLT-HEX: 1.0 X 3.00 NC GR5 ZP	2
17	1016969	NUT-TOPLOCK: 1.00 NC GR5 ZP	2
18	51782	SCALPER KNIFE-HEAT TREAT	6
19	1011660	BOLT-CRG: .50 X 1.50 NC GR5 ZP	12
20	1014443	WASHER-FLAT: .50 ZP	12
21	1011581	WASHER-LOCK: .50 ZP	12
22	1011577	NUT-HEX: .50 NC ZP	12
23	305183*	PLATE-SCALPER EXTENSION	3
	306101	PLATE-SCALPER EXT FLAT	
24	51551	BAR-BASKET MOUNTING	2
25	306962	PLATE-DEPTH GAUGE BRACKET RH	1
26	306963	PLATE-DEPTH GAUGE BRACKET LH	1
27	63999	WLDMT-BOTTOM BRACKET ZP	1
28	63383	POLY GUIDE BLOCK	1
29	63406	PIN-CLEVIS: 1.00 X 4.00 ZP	2
30	63359	COLLAR-SET: 9/16 ZP	1
31	1016211	BOLT-HEX: .25 X 2.00 NC GR5 ZP	4
32	1020416	WASHER-FLAT: .25 ZP	4
33	1030946	NUT-TOPLOCK: .25 NC GR5 ZP	4
34	1012375	PIN-COTTER: .19 X 1.50 ZP	2

*USED WITH LARGER TIRE OPTION

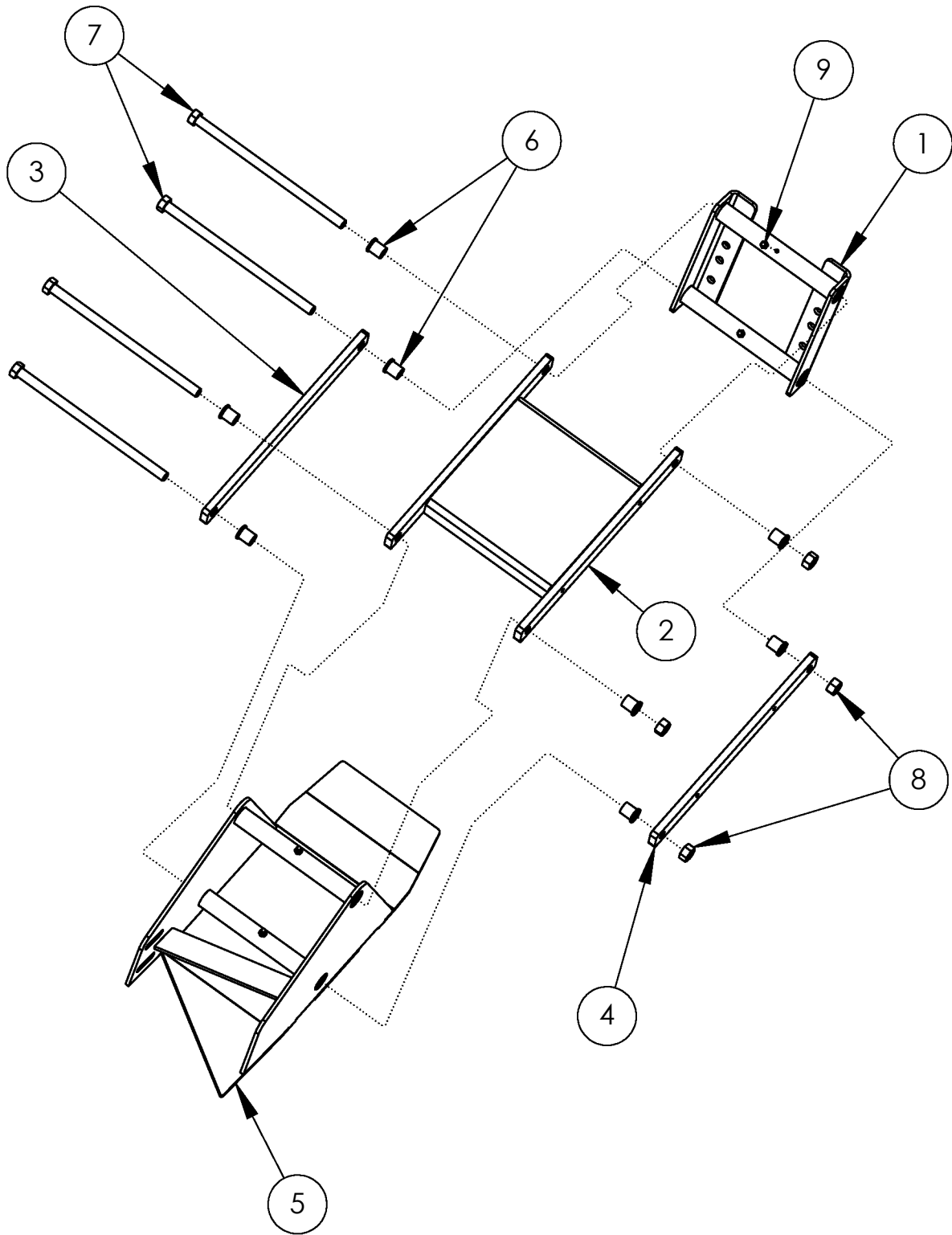

SCALPER BASKET #63462

ITEM	PART NO.	DESCRIPTION	QTY
1	63551*	WLDMT-BASKET MOUNT	1
2	306849*	WLDMT-UPPER LINK	1
3	63555*	BAR-PARALLEL LINK	1
4	306848*	BAR-PARALLEL LINK AHC THREADED PC	1
5	63550	WLDMT-BASKET FRAME	1
	306948*	WLDMT-BASKET FRAME V2	
6	306080*	BUSHING-FLANGE: .628 X 8.16 X 1.4375L	8
7	306752*	BOLT-HEX: .63 X 11.813 N GR5 ZP	4
8	59316*	NUT-CENTERLOCK: .625 NC GR5 ZP	4
9	1011748*	ZERK-GREASE .25 UNF STRAIGHT	4

* Used in 307161 ASSY-SCALPER BASKET SHORT

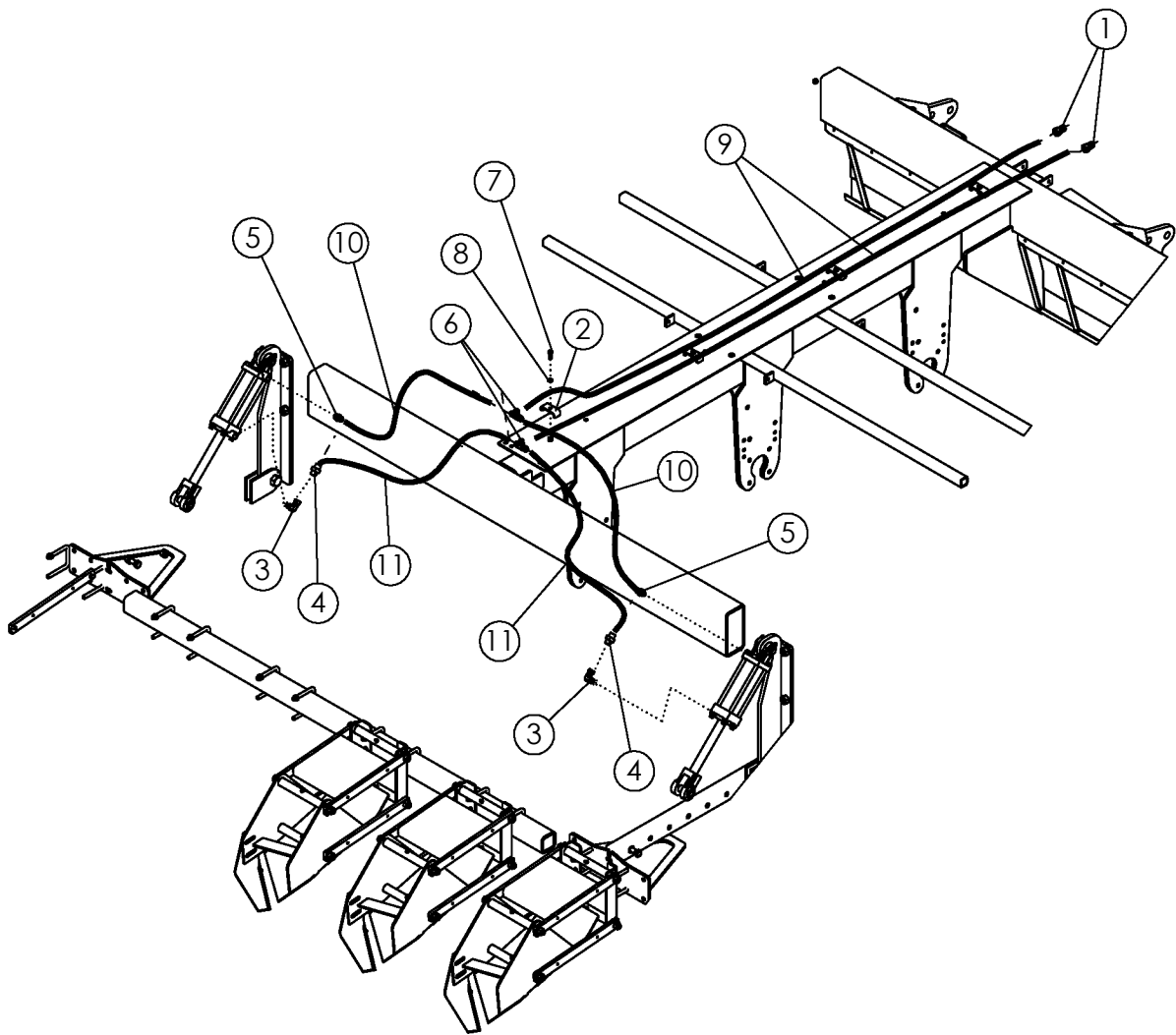

SCALPER HYDRAULICS

ITEM	PART NO.	DESCRIPTION	QTY
1	36290	PIONEER TIP 8010-15P (#8 ORB)	2
2	50714	CLAMP .50 ZP	4
3	58560	FTG-ELBOW: 8MB-8MJ-90	2
4	1019844	FITTING-RESTRICTOR (8FJ-8MJ .090)	2
5	56226	FTG-ADAPTER: 8MB-8MJ	2
6	57667	FTG-TEE: 8MJ-8MJ-8MJ	2
7	1011600	BOLT-HEX: .38 X 1.00 NC GR5 ZP	4
8	1011586	WASHER-LOCK: .38 ZP	4
9	305428	HOSE: .50 X 218 8MB-8FJX	2
10	72474	HOSE: .38 X 88 8FJX-8FJX	2
11	72473	HOSE: .38 X 95 8FJX-8FJX	2

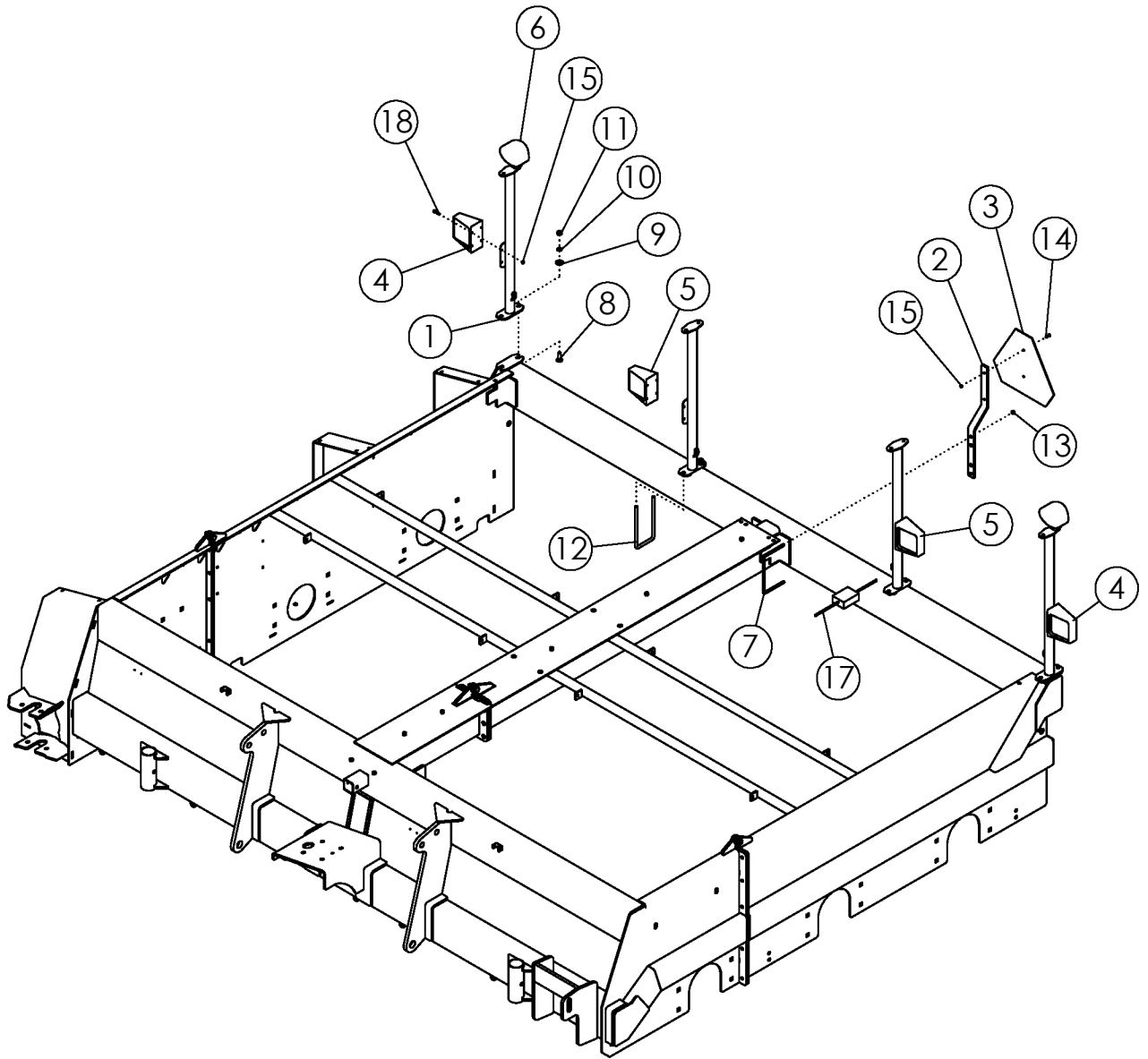

LIGHT KIT

ITEM	PART NO.	DESCRIPTION	QTY
1	305219	WLDMT-LIGHT MOUNT	4
2	64246	MOUNT-SMV SIGN	1
3	65329	SIGN-SMV ASAE	1
4	305217	LIGHT-YELLOW LAMP SAE	2
5	305218	LIGHT-RED LAMP SAE	2
6	301294	LIGHT-GROTE T26 NEAR FLOOD	2
7	64244	U-BOLT: .375 X 5.125 X 8.063 X 5.125	1
8	1011660	BOLT-CRG: .50 X 1.50 NC GR5 ZP	4
9	1014443	WASHER-FLAT: .50 ZP	8
10	1011581	WASHER-LOCK: .50 ZP	8
11	1011577	NUT-HEX: .50 NC ZP	8
12	63458	U-BOLT: .50 X 9.25 X 4.00 X 9.25 ZP	2
13	1016999	NUT-TOPLOCK: .38 NC GR5 ZP	2
14	1011595	BOLT-HEX: .25 X .75 NC GR5 ZP	2
15	1030946	NUT-TOPLOCK: .25 NC GR5 ZP	18
16	1013122	TIE-NYLON CABLE 50# X 15.50" (NOT SHOWN)	12
17	305216	MODULE-FLASHER HARNESS	1
18	1013940	BOLT-HEX: .25 X 1.25 NC GR5	16
19	306761	HARNESS-DEF LIGHT MAIN (NOT SHOWN)	1
20	305292	HARNESS-DEF WORK LIGHT (NOT SHOWN)	1
21	305291	HARNESS-DEF HAZARD (NOT SHOWN)	1

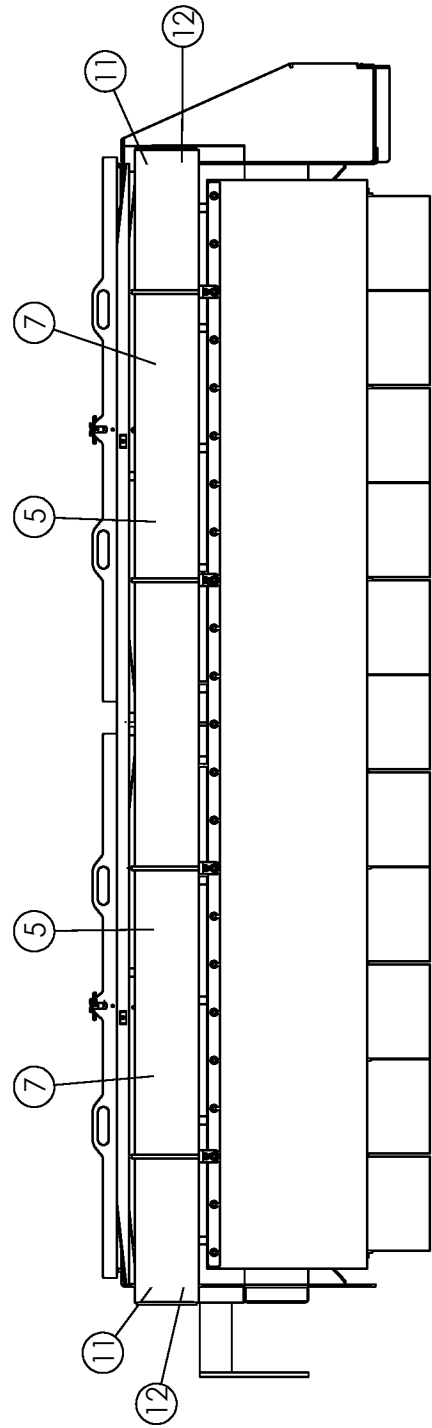
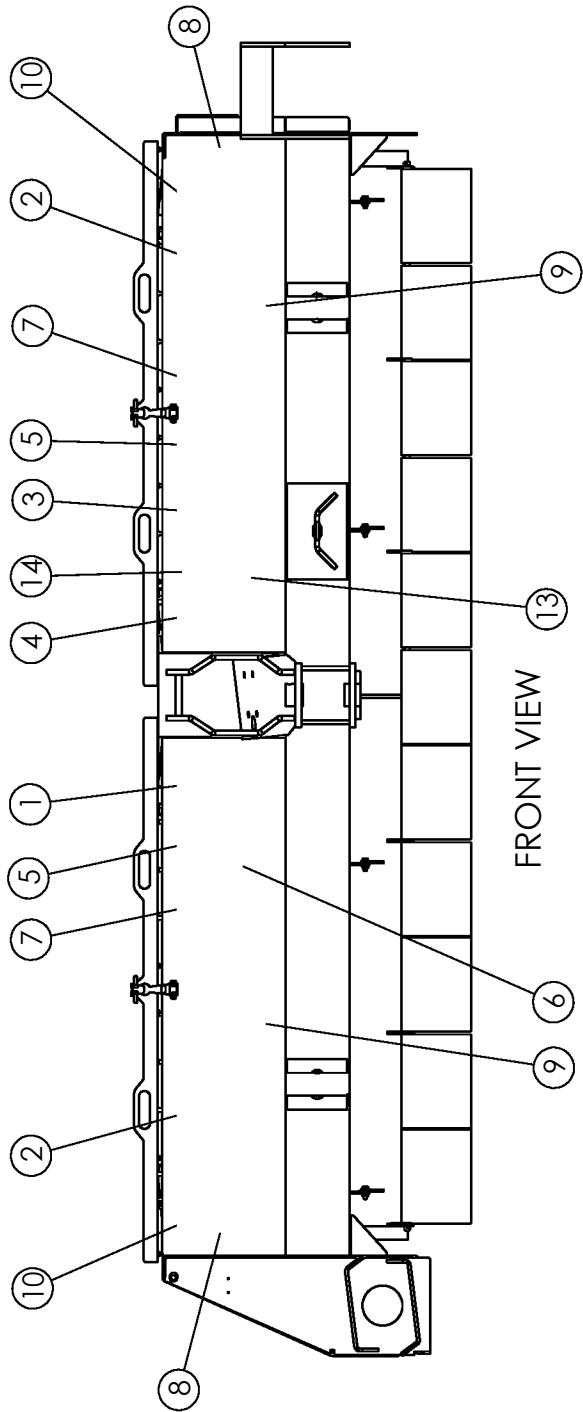

DECALS

ITEM	PART NO.	DESCRIPTION	QTY
1	9971013	DECAL-GUARD MISSING	1
2	9971015	DECAL-FALL OFF HAZARD	2
3	303263	DECAL-DANGER MOVING PARTS	1
4	997859	DECAL-ENGINE OFF	1
5	303267	DECAL-DANGER FLAILS	4
6	303268	DECAL DANGER ROTATING	1
7	307165	DECAL-CAUTION DOORS	4
8	303265	DECAL-DANGER UNDER MACHINE	2
9	63465	DECAL-AMITY LOGO SMALL	2
10	65331	DECAL-RETROFLECTIVE-YELLOW	2
11	65330	DECAL-RETROFLECTIVE-RED	2
12	65332	DECAL-RED ORANGE FLUORESCENT	2
13	997867	DECAL-FLUID UNDER PRESSURE	1
14	303769	DECAL-US PATENT QR CODE	1

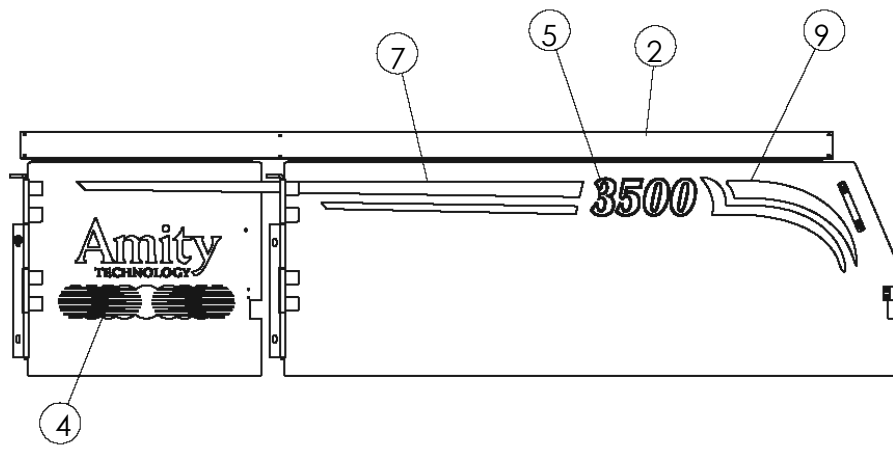

RIGHT SIDE DOOR

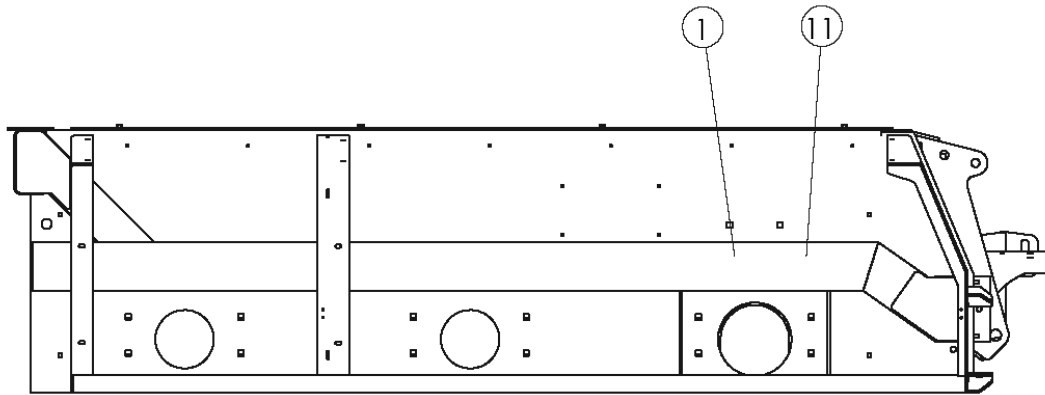

RIGHT SIDE UNDERNEATH DOOR

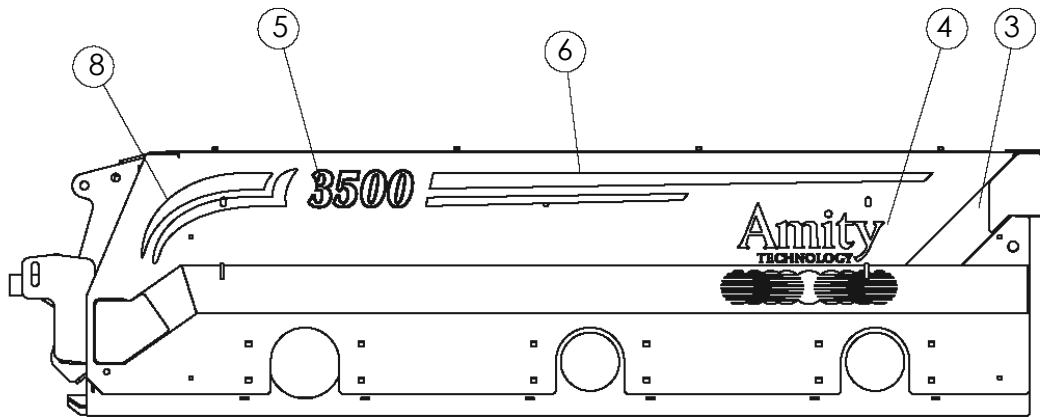

LEFT SIDE

10

DEF-00 Series Hose Color Chart	
Black	Hitch
Blue	Row Finder Constant or Centering Steering
Yellow	Row Finder Override or Steering
Green	Scalper and/or Row Finder Lift
Orange	Strut Lift/AHC Constant
Red	Door Lift

PN: 302231

DECALS

ITEM	PART NO.	DESCRIPTION	QTY
1	9971013	DECAL-GUARD MISSING	1
2	303263	DECAL-DANGER MOVING PARTS	1
3	65331	DECAL-YELLOW RETROFLECTIVE	2
4	69399	DECAL-AMITY LOGO 12X24	2
5	69400	DECAL-3300 6X12 (6R22,4R30)	2
	69402	DECAL-3500 6X12 (8R22, 6R30)	
	69403	DECAL-3600 6X12 (9R)	
	69404	DECAL-3700 6X12 (12R22, 8R30)	
	305692	DECAL-3750 6X12	
6	69406	DECAL-LH STRIPE	1
7	69408	DECAL-RH STRIPE	1
8	69405	DECAL-LH CURVE	1
9	69407	DECAL-RH CURVE	1
10	302231	DECAL - HYD LABEL: 00 SERIES HOSE COLORS	1
11	303804	DECAL -PROUDLY MADE AT AMITY	1

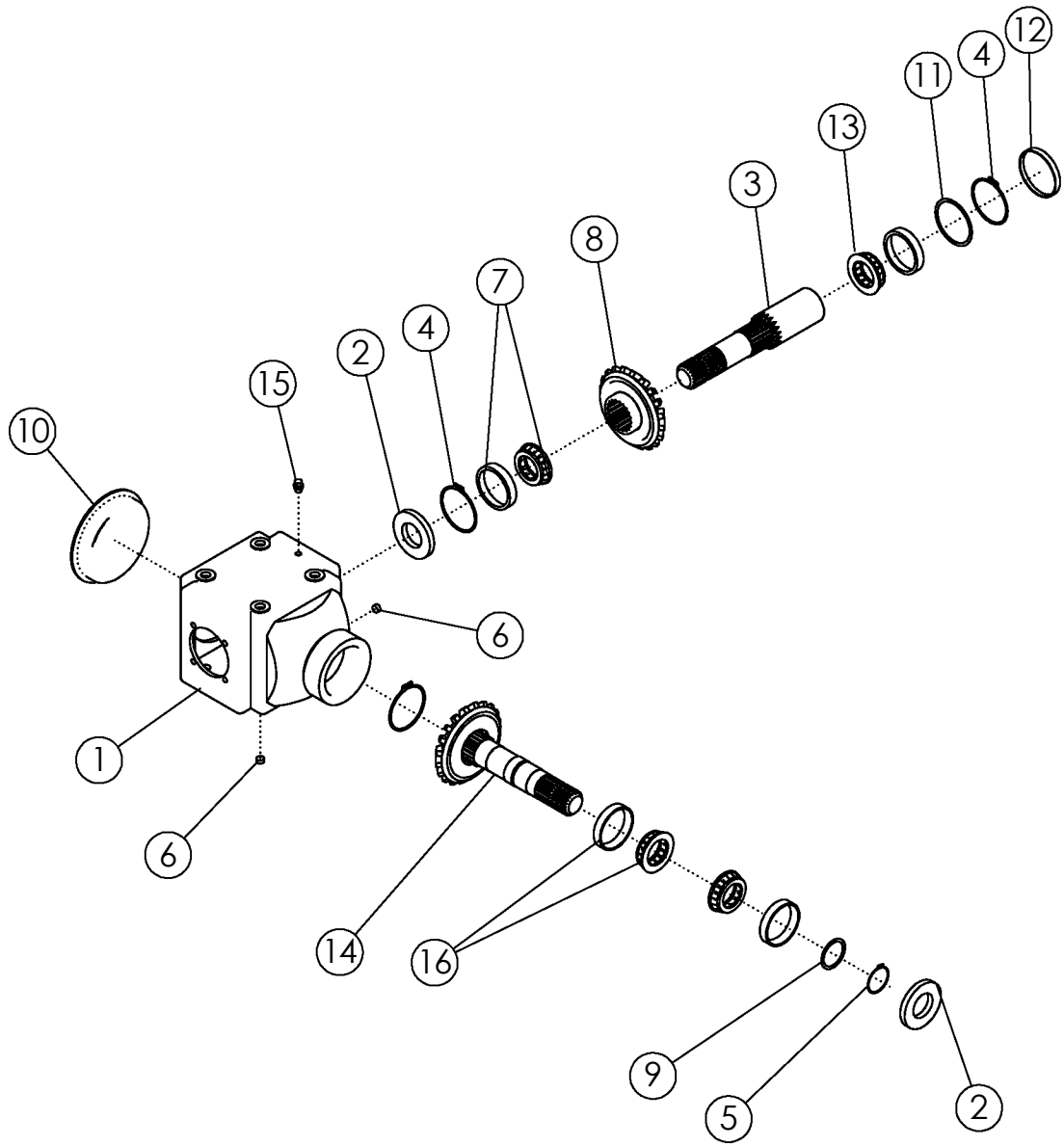

GEARBOX - L TYPE

ITEM	PART NO.	DESCRIPTION	QTY
--	52391	GEARBOX 1.57:1 COMPLETE	
--	52392	GEARBOX 1:1 COMPLETE	
1	59965	HOUSING GEARBOX	1
2	54214	OIL SEAL	2
3	54207	SHAFT	1
4	54210	SNAP RING	2
5	54209	SNAP RING	1
6	54215	OIL PLUG	3
7	54212	BEARING-TAPERED ROLLER	1
8	54227	GEAR CROWN (1.57:1 GEARBOX)	1
9	54218	SPACER RING -- .012 PER M THICKNESS	AR
	54219	SPACER RING -- .016 PER M THICKNESS	
	54220	SPACER RING -- .024 PER M THICKNESS	
	54221	SPACER RING -- .032 PER M THICKNESS	
	54222	SPACER RING -- .040 PER M THICKNESS	
	64421	KIT-SPACER RING (INCLUDES SPACERS IN ITEM 9)	
10	54208	PLATE-COVER	1
11	54223	SPACER RING -- .012 PER M THICKNESS	AR
	54224	SPACER RING -- .016 PER M THICKNESS	
	54225	SPACER RING -- .024 PER M THICKNESS	
	54226	SPACER RING -- .032 PER M THICKNESS	
	59958	SPACER RING -- 1.00 PER M THICKNESS	
	64422	KIT-SPACER RING (INCLUDES SPACERS IN ITEM 11)	
12	54217	CLOSING CAP	1
13	54211	BEARING BALL	2
14	54228	GEAR-PINION (1.57:1 GEARBOX)	1
15	54204	OIL BREATHER VENT PLUG	1
16	54213	BEARING-TAPERED ROLLER	2
	59962	BEVEL GEAR SET (INCLUDES ITEMS 8 AND 14)	

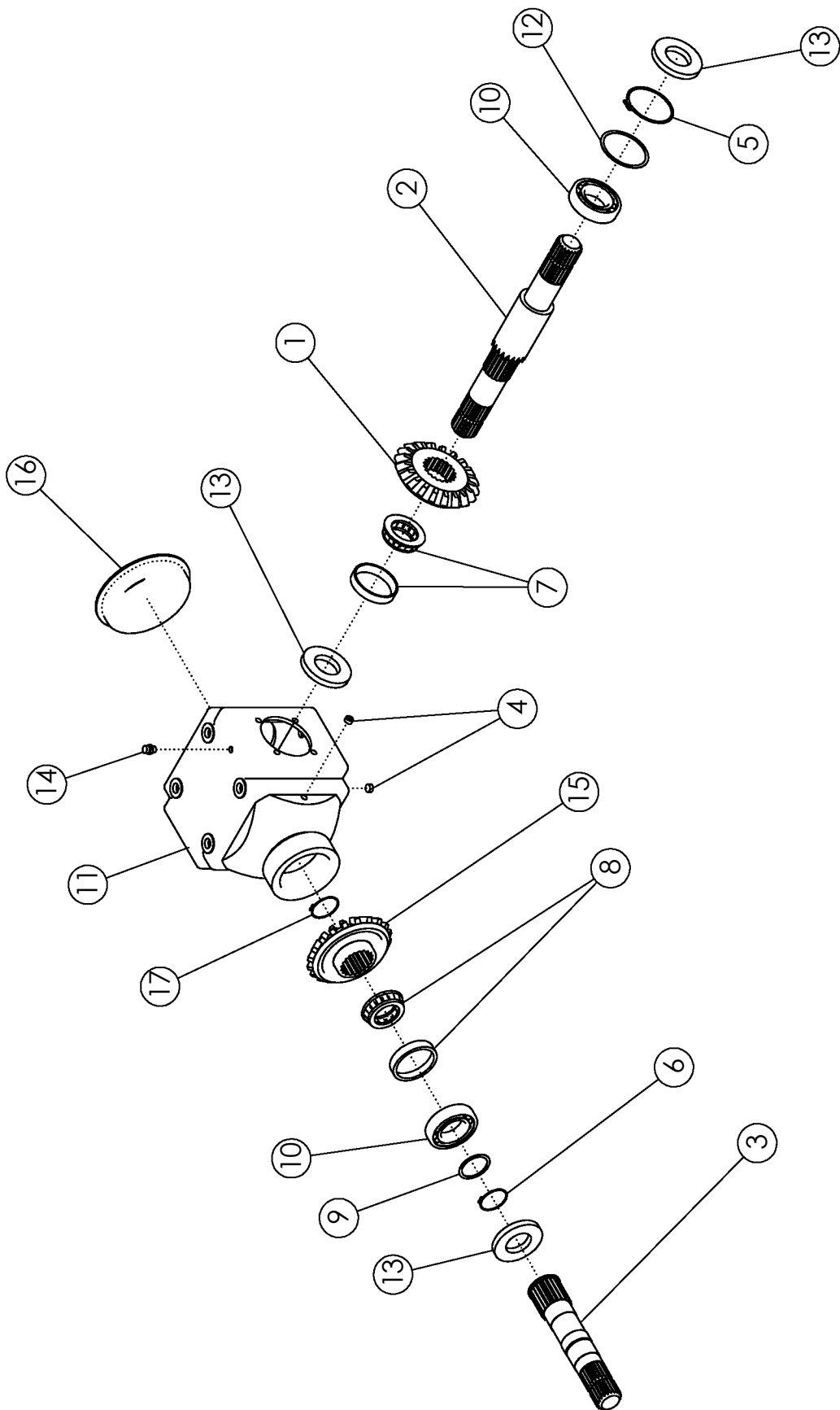

GEARBOX - T TYPE

ITEM	PART NO.	DESCRIPTION	QTY
--	52379	GEARBOX 1:1.57 COMPLETE With Steel Flails Only	
--	52393	GEARBOX 1.57:1 COMPLETE	
1	59964	GEAR SET	1
2	54230	THRU SHAFT	1
3	54231	OUTPUT SHAFT	1
4	54215	OIL PLUG	3
5	54210	SNAP RING	2
6	54209	SNAP RING	1
7	54212	BEARING TAPERED ROLLER	1
8	54213	BEARING TAPERED ROLLER	1
9	54218	SPACER RING -- .012 PER M THICKNESS	AR
	54219	SPACER RING -- .016 PER M THICKNESS	
	54220	SPACER RING -- .024 PER M THICKNESS	
	54221	SPACER RING -- .032 PER M THICKNESS	
	54222	SPACER RING -- .040 PER M THICKNESS	
	64421	KIT-SPACER RING (INCLUDES SPACERS IN ITEM 9)	
10	54211	BEARING BALL	2
11	59965	HOUSING GEARBOX	1
12	54223	SPACER RING -- .012 PER M THICKNESS	AR
	54224	SPACER RING -- .016 PER M THICKNESS	
	54225	SPACER RING -- .024 PER M THICKNESS	
	54226	SPACER RING -- .032 PER M THICKNESS	
	59958	SPACER RING -- 1.00 PER M THICKNESS	
	64422	KIT-SPACER RING (INCLUDES SPACERS IN ITEM 12)	
13	54214	OIL SEAL	3
14	54204	OIL BREATHER VENT PLUG	1
15	54227	CROWN (1.57:1 GEARBOX 52393)	1
	54229	CROWN (1:1.57 GEARBOX 52379)	
16	54208	PLATE-COVER	1
17	52521	SNAP RING	1
	59964	BEVEL GEAR SET (INCLUDES MATCHED ITEMS 1 AND 15)	

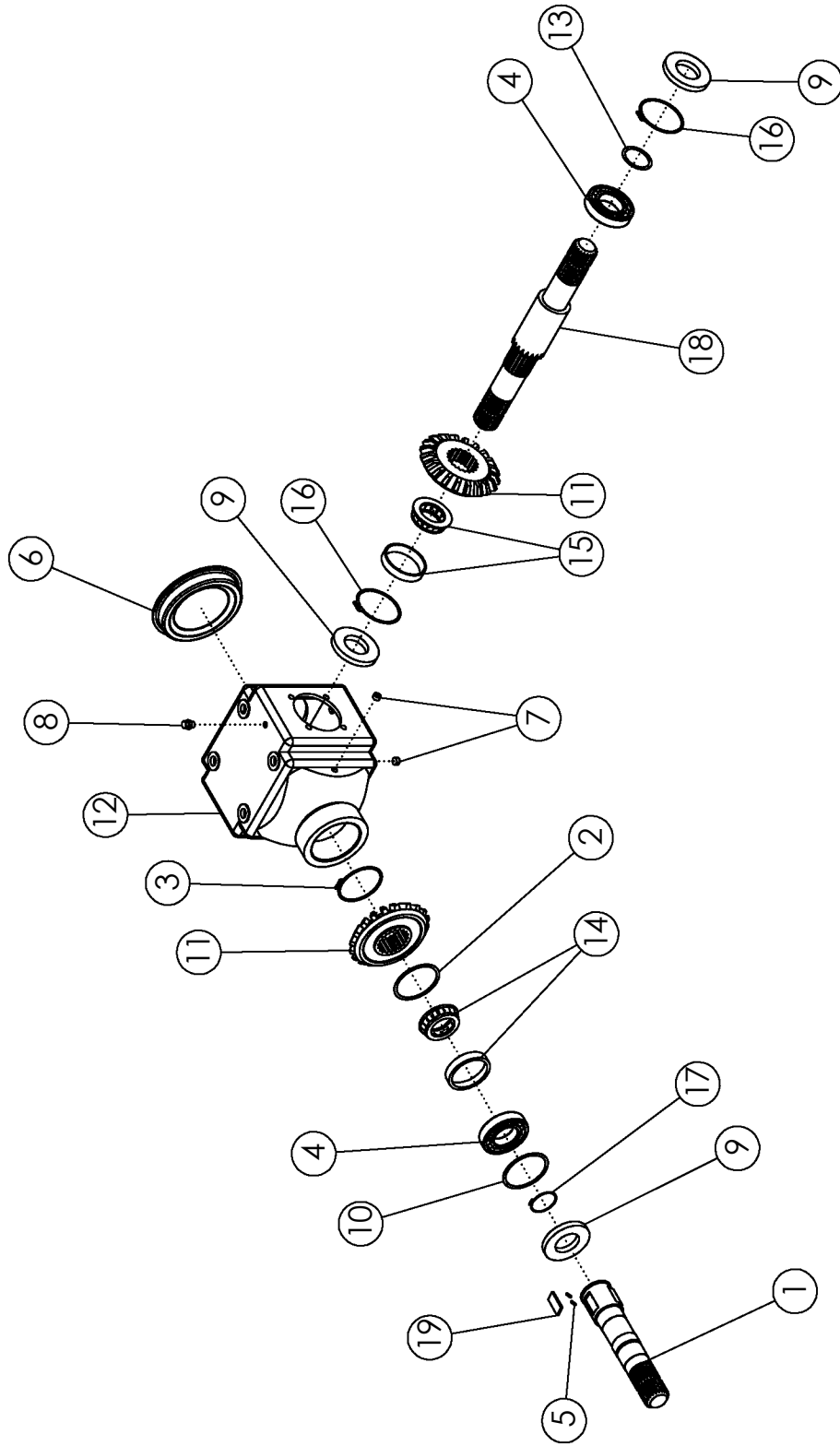

GEARBOX - T TYPE WITH OVERRUN

ITEM	PART NO.	DESCRIPTION	QTY
--	59189	GEARBOX 1:1 2-WAY WITH OVERRUN CLUTCH	1
1	59954	SHAFT-OUTPUT	1
2	59955	SPACER	1
3	59957	SNAP RING-CIRCLIP	1
4	54211	BEARING BALL	2
5	59960	SPRING-GEARBOX SHAFT	6
6	54208	PLATE-COVER	1
7	54215	OIL PLUG	2
8	54204	OIL BREATHER VENT PLUG	1
9	54214	OIL SEAL	3
10	54218	SPACER RING -- .012 PER M THICKNESS	AR
	54219	SPACER RING -- .016 PER M THICKNESS	
	54220	SPACER RING -- .024 PER M THICKNESS	
	54221	SPACER RING -- .032 PER M THICKNESS	
	54222	SPACER RING -- .040 PER M THICKNESS	
	64421	KIT-SPACER RING (INCLUDES SPACERS IN ITEM 10)	
11	59961	BEVELLED GEAR SET (2 MATCHED GEARS)	1
12	59953	HOUSING-GEARBOX	1
13	54223	SPACER RING -- .012 PER M THICKNESS	AR
	54224	SPACER RING -- .016 PER M THICKNESS	
	54225	SPACER RING -- .024 PER M THICKNESS	
	54226	SPACER RING -- .032 PER M THICKNESS	
	59958	SPACER RING -- 1.00 PER M THICKNESS	
	64422	KIT-SPACER RING (INCLUDES SPACERS IN ITEM 13)	
14	54213	BEARING TAPERED ROLLER	1
15	54212	BEARING TAPERED ROLLER	1
16	54210	SNAP RING	2
17	54209	SNAP RING	1
18	54230	THRU SHAFT	1
19	59956	PLATE-GEARBOX SHAFT	3

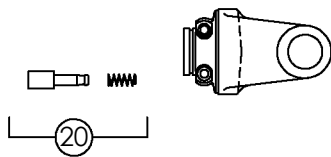
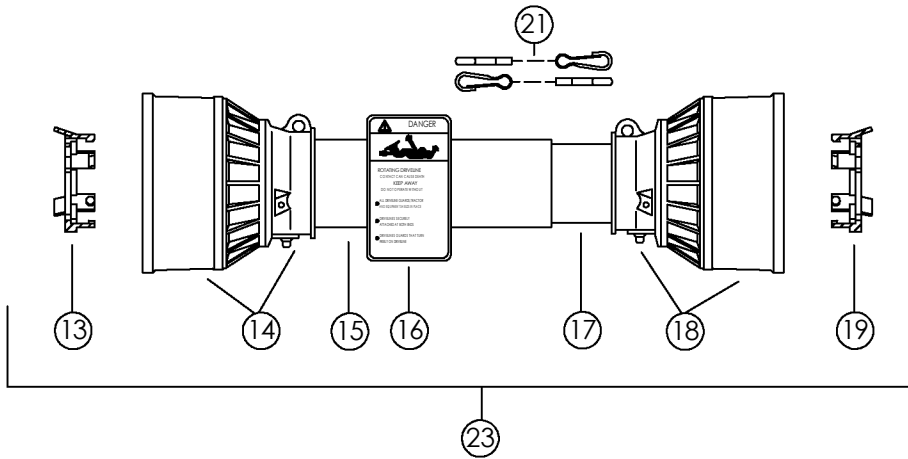
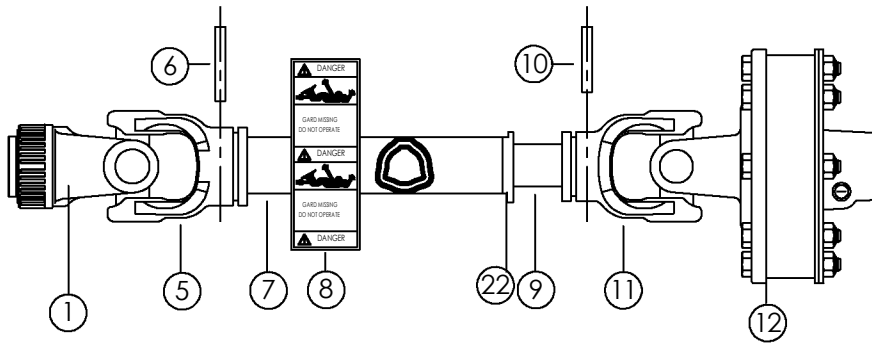
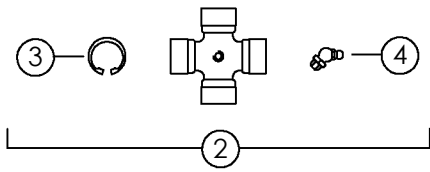

PTO - STANDARD 38MM-8 #69678

ITEM	PART NO.	DESCRIPTION	QTY
1	63676	YOKE-32 X 38 (8 SPLINE) BONDIOLI	1
2	54235	CROSS KIT	2
3	55361	CIRCLIP	8
4	54236	GREASE NIPPLE	2
5	54242	YOKE-OUTER TUBE	1
6	55364	FLEXIBLE PIN	1
7	69867	TUBE OUTER	1
8	63293	DECAL-DRIVELINE	1
9	69868	TUBE INNER	1
10	55367	FLEXIBLE PIN	1
11	54234	YOKE INNER TUBE	1
12	305198	CLUTCH-TORQUE LIMITER	1
13	54238	BRG RING-OUTER SHIELD	1
14	55374	SHIELD CONE-OUTER	1
15	69869	OUTER SHIELD	1
16	63294	DECAL-DRIVELINE	1
17	69870	INNER SHIELD	1
18	55320	CONE SET-INNER SHIELD	1
19	54240	BRG RING-INNER SHIELD	1
20	64430	COMPLETE PUSH BUTTON	1
21	69873	CHAIN	1
22	69874	COLLAR-GREASE	1
23	69875	KIT-SHIELD COMPLETE W/CHAINS	1

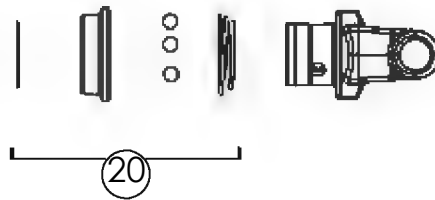
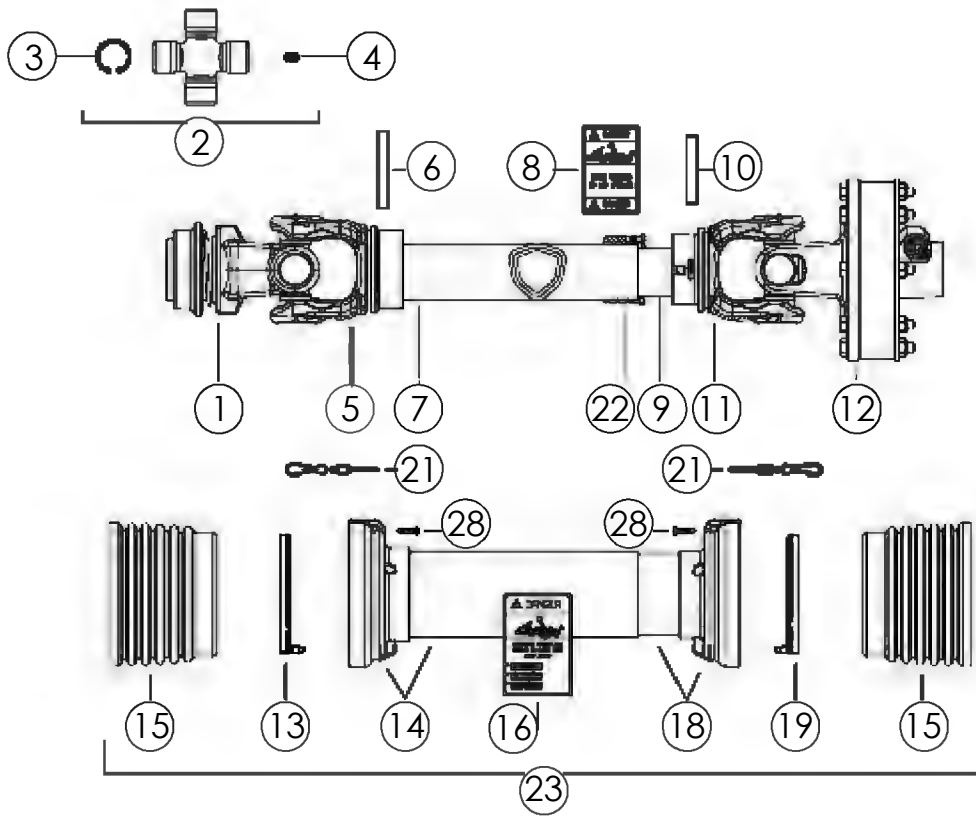

PTO-STANDARD 1.375*-21 #306403 1.75-20 #306404

ITEM	PART NO	DESCRIPTION	QTY
1	54198	YOKE-STD 1.375	1
	69866	YOKE-STD 1.75	
2	305445	CROSS KIT	2
3		CIRCLIP	8
4		GREASE NIPPLE	2
5	306407	YOKE-OUTER TUBE	1
6	306408	FLEXIBLE PIN	1
7	306409	TUBE OUTER	1
8	63293	DECAL-DRIVELINE	1
9	306410	TUBE INNER	1
10	55367	FLEXIBLE PIN	1
11	306411	YOKE INNER TUBE	1
12	305198	CLUTCH-TORQUE LIMITER	1
13	68746	BRG RING-OUTER SHIELD	1
14	306413	SHIELD CONE-OUTER	1
15	306412	OUTER SHIELD	1
16	63294	DECAL-DRIVELINE	1
17	68748	SCREW-SELF TAPPING	6
18	306414	CONE SET-INNER SHIELD	1
19	68752	BRG RING-INNER SHIELD	1
20	69871	KIT-BALL COLLAR 1.375	1
	69872	KIT-BALL COLLAR 1.75	
21	69873	CHAIN-COMPLETE	2
22	306415	COLLAR-GREASE	1
23	306406	KIT-SHIELD COMPLETE W/CHAINS	1

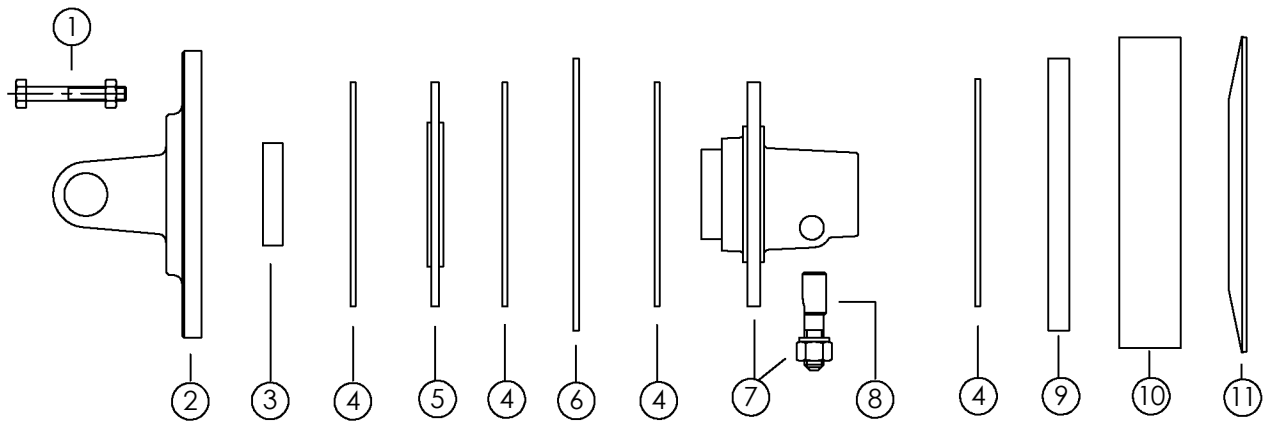

CLUTCH TORQUE LIMITER #305196(CV) & #305198(STD)			
ITEM	PART NO.	DESCRIPTION	QTY
1	63300	SCREW	8
2	69693	YOKE-FLANGE (CV)	1
	69864	YOKE-FLANGE (STD)	
3	63295	BUSHING	1
4	69692	LINING	4
5	69858	PLATE-LINING	1
6	69859	PLATE-INNER	1
7	69860	HUB	1
8	68782	KIT-TAPER PIN	1
9	69861	PLATE-THRUST	1
10	69862	SPACER	1
11	305197	SPRING	1

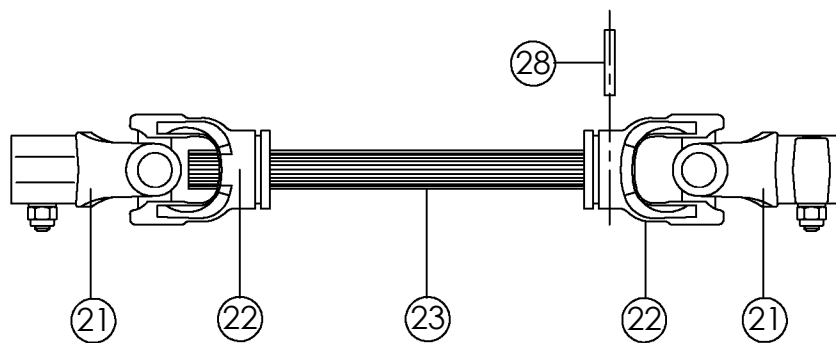
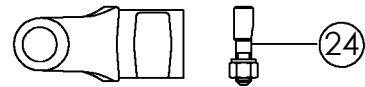
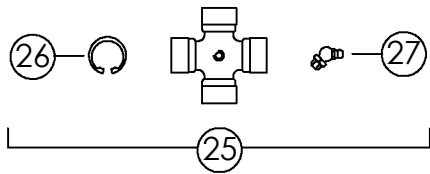
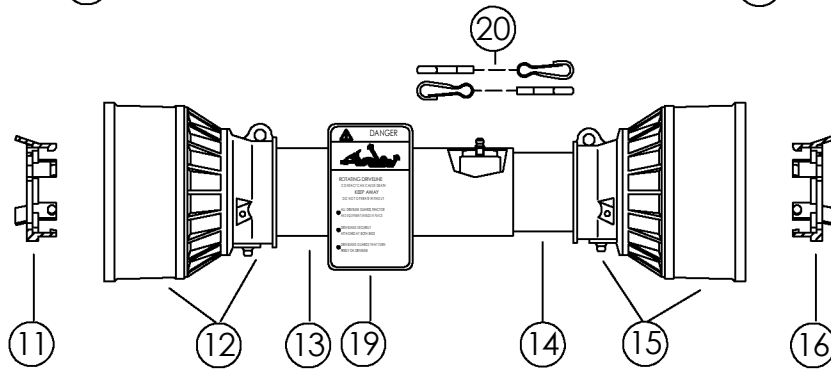
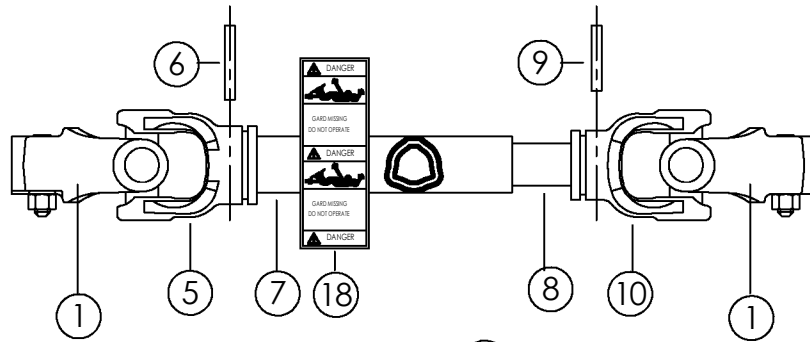
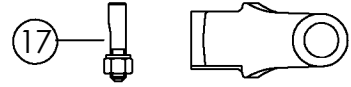
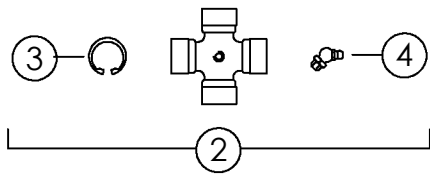

FRONT DRIVELINE #52399 & #68604

ITEM	PART NO.	DESCRIPTION	52399	68604
1	68731	TRACTOR YOKE	2	2
2	54235	CROSS KIT	2	2
3	55361	SNAP RING	8	8
4	63440	GREASE ZERK	2	2
5	54242	OUTER TUBE YOKE	1	1
6	55364	ROLL PIN	1	1
7	63595	OUTER DRIVE TUBE	1	-
	63602	OUTER DRIVE TUBE	-	1
8	63596	INNER DRIVE TUBE	1	-
	63603	INNER DRIVE TUBE	-	1
9	55367	ROLL PIN	1	1
10	54234	INNER TUBE YOKE	1	1
11	54238	BEARING RING - OUTER SHIELD	1	1
12	55374	OUTER SHIELD CONE	1	1
13	63597	OUTER SHIELD TUBE	1	-
	63604	OUTER SHIELD TUBE	-	1
14	63598	INNER SHIELD TUBE	1	-
	63605	INNER SHIELD TUBE	-	1
15	55320	INNER SHIELD CONE	1	1
16	54240	BEARING RING - INNER SHIELD	1	1
17	63594	TAPER PIN KIT	2	2
18	63293	DECAL-DRIVELINE	1	1
19	63294	DECAL-DRIVELINE	1	1
20	69873	CHAIN-COMPLETE (STD)	2	2

SIDE DRIVELINE #52397

ITEM	PART NO.	DESCRIPTION		QTY
21	68731	TRACTOR YOKE		2
22	54244	YOKE		2
23	63593	SHAFT-SPLINED		1
24	63594	TAPER PIN KIT		2
25	54235	CROSS KIT		2
26	55361	SNAP RING		8
27	63440	GREASE ZERK		2
28	63472	PIN-ROLL		1

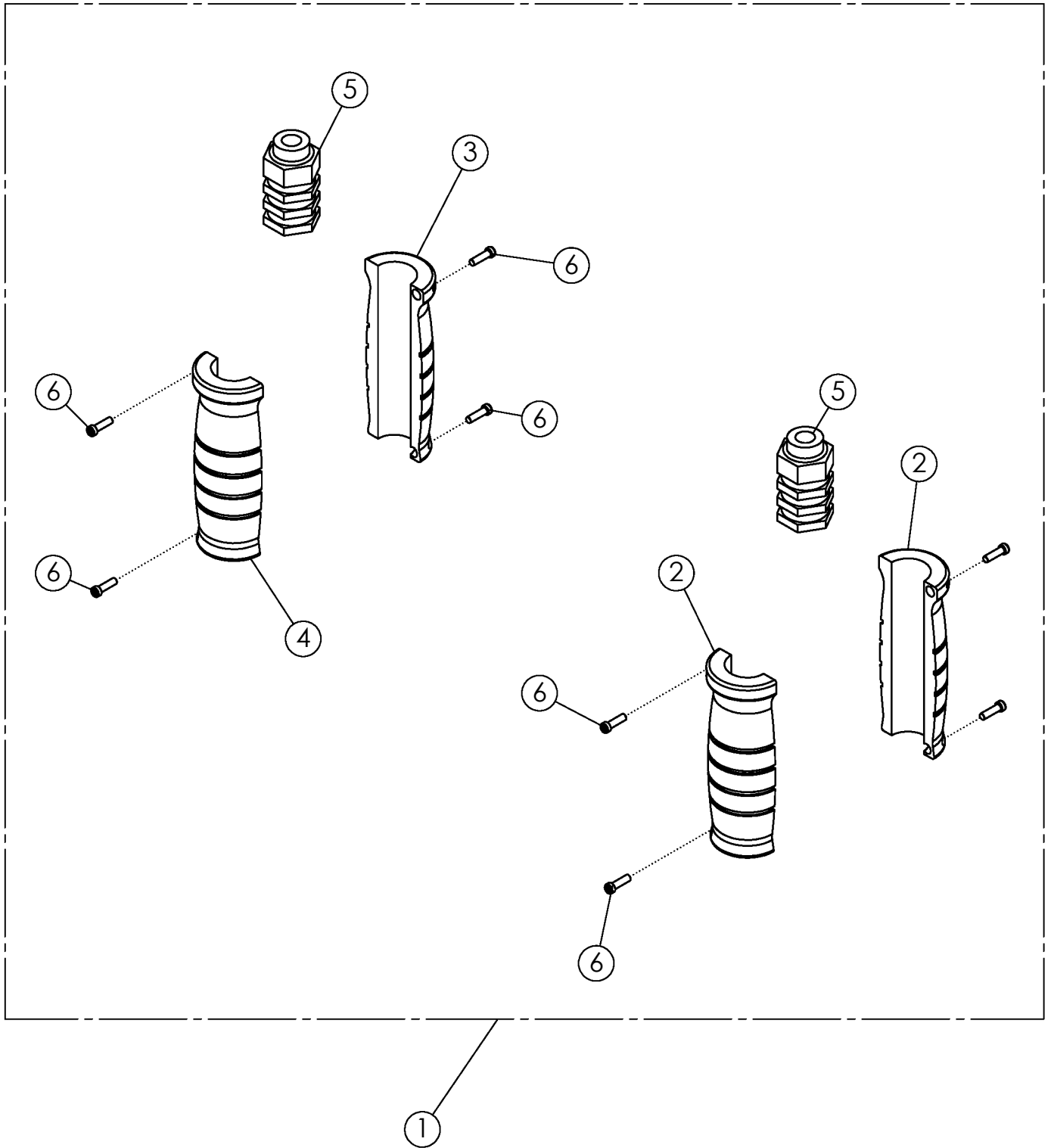

HYDRAULIC LABEL ASSY

ITEM	PART NO.	DESCRIPTION	QTY
1	301920*	HYD LABEL: .50 ORANGE/GRAY SET	1
	301902*	HYD LABEL: .50 BLUE/GRAY SET	
	301917*	HYD LABEL: .50 YELLOW/GRAY SET	
	301914*	HYD LABEL: .50 GREEN/GRAY SET	
	301911*	HYD LABEL: .50 BLACK/GRAY SET	
	301908*	HYD LABEL: .50 RED/GRAY SET	
	302230*	HYD LABEL: .50 RED/GREEN SET	
	302226*	HYD LABEL: .50 BLACK/ORANGE SET	
	302227*	HYD LABEL: .50 BLUE/YELLOW SET	
	301923*	HYD LABEL: .75 GREEN/GRAY SET	
	301928*	HYD LABEL: .75 YELLOW/GRAY SET	
2	301915	HYD LABEL: .50 GREEN HALF EXTEND	2
	301903	HYD LABEL: .50 BLUE HALF EXTEND	
	301909	HYD LABEL: .50 RED HALF EXTEND	
	301918	HYD LABEL: .50 YELLOW HALF EXTEND	
	301921	HYD LABEL: .50 ORANGE HALF EXTEND	
	301912	HYD LABEL: .50 BLACK HALF EXTEND	
	301921	HYD LABEL: .50 ORANGE HALF EXTEND	
	301925	HYD LABEL: .75 GREEN HALF EXTEND	
	301929	HYD LABEL: .75 YELLOW HALF EXTEND	
	302304	HYD LABEL: .75 RED HALF EXTEND	
3	301916	HYD LABEL: .50 GREEN HALF RETRACT	1
	301904	HYD LABEL: .50 BLUE HALF RETRACT	
	301910	HYD LABEL: .50 RED HALF RETRACT	
	301919	HYD LABEL: .50 YELLOW HALF RETRACT	
	301922	HYD LABEL: .50 ORANGE HALF RETRACT	
	301913	HYD LABEL: .50 BLACK HALF RETRACT	
	301922	HYD LABEL: .50 ORANGE HALF RETRACT	
	301926	HYD LABEL: .75 GREEN HALF RETRACT	
	301930	HYD LABEL: .75 YELLOW HALF RETRACT	
	302305	HYD LABEL: .75 RED HALF RETRACT	
4	301905	HYD LABEL: .50 GRAY HALF RETRACT	1
	301927	HYD LABEL: .75 GRAY HALF RETRACT	
5	301906	HYD LABEL: .50 CORE M & F O-RING	2
	301924	HYD LABEL: .75 CORE M & F O-RING	
6	301907	HYD LABEL: SET SCREW	8

* COMES WITH ITEMS 2 THRU 6

SHAFT REMOVED FOR CLARITY

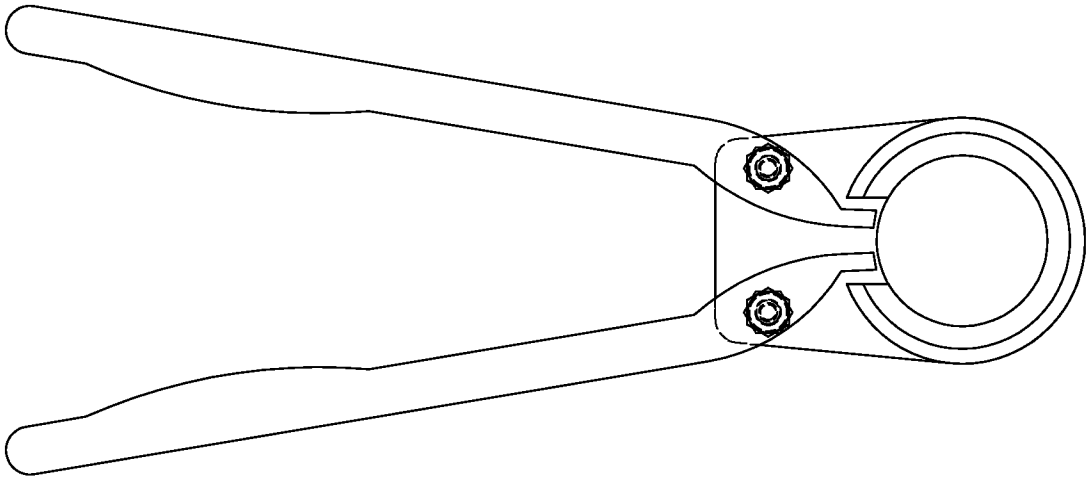
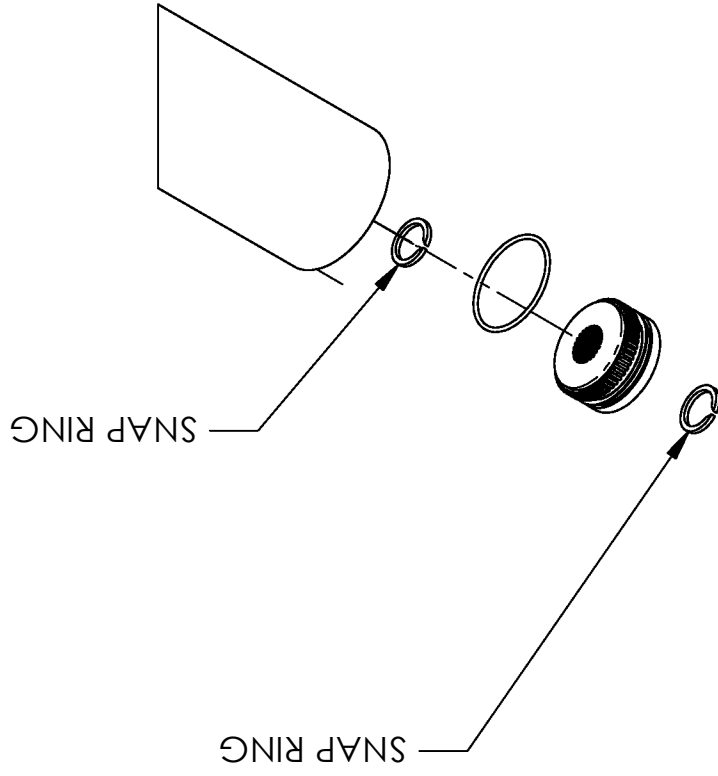

69055 SNAP RING PLIERS

