

# PARTS MANUAL

2024

2300 HARVESTER WHEEL

6 ROW 22

4 ROW 30

**Amity**  
TECHNOLOGY



2800 7<sup>th</sup> Avenue North  
Fargo, ND 58102

Phone: (701) 232-4199

Fax: (701) 234-1716

[www.amitytech.com](http://www.amitytech.com)



## TABLE OF CONTENTS

HITCH ASSEMBLY.....	1-2
LIFTER STRUT.....	3-10
ROW FINDER .....	11-14
GUARDS & SHIELDS.....	15-18
APRON SHAFT.....	19-22
PADDLE SHAFT.....	23-26
CLEANING ROLLS.....	27-30
CLEANING ROLL MOUNTING PACKAGE.....	31-32
MAIN DRIVE: ONBOARD OPTION.....	33-34
CLEANING ROLL DRIVE.....	35-36
APRON/PADDLE SHAFT DRIVE.....	37-38
TANK.....	39-40
ELEVATOR AND BOOM ASSEMBLY.....	41-44
BOOM EXTENSION 50MM/56MM (OPTIONAL).....	45-46
BOOM EXTENSION LONG 56MM (OPTIONAL).....	47-48
WHEEL ASSEMBLY.....	49-50
WHEEL CONVEYOR.....	51-54
WHEEL DRIVE.....	55-56
FRAME EXTENSION.....	57-60
WHEEL CLEANER (OPTIONAL).....	61-62
STANDARD REAR STRUTS 11.2 X 24.....	63-66
STANDARD REAR STRUTS 14.9 X 30 .....	67-68
STEERABLE REAR STRUTS .....	69-72
STEERABLE REAR STRUT 710/40R22.5.....	73-74
STEERABLE JD TOUCHSET KIT.....	75-76
ROW FINDER & HITCH HYDRAULICS.....	73-78
3-BANK VALVE W/ TOGGLE .....	79-80
SELF- CONTAINED HYDRAULIC SYSTEM .....	81-82
TRACTOR HYDRAULIC DRIVE.....	83-84
TANK HYDRAULICS.....	85-86
HYDRAULIC TANK.....	87-88
LIGHT KIT.....	89-90





## TABLE OF CONTENTS - (CONTINUED)

ACTIVE DEPTH CONTROL (ADC) ELECTRONICS .....	97-98
ADC ELECTRICAL SCHEMATIC .....	99-100
KT-JOYSTICK WITH MOUNT #303448 .....	101-102
ADC WANDS.....	103-104
ADC HYDRAULIC COMPONENTS .....	105-106
ADC HYDRAULIC COMMON .....	107-108
ADC HYDRAULICS.....	109-110
ADC ROW FINDER POWER SYSTEM.....	111-112
VALVE-ADC 3 BANK #302261.....	113-114
HARVESTER STAND #63357 (OPTIONAL).....	115-116
PTO DRIVELINE 1.38" – 21 SPLINE #301575.....	117-118
PTO DRIVELINE 1.75" – 20 SPLINE #301558.....	119-120
GEARBOX (1.81:1): ONBOARD OPTION #62396.....	121-122
SELECTOR VALVE #58470.....	123-124
ROW FINDER VALVE #301150.....	125-126
SPROCKET #54824.....	127-128
BELT TIGHTENER #56422.....	127-128
SLIP CLUTCH (IN-LINE) #57926.....	129-130
SLIP CLUTCH/SPROCKET #57993.....	129-130
SLIP CLUTCH/SPROCKET #58335.....	129-130
IDLER PULLEY #56406.....	131-132
SPROCKET IDLER #56851.....	131-132
REVERSE PULLEY #301822.....	133-134
ROLLERS.....	135-136
BELTED CHAIN LAP JOINT CONNECTION.....	137
REPAIR KIT - BELTED CHAIN #59180.....	138
BELTED CHAIN RIVET CUTTER.....	139-140
DECALS.....	141-148
HYDRUALIC LABEL ASSY.....	149-150

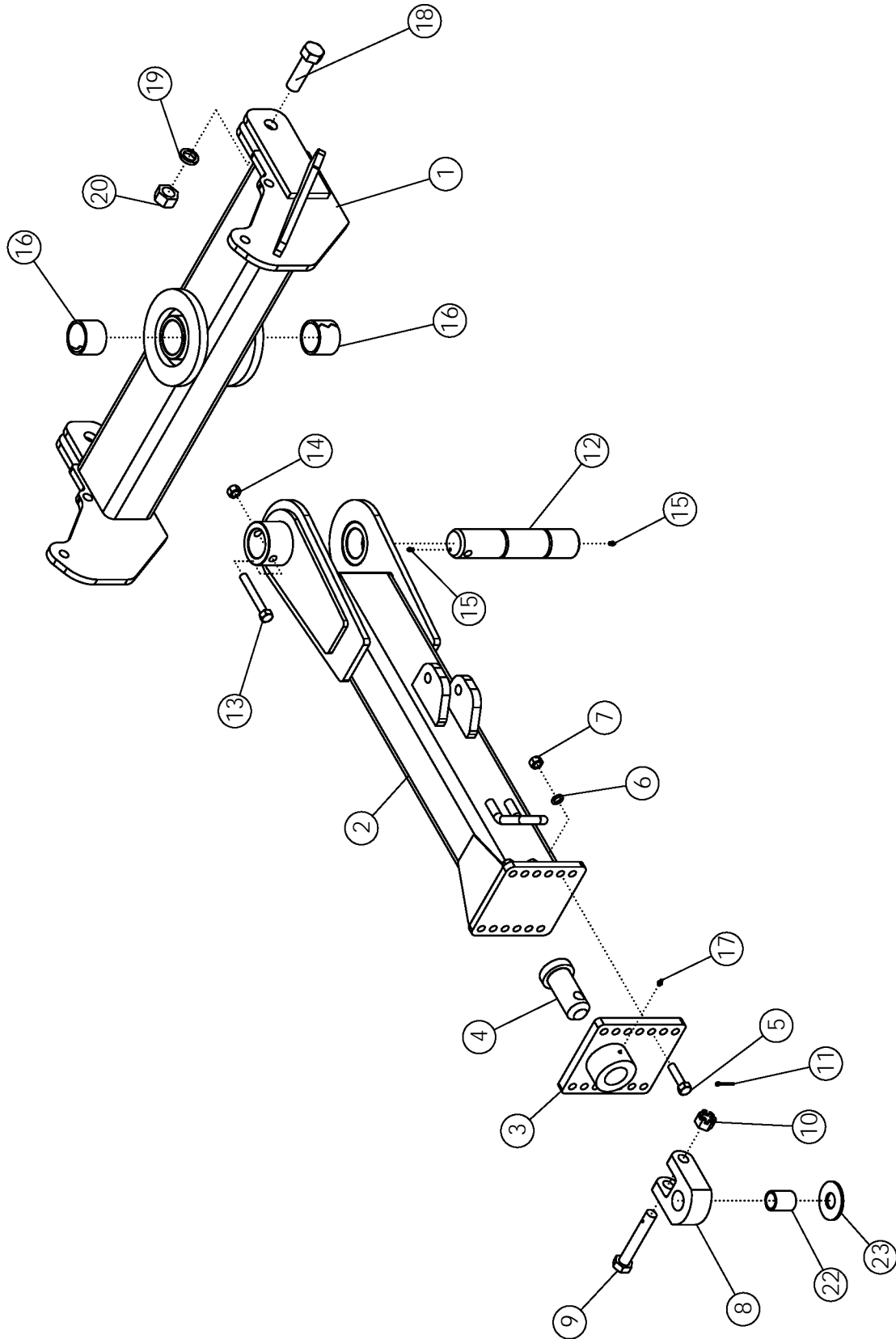

# HITCH ASSEMBLY

ITEM	PART NO.	DESCRIPTION	QTY
1	301660	WLDMT - HITCH PIVOT 6R/8R STD	1
2	301582	WLDMT - DRAWPOLE EXTENDED	1
3	57930	WLDMT-HITCH PLATE	1
4	62101	WLDMT-PIN	1
5	1012059	BOLT-HEX: .75 X 3.00 NC GR5 ZP	6
6	1012061	WASHER-LOCK: .75 ZP	6
7	1011620	NUT-HEX: .75 NC	6
8	64476	PLATE-PULL HITCH	1
9	62477	BOLT-HITCH DRILLED	1
10	62088	NUT-SLOTTED: 1.13 NC GR5 ZP	1
11	1013473	PIN-COTTER: .19 X 2.00 NP	1
12	301590	PIN-HITCH PIVOT	1
13	69911	BOLT-HEX: .75 X 5.5 NC GR5 ZP	1
14	1017000	NUT-TOPLOCK: .75 NC GR5 ZP	1
15	1030883	ZERK-GREASE: .3125 UNF STRAIGHT	2
16	301591	SPRING BUSHING 3.50 X 3.00 X 2.50	2
17	1011748	ZERK - GREASE: .25 UNF STRAIGHT	1
18	72021	BOLT-HEX: 1.38 X 4.50 NC GR5 ZP	2
19	1030760	WASHER-LOCK: 1.38 ZP	2
20	1030758	NUT-HEX: 1.38 NC ZP	2
21	69256	CHAIN-SAFETY 41000# (NOT SHOWN)	1
22	64614	TUBE-SPACER 2.0 X 1.63	1
23	58925	WASHER-HARDENED 4.000 X 1.625	1
	68645	WASHER-FLAT: SPCL 2.125 X 4.50 X .184	

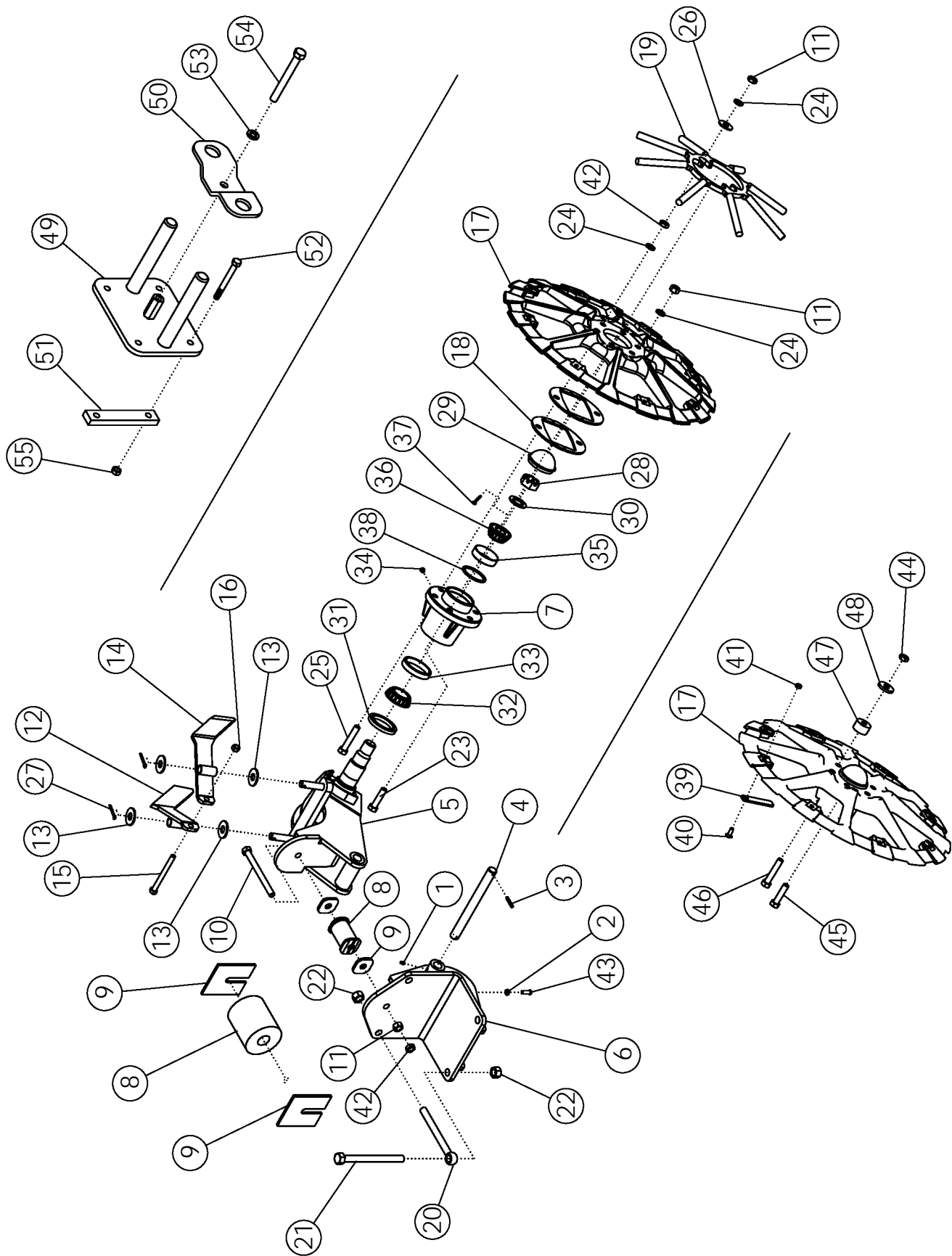

# LIFTER STRUT

ITEM	PART NO.	DESCRIPTION	QTY
1	1011748	ZERK - GREASE: .25 UNF	2
2	1013519	NUT-JAM: .38 NC GR2 ZP	2
3	59398	PIN-ROLL: .25 X 1.50 ZP	2
4	69907	SHAFT-STRUT	1
5	50142	WLDMT-STRUT SPINDLE ASSY	1
6	50146	WLDMT-STRUT BRACKET	1
7	63655	HUB-MACHINED	2
8	50134	WLDMT-SPACER ZP	1
	51542	BUMPER-RUBBER	1
9	50137	WASHER SQUARE ZP	2
	50139	PLATE-LIFTER STRUT SPACER ZP	4
10	1030761	BOLT-HEX: .63 X 7.00 NC GR 8 ZP	1
11	1011578	NUT-HEX: .63 NC GR5 ZP	13
12	50715	WLDMT-SCRAPER RH	1
13	1030702	WASHER-FLAT: .75 ZP	4
14	50716	WLDMT-SCRAPER LH	1
15	1011669	BOLT-HEX: .50 X 6.00 NC GR5 ZP	1
16	1027461	NUT-TOPLOCK: .50 NC GR5 ZP	1
17	69855	LIFTER WHEEL MACHINED	2
	300734	LIFTER WHEEL HARD PAINTED	
18	50747	PLATE-LIFTER WHEEL SPACER ZP	AR
19	63880	WLDMT-WHEEL FILLER (OPTIONAL)	2
20	64135	BOLT-EYE: .75 X 8.00 ZP	2
21	64136	BOLT-HEX: .75 X 8.50 NC GR5 ZP	2
22	1017000	NUT-TOPLOCK: .75 NC GR5 ZP	4
23	1013023	BOLT-HEX: .63 X 2.50 NC GR5 ZP	8
24	1011813	WASHER-LOCK: .63 ZP	16
25	65825	BOLT-HEX: .63 X 3.25 NC GR5 ZP	4
26	1013024	WASHER-FLAT: .63 ZP	4
27	1013473	PIN-COTTER: .19 X 2.00 NP	2
28	1016367	NUT-SPINDLE: 1.38 NF NP	2
29	63624	HUB CAP ROUNDED ZP	2
30	1030765	BUSHING-MACHINED: 1.38 NR 10 GA	2
31	53632	SEAL	2
32	53634	CONE-BEARING INNER	2
33	53636	CUP-BEARING INNER	2
34	1030766	ZERK - GREASE .13 NPT STRAIGHT	2
35	53635	CUP-BEARING OUTER	2
36	53633	CONE-BEARING OUTER	2
37	64012	PIN-COTTER: .19 X 3.00 NP	2

CONTINUE

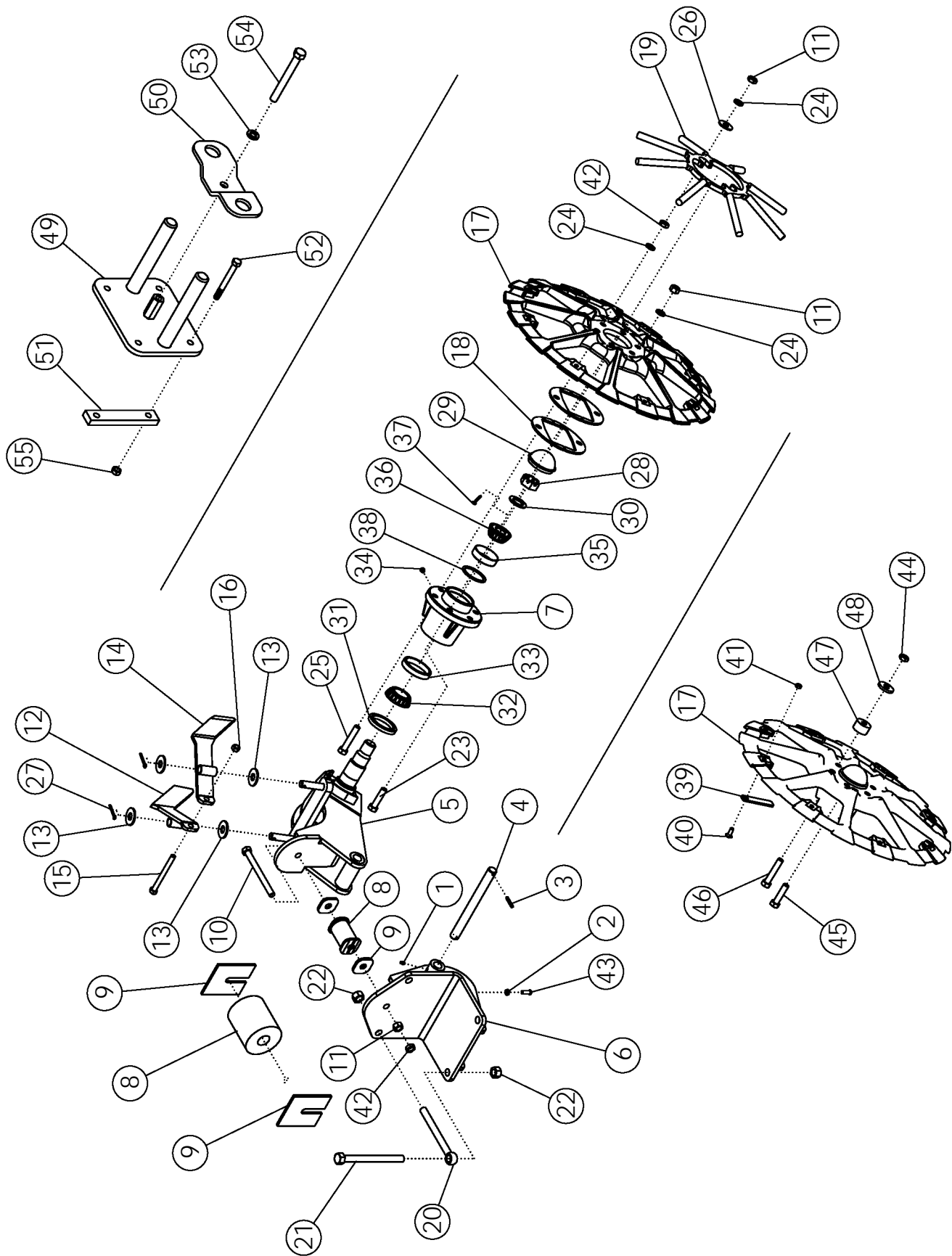

# LIFTER STRUT (CONTINUED)

ITEM	PART NO.	DESCRIPTION	QTY	
38	64674	RACE-SPACER (.120)	AR	
39	300097	PLATE-LIFTER WHEEL FILLER	16	
40	59488	BOLT-CRG: .38 X 1.00 NC GR5 ZP	16	
41	1016999	NUT-TOPLOCK: .38 NC GR5 ZP	16	
42	1026259	NUT-JAM: .63 NC GR2 ZP	5	
43	50813	SCREW-SET: SQ HD .38 X 1.00 ZP	2	
<b>OPTIONAL URETHANE BUSHING</b>				
44	1016595	NUT-TOPLOCK: .63 GR5 ZP	12	
45	59093	BOLT-HEX: .63 X 3.75 NC GR5 ZP	8	
46	1013935	BOLT-HEX: .63 X 4.50 NC GR5 ZP	4	
47	51705	BUSHING	12	
	301975	BUSHING-URETHANE .67"		
48	301324	WASHER-CUSTOM: .668 ID X 1.875 OD X .235	12	
<b>OPTIONAL WHEEL FILLER BRACKET</b>			6-8ROW	12 ROW
49	64658	WLDMT-WHEEL FILLER BRACKET	2	3
50	64659	PLATE-RETAINER	2	3
51	63372	BAR-BACKING	4	6
52	58176	BOLT-HEX: .38 X 3.50 NC GR5 ZP	8	12
53	1011581	WASHER-LOCK: .50 ZP	2	3
54	1011618	BOLT-HEX: .50 X 5.00 NC GR5 ZP	2	3
	1013682*	BOLT-HEX: .50 X 4.50 NC GR5 ZP	2	-
55	1016999	NUT-TOPLOCK: .38 NC GR5 ZP	8	12

\* 6 ROW ONLY

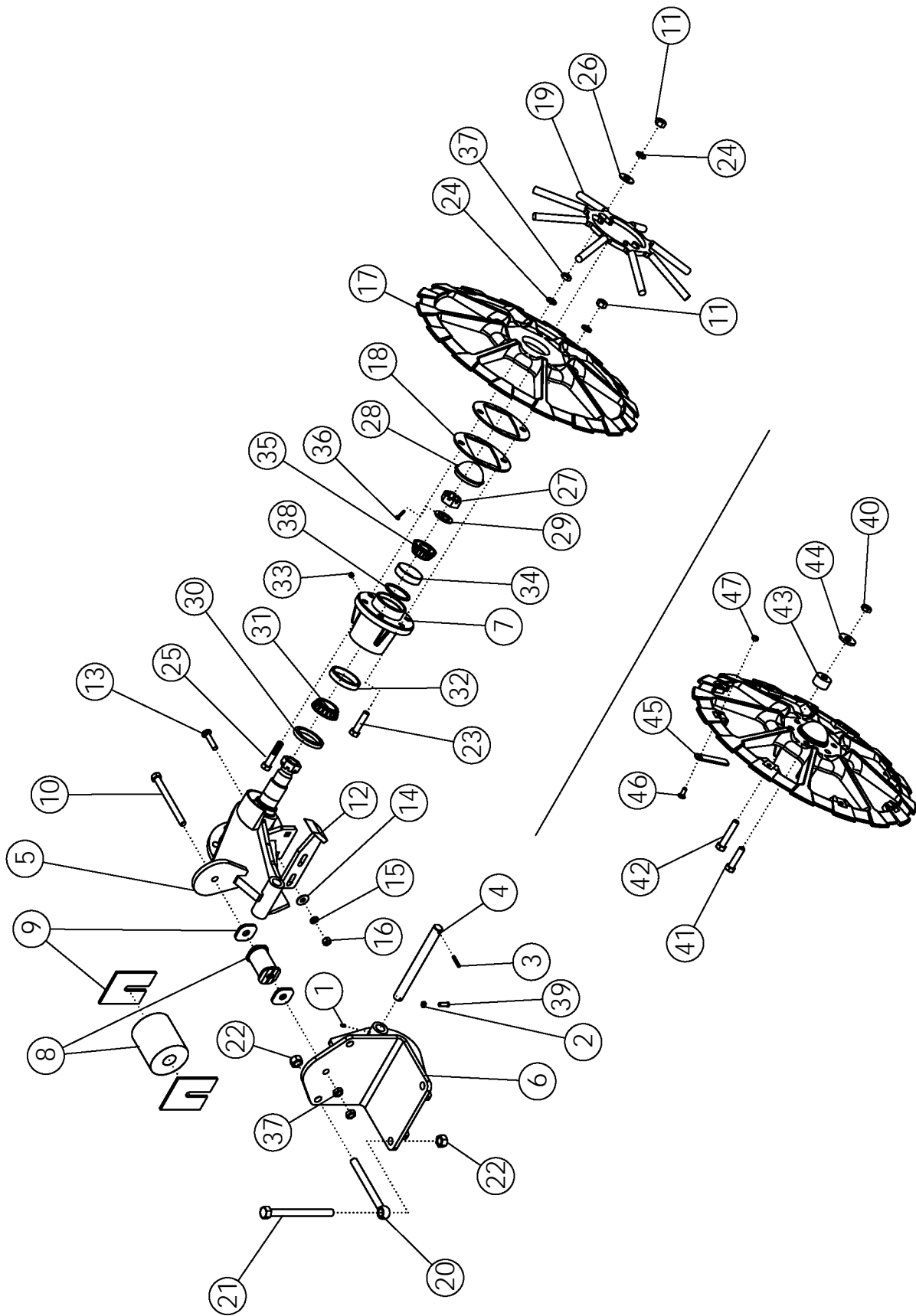



# LIFTER STRUT - BOTTOM SCRAPER OPTION

ITEM	PART NO.	DESCRIPTION	QTY
1	1011748	ZERK - GREASE: .25 UNF	2
2	1013519	NUT-JAM: .38 NC GR2 ZP	2
3	59398	PIN-ROLL: .25 X 1.50 ZP	2
4	69907	SHAFT-STRUT	1
5	68095	WLDMT-SP LIFTER STRUT STD	1
6	50146	WLDMT-STRUT BRACKET	1
7	63655	HUB-MACHINED	2
8	50134	WLDMT-SPACER ZP	1
	51542	BUMPER-RUBBER	1
9	50137	WASHER SQUARE ZP	2
	50139	PLATE ZP	4
10	1030761	BOLT-HEX: .63 X 7.00 NC GR 8 ZP	1
11	1011578	NUT-HEX: .63 NC GR5 ZP	13
12	64369	WLDMT-SCRAPER	2
13	64685	BOLT-CRG: .50 X 2.25 NC GR5 ZP	2
14	1014443	WASHER-FLAT: .50 ZP	2
15	1011581	WASHER-LOCK: .50 ZP	2
16	1011577	NUT-HEX: .50 NC GR5 ZP	2
17	69855	LIFTER WHEEL MACHINED	2
	300734	LIFTER WHEEL HARD PAINTED	
18	50747	PLATE-LIFTER WHEEL SPACER ZP	AR
19	63880	WLDMT-WHEEL FILLER (OPTIONAL)	2
20	64135	BOLT-EYE: .75 X 8.00 ZP	2
21	64136	BOLT-HEX: .75 X 8.50 NC GR5 ZP	2
22	1017000	NUT-TOPLOCK: .75 NC GR5 ZP	4
23	1013023	BOLT-HEX: .63 X 2.50 NC GR5 ZP	8
24	1011813	WASHER-LOCK: .63 ZP	16
25	65825	BOLT-HEX: .63 X 3.25 NC GR5 ZP	4
26	1013024	WASHER-FLAT: .63 ZP	4
27	1016367	NUT-SPINDLE: 1.38 NF NP	2
28	63624	HUB CAP ROUNDED ZP	2
29	1030765	BUSHING-MACHINED: 1.38 NR 10 GA	2
30	53632	SEAL	2
31	53634	CONE-BEARING INNER	2
32	53636	CUP-BEARING INNER	2
33	1030766	ZERK - GREASE .13 NPT STRAIGHT	2
34	53635	CUP-BEARING OUTER	2
35	53633	CONE-BEARING OUTER	2
36	64012	PIN-COTTER: .19 X 3.00 NP	2
37	1026259	NUT-JAM: .63 NC ZP	5
38	64674	RACE-SPACER (.120)	AR
39	50813	SCREW-SET: SQ HD .38 X 1.00 ZP	2

CONTINUE

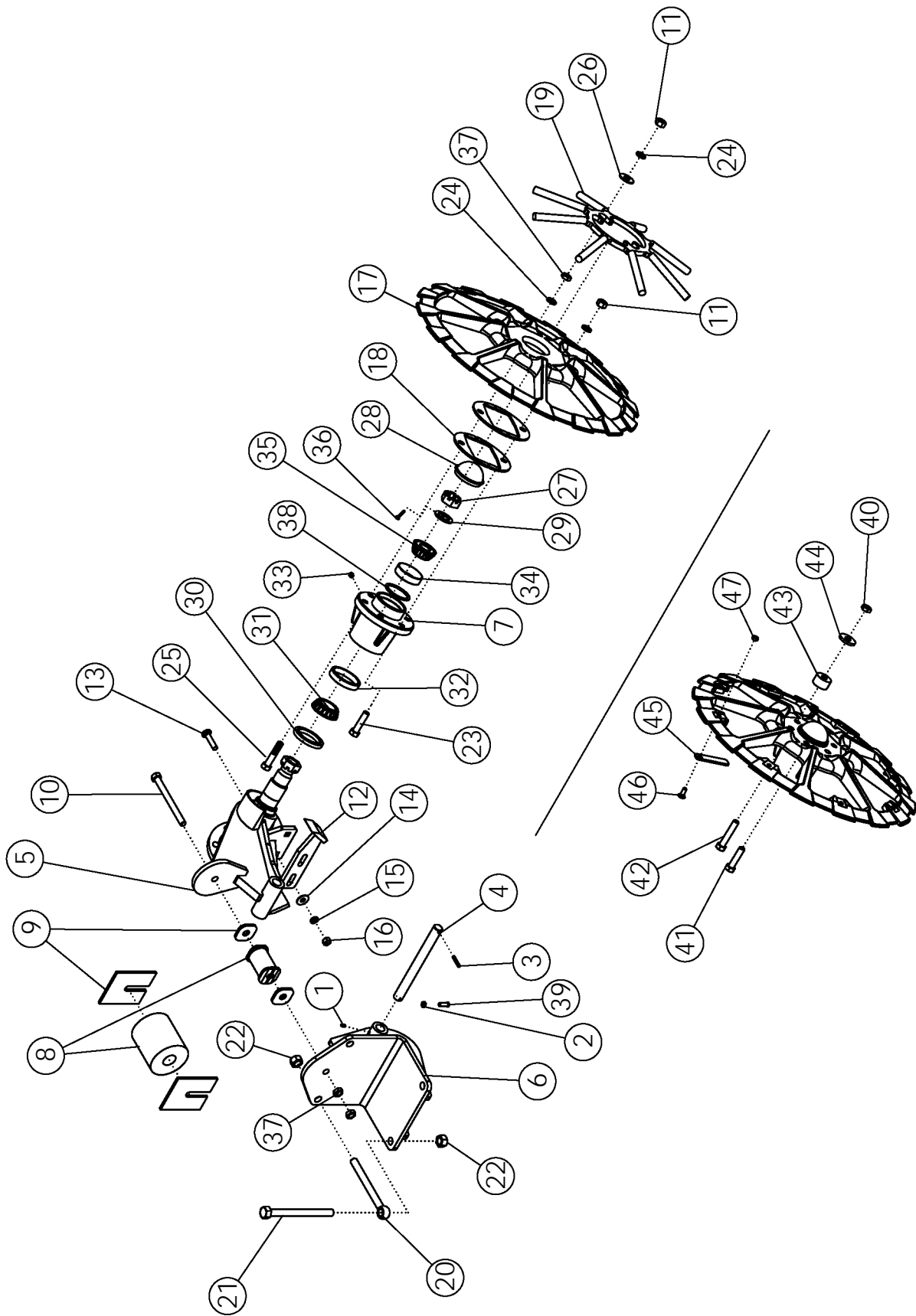

# LIFTER STRUT - BOTTOM SCRAPER (CONTINUED)

ITEM	PART NO.	DESCRIPTION	QTY
<hr/>			
<b>OPTIONAL URETHANE BUSHING</b>			
<hr/>			
40	1016595	NUT-TOPLOCK: .63 GR5 ZP	12
41	59093	BOLT-HEX: .63 X 3.75 NC GR5 ZP	8
42	1013935	BOLT-HEX: .63 X 4.50 NC GR5 ZP	4
43	51705	BUSHING	12
	301975	BUSHING-URETHANE .67"	
44	301324	WASHER-CUSTOM: .668 ID X 1.875 OD X .235 TH	12
<hr/>			
<b>RIM FILLER KIT</b>			
<hr/>			
45	300097	PLATE-LIFTER WHEEL FILLER	16
46	59488	BOLT-CRG: .38 X 1.00 NC GR5 ZP	16
47	1016999	NUT-TOPLOCK: .38 NC GR5 ZP	16



# HYDRUALIC ROW FINDER

ITEM	PART NO.	DESCRIPTION	QTY
1	52567	BUSHING-ZP	1
2	62520	ASSY-ROW FINDER MAIN FRAME W/BUSHINGS	1
3	55206	BUSHING-MACH: 1.25 NR 14GA	9
4	51139	ASSY-WLDMT-SWIVEL W/BUSHINGS	1
5	51130	WLDMT-FLIPPER	1
6	301748	BOLT-HEX: .31 X 2.50 NC GR8 ZP	5
7	301749	NUT-TOPLOCK: .31 NC GR8 ZP	5
8	51690	SHAFT ZP	1
9	52566	TENSIONER ARM	1
10	51131	SENSOR ARM-L.H.	1
11	52564	SENSOR ARM-R.H.	1
12	1030797	PIN-COTTER: .19 X 1.75 NP	2
13	51137	COLLAR	1
14	52565	ADJUSTMENT BOLT	1
15	1013004	WASHER-FLAT: SAE .63 ZP	5
16	1013024	WASHER-FLAT: .63 ZP	2
17	51692	SPRING: .21 X 1.44 OD X 6.00 15 COILS	1
18	1026259	NUT-JAM: .63 NC GR2 ZP	3
19	1011578	NUT-HEX: .63 NC GR2 ZP	4
20	51691	EYEBOLT: .63 X 3.25 ZP	1
21	1016595	NUT-TOPLOCK: .63 NC GR5 ZP	1
22	1011601	BOLT-HEX: .38 X 1.25 NC GR5 ZP	2
23	1011600	BOLT-HEX: .38 X 1.00 NC GR5 ZP	1
24	51129	PLATE-ADJUSTMENT	4
25	1014608	WASHER-FLT: SAE .38 ZP	1
26	1020416	WASHER-FLAT: .25 ZP	2
27	1011583	WASHER-FLAT: .31 ZP	2
28	1011586	WASHER-LOCK: .38 ZP	2
29	1029115	WASHER-LOCK: .31 ZP	2
30	1011576	NUT-HEX: .38 NC GR2 ZP	2
31	1011575	NUT-HEX: .31 NC GR2 ZP	2
32	52582	SPRING CAP	4
33	51689	SPRING-ROW FINDER PAINTED	2
34	1019828	BOLT-HEX: .38 X 2.75 NC GR5 ZP	2
35	1016999	NUT-TOPLOCK: .38 NC GR5 ZP	7
36	51128	SPRING PLATE	1
37	1030792	NUT-JAM: .38 NF GR2 ZP	1
38	301150	VALVE-ROWFINDER O/C	1
39	301750	WLDMT-STUD RF LONG ZP	1
40	64157	PIN-ROLL: .19 X 1.125 ZP	1

CONTINUED

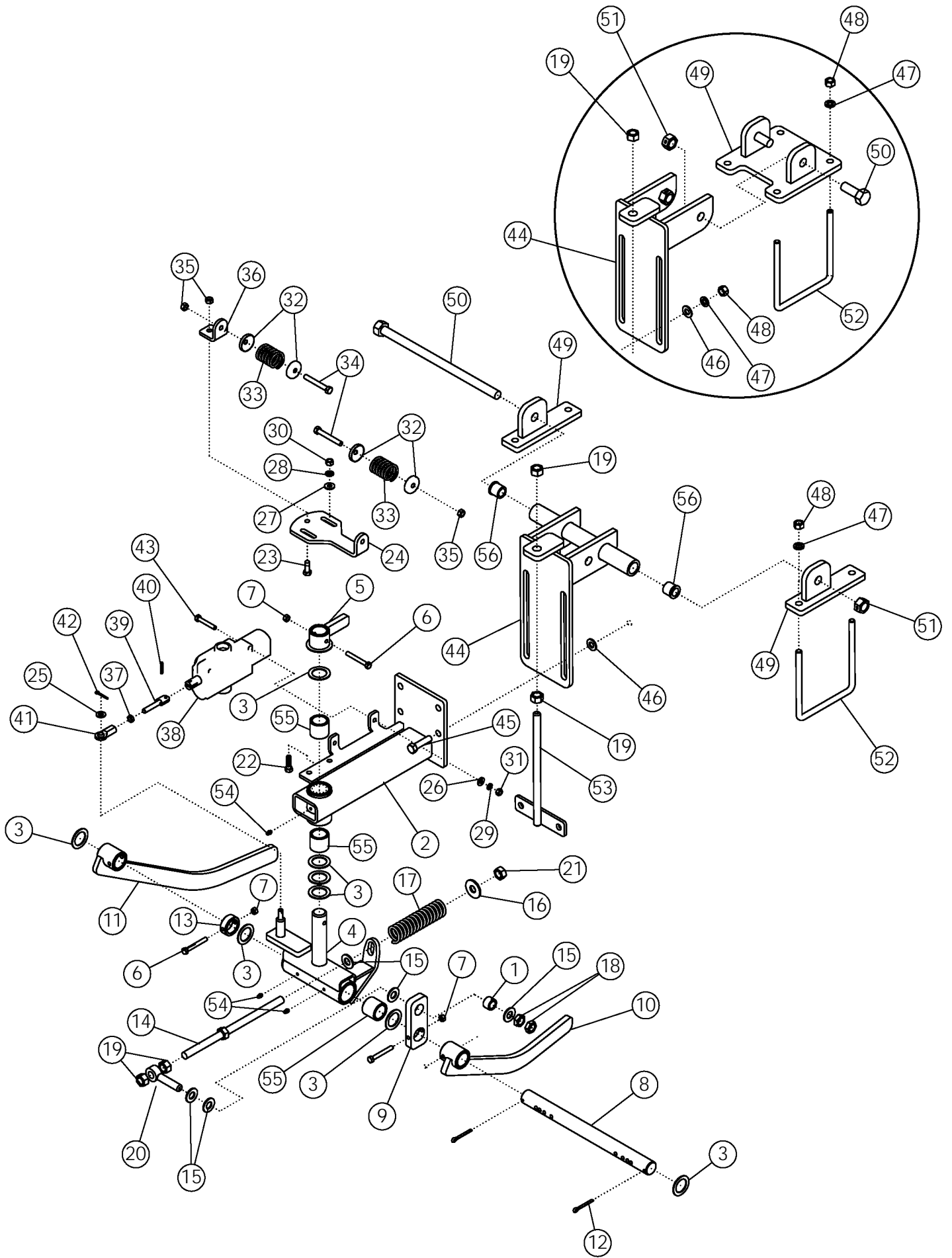

## HYDRAULIC ROW FINDER (CONTINUED)

ITEM	PART NO.	DESCRIPTION	QTY
41	51136	UNIBALL COUPLING	1
42	1029137	PIN-COTTER: .13 X 1.00 ZP	1
43	1011285	BOLT-HEX: .31 X 2.00 NC	2
44	63661	WLDMT-MOUNTING BRACKET	1
	52181	WLDMT-BRACKET	
45	1011609	BOLT-HEX: .50 X 2.00 NC GR5 ZP	4
46	1011584	WASHER-FLAT: SAE .50 ZP	4
47	1011581	WASHER-LOCK: .50 ZP	8
48	1011577	NUT-HEX: .50 NC GR2 ZP	12
49	63662	WLDMT-MOUNTING SUPPORT	2
	62871	WLDMT-BRACKET	1
50	63664	BOLT-HEX: .75 X 14.00 NC GR5 ZP	1
	1012060	BOLT-HEX: .75 X 2.00 NC GR5 ZP	2
51	1013537	NUT-TOPLOCK: .75 NC GR5 ZP	2
52	53984	U-BOLT 1/2 X 7 X 6 X 7	2
53	62882	WLDMT-TIGHTENER 11.125" ZP	1
54	1011748	ZERK - GREASE	3
55	56939	BUSHING-OILITE:1.25 X 1.625 X 1.50L	4
56	52654	BUSHING	2

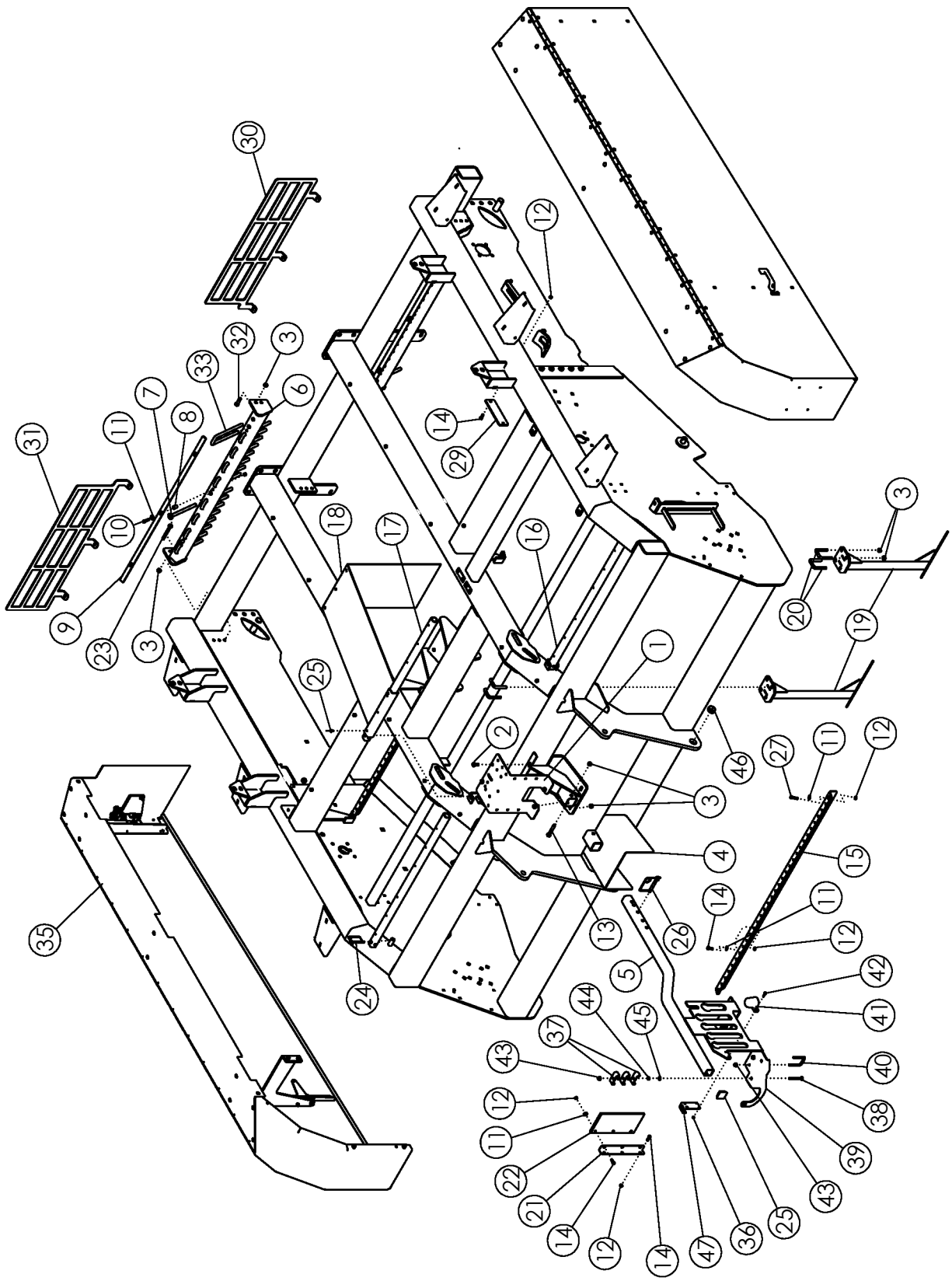



## GUARDS AND SHIELDS

ITEM	PART NO.	DESCRIPTION	QTY
1	62883	PLATE-HOSE MOUNT	1
2	1011096	BOLT-HEX: .50 X 1.00 NC GR5 ZP	4
3	1027461	NUT-TOPLOCK: .50 NC GR5 ZP	33
4	63354	WLDMT-PTO SHIELD	1
5	301135	TUBE-HYD HOSE HOLDER PC	1
6	58008	WLDMT-MOUNT	2
7	58009	ROD ZP	2
8	58446	SPACER ZP	6
9	58447	STRAP	2
10	1015174	BOLT-HEX: .38 X 2.50 NC GR5 ZP	6
11	1011828	WASHER-FLAT .38 ZP	34
12	1016999	NUT-TOPLOCK .38 NC GR5 ZP	50
13	1011611	BOLT-HEX: .50 X 3.00 GR5 ZP	1
14	1011600	BOLT-HEX: .38 X 1.00 NC GR5 ZP	34
15	53247	MOUNT-TARP 6R	2
16	57720	TUBE-OUTER APRON 6R	2
17	57721	TUBE-INNER APRON 6R/8R	1
18	58961	APRON-RUBBER	6
19	62378	WLDMT - DEFLECTOR	5
20	65658	U-BOLT: .50 X 3.00 X 2.06 X 3.00	10
21	51331	ANGLE	2
22	51680	DEFLECTOR-RUBBER	2
23	1032507	BOLT-HEX: .50 X 4.00 NC GR5 ZP	4
24	59101	SPRING PIN .38 X 3.00	3
25	301129	CAPLUG-2" SQ	1
26	52408	SPRING PIN .50 X 3.50	1
27	1011602	BOLT-HEX: .38 X 1.50 NC GR5 ZP	4
28	1011974	POP-RIVET: .19 X .531 ZP	18
29	63501	PLATE-COVER	2
30	300021	PLATE-GUARD LH 6R	1
31	300022	PLATE-GUARD RH 6R	1
32	1011608	BOLT-HEX: .50 X 1.75 NC GR5 ZP	4
33	69117	U ROD ZP	18
34	69265	ASSY-LH DOOR 6R & 8R	1
35	69350	ASSY-RH DOOR 6R & 8R	1
36	1030946	NUT-TOPLOCK: .25 NC GR5 ZP	2
37	50714	CLAMP 1/2" ZP	12
38	1030880	BOLT-CRG: .38 X 3.50 NC GR5 ZP	4
	1030882	BOLT-CRG: .38 X 2.50 NC GR5 ZP	
39	303797	PLATE-HYD HOSE HOLDER W/ PTO CATCH	1
40	33162	U-BOLT: .375 X 3 X 2 X 3	2
41	223329	HOLDER-LIGHT PLUG	1
42	1013423	BOLT-HEX: .25 X 1.00 NC GR5 ZP	2
43	303731	NUT-FLANGE: TOPLOCK .38 NC YZP	8
44	1013519	NUT-JAM: .38 NC GR2 ZP	12
45	1014608	WASHER-FLAT: SAE .38 ZP	4
46	304037	BUSHING-SPRING 1.625 X 1.375 X 0.75L	2
47	307680	PLATE-PTO SHEAR SS	1

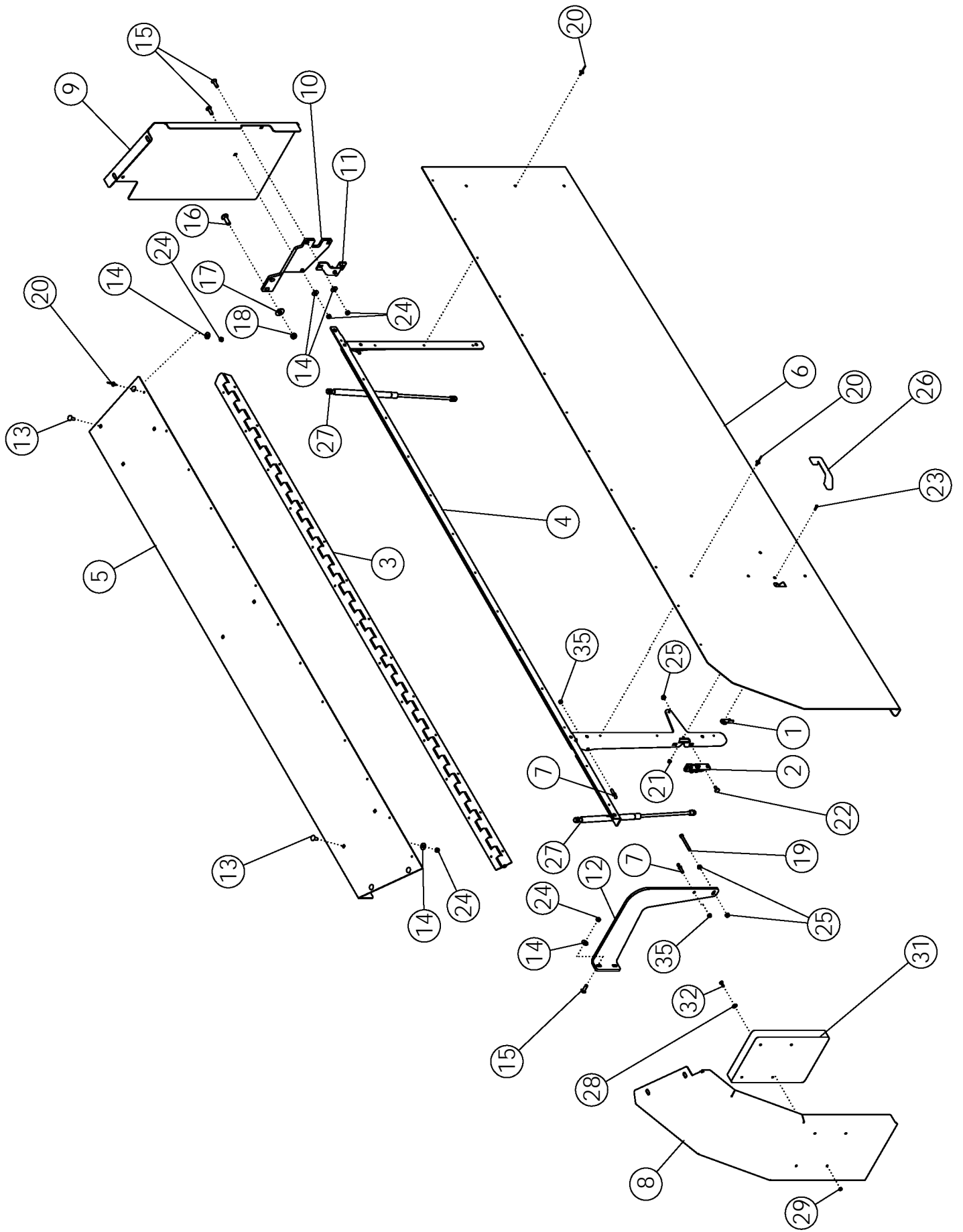

# DOOR ASSEMBLY

ITEM	PART NO.	DESCRIPTION	QTY
1	69284	LEVER-HRV LATCH ZP	1
2	69283	LATCH-DLP ROTARY SLAM	1
3	69286	HINGE-108 HEAVY CONTINUOUS	1
4	69266	WLDMT-DOOR FRAME LH	1
	69348	WLDMT-DOOR FRAME RH (NOT SHOWN)	
5	69271	PANEL-SHIELD TOP LH PC	1
	69316	PANEL-SHIELD TOP RH PC (NOT SHOWN)	
6	69270	SHEET-SHIELD DOOR LH PC	1
	69319	SHEET-SHIELD DOOR RH PC (NOT SHOWN)	
7	69278	STUD-BALL .31-18NC X .75	4
8	69272	PANEL-SHIELD FRONT LH PC	1
	69317	PANEL-SHIELD FRONT RH PC (NOT SHOWN)	
9	69273	PANEL-SHIELD REAR LH PC	1
	69318	PANEL-SHIELD REAR RH PC (NOT SHOWN)	
10	69274	PLATE-SUPPORT REAR LH	1
	69344	PLATE-SUPPORT REAR RH (NOT SHOWN)	
11	69275	BRACKET-SPRING REAR	1
12	69277	BRACKET-SPRING FRONT LH	1
	69320	BRACKET-SPRING FRONT RH (NOT SHOWN)	
13	59488	BOLT-CRG: .38 X 1.00 NC GR5 ZP	10
14	1011828	WASHER-FLAT .38 ZP	17
15	1016362	BOLT-CRG: .38 X 1.25 NC GR5 ZP	7
16	1011660	BOLT-CRG: .50 X 1.50 NC GR5 ZP	2
17	1014443	WASHER-FLAT: .50 ZP	2
18	1027461	NUT-TOPLOCK: .50 NC GR5 ZP	2
19	1029448	BOLT-HEX .31 X 3.00 NC GR5 ZP	1
20	1011974	RIVET-POP: .19 X .531 ZP	32
21	1026591	NUT-K-LOCK: #10-24 NC GR2 ZP	2
22	65702	BOLT-CRG: .31 X .75 NC GR5 ZP	2
23	67078	SCREW-P-H: 10-24 X .75 NC GR2 ZP	2
24	1016999	NUT-TOPLOCK: .38 NC GR5 ZP	17
25	67077	NUT-FLANGE SERR .31 NC ZP GR2	4
26	69285	HANDLE-MOLDED GRAB	1
27	69282	SPRING-700N GAS	2
28	1020416	WASHER-FLAT: .25 ZP	4
29	1030946	NUT-TOPLOCK: .25 NC GR5 ZP	4
30	1030700	NUT-TOPLOCK: .31 NC GR5 ZP	4
31	64635	CASE-MANUAL STORAGE	1
32	1011595	BOLT-HEX: .25 X .75 NC GR5 ZP	4

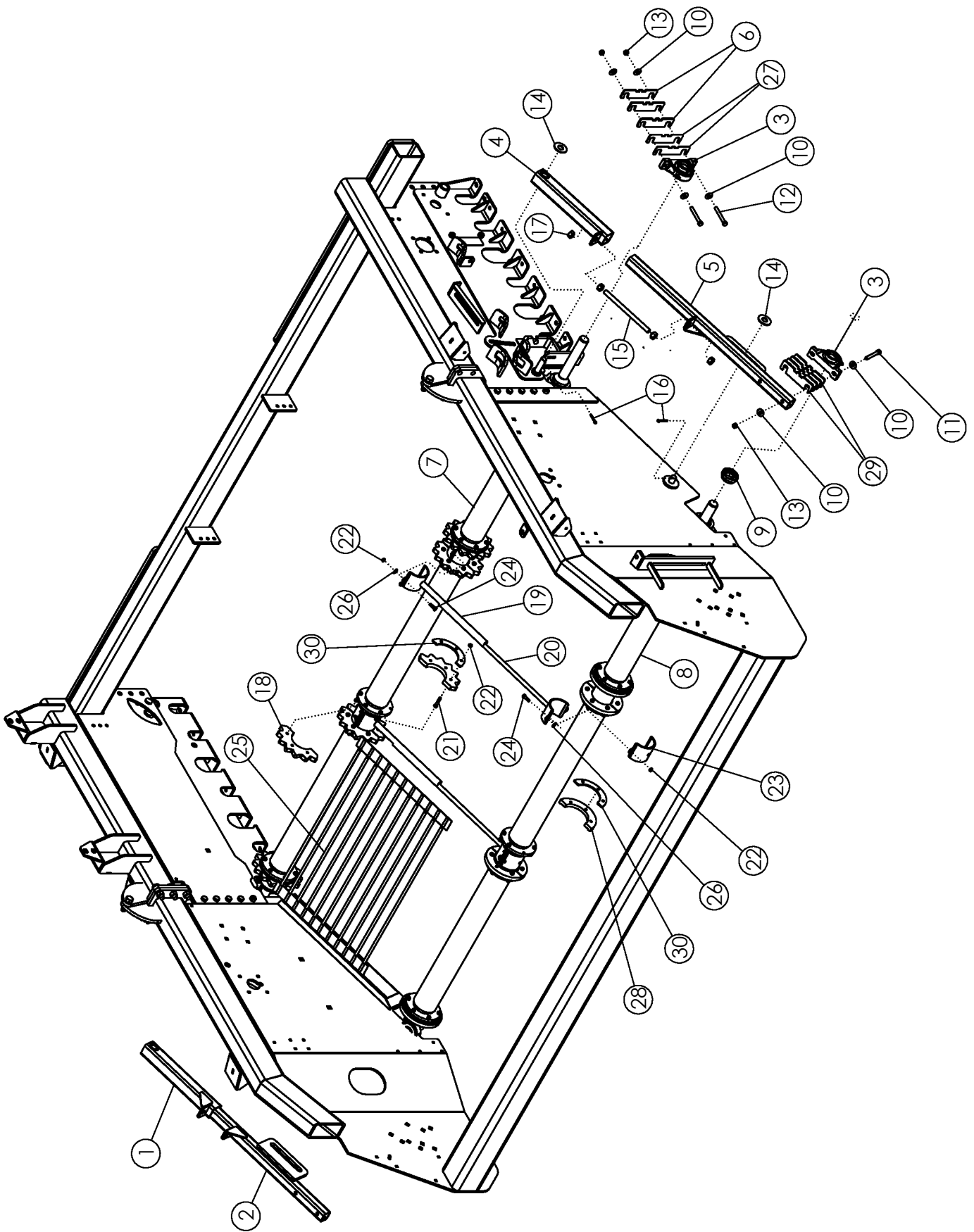

## APRON SHAFT - BELTED CHAIN

ITEM	PART NO.		QTY
1	56693	WLDMT-ARMRH	1
2	56698	WLDMT-SLIDE RH	1
3	52405	BEARING-PILLOW 1.75	4
4	56692	WLDMT-ARMLH	1
5	56697	WLDMT-SLIDE LH	1
6	56672	SHIM-BEARING ZP	AR
7	63352	WLDMT-TOP APRON SHAFT	1
8	63394	WLDMT-BOTTOM APRON SHAFT	1
9	52382	SEAL PROTECTOR 1.75	2
10	1014443	WASHER-FLAT: .50 ZP	16
11	1029104	BOLT-HEX: .50 X 3.75 NC GR5 ZP	4
12	1032507	BOLT-HEX: .50 X 4.00 NC GR5 ZP	4
13	1027461	NUT-TOPLOCK: .50 NC GR5 ZP	8
14	1020685	WASHER-FLAT: 1.00 ZP	4
15	56718	ROD-THREADED ZP	2
16	1016944	PIN-COTTER: .25 X 2.00 ZP	4
17	1011620	NUT-HEX: .75 NC GR2 ZP	8
18	301075	SPROCKET-SPLIT COUNTERBORE (PAIR)	6
	302846	SPROCKET-SPLIT 56MM 5/8 ROD 14T URETHANE HALF	
19	301532	WLDMT-UPPER FILLER 4" SHAFT WIDE	2
20	301531	WLDMT-LOWER FILLER 4" SHAFT WIDE	2
21	1011603	BOLT-HEX: .38 X 1.75 NC GR5 ZP	72
22	1016999	NUT-TOPLOCK: .38 NC GR5 ZP	80
23	301533	CLAMP-FILLER 4" SHAFT WIDE PAINTED	4
24	64991	BOLT-HEX: .38 X 1.25 NC GR8 ZP	8
25	59560	BELT 1/2 X 42 X 56MM 48LPR	3
	69659	BELT 5/8 X 42 X 56MM 48LPR	
26	1011828	WASHER-FLAT: .38 ZP	8
27	300146	SHIM-BEARING .120 THICK	4
28	63414	DISC-SPLIT COUNTER BORED	6
29	56672	SHIM-BEARING ZP (PLASTIC PADDLE OPTION)	8
30	303216	DISC-HALF WEAR PLATE 4"	16



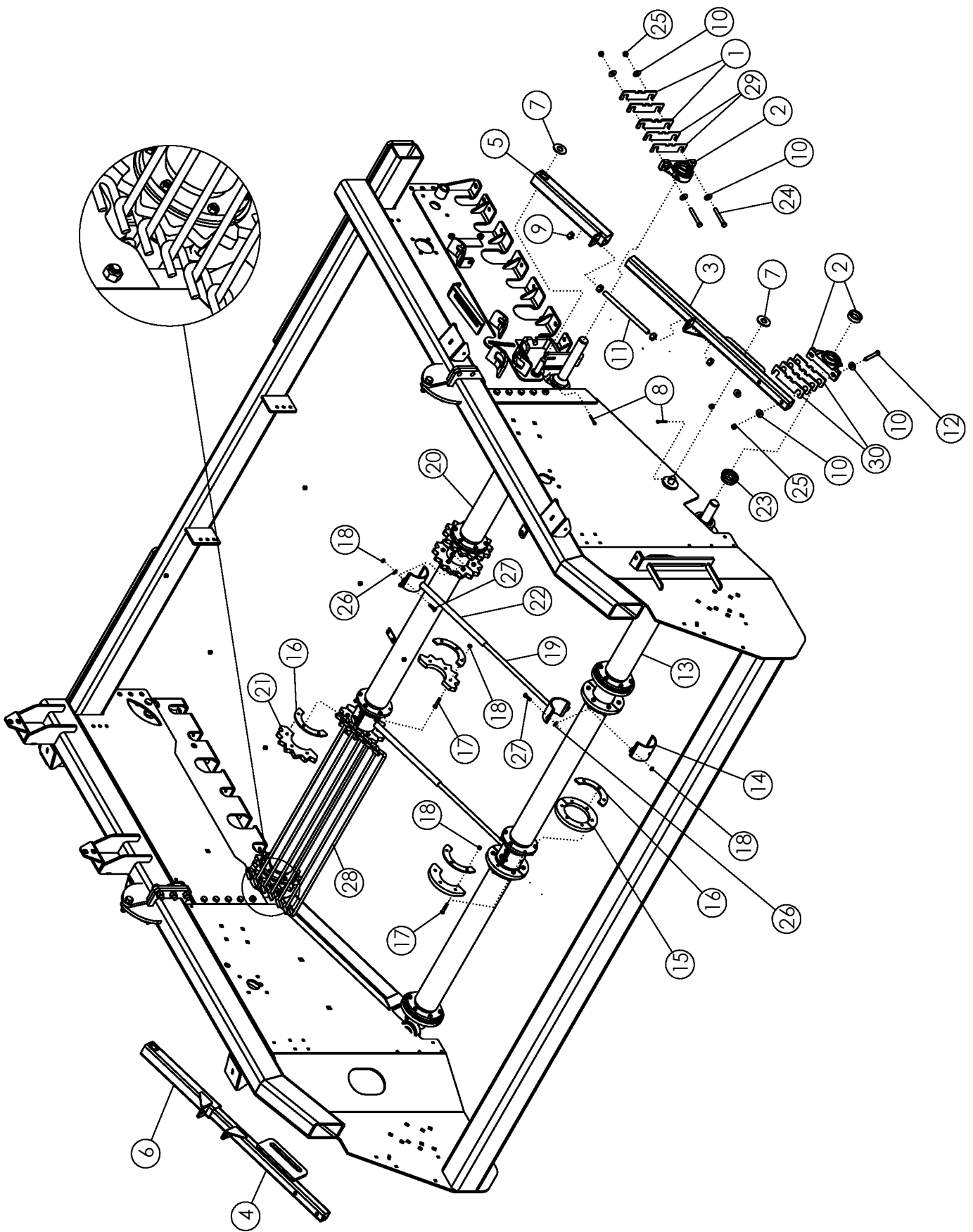

## APRON SHAFT - HOOK CHAIN

ITEM	PART NO.	DESCRIPTION	QTY
1	56672	SHIM-BEARING ZP	AR
2	52405	BEARING-PILLOW 1.75 (with lock collar)	4
3	56697	WLDMT-SLIDE LH	1
4	56698	WLDMT-SLIDE RH	1
5	56692	WLDMT-ARM LH	1
6	56693	WLDMT-ARM RH	1
7	1020685	WASHER-FLAT: 1.00 ZP	4
8	1016944	PIN-COTTER: .25 X 2.00 ZP	4
9	1011620	NUT-HEX: .75 NC GR2 ZP	8
10	1014443	WASHER-FLAT: .50 ZP	16
11	56718	ROD-THREADED ZP	2
12	1029104	BOLT-HEX: .50 X 3.75 NC GR5 ZP	4
13	63394	WLDMT- BOTTOM APRON SHAFT	1
14	64159	CLAMP-FILLER PAINTED	4
15	58322	HALF-DISC ZP	12
16	62836	HALF DISC - SPACER ZP (1/2" CHAIN ONLY)	24
17	1011725	BOLT-HEX: .38 X 2.00 NC GR5 ZP (1/2" CHAIN ONLY)	72
	1011603	BOLT-HEX: .38 X 1.75 NC GR5 ZP	
18	1016999	NUT-TOPLOCK: .38 NC GR5 ZP	80
19	64161	WLDMT-LOWER FILLER	2
20	63352	WLDMT-TOP APRON SHAFT	1
21	58318	SPROCKET-HALF 2.38 ZP	12
	64154	SPROCKET-HALF 2.38 ZP (ROCK)	
22	64162	WLDMT-UPPER FILLER	2
23	52382	SEAL PROTECTOR 1-3/4"	2
24	1032507	BOLT-HEX: .50 X 4.00 NC GR5 ZP	4
25	1027461	NUT-TOPLOCK: .50 NC GR5 ZP	8
26	1011828	WASHER-FLAT: .38 ZP	8
27	64991	BOLT-HEX: .38 X 1.25 NC GR8 ZP	8
28	53844	CHAIN 1/2 X 42 X 2.38	6
	53846	CHAIN 5/8 X 42 X 2.38	
29	300146	SHIM-BEARING .120 THICK	4
30	56772	SHIM-BEARING ZP (PLASTIC PADDLE OPTION)	8

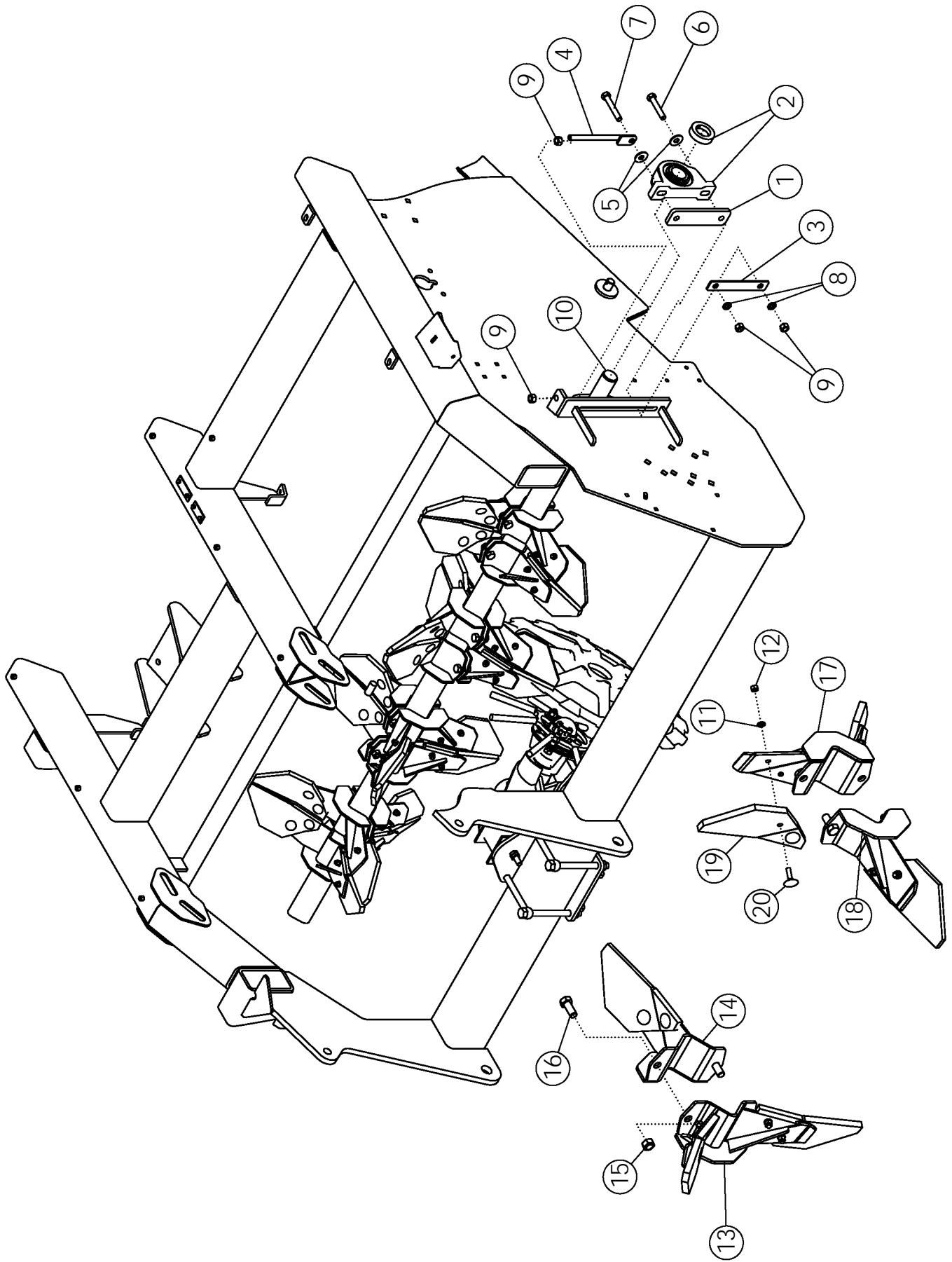



# PADDLE SHAFT

ITEM	PART NO.	DESCRIPTION	QTY
1	57996	SHIM-BEARING ZP	2
2	57997	BEARING-PILLOW 2"	2
3	57998	PLATE-BACKING ZP	2
4	51365	TIGHTENER BOLT	2
5	1013024	WASHER-FLAT: .63 ZP	4
6	1014000	BOLT-HEX: .63 X 3.50 NC GR5 ZP	2
7	1016726	BOLT-HEX: .63 X 4.00 NC GR5 ZP	2
8	1011813	WASHER-LOCK: .63 ZP	4
9	1011578	NUT-HEX: .63 NC GR2 ZP	8
10	57975	WLDMT-PADDLE SHAFT	1
11	1011586	WASHER-LOCK: .38 ZP	72
12	1011576	NUT-HEX: .38 NC GR2 ZP	72
13	50722	WLDMT - PADDLE DOUBLE RH	6
14	50721	WLDMT - PADDLE SINGLE RH	6
15	1016595	NUT-TOPLOCK: .63 NC GR5 ZP	24
16	1014349	BOLT-HEX: .63 X 1.50 NC GR5 ZP	24
17	50719	WLDMT - PADDLE DOUBLE LH	6
18	50720	WLDMT - PADDLE SINGLE LH	6
19	51562	PADDLE-RUBBER	36
20	1030779	BOLT-ELEVATOR: .38 X 1.50 NC ZP	72

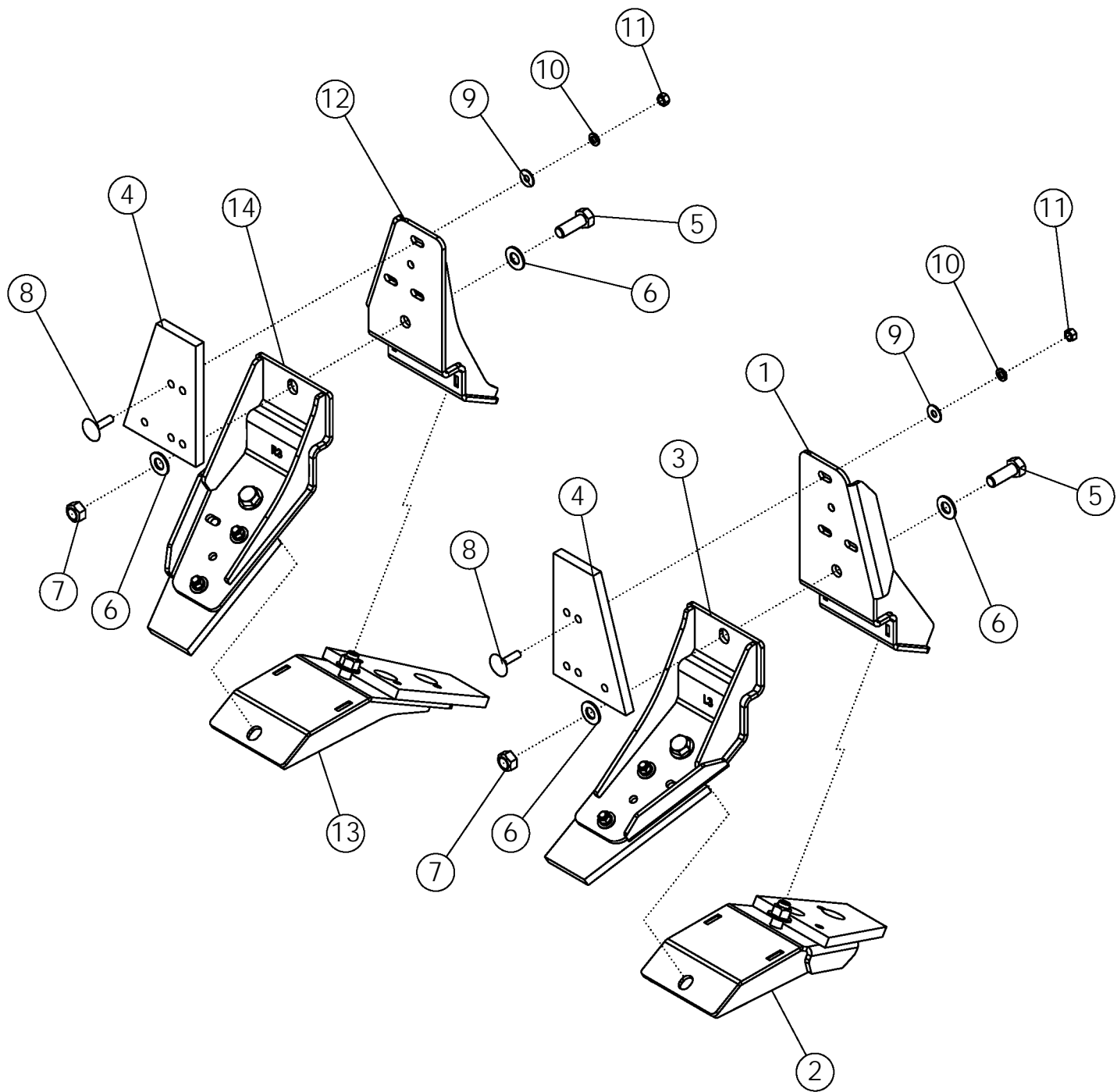

# HYBRID PADDLE ASSY

ITEM	PART NO.	DESCRIPTION	QTY
1	301863	WLDMT-PADDLE SPLIT LH 1	1
2	301867	WLDMT-PADDLE SPLIT LH 2	1
3	301871	WLDMT-PADDLE SPLIT LH 3	1
4	301875	PADDLE-RUBBER SOLID	6
5	1013918	BOLT-HEX .63 X 1.750 NC GR5 ZP	6
6	1013004	WASHER-FLAT: SAE .63 ZP	12
7	1016595	NUT-TOPLOCK: .63 NC GR5 ZP	6
8	1030779	BOLT-ELEVATOR:.38 X 1.50 NC ZP	18
9	1011828	WASHER-FLAT .38 ZP	18
10	1011586	WASHER-LOCK: .38 ZP	18
11	1011576	NUT-HEX: .38 NC GR2 ZP	18
12	301865	WLDMT-PADDLE SPLIT RH 1	1
13	301869	WLDMT-PADDLE SPLIT RH 2	1
14	301873	WLDMT-PADDLE SPLIT RH 3	1

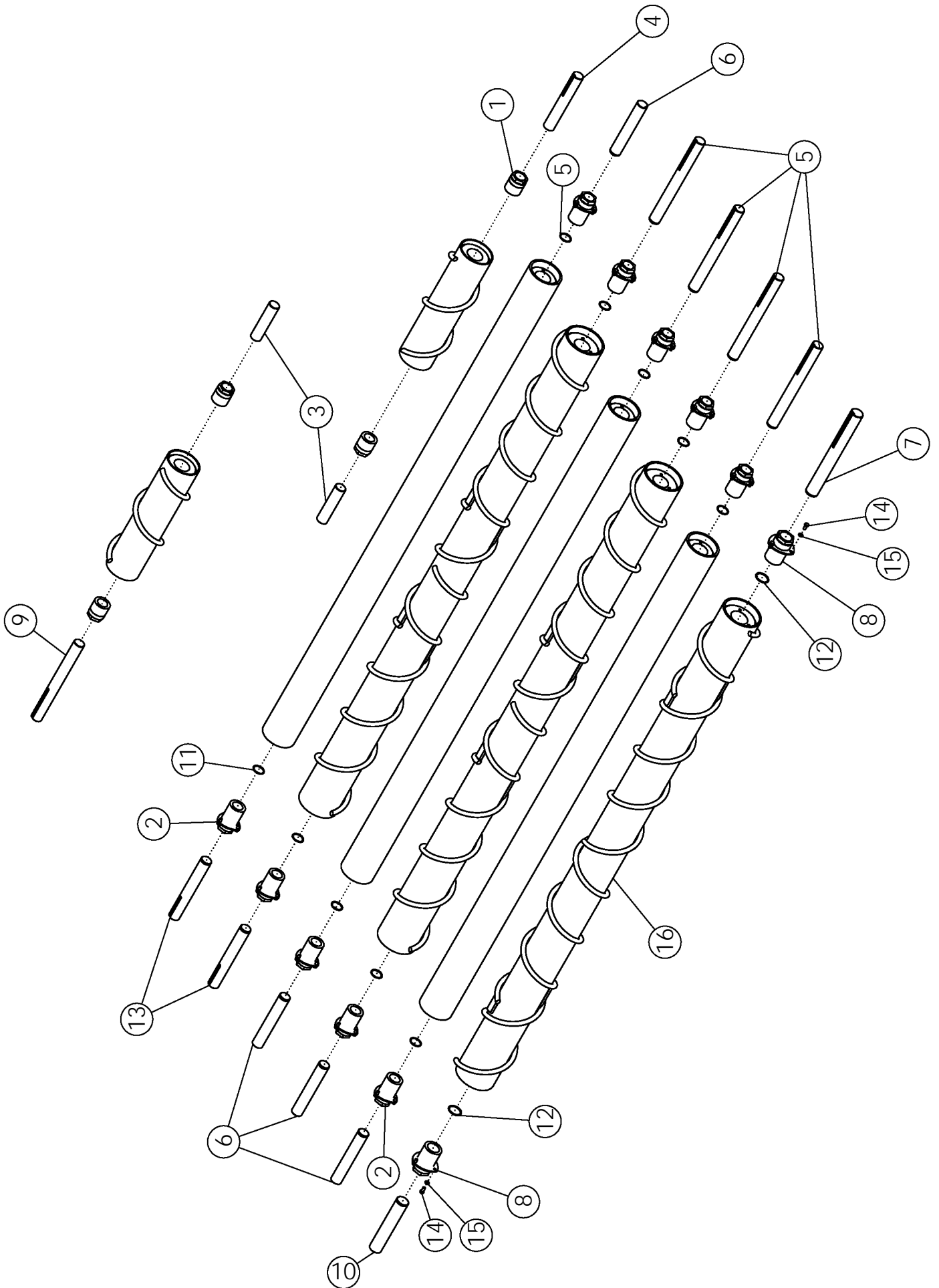

# CLEANING ROLLS

ITEM	PART NO.	DESCRIPTION	QTY
------	----------	-------------	-----

## PARTS COMMON TO ALL ROLLS

1	58459	HUB-TRANTORQUE 1.75	4
2	64163	HUB-TRANTORQUE 1.75 X 3.38	10
3	59471	SHAFT-STUB-#7 ROLL-RH, LH-IDLER	2
4	58759	SHAFT- #2, 3, 4, 5, 7LH	1
5	64177	SHAFT-DRIVE #2,3,4,5	4
6	64179	SHAFT-IDLER #2,3,4,6	4
7	64181	SHAFT-#1 DRIVE END	1
8	64165	HUB-TRANTORQUE 2.00 X 3.38	2
9	58761	SHAFT-#7 RH ROLL-DRIVE END	1
10	64182	SHAFT-#1 IDLER END	1
11	64184	RING-RETAINING 1.75	10
12	64185	RING-RETAINING 2.00	2
13	64178	SHAFT-#5,6	2
14	1011599	BOLT-HEX: .38 X .75 NC GR5 ZP	36
15	1011586	WASHER-LOCK: .38 ZP	36

## NUMBER ONE ROLL (COMPLETE)

16	58824	WLDMT-#1 SCROLLED-6R-STD-TT	1
	58937	WLDMT-#1 SCROLLED-6R-POLY-TT	
	58948	WLDMT-#1-SCROLLED-6R-HRD-TT	

## NUMBER TWO AND FOUR ROLL (COMPLETE)

17	58953	ASSY-#2,4-6R-5" STD-TT	2
	58943	ASSY-#2,4-6R-5" POLY-TT	

## NUMBER THREE ROLL (COMPLETE)

18	58829	WLDMT-#3 SCROLLED-6R-STD-TT	1
	58939	WLDMT-#3 SCROLLED-6R-POLY-TT	
	58949	WLDMT-#3-SCROLLED-6R-HRD-TT	

CONTINUED

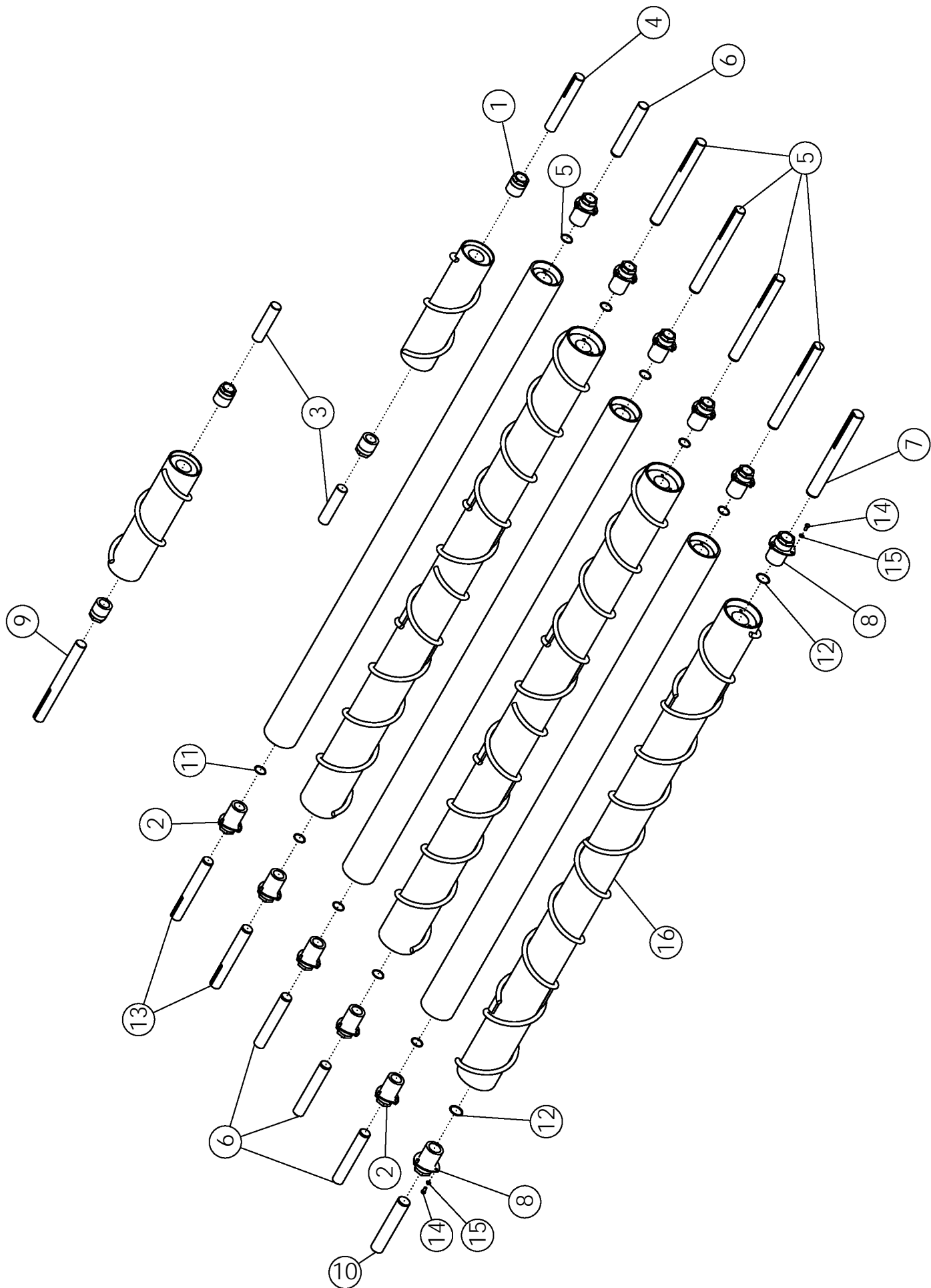

# CLEANING ROLLS (CONTINUED)

ITEM	PART NO.	DESCRIPTION	QTY
<b><u>NUMBER FIVE ROLL (COMPLETE)</u></b>			
19	302727	WLDMT-#5 SCROLLED-6R22-STD-TT	1
	302758	WLDMT-#5 SCROLLED-6R22-POLY-TT	
	302759	WLDMT-#5 SCROLLED-6R22-HRD-TT	
<b><u>NUMBER SIX ROLL (COMPLETE)</u></b>			
20	58954	ASSY-#6-6R-5.5" STD-TT	1
	58944	ASSY-#6-6R-5" POLY-TT	
<b><u>NUMBER SEVEN ROLL - - LEFT HAND (COMPLETE)</u></b>			
21	302723	WLDMT-#7LH SCROLL-6R22-POLY-SHORTER	1
	302697	WLDMT-#7LH SCROLL-6R22-TT-SHORTER	
<b><u>NUMBER SEVEN ROLL - - RIGHT HAND (COMPLETE)</u></b>			
22	302722	WLDMT-#7RH SCROLL-6R22-POLY-SHORTER	1
	302696	WLDMT-#7RH SCROLL-6R22-TT-SHORTER	

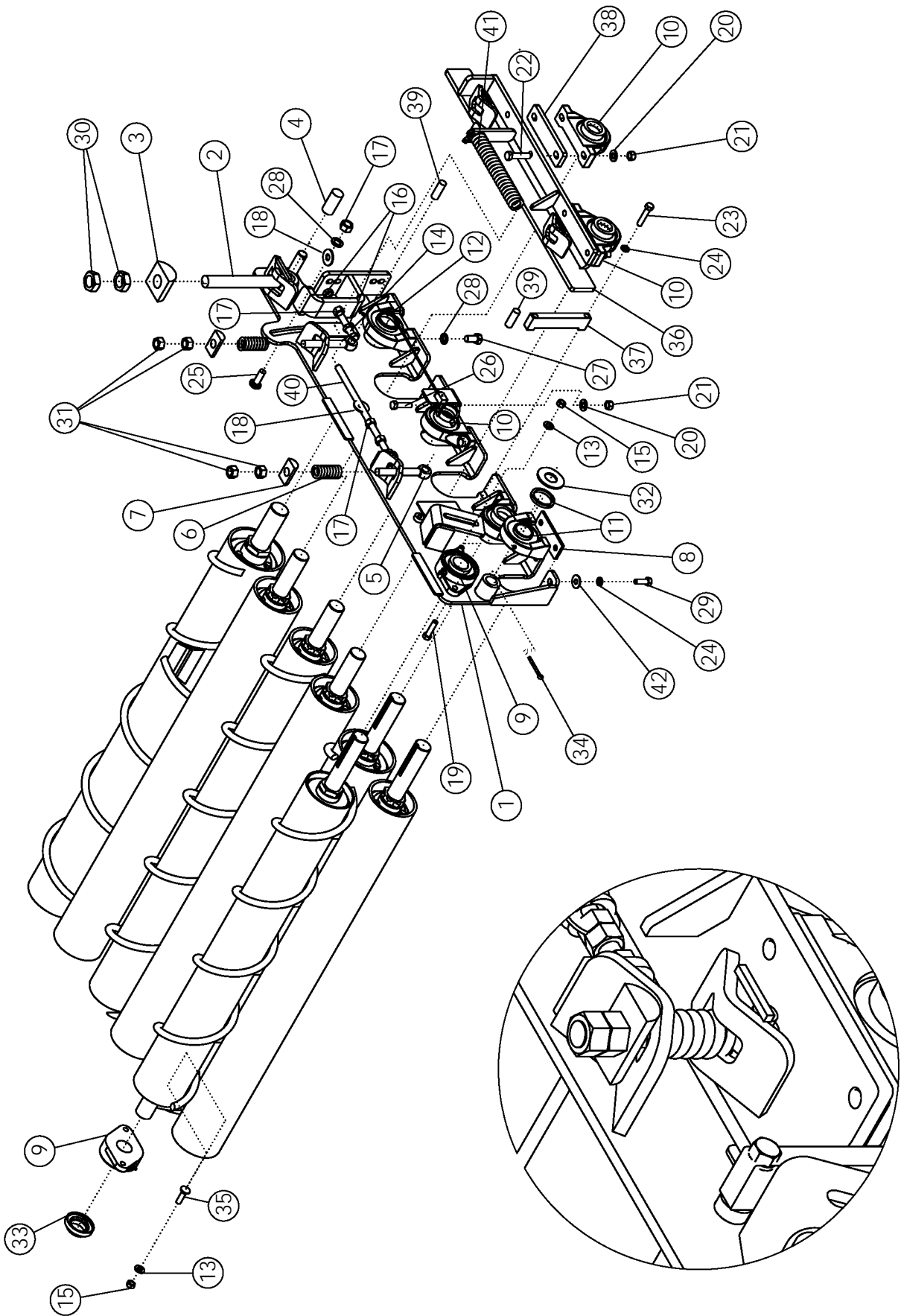



# CLEANING ROLL MOUNTING PACKAGE

ITEM	PART NO.	DESCRIPTION	QTY
1	58907	WLDMT-MOUNT RH	1
	58906	WLDMT-MOUNT LH (NOT SHOWN)	1
2	56813	BOLT-EYEBOLT: 1.25 X 10.5 ZP	2
3	56679	HALF ROUND 3.0" ZP	2
4	56676	ROD ZP	2
5	56814	BOLT-EYEBOLT: .75 X 6.00 ZP	4
6	57877	SPRING 3.00" (RIGHT SIDE ONLY)	2
7	56680	HALF ROUND 1.50" ZP	4
8	57992	SHIM-BEARING	2
9	62134	BEARING-FLANGE 1-3/4"	4
10	52405	BEARING-PILLOW 1-3/4"	8
	64466	PILLOW BLOCK BEARING 1-3/4" STL (ROCK ONLY)	
11	62135	BEARING 1.750 TAPPED BASE	2
	301608	ASSY-STEEL TAPPED BASE BRG 1-3/4"(ROCK ONLY)	
12	62136	BEARING 2.000 TAPPED BASE	2
	305523	ASSY-STL TAPPED BASE BRG 2.00" (ROCK ONLY)	
13	1011584	WASHER-FLAT: SAE .50 ZP	4
14	1032273	BOLT-TAP: .63 X 3.50 NC GR5 ZP	2
15	1027461	NUT-TOPLOCK: .50 NC GR5 ZP	8
16	1026259	NUT-JAM: .63 NC GR2 ZP	4
17	1011578	NUT-HEX: .63 NC GR2 ZP	8
18	1013024	WASHER-FLAT: .63 ZP	4
19	1011609	BOLT-HEX: .50 X 2.00 NC GR5 ZP	4
20	59104	WASHER-FLAT: .56 GR8 ZP	16
21	59105	NUT-TOPLOCK: .56 NC GR8 ZP	16
22	59103	BOLT-HEX: .56 X 2.50 NC GR8 ZP	8
23	1011610	BOLT-HEX: .50 X 2.50 NC GR5 ZP	4
24	1011581	WASHER-LOCK: .50 ZP	8
25	58635	BOLT-CRG: .63 X 2.00 NC GR5 ZP	2
26	59102	BOLT-HEX: .56 X 2.00 NC GR8 ZP	8
27	1032509	BOLT-HEX: .63 X 1.25 NC GR5 ZP	4
28	1011813	WASHER-LOCK: .63 ZP	6
29	1011607	BOLT-HEX: .50 X 1.50 NC GR5 ZP	4
30	62511	NUT-JAM: 1.25 NC GR2 ZP	4
31	1011620	NUT-HEX: .75 NC GR2 ZP	8
32	1013431	WASHER-FLAT: 1.25 ZP	2
33	52383	LOCK PROTECTOR 1-3/4"	2
34	1016727	PIN-COTTER: .25 X 2.50 NP	2
35	59517	BOLT-CRG: .50 X 1.75 NC GR5 ZP	4
36	56682	WLDMT-SLIDE MOUNT RH	1
	56681	WLDMT-SLIDE MOUNT LH (NOT SHOWN)	1
37	56677	WLDMT-HOLDER	2
38	57792	SHIM-BEARING	4
39	56675	ROD ZP	4
40	56815	WLDMT-BOLT & NUT ZP	2
41	57878	SPRING 10"	2
42	1014443	WASHER-FLAT: .50 ZP	4

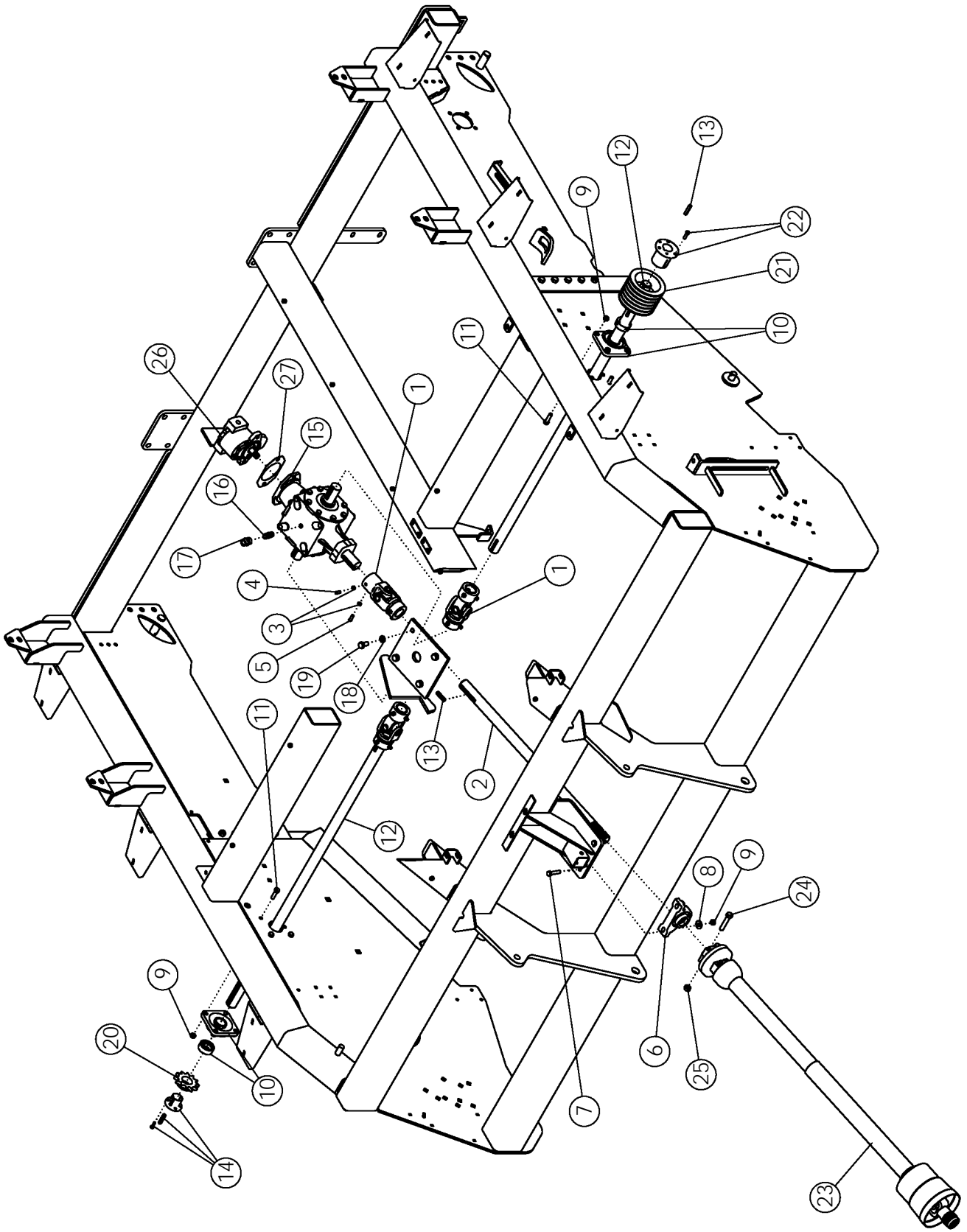

# MAIN DRIVE: ONBOARD OPTION

ITEM	PART NO.	DESCRIPTION	QTY
1	53642	U-JOINT	3
2	56775	SPLINE SHAFT	1
3	1013519	NUT-JAM: .38 NC GR2 ZP	12
4	1030708	SCREW-SET: C-P .38 X .75 NC GR8	6
5	1030709	SCREW-SET: C-P .38 X 1.00 NC GR8	6
6	52405	BEARING-PILLOW 1.75	1
7	1017708	BOLT-HEX: .50 X 2.25 NC GR5 ZP	2
8	1014443	WASHER-FLAT: .50 ZP	2
9	1027461	NUT-TOPLOCK: .50 NC GR5 ZP	10
10	52404	BEARING-FLANGE 1.75	2
11	1011608	BOLT-HEX: .50 X 1.75 NC GR5 ZP	8
12	56819	SHAFT-DRIVE 6R	2
13	50152	KEY .38 X .38 X 2.00	10
14	53641	HUB P1 1-3/4" (WITH KEY)	1
15	62396	GEARBOX-PRAIRIE (1.81:1) PAINTED	1
	63846	GEARBOX-PRAIRIE (1.81:1) 905 (BLACK)	
16	69128	FTG-ADAPTER: 8MP-8MP 4" LONG	1
17	55730	FTG-ADAPTER: 8FP-8FP	1
18	1011813	WASHER-LOCK: .63 ZP	4
19	1032509	BOLT-HEX: .63 X 1.25 NC GR5 ZP	4
20	62034	SPROCKET H80-P12	1
21	56646	SHEAVE 6TB62	1
	56647	SHEAVE 6TB68	
	53668	SHEAVE 6TB56	
22	50335	HUB Q1 1.75	1
23	301558	PTO-CV 1.75"-20 X 90" WEASLER (HRV)	1
	301575	PTO-CV 1.38"-21 X 90" WEASLER (HRV)	
24	1030704	BOLT-HEX: .63 X 3.25 NC GR5 ZP	2
25	1016595	NUT-TOPLOCK: .63 NC GR5 ZP	2
26	62153	PUMP-HYDRAULIC 5.3	1
	59761	SEAL KIT FOR 62153	
27	63702	PLATE-ADAPTER SAE 'B' PUMP	1

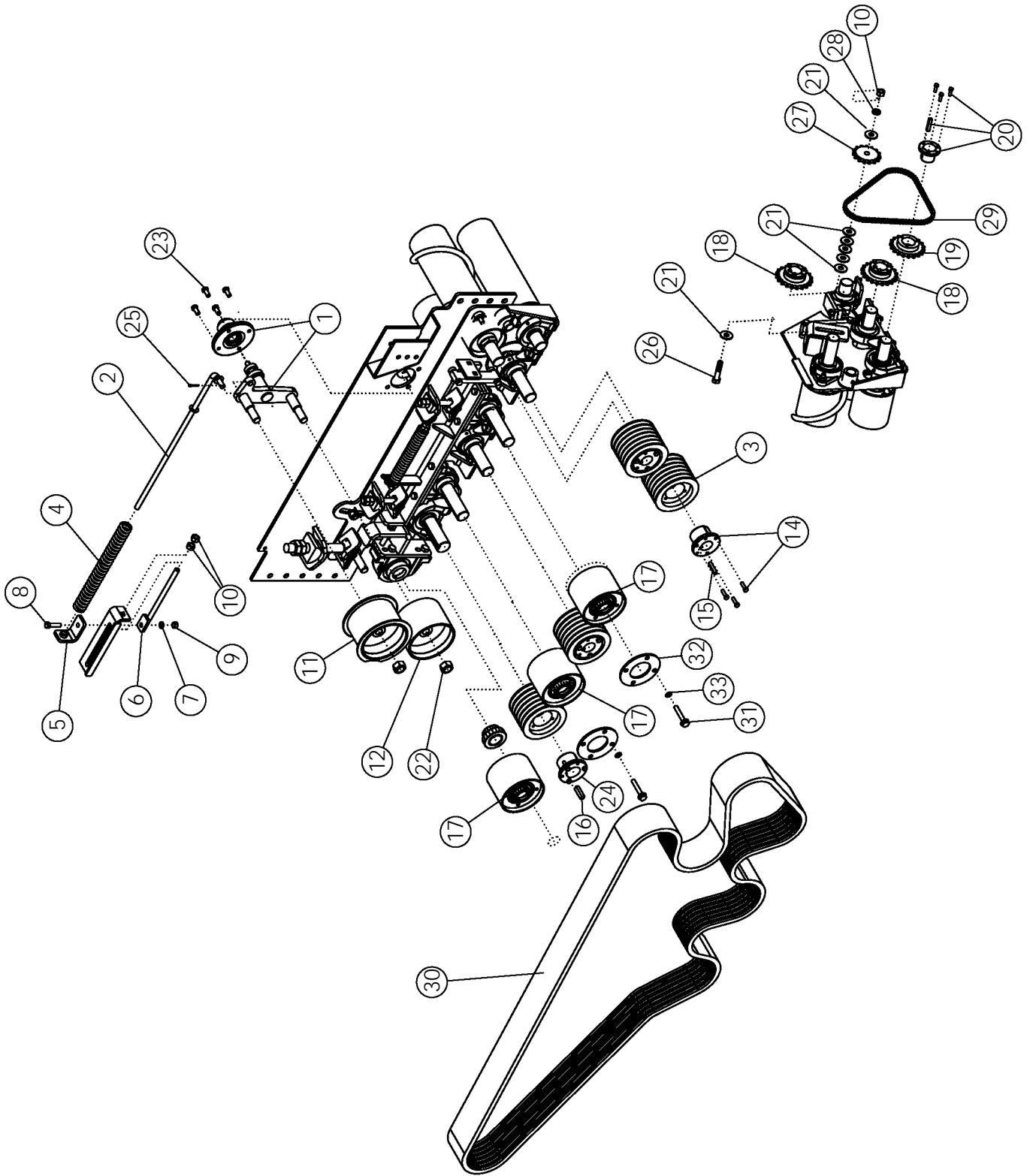

# CLEANING ROLL DRIVE

ITEM	PART NO.	DESCRIPTION	QTY
1	56422	ASSY-SPINDLE & HUB	1
2	56711	ROD-PLATED	1
3	56646	SHEAVE 6TB62	4
4	56853	SPRING	1
5	56708	HOLDER-PLATED	1
6	56707	ADJUSTMENT ROD ZP	1
7	1011581	WASHER-LOCK: .50 ZP	1
8	1011609	BOLT-HEX: .50 X 2.00 NC GR5 ZP	1
9	1011577	NUT-HEX: .50 NC GR2 ZP	1
10	1011578	NUT-HEX: .63 NC GR2 ZP	4
11	57933	WLDMT- IDLER (with flange)	1
12	50387	WLDMT-IDLER	1
13	56396	WLDMT-PULLEY 6R	2
14	50335	HUB Q1 1.75	5
15	50152	KEY .38 X .38 X 2.00	5
16	57995	KEY .50 X .50 X 2.00	1
17	301821	ASSY-REVERSE PULLEY 6R W/LOCK COLLAR	3
18	53649	SPROCKET H60-P20	2
19	62106	SPROCKET H60-P19	1
20	53641	HUB P1 1.75 (WITH KEY)	3
21	1013024	WASHER-FLAT: .63 ZP	7
22	1016969	NUT-TOPLOCK: 1.00 NC GR5 ZP	2
23	1015558	BOLT-HEX: .50 X 1.00 NF GR5 ZP	4
24	50385	HUB Q1 2.00	1
25	1019827	PIN-COTTER: .19 X 1.00 NP	1
26	1011624	BOLT-HEX: .63 X 3.00 NC GR5 ZP	1
27	53651	7348-2 SPROCKET IDLER	1
28	1011813	WASHER-LOCK: .63 ZP	1
29	58165	CHAIN-ROLLER 60H-1R-052	1
30	56648	V-BELT 6B195	1
31	301936	BOLT-FLG: .50 X 2.50 NC GR5 ZP	8
32	301718	PLATE-REVERSE GRABROLL COVER	2
33	301937	WASHER-STAR: .50 ZP	8

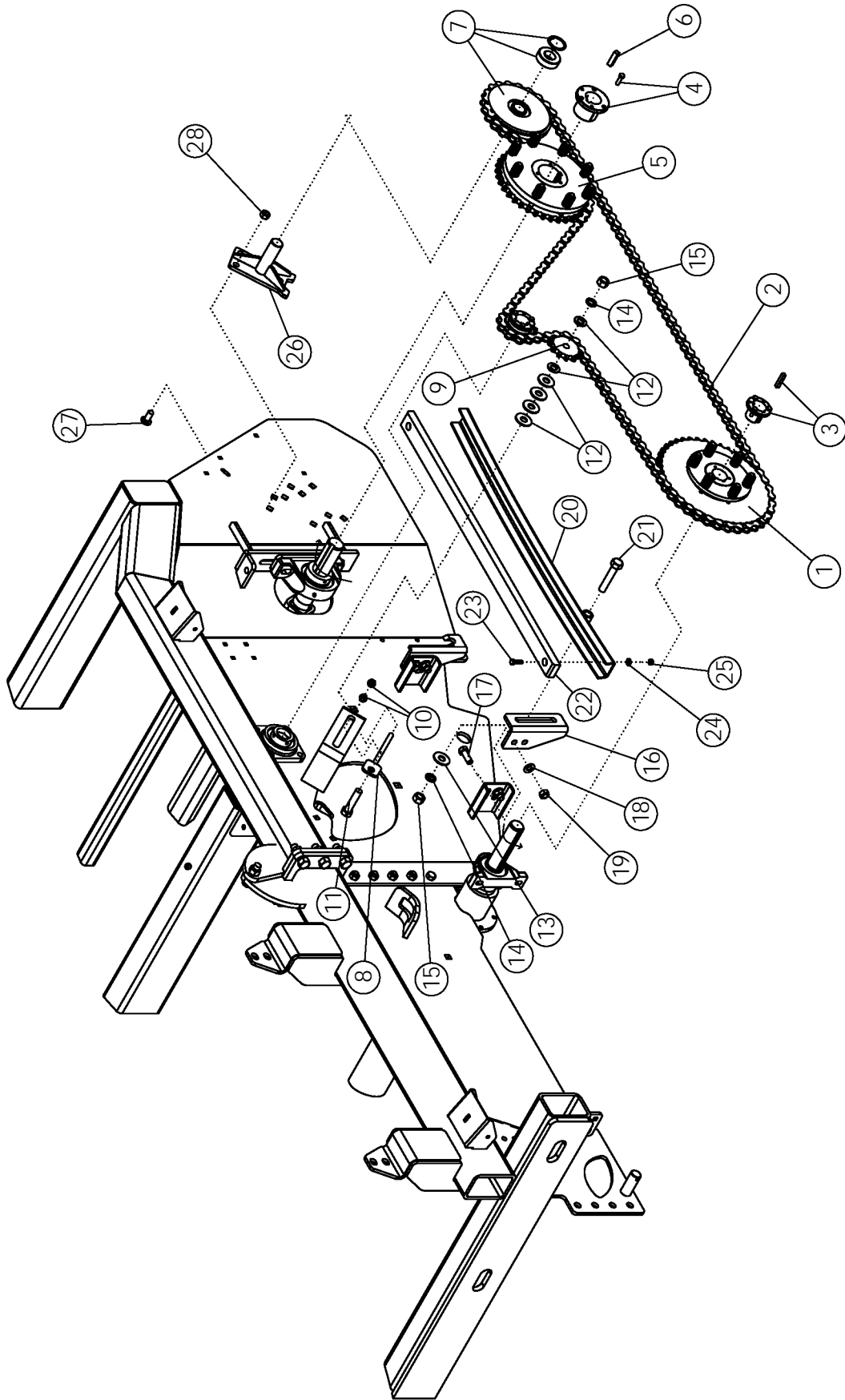

# APRON/PADDLE SHAFT DRIVE

ITEM	PART NO.		QTY
1	58335	SPROCKET-CLUTCH 80P45 PRESET	1
	73034	SPROCKET H80-P14 (ROCK ONLY)	
2	63578	CHAIN-ROLLER 80H-1R-176	1
	69412	CHAIN-ROLLER 80H-1R-182 (PLASTIC PADDLE)	
3	53641	HUB P1 1.75 (WITH .38 X 2.00 KEY)	1
4	50385	HUB Q1 2.00	1
5	57993	SPROCKET-CLUTCH 80Q36 PRESET	1
	69630	SPROCKET-CLUTCH 80Q51 PRESET (PLASTIC PADDLE)	
6	57995	KEY .50 X .50 X 2.00	1
7	56851	SPROCKET-IDLER H8025 X 1.44	1
8	56864	WLDMT-ADJUSTER	1
9	56334	SPROCKET-IDLER 8012	1
10	1011577	NUT-HEX: .50 NC GR2 ZP	2
11	1032271	BOLT-HEX: .75 X 3.25 NC GR5 ZP	1
12	1012634	WASHER-FLAT: SAE .75 ZP	6
13	1030702	WASHER-FLAT: .75 ZP	2
14	1012061	WASHER-LOCK: .75 ZP	3
15	1011620	NUT-HEX: .75 NC GR5 ZP	3
16	57804	MOUNT	2
17	1013918	BOLT-HEX: .63 X 1.75 NC GR5 ZP	4
18	1013004	WASHER-FLAT: SAE .63 ZP	4
19	1016595	NUT-TOPLOCK: .63 NC GR5 ZP	4
20	57853	WLDMT-SUPPORT	1
21	1011625	BOLT-HEX: .75 X 4.00 NC GR5 ZP	2
22	57827	SLIDE-CHAIN	1
23	1011601	BOLT-HEX: .38 X 1.25 NC GR5 ZP	2
24	1014608	WASHER-FLAT: SAE .38 ZP	2
25	1016999	NUT-TOPLOCK: .38 NC GR5 ZP	2
26	69625	WLDMT-IDLER PADDLE SHAFT	1
27	72063	BOLT-CRG: .63 X 1.50 NC GR5 ZP	3
28	1016595	NUT-TOPLOCK: .63 NC GR5 ZP	3
29	68136	PLUG- .625 SQUARE PLASTIC (NOT SHOWN)	4

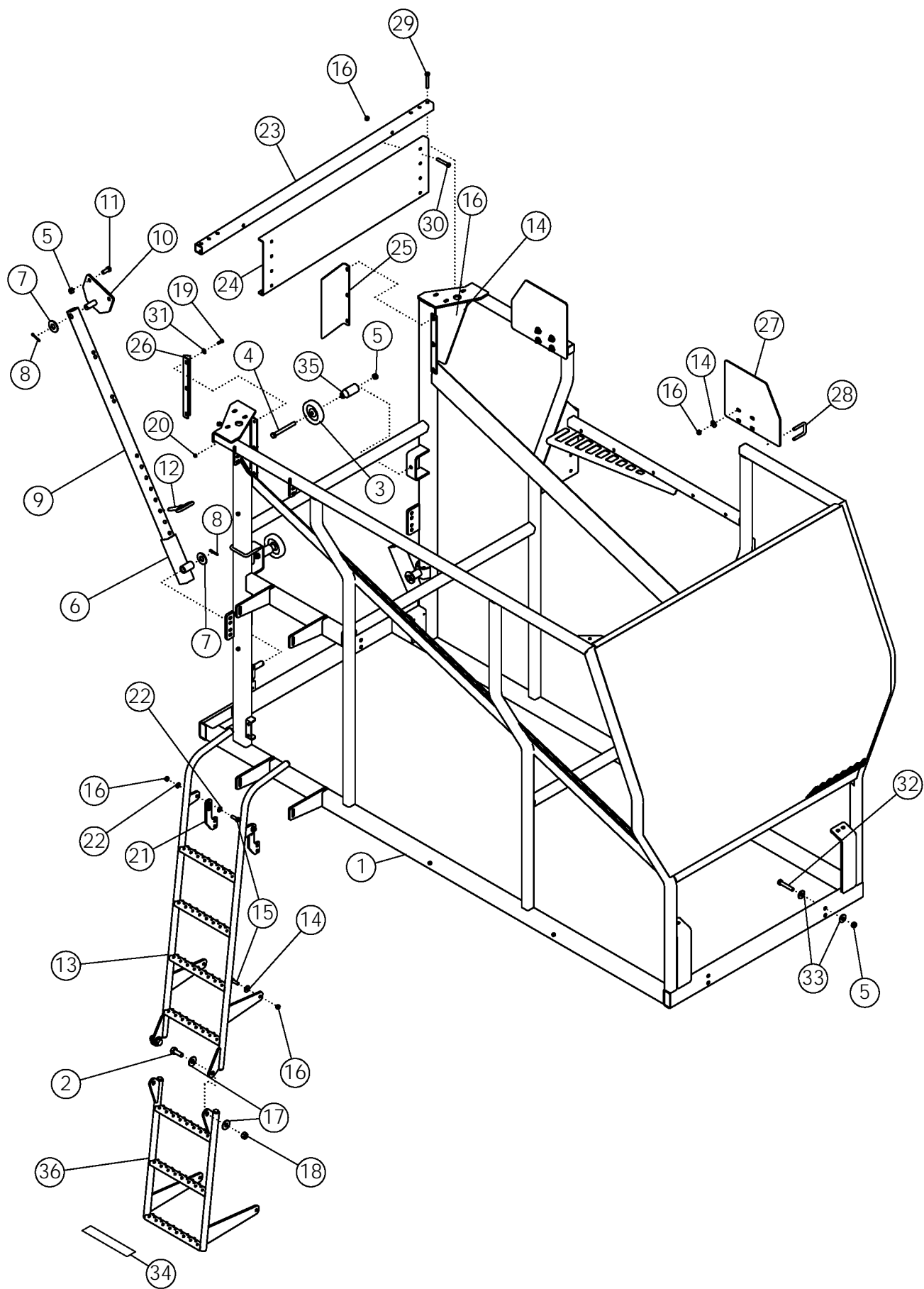



# TANK

ITEM	PART NO.	DESCRIPTION	QTY
1	69797	WLDMT-TANK WHEEL 6R	1
2	1012060	BOLT-HEX: .75 X 2.00 GR5 ZP	2
3	53825	BOGIE WHEEL 5"	2
4	1013068	BOLT-HEX: .63 X 6.00 NC GR5 ZP	2
5	1016595	NUT-TOPLOCK: .63 NC GR5 ZP	14
6	54788	WLDMT-LOCK SLIDE	2
7	1020685	WASHER-FLAT: 1.00	4
8	1016944	PIN-COTTER: .25 X 2.00 ZP	4
9	56836	TUBE-LOCK	2
10	54785	WLDMT-LOCK BRACKET	2
11	1014349	BOLT-HEX: .63 X 1.50 NC GR5 ZP	4
12	1030947	PIN-HITCH: .63 X 4.00 ZP W/HAIRPIN	2
13	72420	WLDMT-LADDER TOP	1
14	1014443	WASHER-FLAT: .50 ZP	18
15	1011607	BOLT-HEX: .50 X 1.50 NC GR5 ZP	10
16	1027461	NUT-TOPLOCK: .50 NC GR5 ZP	24
17	1030702	WASHER-FLAT: .75 ZP	4
18	1017000	NUT-TOPLOCK: .75 NC GR5 ZP	2
19	1011600	BOLT-HEX: .38 X 1.00 NC GR5 ZP	6
20	1016999	NUT-TOPLOCK: .38 NC GR5 ZP	6
21	301382	PLATE-LADDER MOUNT NARROW	2
22	1011584	WASHER-FLAT: SAE .50 ZP	4
23	64749	TUBE-STRIKER	1
24	64574	PLATE-STRIKER	1
25	64746	PLATE-TANK TO BOOM REAR	1
26	64747	PLATE-TANK TO BOOM FRONT	1
27	57917	PLATE-EXTENSION	2
28	65658	U-BOLT: .50 X 3 X 2.06 X 3	4
29	1017719	BOLT-HEX: .50 X 3.25 NC GR5 ZP	4
30	1011611	BOLT-HEX: .50 X 3.00 NC GR5 ZP	2
31	1011828	WASHER-FLAT: .38 ZP	6
32	1014000	BOLT-HEX: .63 X 3.50 NC GR5 ZP	8
33	1013024	WASHER-FLAT: .63 ZP	16
34	59615	DECAL-REFLECTIVE TAPE	7
35	64192	STAND-OFF 4.00	2
36	301320	WLDMT-LADDER BOTTOM 3-RUNG	1

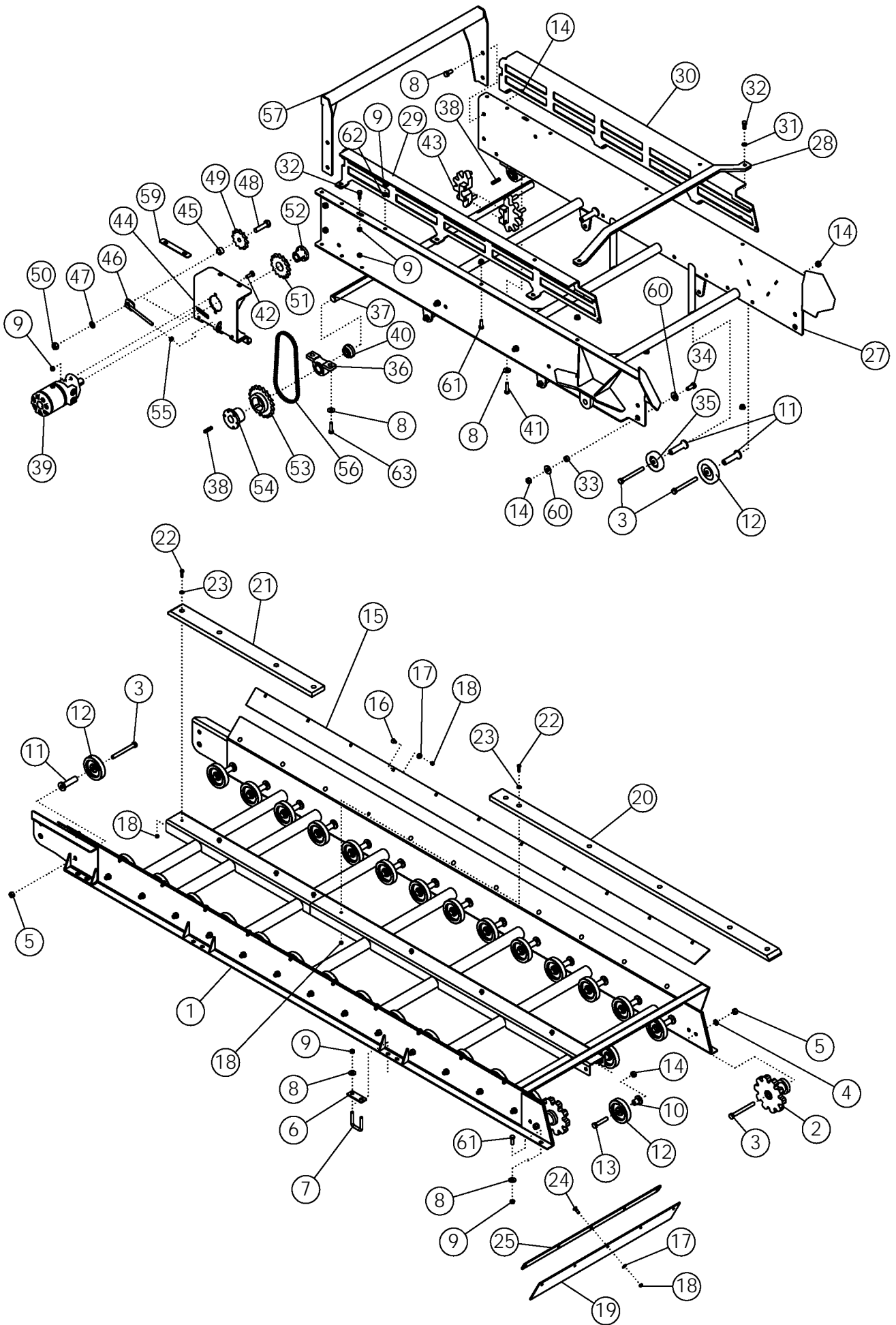

# ELEVATOR AND BOOM ASSEMBLY

ITEM	PART NO.	DESCRIPTION	QTY
1	301510	WLDMT-ELEVATOR 6R	1
2	63813	SPROCKET-IDLER 50MM 10T	2
	54824	SPROCKET-IDLER 56MM	
3	1013068	BOLT-HEX: .63 X 6.00 NC GR5 ZP	40
4	1011813	WASHER-LOCK: .63 ZP	2
5	1011578	NUT-HEX: .63 NC GR2 ZP	2
6	64748	PLATE-ELEVATOR BACKING	4
7	65658	U-BOLT: .50 X 3 X 2.06 X 3	6
8	1014443	WASHER-FLAT: .50 ZP	25
9	1027461	NUT-TOPLOCK: .50 NC GR5 ZP	30
10	58971	STAND OFF 1.50"	2
11	64192	STAND OFF	38
12	53825	BOGIE WHEEL 5"	36
13	65825	BOLT-HEX: .63 X 3.25 NC GR5 ZP	2
14	1016595	NUT-TOPLOCK: .63 NC GR5 ZP	46
15	64550	SHEET-BELT PROTECTOR	2
16	59488	BOLT-CRG: .38 X 1.00 NC GR5 ZP	22
17	1011828	WASHER-FLAT .38 ZP	22
18	1016999	NUT-TOPLOCK: .38 NC GR5 ZP	36
19	64609	FLAP-ELEVATOR	1
20	69822	SLIDE-ELEVATOR PLASTIC 6R/8R/12R	1
21	301515	SLIDE-ELEVATOR PLASTIC 6R	1
22	1011601	BOLT-HEX: .38 X 1.25 NC GR5 ZP	9
23	1014608	WASHER-FLT: SAE .38 ZP	9
24	1016362	BOLT-CRG: .38 X 1.25 NC GR5 ZP	5
25	64608	STRIP-BOLTING	1
26	68075	BELT-50MM ELEVATOR 6R (NOT SHOWN)	1
	68074	BELT-56MM ELEVATOR 6R (NOT SHOWN)	
	301509	BELT- 56MM ELEVATOR 6R DOUBLE (NOT SHOWN)	
	301513	BELT- 50MM ELEVATOR 6R DOUBLE (NOT SHOWN)	
27	53450	WLDMT-ELEVATOR BOOM 4R/6R/8R	1
28	54803	CROSS BRACE-BOOM	1
29	301525	PLATE-BOOM EXTENSION SHORT FRONT	1
30	301524	PLATE-BOOM EXTENSION SHORT REAR	1
31	1011581	WASHER-LOCK: .50 ZP	2
32	1011606	BOLT-HEX: .50 X 1.25 NC GR5 ZP	4
33	53449	SLEEVE-HINGE	2
34	1014349	BOLT-HEX: .63 X 1.50 NC GR5 ZP	6
35	53854	BOGIE WHEEL 4"	4
36	52405	BEARING-PILLOW 1-3/4"	2

CONTINUED

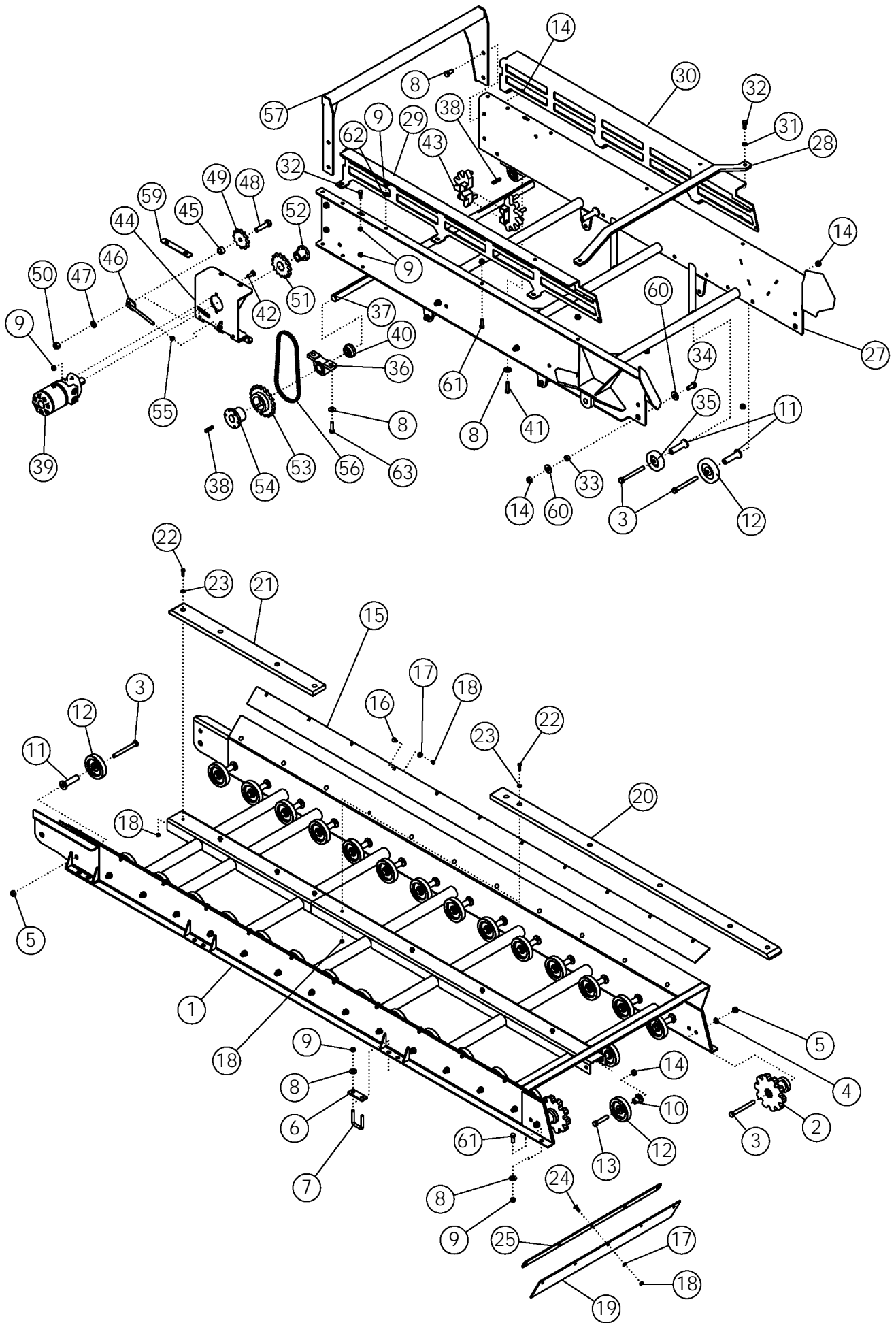

# ELEVATOR AND BOOM ASSEMBLY (CONTINUED)

ITEM	PART NO.	DESCRIPTION	QTY
37		SHAFT	1
38	50152	KEY .38 X .38 X 2.00	3
39	57686	MOTOR-HYDRAULIC 32.3IN <sup>3</sup> /REV	1
	57880	SEAL KIT FOR 57686	
40	53933	CHAIN-ROLLER 60H-1R-045	2
41	1011609	BOLT-HEX: .50 X 2.00 NC GR5 ZP	2
42	1011660	BOLT-CRG: .50 X 1.50 NC GR5 ZP	2
43	63817	SPROCKET-SPLIT 56MM	2
	301521	SPROCKET-SPLIT 50MM 12T Ø1.750 DOUBLE BELT	
	301522	SPROCKET-SPLIT 56MM 10T Ø1.750 DOUBLE BELT	
	68659	SPROCKET-SPLIT 50MM 12T Ø1.750	
44	64627	WLDMT-REDUCTION MOUNT	1
45	58086	SPACER-CHAIN IDLER ZP	1
46	63876	TENSIONER ZP	1
47	1012061	WASHER-LOCK: .75 ZP	1
48	1012059	BOLT-HEX: .75 X 3.00 NC GR5 ZP	1
49	56334	SPROCKET-IDLER 8012	1
50	1011620	NUT-HEX: .75 NC GR2 ZP	1
51	64155	SPROCKET H80-P15	1
52	53719	HUB P1 1-1/4"	1
53	56650	SPROCKET H80-Q20	1
54	50752	HUB Q1 1-7/16"	1
55	1011591	NUT-JAM: .50 NC ZP	2
56	64654	CHAIN-ROLLER 60H-1R-045	1
	64675	LINK-OFFSET #80H	2
57	64578	WLDMT-BOOM END SUPPORT	1
58	1032509	BOLT-HEX: .63 X 1.25 NC GR5 ZP	4
59	64732	PLATE-SHIM 0.120	2
60	1013024	WASHER-FLAT: .63 ZP	4
61	1011607	BOLT-HEX: .50 X 1.50 NC GR5 ZP	2
62	1011584	WASHER-FLAT: SAE .50 ZP	12
63	1017708	BOLT-HEX: .50 X 2.25 NC GR5 ZP	2

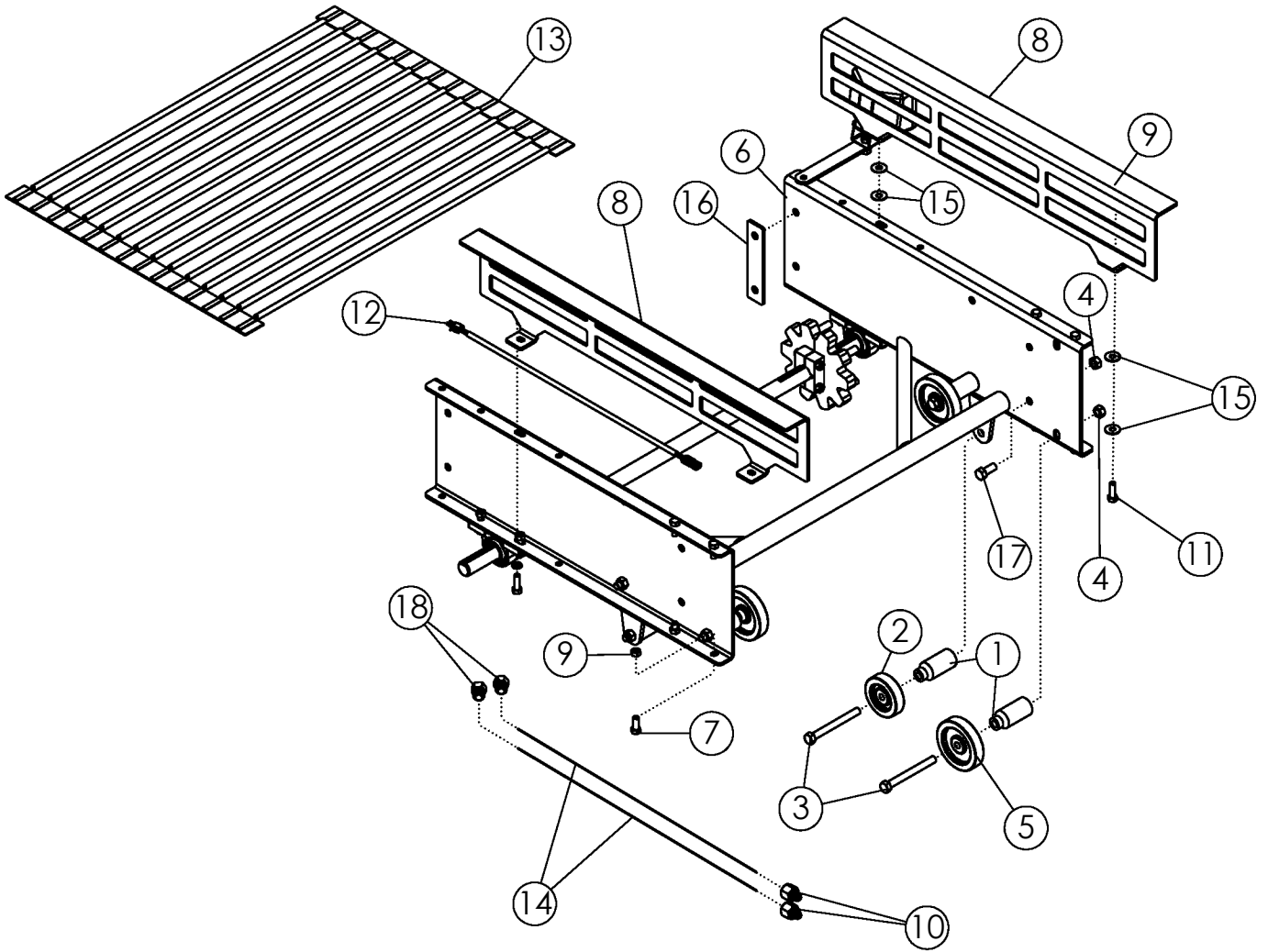

## BOOM EXTENSION 30" 50MM/56MM (OPTIONAL)

ITEM	PART NO.	DESCRIPTION	QTY
1	64192	STAND OFF	6
2	53854	BOGIE WHEEL 4"	2
3	1013068	BOLT-HEX: .63 X 6.00 NC GR5 ZP	6
4	1016595	NUT-TOPLOCK: .63 NC GR5 ZP	10
5	53825	BOGIE WHEEL 5"	4
6	68708	WLDMT-BOOM EXTENSION	1
7	1011606	BOLT-HEX: .50 X 1.25 NC GR5 ZP	8
8	302241	WLDMT-BOOM RISER EXT. RAIL	2
9	1027461	NUT-TOPLOCK: .50 NC GR5 ZP	12
10	66943	FTG-ADAPTER: 12FJ-8MJ	2
11	1011607	BOLT-HEX: .50 X 1.50 NC GR5 ZP	4
12	301717	HARNESS-EXTENSION: 32" 2 WIRE	2
13	68077	BELT-50MM: .50 X 42 X 30LPR	1
	68076	BELT-56MM: .50 X 42 X 27LPR	
	301836	BELT-56MM ELEVATOR EXT DOUBLE	
	301812	BELT-50MM ELEVATOR EXT DOUBLE	
	304003	BELT-55MM HP ELEVATOR EXT 2300-2500	
14	44165	HOSE: .75 X 030 12FJX-12MJ	2
15	1014443	WASHER-FLAT: .50 ZP	17
16	68710	PLATE-BOOM SUPPORT SPACER	2
17	1014349	BOLT-HEX: .63 X 1.50 NC GR5 ZP	4
18	304025	FTG-ADAPTER: 12MJ-8FJ	2

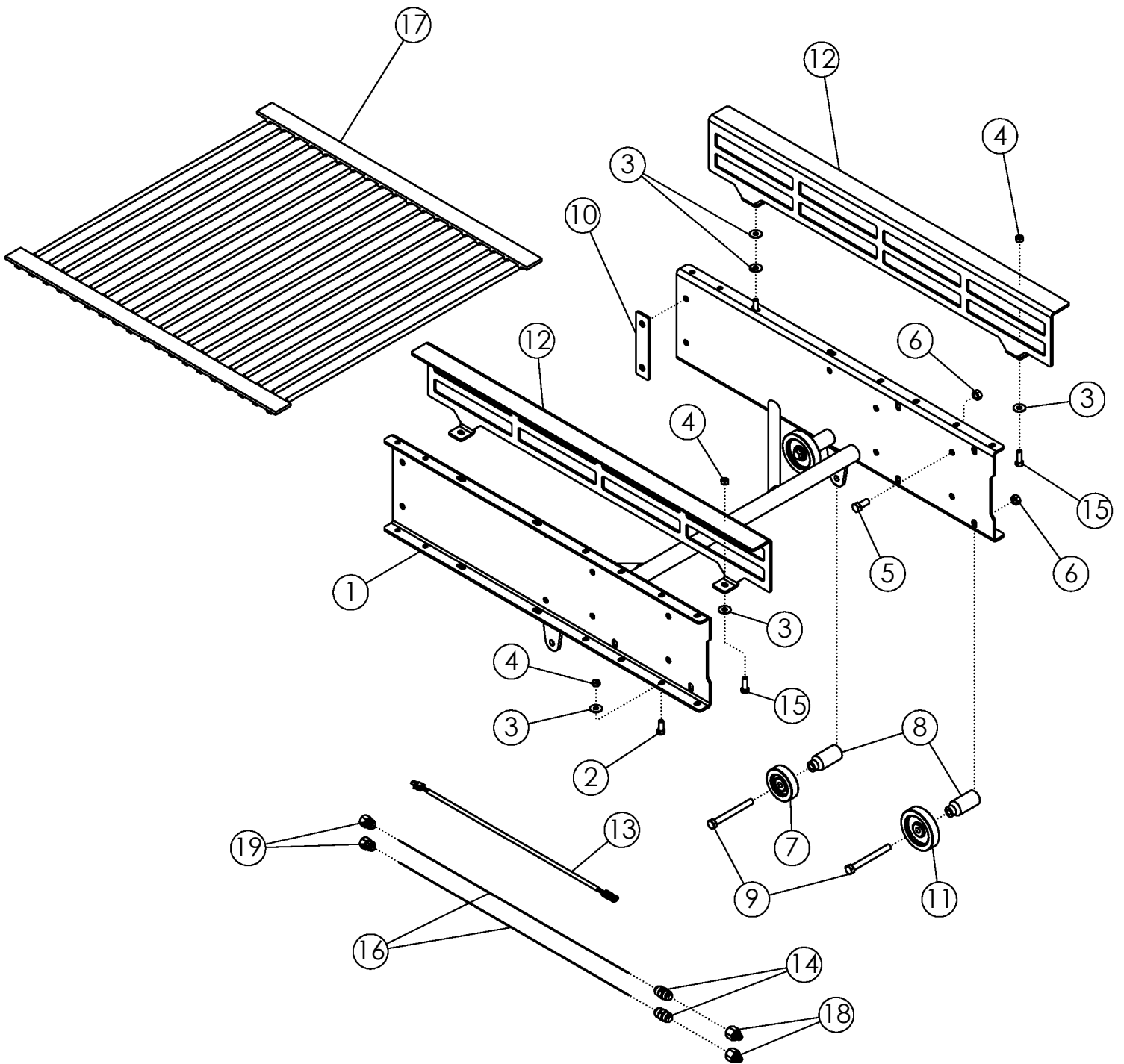



<b>BOOM EXTENSION 42" 56MM (OPTIONAL)</b>			
<b>ITEM</b>	<b>PART NO.</b>	<b>DESCRIPTION</b>	<b>QTY</b>
1	301090	WLDMT- BOOM EXTENSION Ø1.75 SHAFT LONG	1
2	1011606	BOLT-HEX: .50 X 1.25 NC GR5 ZP	8
3	1014443	WASHER-FLAT: .50 ZP	17
4	1027461	NUT-TOPLOCK: .50 NC GR5 ZP	12
5	1014349	BOLT-HEX: .63 X 1.50 NC GR5 ZP	4
6	1016595	NUT-TOPLOCK: .63 NC GR5 ZP	10
7	53854	BOGIE WHEEL 4"	2
8	64192	STAND OFF	6
9	1013068	BOLT-HEX: .63 X 6.00 NC GR5 ZP	6
10	68710	PLATE-BOOM SUPPORT SPACER	2
11	53825	BOGIE WHEEL 5"	4
12	302242	PLATE-BOOM RAILING-42" BOOM EXT	2
13	302781	HARNES-EXTENSION 44" 2 WIRE DEUTSCH	2
14	59032	FTG-ADAPTER: 12MJ-12MJ	2
15	1011607	BOLT-HEX: .50 X 1.50 NC GR5 ZP	4
16	59804	HOSE: .75 X 045 12FJX-12FJX	2
17	301106	BELT-56MM ELEVATOR EXTENSION 38 LPR	1
18	66943	FTG-ADAPTER: 12FJ-8MJ	2
19	304025	FTG-ADAPTER: 12MJ-8FJ	2

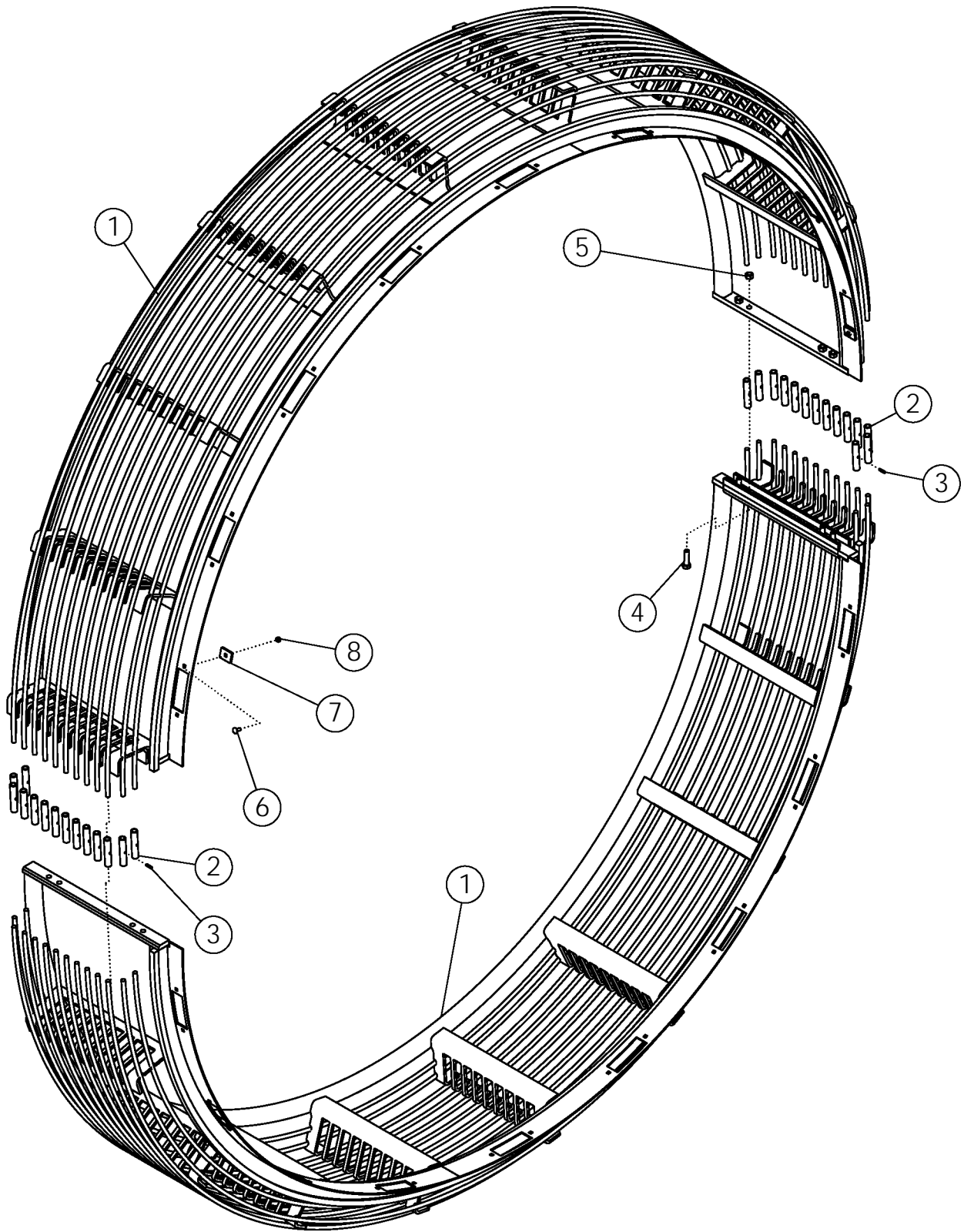

# WHEEL ASSEMBLY

ITEM	PART NO.	DESCRIPTION	QTY
1	58704	WLDMT-WHEEL HALF	2
2	59410	TUBE-COUPLER ZP	28
3	1030795	PIN-ROLL: .25 X 1.00 ZP	28
4	1017526	BOLT-HEX .63 X 2.25 NC GR5 ZP	8
5	1016595	NUT-TOPLOCK: .63 NC GR5 ZP	8
6	59488	BOLT-CRG: .38 X 1.00 NC GR5 ZP	18
7	59485	TAB-WHEEL DRIVE	18
8	1016999	NUT-TOPLOCK: .38 NC GR5 ZP	18

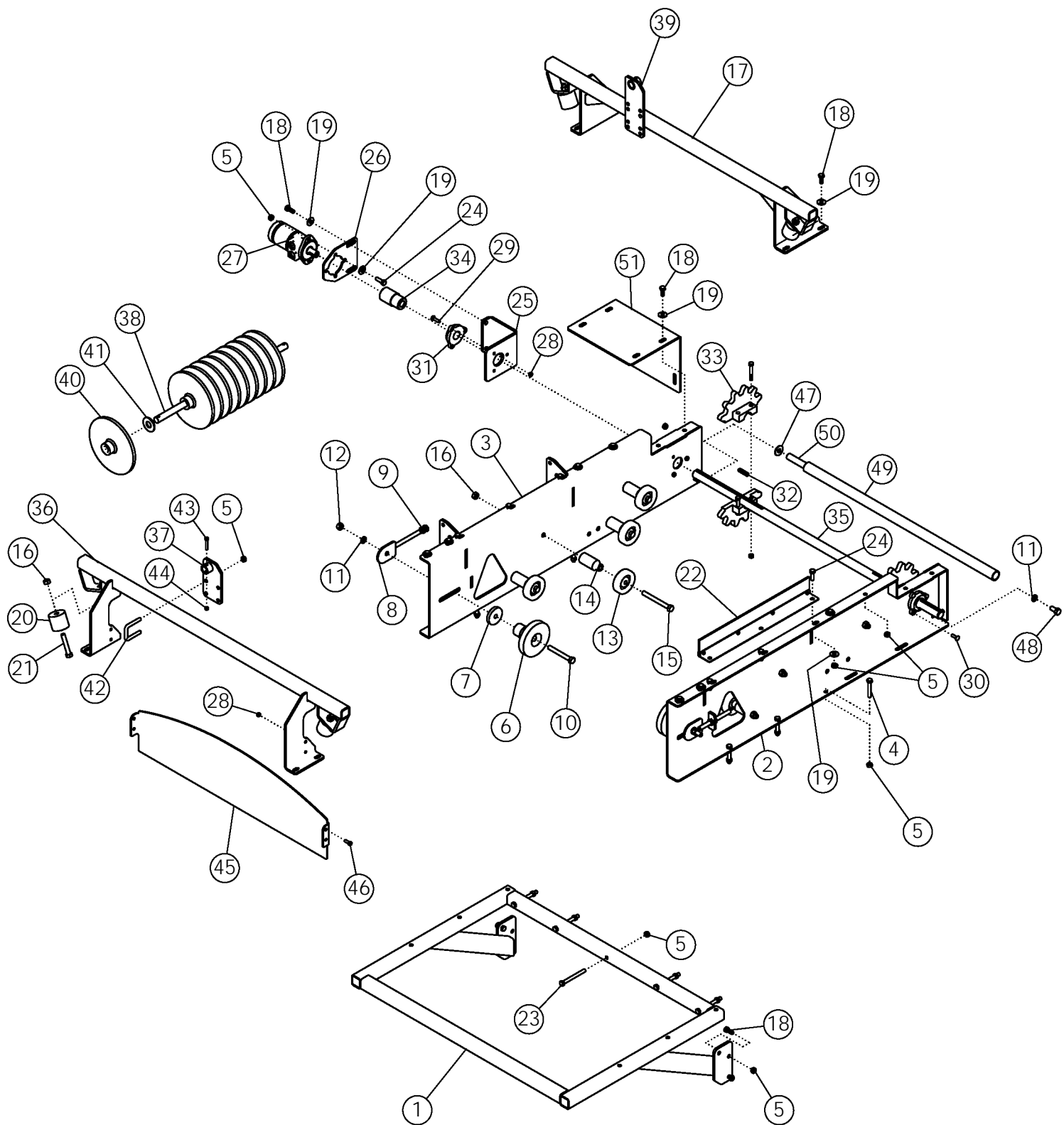

# WHEEL CONVEYOR

ITEM	PART NO.	DESCRIPTION	QTY
1	58764	WLDMT-CONVEYOR FRAME	1
2	73663	WLDMT-CONVEYOR RH	1
3	73664	WLMDT-CONVEYOR LH	1
4	1011611	BOLT-HEX: .50 X 3.00 NC GR5 ZP	6
5	1027461	NUT-TOPLOCK: .50 NC GR5 ZP	42
6	54042	ROLLER-STEP 6"	2
7	62932	PLATE-SHIM .50 ZP	2
8	59711	TIGHTENER BOLT ZP	2
9	1026259	NUT-JAM: .63 NC GR2 ZP	4
10	1013816	BOLT-HEX: .63 X 5.00 NC GR5 ZP	2
11	1011813	WASHER-LOCK: .63 ZP	4
12	1011578	NUT-HEX: .63 NC GR2 ZP	2
13	53854	BOGIE WHEEL 4"	10
14	64192	STAND OFF	10
15	1013068	BOLT-HEX: .63 X 6.00 NC GR5 ZP	10
16	1016595	NUT-TOPLOCK: .63 NC GR5 ZP	14
17	59695	WLDMT-ROLLER MOUNT FRONT	1
18	1011606	BOLT-HEX: .50 X 1.25 NC GR5 ZP	14
19	1014443	WASHER-FLAT: .50 ZP	19
20	59454	IDLER ROLLER	4
21	1014000	BOLT-HEX: .63 X 3.50 NC GR5 ZP	4
22	301316	ASSY-FLAP CONVEYOR	1
23	1011618	BOLT-HEX: .50 X 5.00 NC GR5 ZP	5
24	1011607	BOLT-HEX: .50 X 1.50 NC GR5 ZP	5
25	62914	BRACKET-MOTOR MOUNT	1
26	57843	PLATE-MOTOR HYDRAULIC	1
27	59449	MOTOR-HYDRAULIC 20 IN <sup>3</sup> /REV	1
	57881	SEAL KIT FOR 59449	
28	1016999	NUT-TOPLOCK: .38 NC GR5 ZP	10
29	58679	BOLT-CRG: .38 X 1.50 NC GR5 ZP	3
30	1016362	BOLT-CRG: .38 X 1.25 NC GR5 ZP	3
31	53662	BEARING-FLANGE 1-7/16"	2
32	50152	KEY .38 X .38 X 2.00	2
33	53712	SPROCKET-SPLIT 45MM	2
34	52867	COUPLING	1
35	53392	SHAFT - DRIVE	1
36	59702	WLDMT-ROLLER MOUNT REAR	1
37	59725	WLDMT-KNOCKOUT BRACKET REAR	1
38	59720	SHAFT-KNOCKOUT WHEEL	1
39	301275	WLDMT-KNOCKOUT BRACKET FRONT	1

CONTINUED

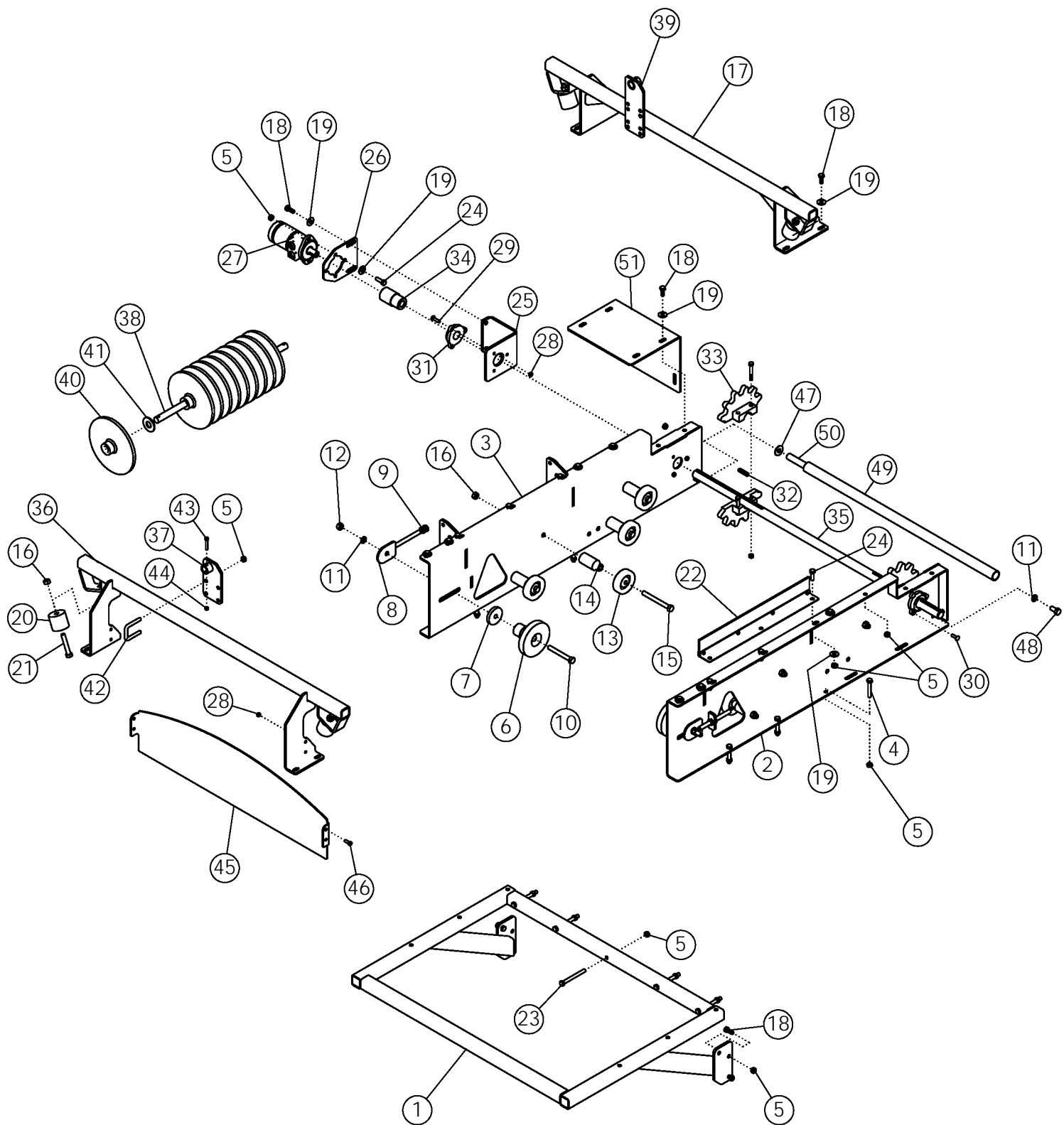

## WHEEL CONVEYOR (CONTINUED)

ITEM	PART NO.	DESCRIPTION	QTY
40	52876	KNOCKOUT WHEEL	10
41	1020685	WASHER-FLAT: 1.00	10
42	65658	U-BOLT: .50 X 3 X 2.06 X 3	4
43	1011285	BOLT-HEX: .31 X 2.00 NC	2
44	1030700	NUT-TOPLOCK: .31 NC GR5 ZP	2
45	64918	SHIELD-UPPER	1
46	1011600	BOLT-HEX: .38 X 1.00 NC GR5 ZP	4
47	1013024	WASHER-FLAT: .63 ZP	2
48	1032509	BOLT-HEX: .63 X 1.25 NC GR5 ZP	2
49	56773	PIPE-PLASTIC	1
50	56754	ROD-THREADED	1
51	301326	FLANGE-CONVEYOR EXTENSION SHIELD	2
52	301299	BELT-45MM WHEEL CONVEYOR 71LPR (NOT SHWN)	1

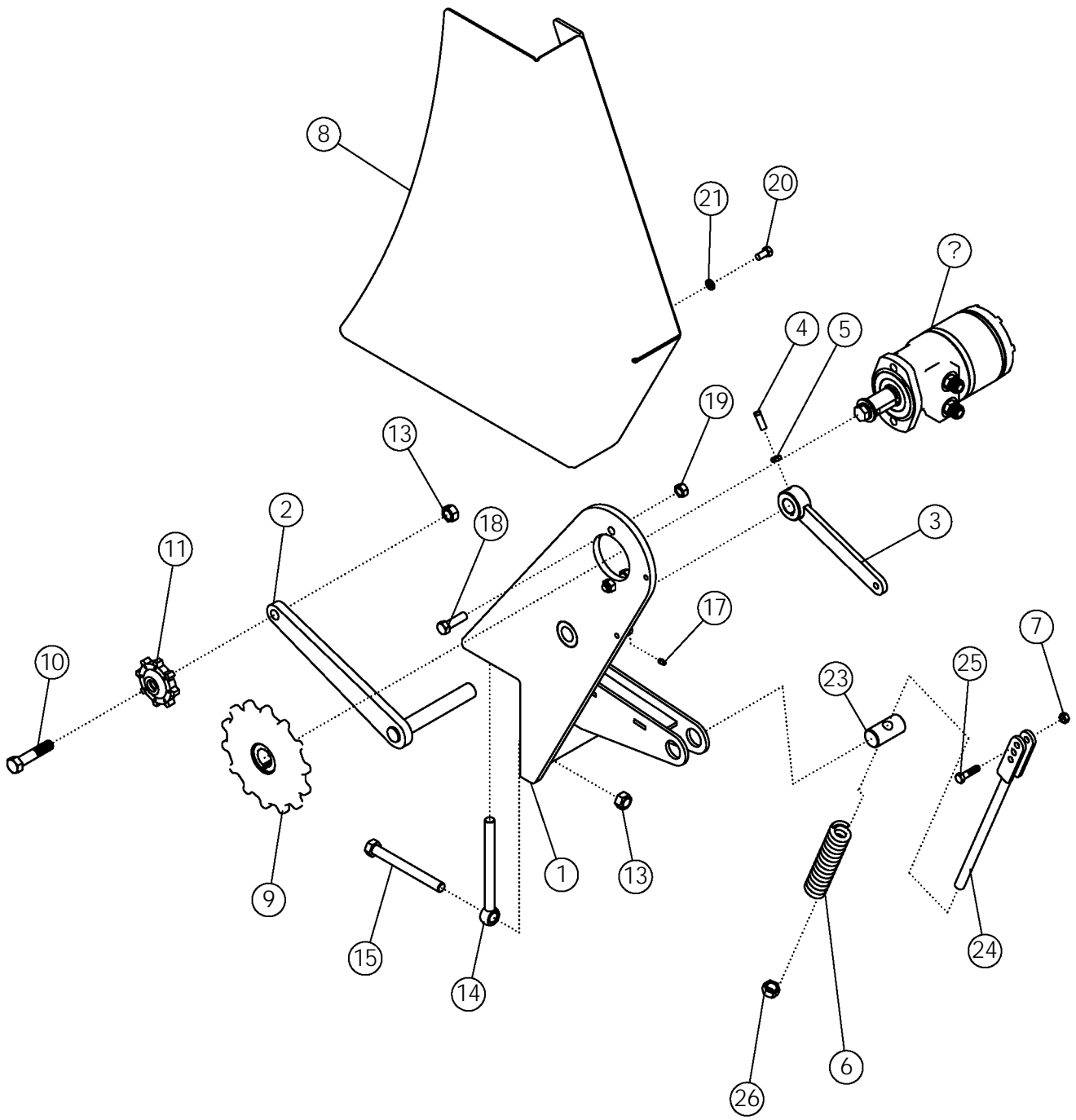



# WHEEL DRIVE

ITEM	PART NO.	DESCRIPTION	QTY
1	59618	WLDMT-MOTOR MOUNT	1
2	59624	WLDMT-IDLER ARM	1
3	50718	ARM-ZP	1
4	50813	SCREW-SET: SQ HD .38 X 1.00 ZP	1
5	1013519	NUT-JAM: .38 NC GR2 ZP	1
6	64915	SPRING	1
7	1016999	NUT-TOPLOCK: .38 NC GR5 ZP	1
8	59630	WLDMT-CHAIN GUARD	1
9	59978	WLDMT-DRIVE SPROCKET	1
10	1011624	BOLT-HEX: .63 X 3.00 NC GR5 ZP	1
11	59629	SPROCKET-IDLER	1
12	1013024	WASHER-FLAT: .63 ZP	1
13	1016595	NUT-TOPLOCK: .63 NC GR5 ZP	5
14	53195	EYEBOLT: .63 X 7.50 ZP	2
15	1013068	BOLT-HEX: .63 X 6.00 NC GR5 ZP	2
16	58987	MOTOR-HYDRAULIC 20.6IN <sup>3</sup> /REV	1
	57880	SEAL KIT FOR 58987	
17	1011748	ZERK - GREASE	1
18	1011608	BOLT-HEX: .50 X 1.75 NC GR5 ZP	2
19	1027461	NUT-TOPLOCK: .50 NC GR5 ZP	2
20	1011599	BOLT-HEX: .38 X 0.75 NC GR5 ZP	2
21	1011586	WASHER-LOCK: .38 ZP	2
22	59625	CHAIN-WHEEL DRIVE (NOT SHOWN)	1
23	64914	SHAFT-PIVOT	1
24	64913	SHAFT-ZP	1
25	1011602	BOLT-HEX: .38 X 1.50 NC GR5 ZP	1
26	1013302	NUT-NYLOCK: .63 NC GR2 ZP	1
27	1013004	WASHER-FLAT: SAE .63 ZP	2

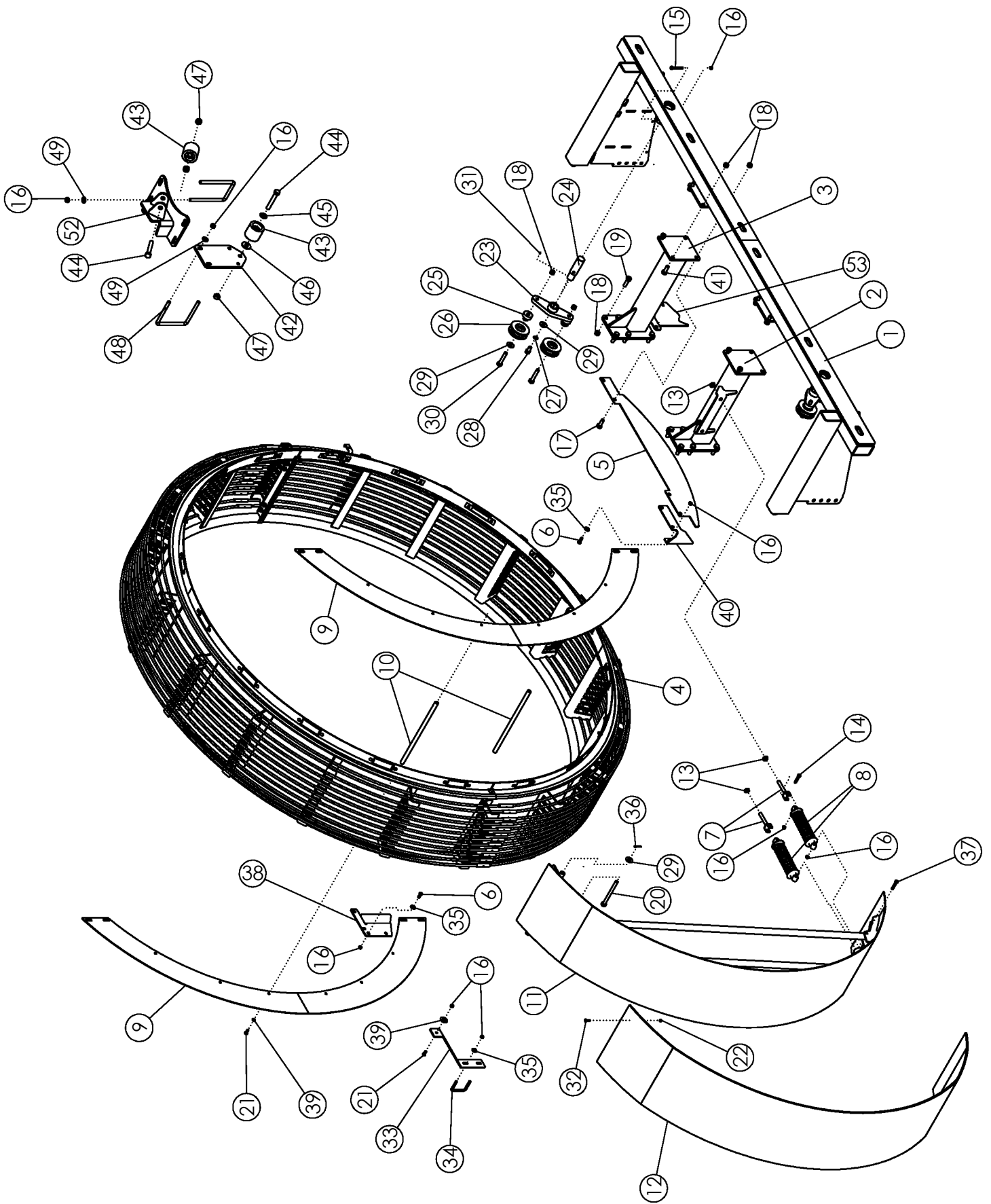

## FRAME EXTENSION

ITEM	PART NO.	DESCRIPTION	QTY
1	59413	WLDMT - FRAME EXT 6R22 WHEEL	1
2	59420	WLDMT - SUPPORT LH	1
3	58658	WLDMT - SUPPORT RH	1
4	59411	ASSY-WHEEL	1
5	69624	PLATE-DEFLECTOR WHEEL	1
6	1011606	BOLT-HEX: .50 X 1.25 NC GR5 ZP	9
7	59636	BOLT-CLEVIS ZP	2
8	59637	SHOCK-COIL SPRING	2
9	59461	WLDMT-SHIELD SHOE	2
10	59502	SLIDE SUPPORT	2
11	59470	WLDMT-SLIDE	1
12	64124	PLASTIC SLIDE	1
13	1011827	NUT-JAM: .75 NC GR2 ZP	4
14	1011610	BOLT-HEX: .50 X 2.50 NC GR5 ZP	2
15	1011612	BOLT-HEX: .50 X 3.50 GR5 ZP	2
16	1027461	NUT-TOPLOCK: .50 NC GR5 ZP	29
17	1012060	BOLT-HEX: .75 X 2.00 NC GR5 ZP	6
18	1017000	NUT-TOPLOCK: .75 NC GR5 ZP	32
19	1016598	BOLT-HEX: .75 X 2.50 NC GR5 ZP	14
20	69148	PIN-BOLT W/COTTER	2
21	1011096	BOLT-HEX: .50 X 1.00 NC GR5 ZP	4
22	1016999	NUT-TOPLOCK: .38 NC GR5 ZP	26
23	59437	WLDMT-ROLLER MOUNT	2
24	58726	SHAFT-MOUNT ROLLER	2
25	58910	STAND-OFF ROLLER	4
26	53681	ROLLER FLANGE	4
27	1012061	WASHER-LOCK: .75 ZP	2
28	58367	BOLT-HEX: .75 X 1.50 NC GR5 ZP	2
29	1030702	WASHER-FLAT: .75 ZP	8
30	1011625	BOLT-HEX: .75 X 4.00 NC GR5 ZP	4
31	1011748	ZERK-GREASE	2
32	58679	BOLT-CRG: .38 X 1.50 NC GR5 ZP	26
33	64979	PLATE-SHOE SHIELD BRACE	1
34	54653	U-BOLT: .50 X 3.25 X 4.00 X 3.25	1
35	1014443	WASHER-FLAT: .50 ZP	11
36	1030797	PIN-COTTER: .19 X 1.75 NP	2
37	1016858	BOLT-HEX: .50 X 2.75 NC GR5 ZP	2
38	303510	PLATE-WHEEL GRABROLL DEFLECTOR LH	1
39	1011581	WASHER-LOCK: .50 ZP	4
40	69623	PLATE-SHOE SHIELD MNT REAR	1
41	62412	BOLT-HEX: .75 X 1.75 NC GR5 ZP	8

CONTINUED

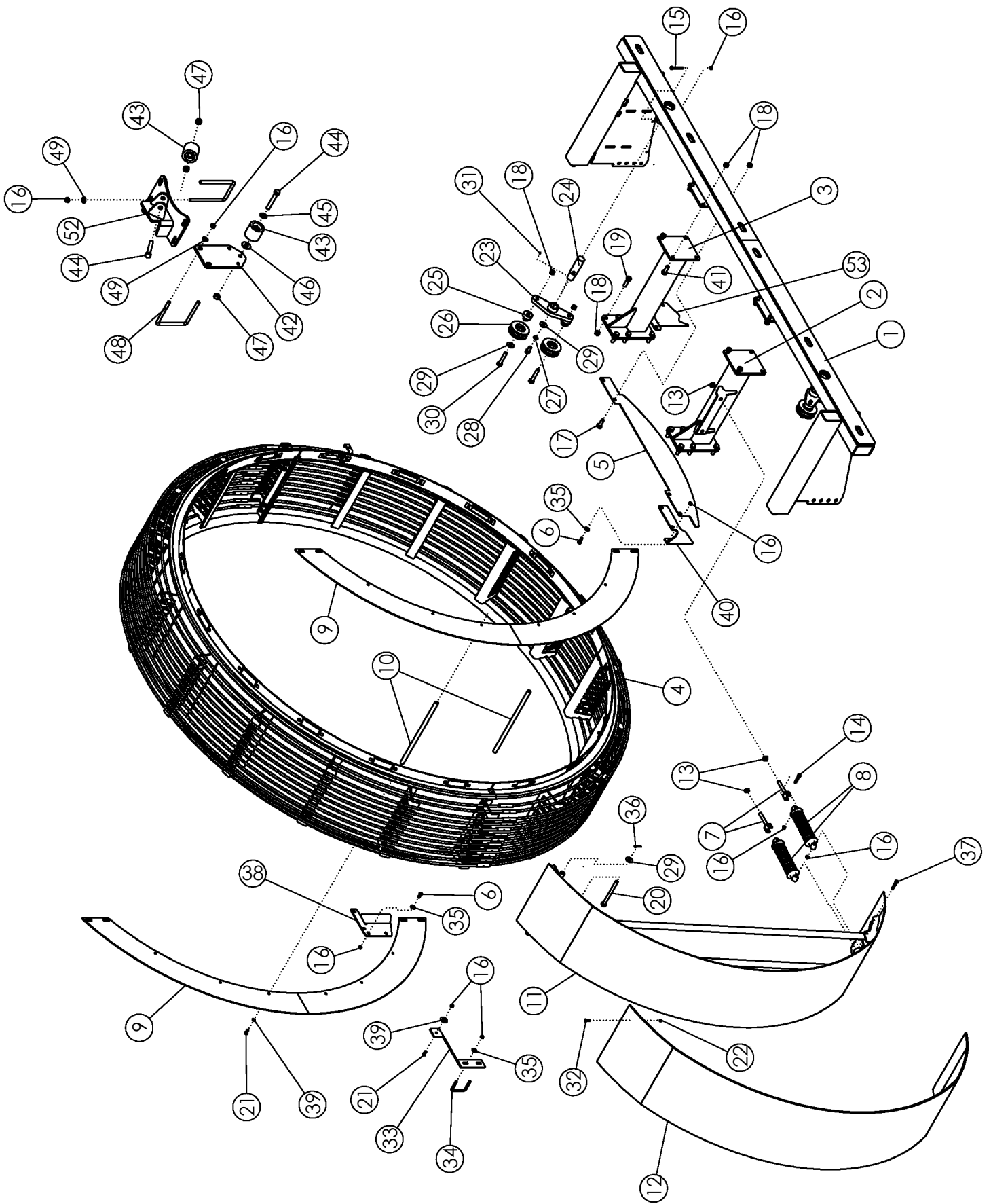

## FRAME EXTENSION (CONTINUED)

ITEM	PART NO.	DESCRIPTION	QTY
42	302527	PLATE-DROPDOWN	1
43	59454	IDLER ROLLER	3
44	1016726	BOLT-HEX: .63 x 4.00 NC GR5 ZP	3
45	1013004	WASHER-FLAT: SAE .63 ZP	9
46	1013024	WASHER-FLAT: .63 ZP	1
47	1016595	NUT-TOPLOCK: .63 NC GR5 ZP	3
48	34085	U-BOLT: .500 X 5.50 X 6.00 X 5.50	2
49	1011584	WASHER-FLAT: SAE .50 ZP	12
50	302534	WLDMT-SIDE ROLLER LH	1
51	34084	U-BOLT: .500 X 7.50 X 4.00 X 7.50	4
52	302535	WLDMT-SIDE ROLLER RH	1
53	303511	PLATE-WHEEL GRABROLL DEFLECTOR RH	1

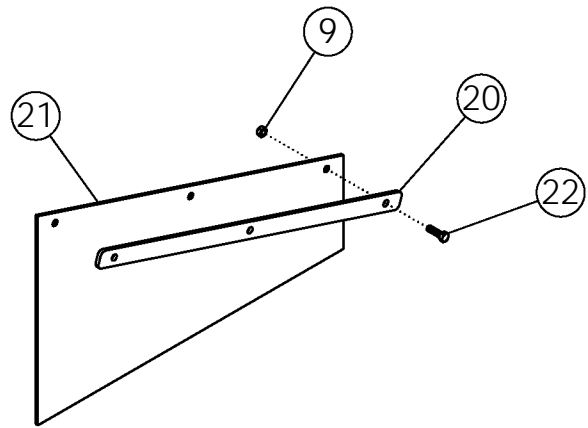
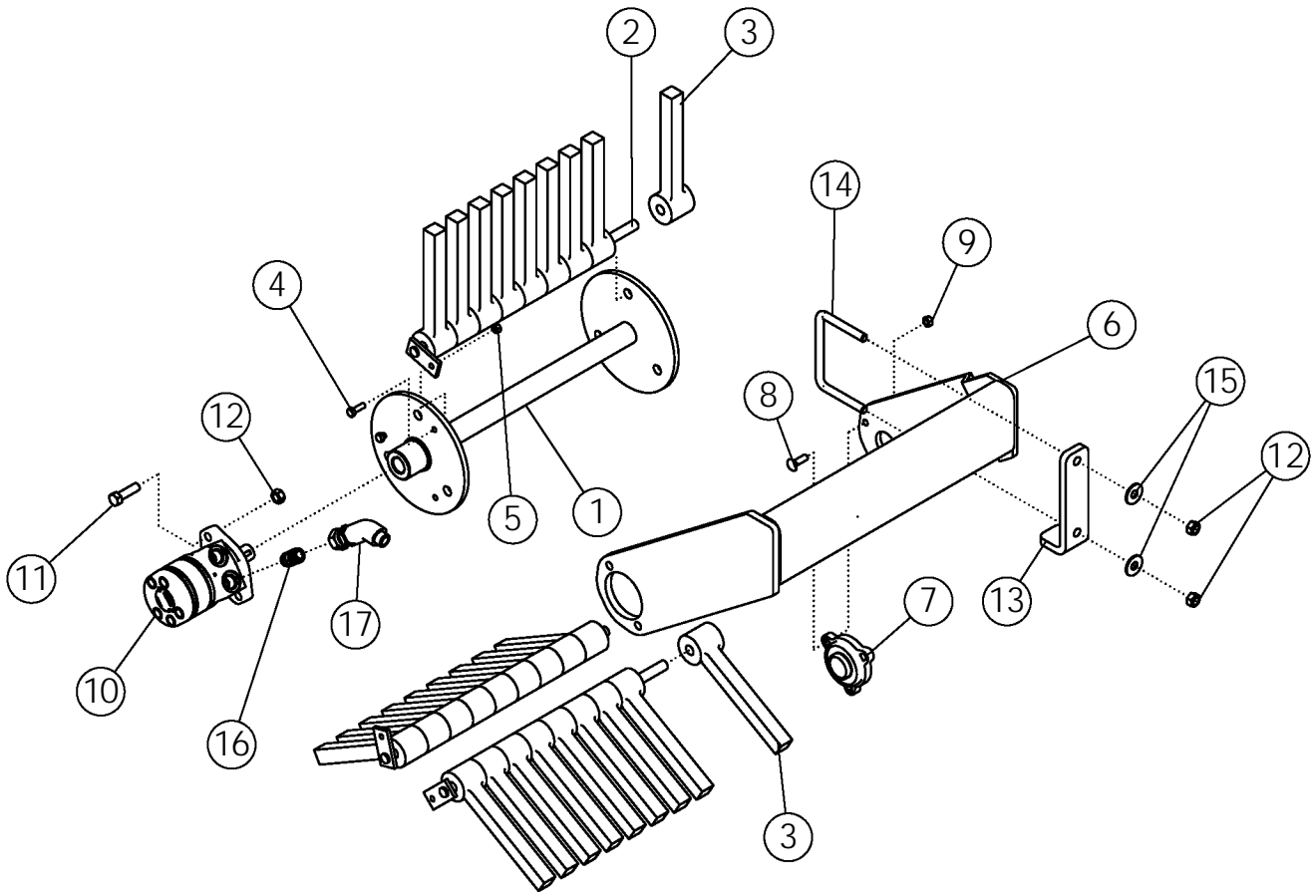

## WHEEL CLEANER (OPTIONAL)

ITEM	PART NO.	DESCRIPTION	QTY
1	59663	WLDMT-FLAIL SHAFT	1
2	59668	WLDMT-FLAIL ROD	3
3	59656	FLAIL-STRAIGHT 1"	27
4	1011598	BOLT-HEX: .31 X 1.00 NC GR5 ZP	3
5	1030700	NUT-HEX: .31 NC GR5 ZP	3
6	59658	WLDMT-WHEEL CLEANER MOUNT	1
7	53662	BEARING-FLANGE 1.44	1
8	1016362	BOLT-CRG: .38 X 1.25 NC GR5 ZP	3
9	1016999	NUT-TOPLOCK: .38 NC GR5 ZP	6
10	59674	MOTOR-HYDRAULIC 6.0 IN <sup>3</sup> /REV	1
	57881	SEAL KIT FOR 59674	
11	1011608	BOLT-HEX: .50 X 1.75 NC GR5 ZP	2
12	1027461	NUT-TOPLOCK: .50 NC GR5 ZP	6
13	59662	BRACKET-ADJUSTMENT	2
14	59673	U-BOLT: .50 X 3.75 X 5.00 X 3.75	2
15	1014443	WASHER-FLAT: .50 ZP	8
16	59043	FTG-ADAPTER: 10MB-12MJ	2
17	62014	FTG-ADAPTER: 12MJ-12FJX-45	2
18	59672	BOLT-TAP: .50 X 5.50 NC GR5 ZP	2
19	1011591	NUT-JAM: .50 NC ZP	2
20	62252	STRIP-BOLTING	1
21	62251	FLAP-DEFLECTOR	1
22	1011601	BOLT-HEX: .38 X 1.25 NC GR5 ZP	3

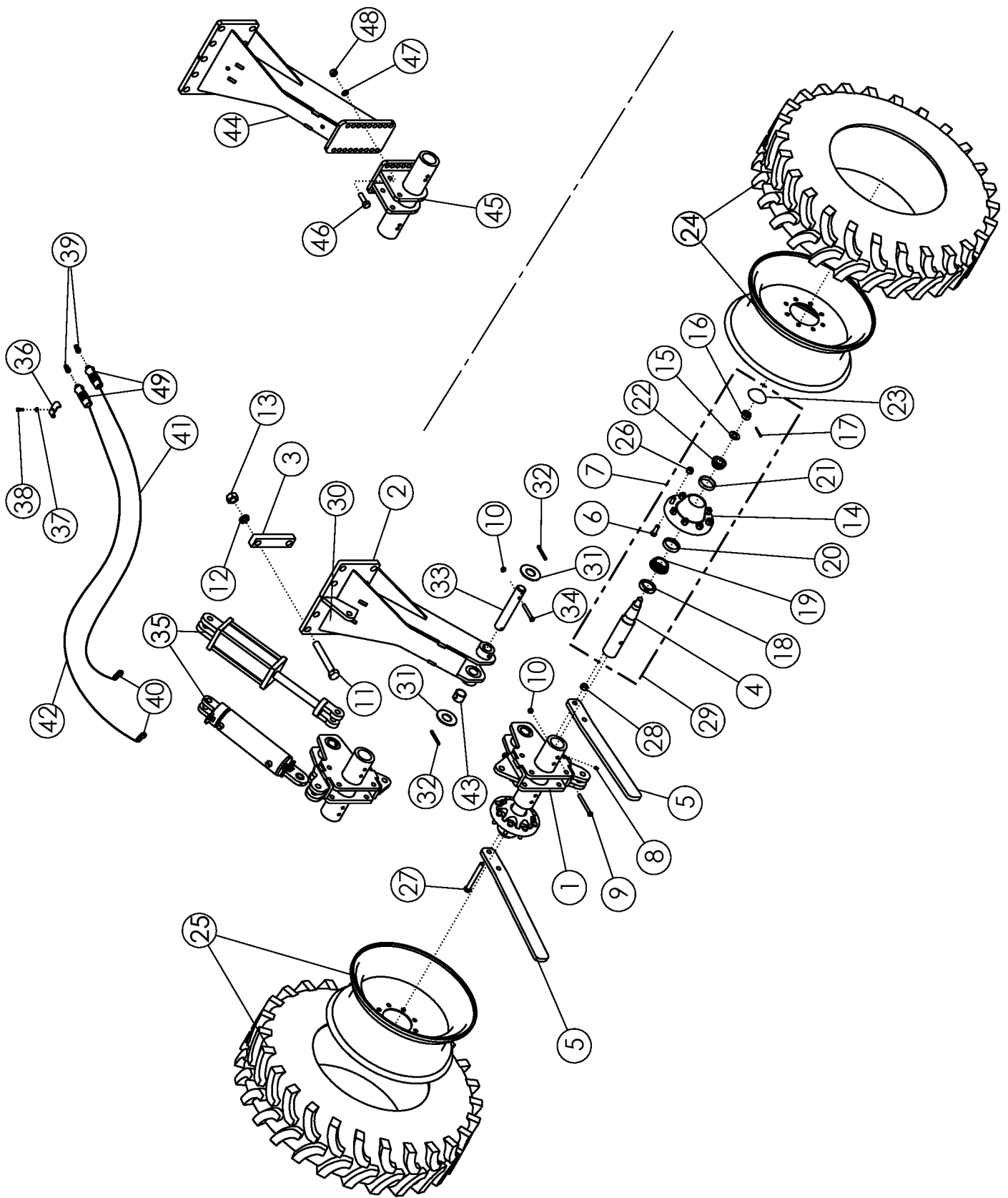



## STANDARD REAR STRUTS 11.2 X 24

ITEM	PART NO.	DESCRIPTION	QTY
1	300135	WLDMT-MOUNT ADJ 11.2-24 UNIVERSAL	2
2	69204	WLDMT-STRUT LH ADJ 11.2 X24	2
3	64143	BAR - BOLTING	4
4	52954*	SPINDLE-STANDARD	1
5	59045	SCRAPER	2
6	54393*	7600-6 STUD-HUB BOLT	8
7	301490	SELF TAPPING GREASE FITTING	1
8	1011748	ZERK-GREASE: .25 UNF STRAIGHT	1
9	1011618	BOLT-HEX: .50 X5.00 NC GR5 ZP	2
10	1027461	NUT-TOPLOCK: .50 NC GR5 ZP	10
11	64145	BOLT-HEX: 1.13 X8.00 NC GR8 ZP	8
12	64147	WASHER-LOCK: 1.13 ZP	8
13	64146	NUT-HEX: 1.13 NC GR2 ZP	8
14	53623*	HUB-WHEEL 8 BOLT	1
15	1030728*	WASHER-SPINDLE: 1.06ID X 2.13OD	1
16	1030726*	NUT-SPINDLE: 1.00 NF NP	1
17	1030797*	PIN-COTTER: .19 X 1.75 NP	1
18	53619*	SEAL	1
19	53621*	BEARING CONE-INNER	1
20	53622*	BEARING CUP-INNER	1
21	52243*	BEARING CUP-OUTER	1
22	53620*	BEARING CONE-OUTER	1
23	53624*	HUB CAP	1
24	56986	TIRE-MNTD: 11.2-24 10 PLY R1 RH	1
	56903	WHEEL W10 X 24 8 BOLT (1.88 POS)	
	56976	TIRE 11.2-24 10 PLY R1	
	68973	TUBE-REPAIR 11.2-24	
25	63992	TIRE-MNTD: 11.2-24 10 PLY R1 LH	1
	56903	WHEEL W10 X 24 8 BOLT (1.88 POS)	
	56976	TIRE 11.2-24 10 PLY R1	
	68973	TUBE-REPAIR 11.2-24	AR
26	53625*	NUT-WHEEL: .63-18NF	8
27	1016718	BOLT-HEX: .75 X6.50 NC GR5 ZP	2
28	1017000	NUT-TOPLOCK: .75 NC GR5 ZP	2
29	53167	ASSY-HUB & SPINDLE 8-BOLT	2
30	303969	DECAL-TIRE 11.2-24	1
31	73368	WASHER-FLAT: 1.75 ZP	2
32	73369	ROLL PIN: .38 X3.50 ZP	2
33	301238	PIN-STRUT REAR ADJ	1
34	1032524	BOLT-HEX: .50 X 4.00 NC GR5 ZP	1

CONTINUED

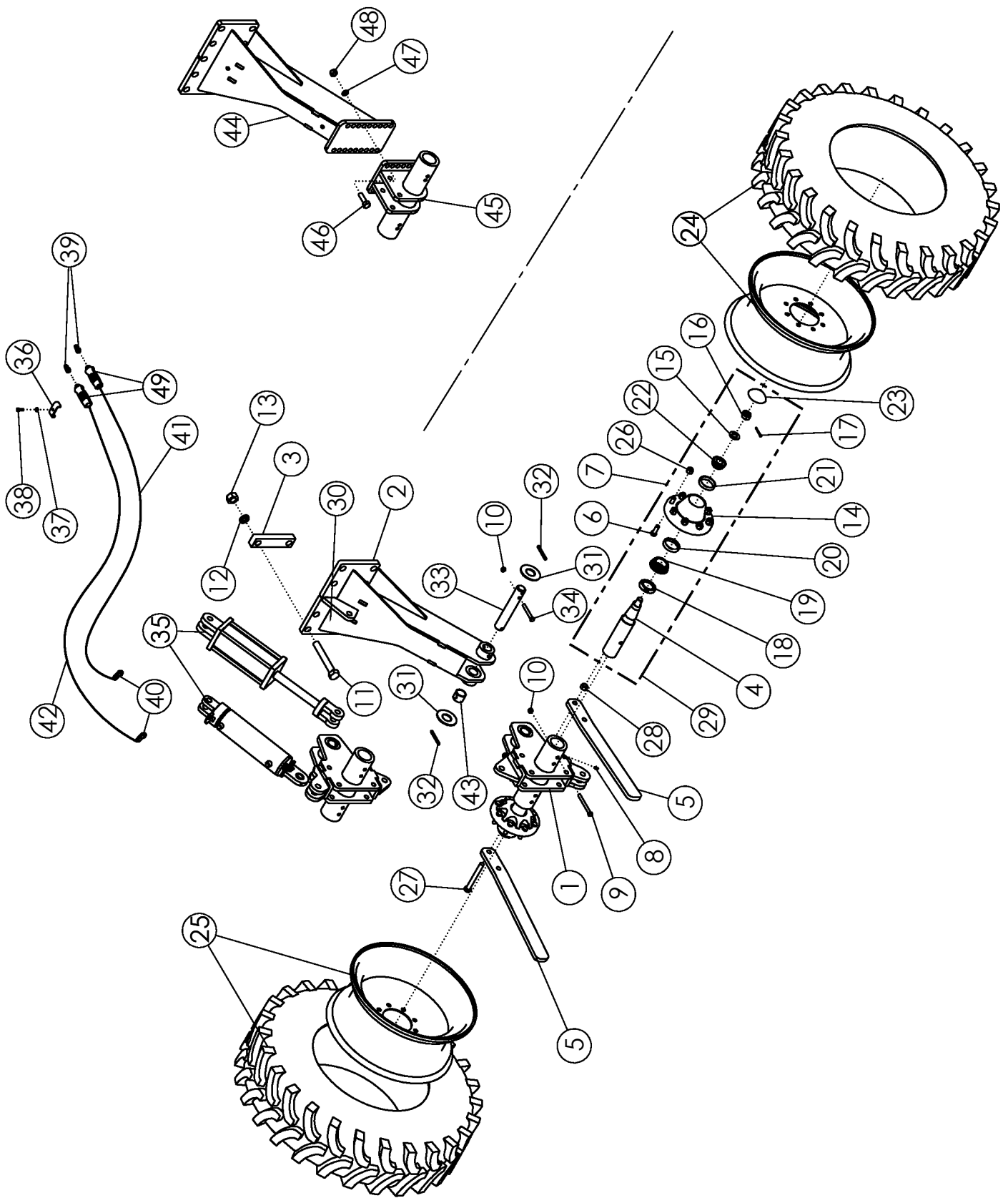

<b>STANDARD REAR STRUTS (CONTINUED)</b>			
<b>ITEM</b>	<b>PART NO.</b>	<b>DESCRIPTION</b>	<b>QTY</b>
35	72950	CYLINDER-HYDRAULIC 4 X 10	1
	301315	SEAL KT-CYL 4 X 8, 4 X 10 3000PSI UNIVERSAL	
	73421	CYLINDER-HYD 4 X 10-3000-0° ADC	
	73629	SEAL KIT FOR 73421	
36	50714	CLAMP .50 ZP	6
37	1011586	WASHER-LOCK: .38 ZP	6
38	1011600	BOLT-HEX: .38 X 1.00 NC GR5 ZP	6
39	36290	PIONEER TIP 8010-15P (#8 ORB)	2
40	58560	FTG-ELBOW: 8MB-8MJ-90	2
41	66596	HOSE: .50 X 320 8FJX-8MB	1
42	67670	HOSE: .50 X 312 8MB-8FJX	1
43	301237	BUSHING-SPRING 2.00 X 1.75 X 1.50	2
44	69206**	WLDMT-STRUT RH STD 11.2-24	1
45	302551**	WLDMT-UNIVERSAL SPINDLE MOUNT	1
46	1016598**	BOLT-HEX: .75 X 2.50 NC GR5 ZP	6
47	1012061**	WASHER-LOCK: .75 ZP	6
48	1011620**	NUT-HEX: .75 NC GR2 ZP	6
49	302227	HYD LABEL: .50 BLUE/YELLOW SET (LH SIDE)	1
	302230	HYD LABEL: .50 RED/GREEN SET (RH SIDE)	1

\* ITEMS INCLUDED IN ITEM 29

\*\* ITEMS ARE INCLUDED ONLY IN STANDARD STRUT OPTION

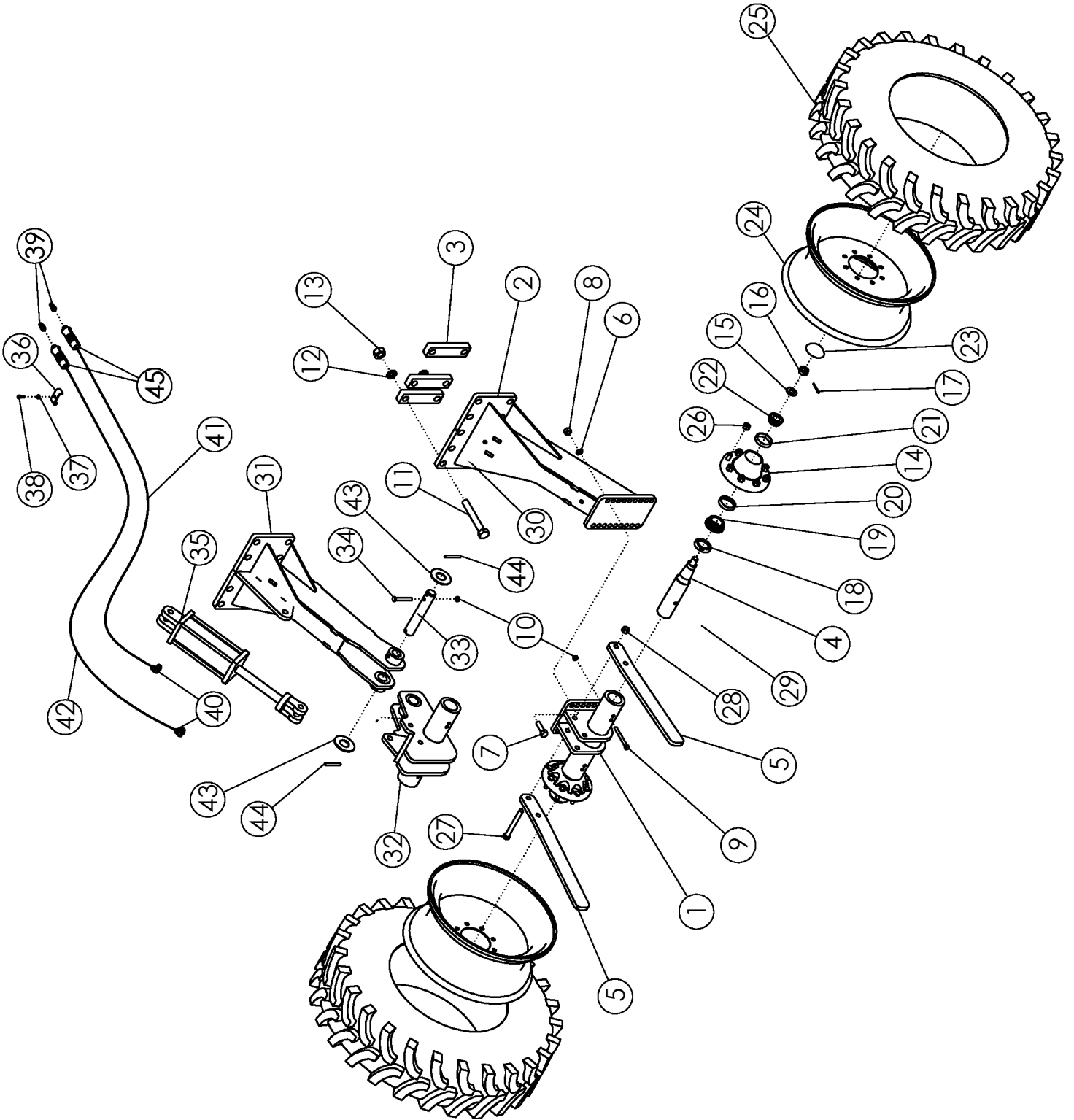



## STANDARD REAR STRUTS 14.9 X 30

ITEM	PART NO.	DESCRIPTION	QTY
1	57233	WLDMT - MOUNT STANDARD	1
2	69809	WLDMT-STRUT STD RH	1
3	64143	BAR - BOLTING	4
4	52954*	SPINDLE-STANDARD	1
5	59045	SCRAPER	2
6	1012061	WASHER-LOCK: .75 ZP	6
7	1016598	BOLT-HEX: .75 X 2.50 NC GR5 ZP	6
8	1011620	NUT-HEX: .75 NC	6
9	1011618	BOLT-HEX: .50 X 5.00 NC GR5 ZP	2
10	1027461	NUT-TOPLOCK: .50 NC GR5 ZP	2
11	64145	BOLT-HEX: 1.13 X 8.00 NC GR8 ZP	8
12	64147	WASHER-LOCK: 1.13 ZP	8
13	64146	NUT-HEX: 1.13 NC GR2 ZP	8
14	53623*	HUB-WHEEL 8 BOLT	1
15	1030728*	WASHER-SPINDLE: 1.06ID X 2.13OD	1
16	1030726*	NUT-SPINDLE: 1.00 NF NP	1
17	1030797*	PIN-COTTER: .19 X 1.75 NP	1
18	53619*	SEAL	1
19	53621*	BEARING CONE-INNER	1
20	53622*	BEARING CUP-INNER	1
21	52243*	BEARING CUP-OUTER	1
22	53620*	BEARING CONE-OUTER	1
23	53624*	HUB CAP	1
24	69921	WHEEL W13 X 30 8 BOLT (1.88 POS)	2
25	69922	TIRE 14.9-30 10 PLYR1	2
26	53625*	NUT-WHEEL: .63-18NF	8
27	1016718	BOLT-HEX: .75 X 6.50 NC GR5 ZP	2
28	1017000	NUT-TOPLOCK: .75 NC GR5 ZP	2
29	53167	ASSY-HUB & SPINDLE 8-BOLT	2
30	303969	DECAL-TIRE 11.2-24	1
31	69815	WLDMT-STRUT LH ADJ 14.9 X 30	1
32	69930	WLDMT-MOUNT ADJ STRUT 14.9 X 30	1
33	73367	PIN-REAR STRUT ADJ	1
34	1032524	BOLT-KHEX: .50 X 4.00 NC GR8 NP	1
35	72950	CYLINDER-HYDRAULIC 4 X 10	1
	301315	SEAL KT-CYL 4 X 8, 4 X 10 3000PSI UNIVERSAL	
36	50714	CLAMP .50 ZP	6
37	1011586	WASHER-LOCK: .38 ZP	6
38	1011600	BOLT-HEX: .38 X 1.00 NC GR5 ZP	6
39	36290	PIONEER TIP 8010-15P (#8 ORB)	2
40	58560	FTG-ELBOW: 8MB-8MJ-90	2
41	67670	HOSE: .50 X 312 8MB-8FJX	1
42	66596	HOSE: .50 X 320 8FJX-8MB	1
43	73368	WASHER-FLAT: 1.75 ZP	2
44	73369	PIN-ROLL: .38 X 3.50 ZP	2
45	302227	HYD LABEL: .50 BLUE/YELLOW SET (LH SSIDE)	1
	302230	HYD LABEL: .50 RED/GREEN SET (RH SIDE)	1

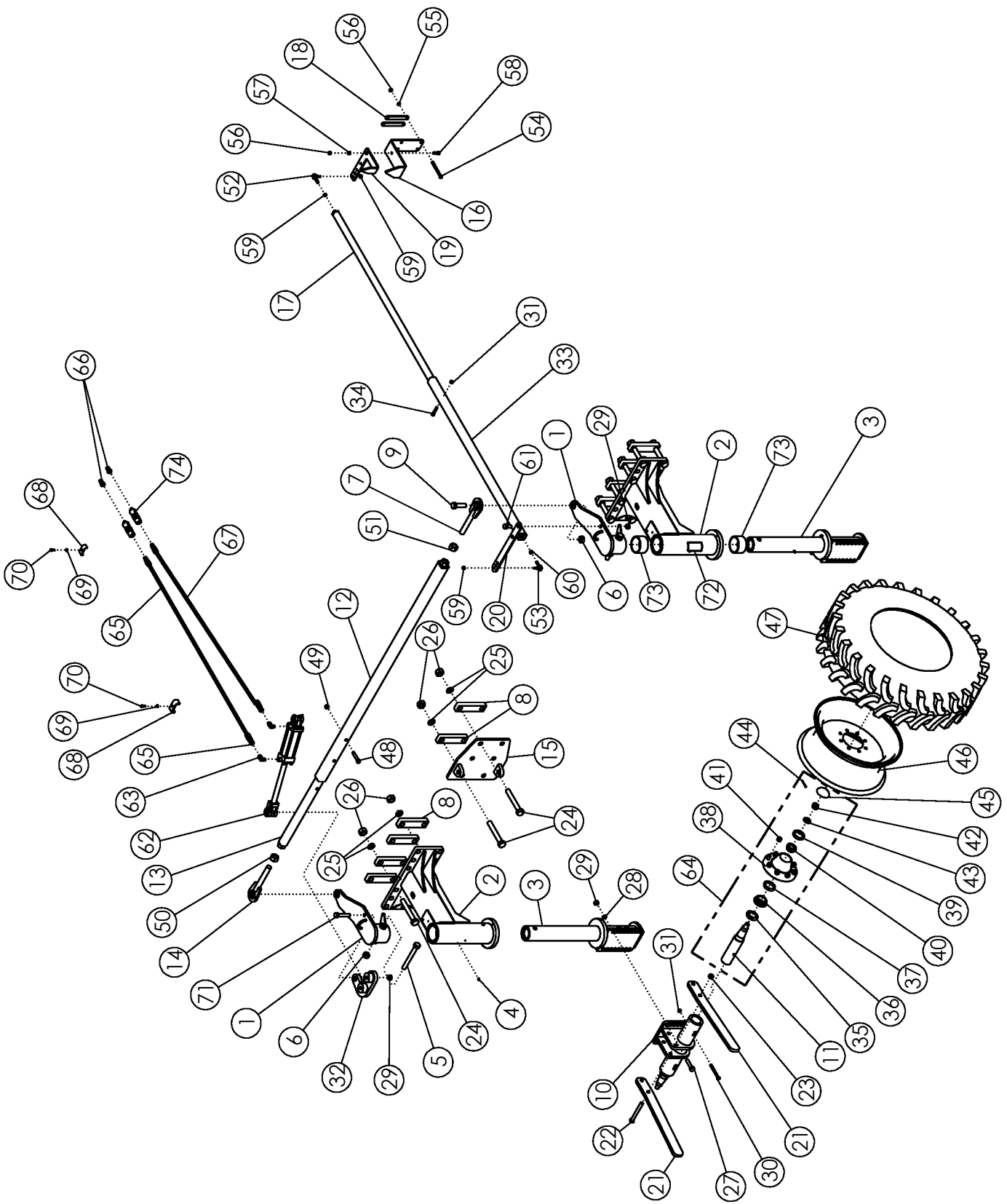

## STEERABLE REAR STRUTS

ITEM	PART NO.	DESCRIPTION	QTY
1	58240	WLDMT - STEERING ARM	2
2	58285	WLDMT-STEERING HOUSING R.H.	1
3	58238	WLDMT - KING PIN	2
4	1011748	ZERK - GREASE	10
5	1033376	BOLT-HEX: 1.0 x 8.50 NC GR8 ZP	2
6	1016969	NUT-TOPLOCK: 1.00 NC GR5 ZP	4
7	58186	WLDMT-TIE ROD RH	1
8	64143	BAR - BOLTING	6
9	1032276	BOLT-HEX: 1.0 x 3.50 NC GR8 ZP	2
10	57233	WLDMT - MOUNT STANDARD	2
11	52954	SPINDLE-STANDARD	4
12	58374	WLDMT-TIE ROD EXTENSION	1
13	58341	WLDMT-TIE ROD	1
14	58203	WLDMT-TIE ROD LH	1
15	58239	WLDMT-STEERING HOUSING LH	1
16	53278	MOUNT-INDICATOR	1
17	59492	*ASSY DESC.*	1
18	56809	BAR-BOLTING	2
19	58348	INDICATOR	1
20	58346	ARM-STEERING INDICATOR	1
21	59045	SCRAPER	4
22	1012059	BOLT-HEX: .75 X 6.50 NC GR5 ZP	4
23	1017000	NUT-TOPLOCK .75 NC GR5 ZP	4
24	64145	BOLT-HEX: 1.125 X 8.00 NC GR8 ZP	12
25	64147	WASHER-LOCK: 1.125 ZP	12
26	64146	NUT-HEX: 1.125 NC GR2 ZP	12
27	1012059	BOLT- .75 X 3.00 NC GR5 ZP	12
28	1012061	WASHER-LOCK: .75 ZP	12
29	1011620	NUT: .750 NC	15
30	1011618	BOLT-HEX: .50 X 5.00 NC GR5 ZP	4
31	1027461	NUT-TOPLOCK: .50 NC GR5 ZP	5
32	58123	PLATE	1
33	59493	WLDMT-TIE ROD EXTENSION	1
34	1011610	BOLT-HEX: .50 x 2.50 NC GR5 ZP	1
35	53619	SEAL	4
36	53621	CONE-BEARING	4
37	53622	CUP-BEARING INNER	4
38	53623	HUB-WHEEL 8 BOLT	4
39	52243	BEARING CUP	4
40	53620*	BEARING-CONE	4

CONTINUED

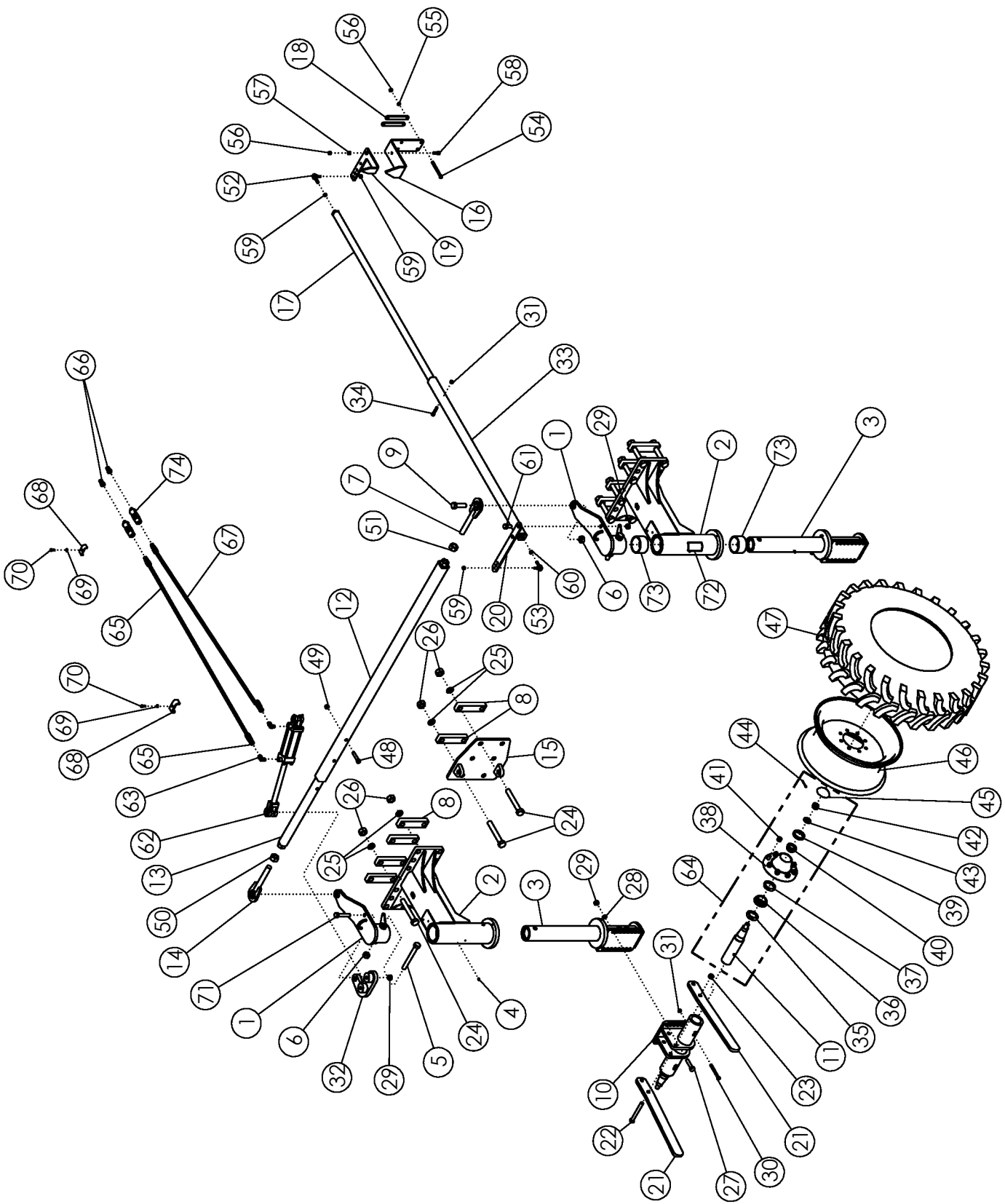



## STEERABLE REAR STRUTS (CONTINUED)

ITEM	PART NO.	DESCRIPTION	QTY
41	53625*	NUT-WHEEL: .63-18NF	32
42	1030726*	NUT-SPINDLE: 1.00 NF NP	4
43	1030728*	WASHER-SPINDLE: 1.06ID X 2.13OD	4
44	1030797*	PIN-COTTER: .19 X 1.75 NP	4
45	53624*	HUB CAP	4
46	56903	WHEEL W10 X 24 8 BOLT (1.875 POS)	4
47	56976	TIRE 11.2-24 10 PLY R1	4
	68973	TUBE-REPAIR 11.2-24 (NOT SHOWN)	AR
48	1030704	BOLT-HEX: .63 X 3.25 NC GR5 ZP	1
49	1011578	NUT-HEX: .63 NC GR2 ZP	1
50	1030729	NUT-HEX: 1.25 NC GR2 ZP LH	1
51	1011621	NUT-HEX: 1.25 NC GR2 ZP	1
52	58350	BALL JOINT ROD END 1/2-20NF RH	1
53	58351	BALL JOINT ROD END 1/2-20NF LH	1
54	1016660	BOLT-HEX: .50 X 5.50 NC GR5 ZP	4
55	1011581	WASHER-LOCK: .50 ZP	4
56	1011577	NUT-HEX: .50 NC GR2 ZP	5
57	56884	BUSHING-INDICATOR REAR STRUT	1
58	1011607	BOLT-HEX: .50 X 1.50 NC GR5 ZP	1
59	58355	NUT-HEX: .50 NF GR5 ZP RH	3
60	58366	NUT-HEX: .50 NF GR5 ZP LH	1
61	58367	BOLT-HEX: .75 X 1.50 NC GR5 ZP	2
62	58890	CYLINDER HYDRAULIC 3 X 8	1
	301314	SEAL KIT FOR 58890 UNIVERSAL	
63	58560	FTG-ELBOW: 8MB-8MJ-90	2
64	53167	ASSY-HUB & SPINDLE 8 BOLT	2
65	300029	HOSE: .50 X 276 8MB-8FJX	1
66	36290	PIONEER TIP 8010-15P (#8 ORB)	2
67	66604	HOSE: .50 X 290 8FJX-8MB	1
68	50714	CLAMP 1/2" ZP	4
69	1011586	WASHER-LOCK: .38 ZP	4
70	1011600	BOLT-HEX: .38 X 1.00 NC GR5 ZP	4
71	1011625	BOLT-HEX: .75 X 4.00 NC GR5 ZP	2
72	303969	DECAL-TIRE 11.2-24	1
73	59205	BUSHING-BORED 4.5 X 4.025	4
74	301908	HYD LABEL: .50 RED/GRAY SET	1

\* Items are included in Item 64

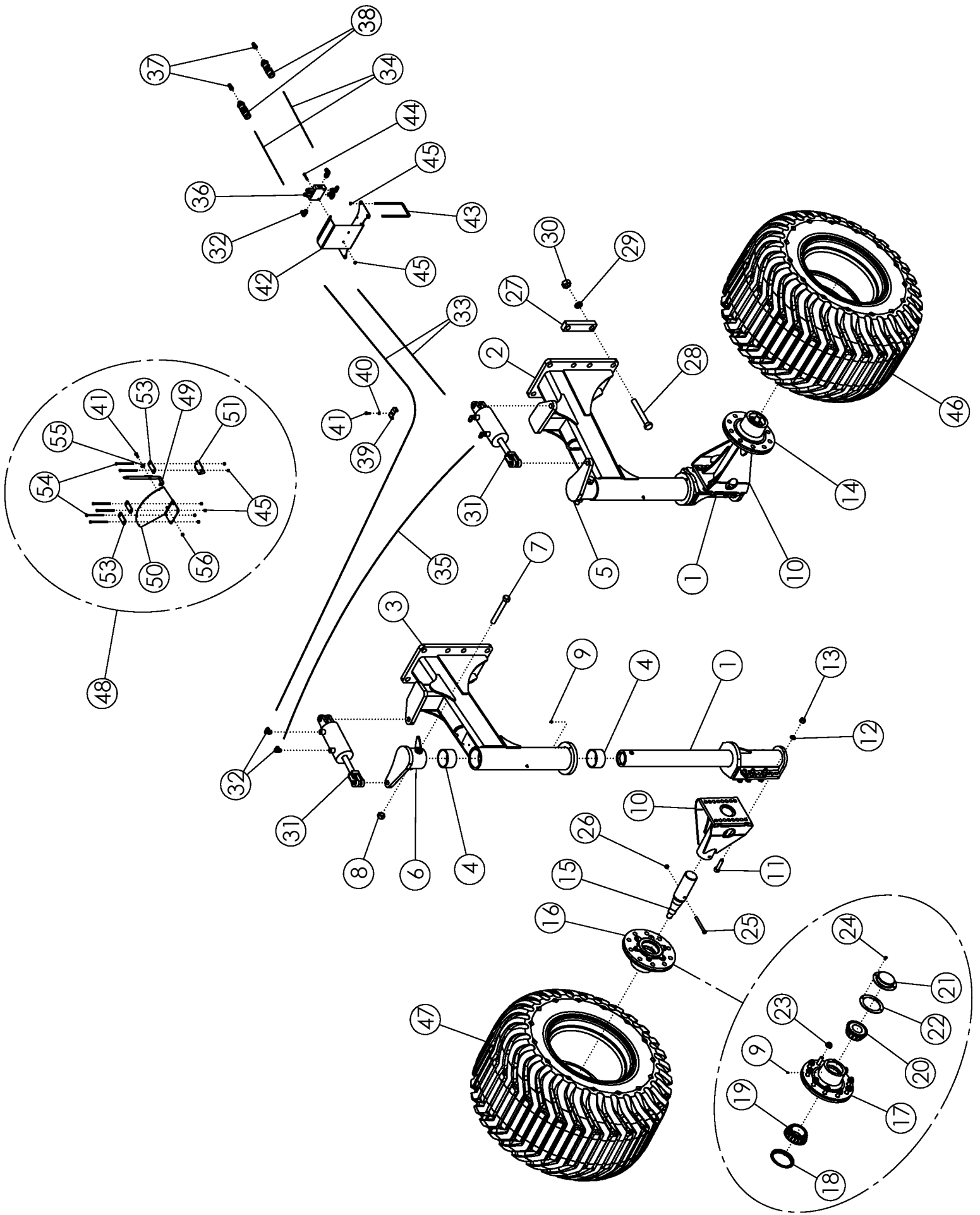

## SINGLE STEERABLE REAR STRUT 710/40R22.5

ITEM	PART NO.	DESCRIPTION	QTY
1	302045	WLDMT-WHEEL SWMVL	2
2	302036	WLDMT-STEERING HOUSING RH	1
3	302035	WLDMT-STEERING HOUSING LH	1
4	59205	BUSHING-BORED 4.500 X4.025	4
5	302266	WLDMT-STEERING ARM RH	1
6	302056	WLDMT-STEERING ARM LH	1
7	1030725	BOLT-HEX: 1.00 X 8.00 NC GR8 ZP	2
8	1016969	NUT-TOPLOCK: 1.00 NC GR8 ZP	2
9	1011748*	ZERK-GREASE: .25 UNF STRAIGHT	8
10	302463	WLDMT-BOLT WHEEL POD EXT	2
11	1012059	BOLT-HEX: .75 X 3.00 NC GR5 ZP	16
12	1012061	WASHER-LOCK: .75 ZP	16
13	1011620	NUT-HEX: .75 NC GR2 ZP	16
14	35519	ASSY-HUB & SPINDLE: 10-BOLT 12000#	2
15	35519-1*	SPINDLE: 3.13 X 14.5	2
16	35519-2*	ASSY-HUB 10 BOLT-11.25 BC 12000#	2
17	320139*	HUB-WHEEL 10 BOLT-11.25 (BLACK)	2
18	320143*	SEAL-OIL	2
19	320144*	BEARING CONE-OUTER	2
20	320145*	BEARING CONE-INNER	2
21	320146*	CAP-HUB	2
22	320148*	GASKET-CAP HUB	2
23	320147*	NUT-WHEEL	20
24	1011596*	BOLT-HEX: .31 X .50 NC GR5 ZP	8
25	1011618	BOLT-HEX: .50 X 5.00 NC GR5 ZP	2
26	1027461	NUT-TOPLOCK: .50 NC GR5 ZP	2
27	64143	BAR-BOLTING	8
28	302426	BOLT-HEX: 1.12 X 8.50 NC GR8 YZP	16
29	64147	WASHER-LOCK: 1.13 GR2 ZP	16
30	64146	NUT-HEX: 1.125 NC GR5 ZP	16
31	302265	CYL-REPHASE IN SERIES, 4.0 X 6.0 SLAVE	2
32	58560	FTG-ELBOW: 8MB-8MJ 90	8
33	58377	HOSE: .50 X 172 8FJX-8FJX	2
34	37705	HOSE: .50 X 128 8FJX-8MB	2
35	73496	HOSE: .50 X 144 8FJX-8FJX	1
36	73426	VALVE-DUAL COUNTER BALANCE	1
37	36290	PIONEER TIP 8010-15P (#8 ORB)	2
38	301908	HYD LABEL: .50 RED/GRAY SET	1
39	50714	CLAMP 1/2" ZP	4
40	1011586	WASHER-LOCK: .38 ZP	4
41	1011600**	BOLT-HEX: 38 X 1.00 NC GR5 ZP	5

CONTINUED

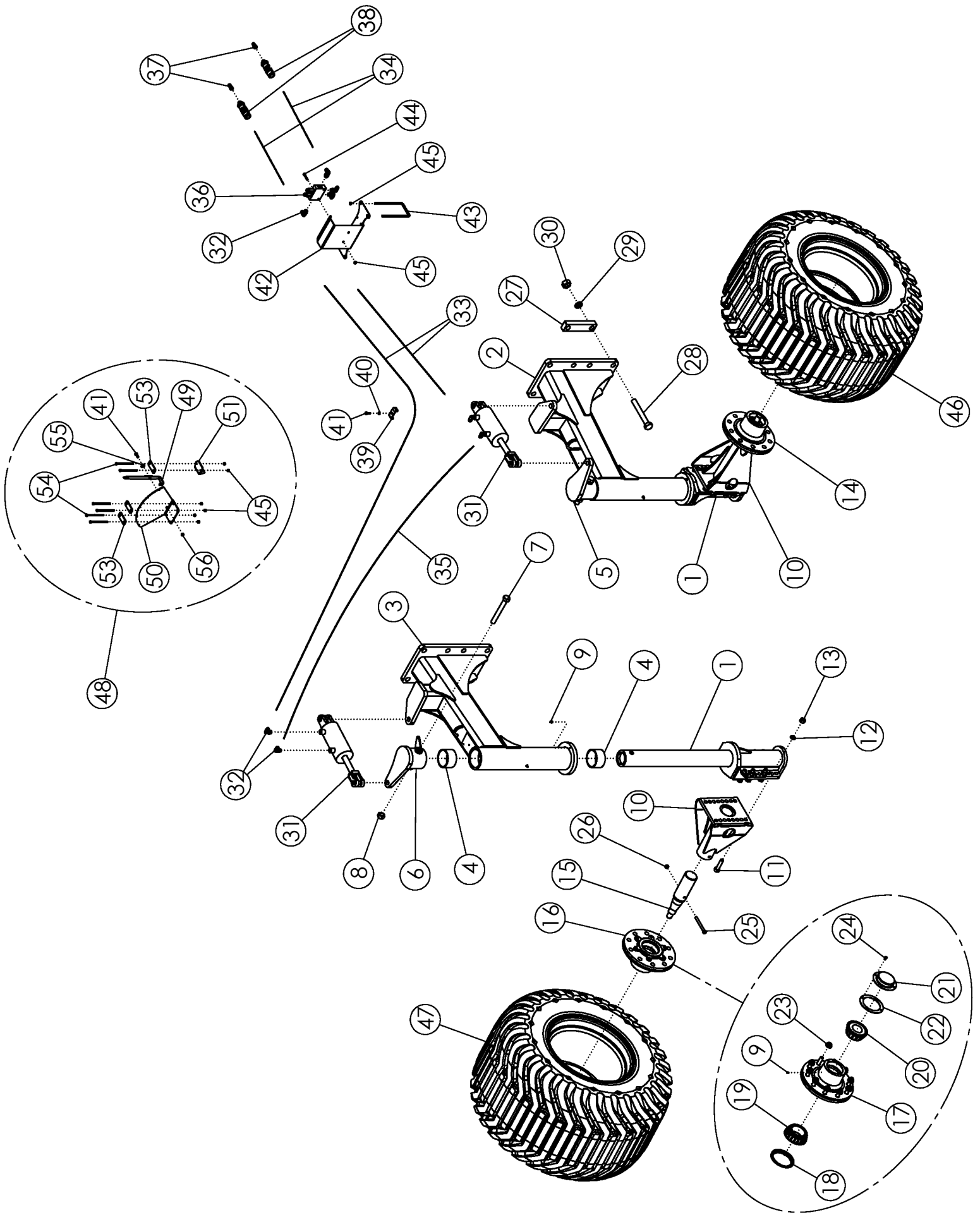



## SINGLE STEERABLE REAR STRUT 710/40R22.5 (CONTINUED)

ITEM	PART NO.	DESCRIPTION	QTY
42	302931	PLATE-COUNTER BALANCE VALVE MOUNT	1
43	304031	U-BOLT: .375 X 8.13 X 4.00 X 8.13 ZP	2
44	1013424	BOLT-HEX: .31 X 1.75 NC GR5 ZP	2
45	1030700**	NUT-TOPLOCK: .31 NC GR5 ZP	12
46	302569	TIRE-MNTD: 710/40R22.5 RH	1
	302571	WHEEL 22.5 X 24.5 OUTSET	
	302572	TIRE 710/40R22.5 SUPERFLOT	
47	302570	TIRE-MNTD: 710/40R22.5 LH	1
	302571	WHEEL 22.5 X 24.5 OUTSET	
	302572	TIRE 710/40R22.5 SUPERFLOT	
48	302897	ASSY-SINGLE TIRE STEERING INDICATOR	1
49	73434**	PLATE-INDICATOR DIAL	1
50	73435**	PLATE-INDICATOR GAUGE	1
51	73436**	PLATE-INDICATOR CABLE MOUNT	1
52	73441**	PUSH-PULL CABLE 10-32 X 9' 4" STRK (NOT SHOWN)	1
53	301931**	PLATE-BOLTING BAR STEERING INDICATOR	3
54	302363**	BOLT-HEX: .31 X 5.00 NC GR5 ZP	6
55	1011828**	WASHER-FLAT: .38 ZP	2
56	1016999**	NUT-TOPLOCK: .38 NC GR5 ZP	1
57	37761**	P-CLIP .38 X 1.00 (NOT SHOWN)	1

\*ITEMS INCLUDED IN ITEM 14

\*\*ITEMS INCLUDED IN ITEM 48

ASSEMBLED VIEW

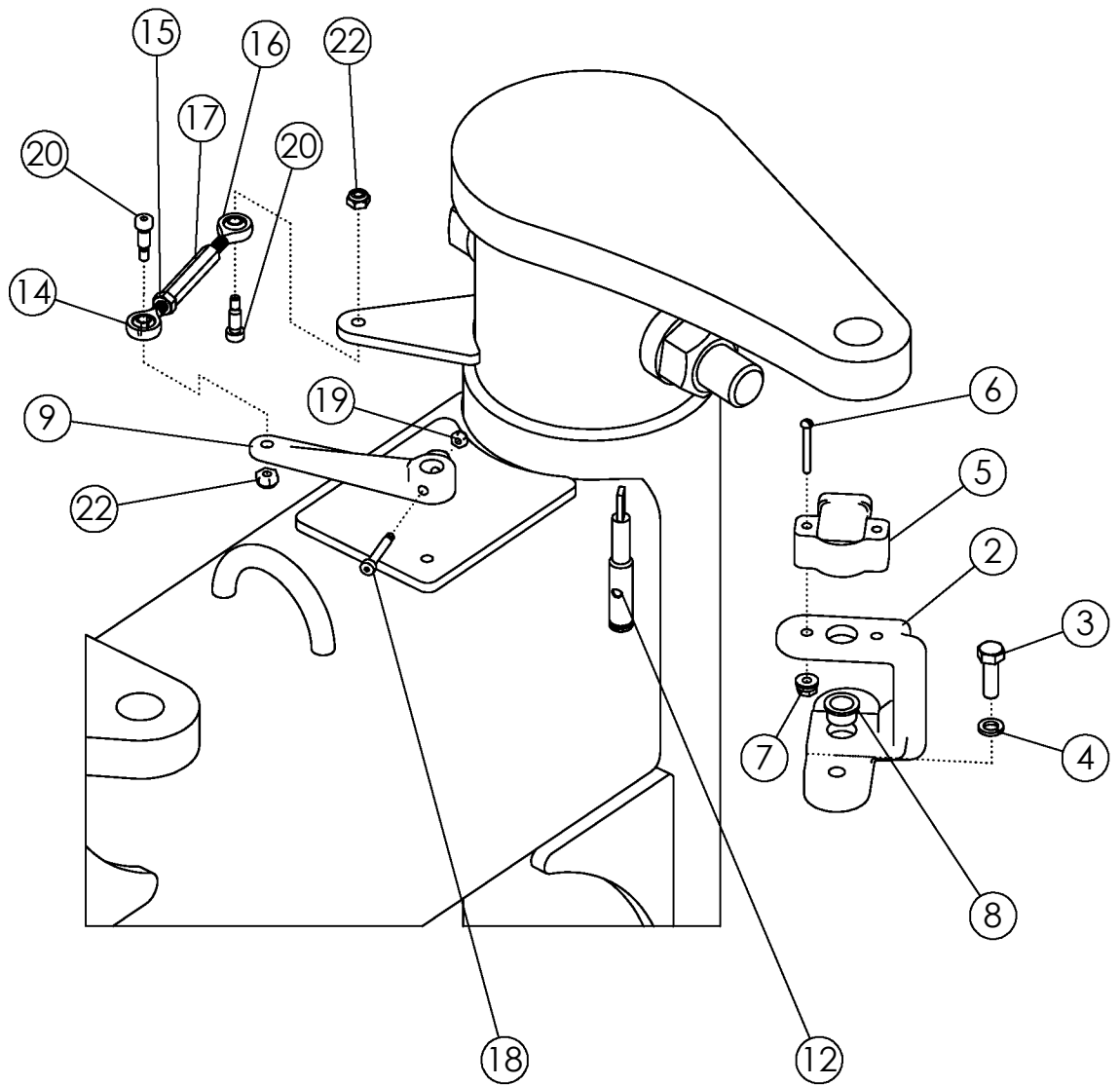
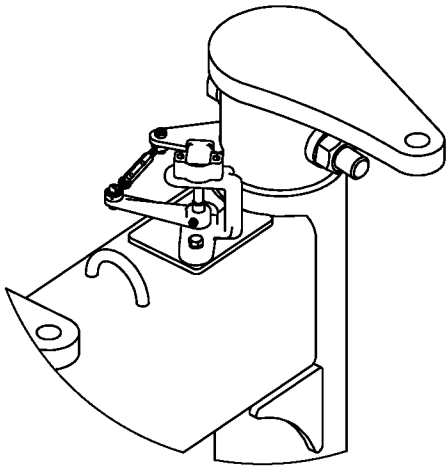

## KIT JD TOUCHSET FOR SINGLE STEERABLES

ITEM	PART NO.	DESCRIPTION	QTY
1	302778	HARNESS-JOHN DEERE TOUCH SET	1
2	306821	SENSOR BRACKET-DLS	1
3	1011598	BOLT-HEX: .31 X 1.00 NC GR5 ZP	2
4	1029115	WASHER-LOCK: .31 ZP	2
5	73492	AH233087	1
6	1011303	SCREW-MACHINE RND SLT #10-24 X 1.25	2
7	1026591	NUT-K-LOCK: #10-24 NC GR2 ZP	2
8	306822	GROMMET-DLS SHAFT	1
9	306823	LEVER-DLS	1
10	306825	SUPPORT-DLS SHAFT (NOT SHOWN)	1
11	306826	O-RING (NOT SHOWN)	1
12	306827	SHAFT-DLS	1
14	306828	BALL JOINT ROD END, 1/4"-28 RH	1
15	1011579	NUT-HEX: .25 NF GR2 ZP	1
16	306829	BALL JOINT ROD END, 1/4"-28 LH	1
17	306830	TURNBUCKLE	1
18	306831	BOLT-SHLDR: 3/16" X 1.0" SHLDR L X #8-32	1
19	62617	NUT-NYLOCK: #8-32 GR2 ZP	1
20	306832	BOLT-SHLDR: 1/4" X 1/2" SHLDR L X #10-24	2
21	65695	WASHER-FLAT: .25 SS (IF NEEDED)	1
22	67079	NUT-NYLOCK: #10-24 GR2 ZP	2

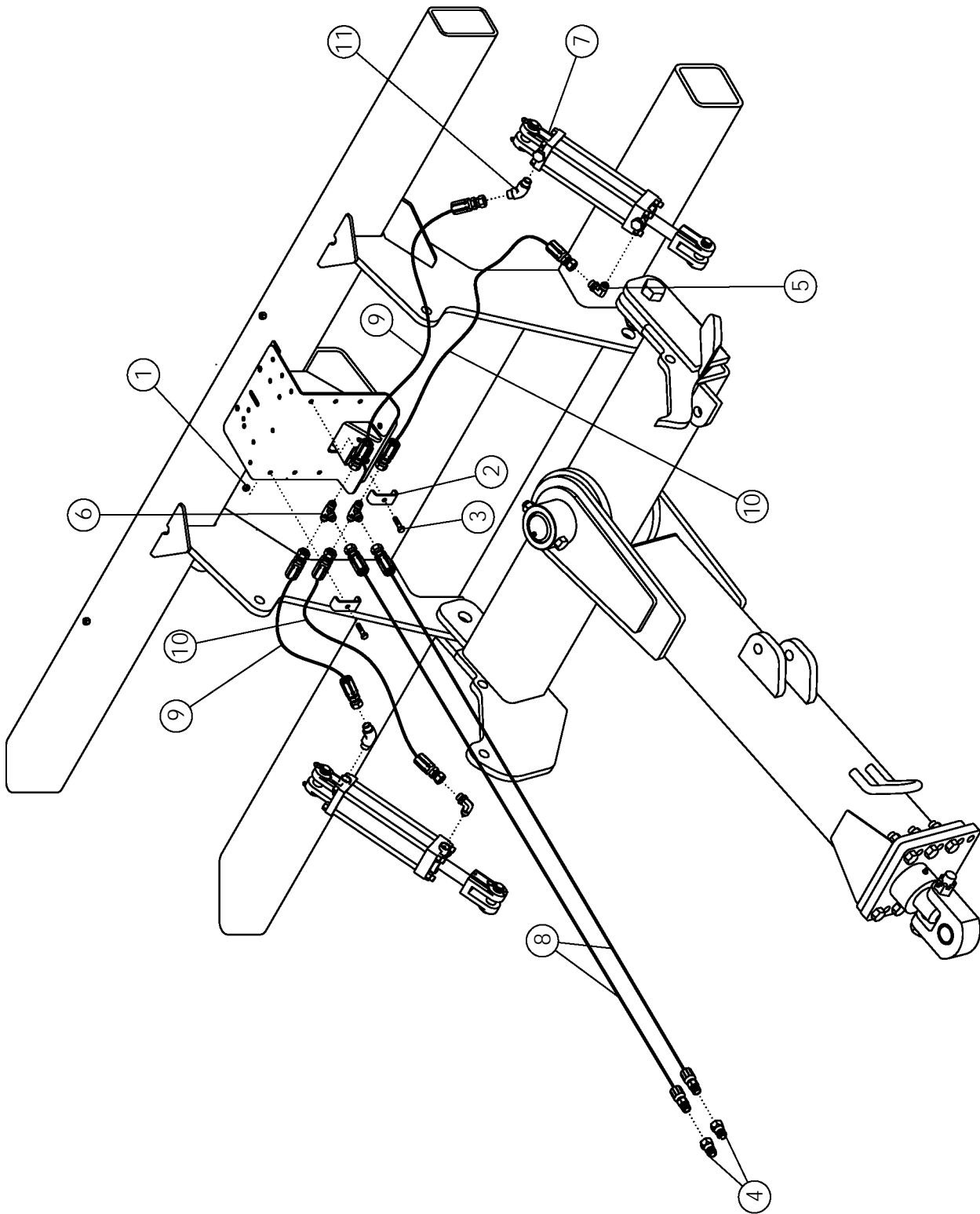



# HITCH HYDRAULICS

ITEM	PART NO.	DESCRIPTION	QTY
1	1016999	NUT-TOPLOCK: .38 NC GR5 ZP	6
2	50714	CLAMP .50 ZP	6
3	1011602	BOLT-HEX: .38 X 1.50 NC GR5 ZP	6
4	36290	PIONEER TIP 8010-15P (#8 ORB)	2
5	58560	FTG-ELBOW: 8MB-8MJ-90	2
6	57667	FTG-TEE: 8MJ-8MJ-8MJ	4
7	62082	CYLINDER-HYDRAULIC 4 X 10" 3000	2
	301315	SEAL KIT FOR 62082 UNIVERSAL	
8	37705	HOSE: .50 X 128 8FJX-8MB	2
9	57676	HOSE: .50 X 031 8FJX-8FJX (6R/8R)	2
	1015221	HOSE: .50 X 040 8FJX-8FJX(12R)	
10	301105	HOSE: .50 X 043 8FJX-8FJX (6R/8R)	2
	35770	HOSE: .50 X 052 8FJX-8FJX (12R)	
11	58515	FTG-ELBOW: 8MB-8MJ-45	2

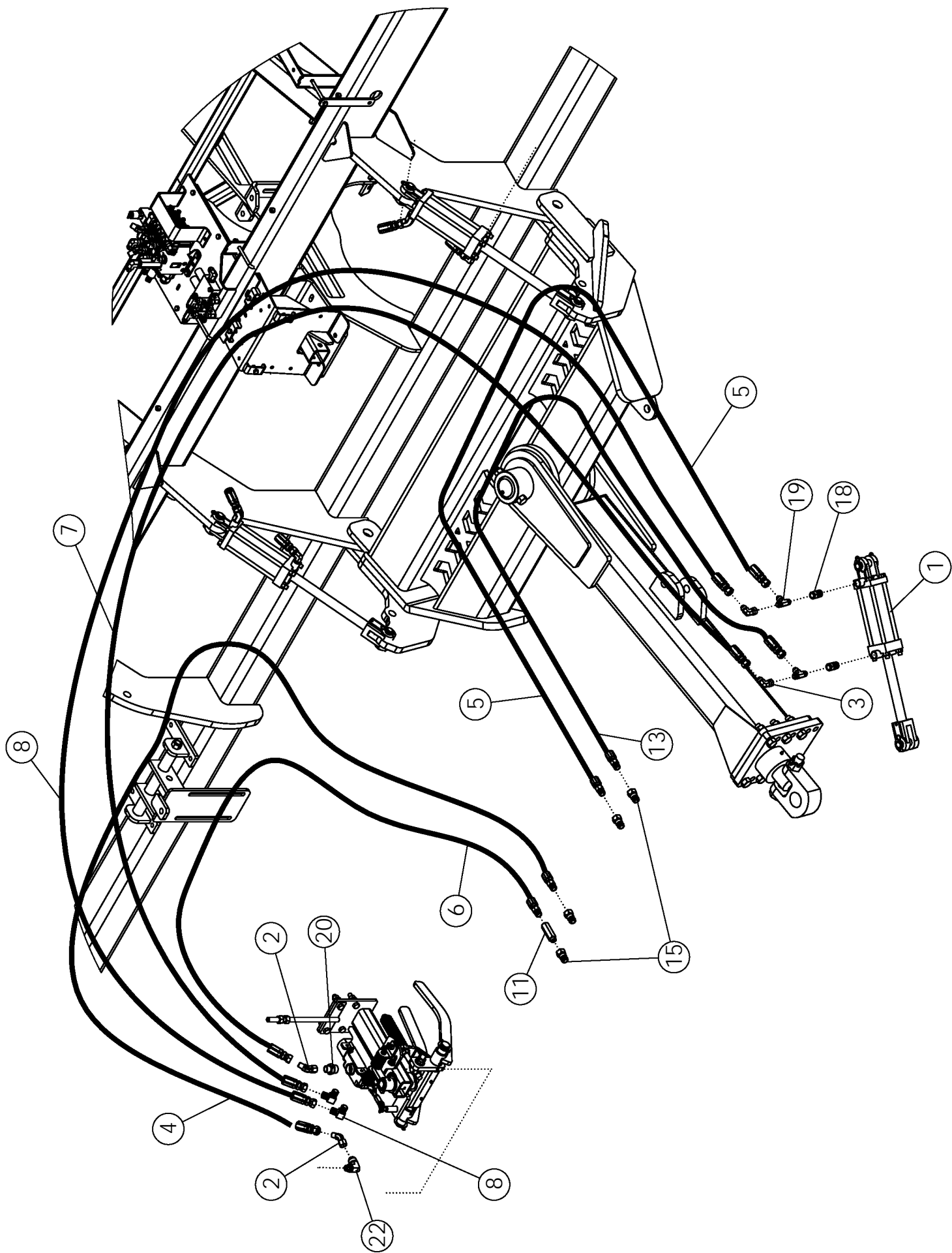

# FRAME MOUNTED ROW FINDER HYDRAULICS

ITEM	PART NO.	DESCRIPTION	QTY
1	58891	CYLINDER-HYDRAULIC 4 X 8" 3000	1
	301315	SEAL KIT UNIVERSAL	
2	57663	FTG-ELBOW: 8MJ-8FJX-45	2
3	57668	FTG-ELBOW: 8MJ-8FJX 90	2
4	301642	HOSE: .50 X 322 8MB-8FJX	1
5	301645	HOSE: .50 X 215 8MB-8FJX	1
6	301641	HOSE: .50 X 314 8MB-8FJX	1
7	301644	HOSE: .50 X 295 8FJX-8FJX	1
8	301643	HOSE: .50 X 286 8FJX-8FJX	1
9	301647	HOSE: .50 X 143 8MB-8FJX	2
10	1015221	HOSE: .50 X 040 8FJX-8FJX(12R)	2
11	300070	CHECK VALVE 8MB-8FB FLOW F-->M (FC-08R)	1
12	1018115	HOSE: .50 X 030 8FJX-8FJX (12R)	2
13	301646	HOSE: .50 X 223 8MB-8FJX	1
14	301648*	HOSE: .38 X 160 8MB-6FJX (NOT SHOWN)	1
15	36290	PIONEER TIP 8010-15P (#8 ORB)	4
16	58195	FTG-ADAPTER: 10MB-8MJ	1
17	65901	FTG-ELBOW: 10MB-8MJ-90	1
18	56941	FTG-ADAPTER: 8MB-8FJX	2
19	57667	FTG-TEE: 8MJ-8MJ-8MJ	2
20	58195	FTG-ADAPTER: 10MB-8MJ	1
21	58560	FTG-ELBOW: 8MB-8MJ-90	2
22	57664	FTG-ELBOW: 12MP-8MJ-90	1

\*USED WITH ADC VALVE CONTROL BOX

**\*\*IMPORTANT\*\* ITEM 11 (PN: 300070-CHECK VALVE) MUST BE INSTALLED AS SHOWN PER THE DIAGRAM, TO PREVENT PREMATURE ROWFINDER VALVE FAILURE.**

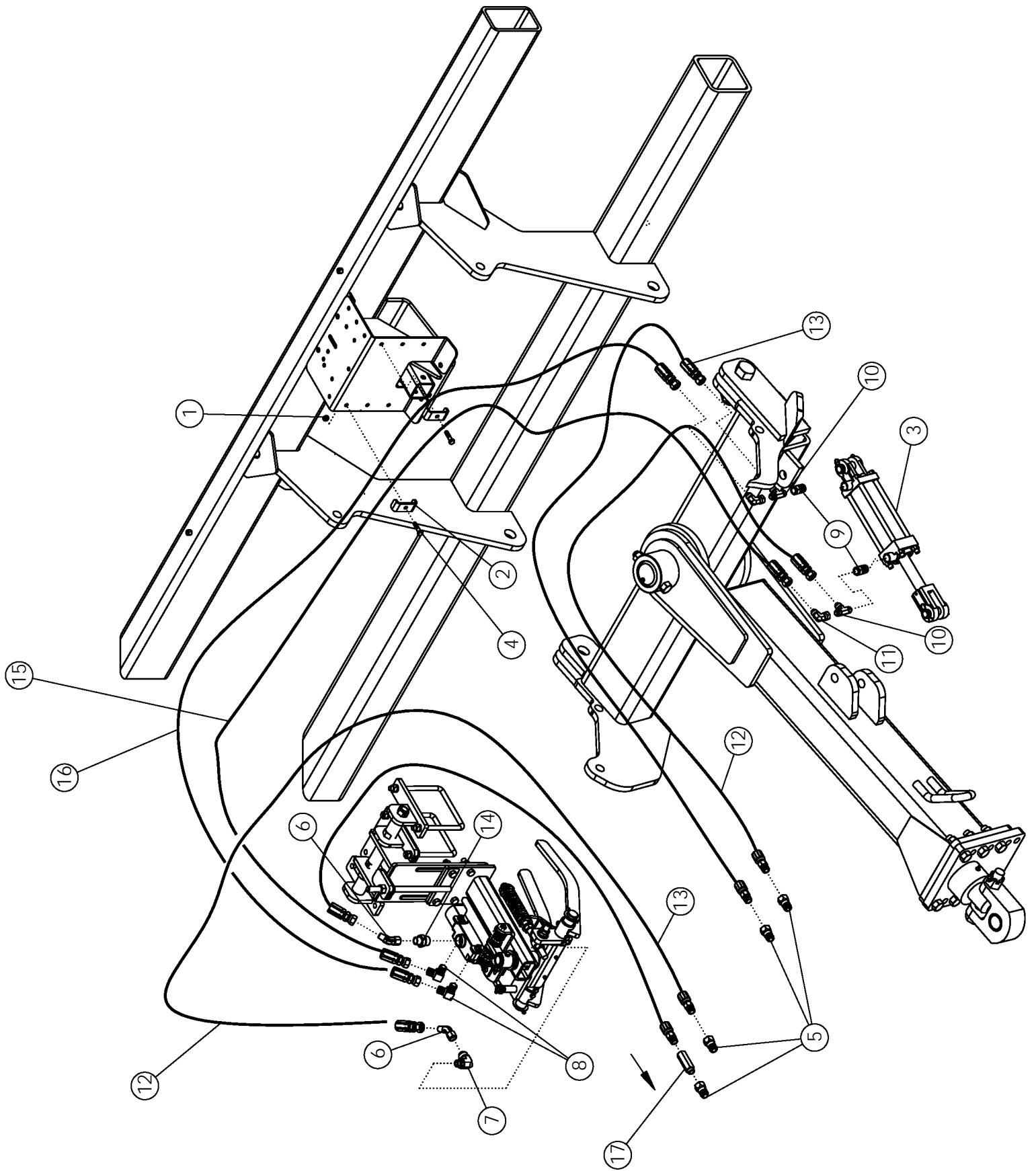

# HITCH MOUNTED ROW FINDER HYDRAULICS

ITEM	PART NO.	DESCRIPTION	QTY
1	1016999	NUT-TOPLOCK: .38 NC GR5 ZP	6
2	50714	CLAMP .50 ZP	6
3	58891	CYLINDER-HYDRAULIC 4 X 8" 3000	1
	301315	SEAL KIT FOR 58991 UNIVERSAL	
4	1011602	BOLT-HEX: .38 X 1.50 NC GR5 ZP	6
5	36290	PIONEER TIP 8010-15P (#8 ORB)	6
6	57663	FTG-ELBOW: 8MJ-8FJX-45	1
7	65901	FTG-ELBOW: 10MB-8MJ-90	2
8	58560	FTG-ELBOW: 8MB-8MJ-90	4
9	56941	FTG-ADAPTER: 8MB-8FJX	2
10	57667	FTG-TEE: 8MJ-8MJ-8MJ	4
11	57668	FTG-ELBOW: 8MJ-8FJX 90	2
12	300039	HOSE: .50 X 184 8MB-8FJX	2
13	66200	HOSE: .50 X 188 8MB-8FJX	2
14	58195	FTG-ADAPTER: 10MB-8MJ	1
15	57672	HOSE: .50 X 098 8FJX-8FJX	1
16	57673	HOSE: .50 X 096 8FJX-8FJX	1
17	300070	CHECK VALVE 8MB-8FB FLOW F-->M (FC-08R)	1

**\*\*IMPORTANT\*\* ITEM 17 (PN: 300070-CHECK VALVE) MUST BE INSTALLED AS SHOWN PER DIAGRAM, TO PREVENT PREMATURE ROWFINDER VAVE FAILURE.**

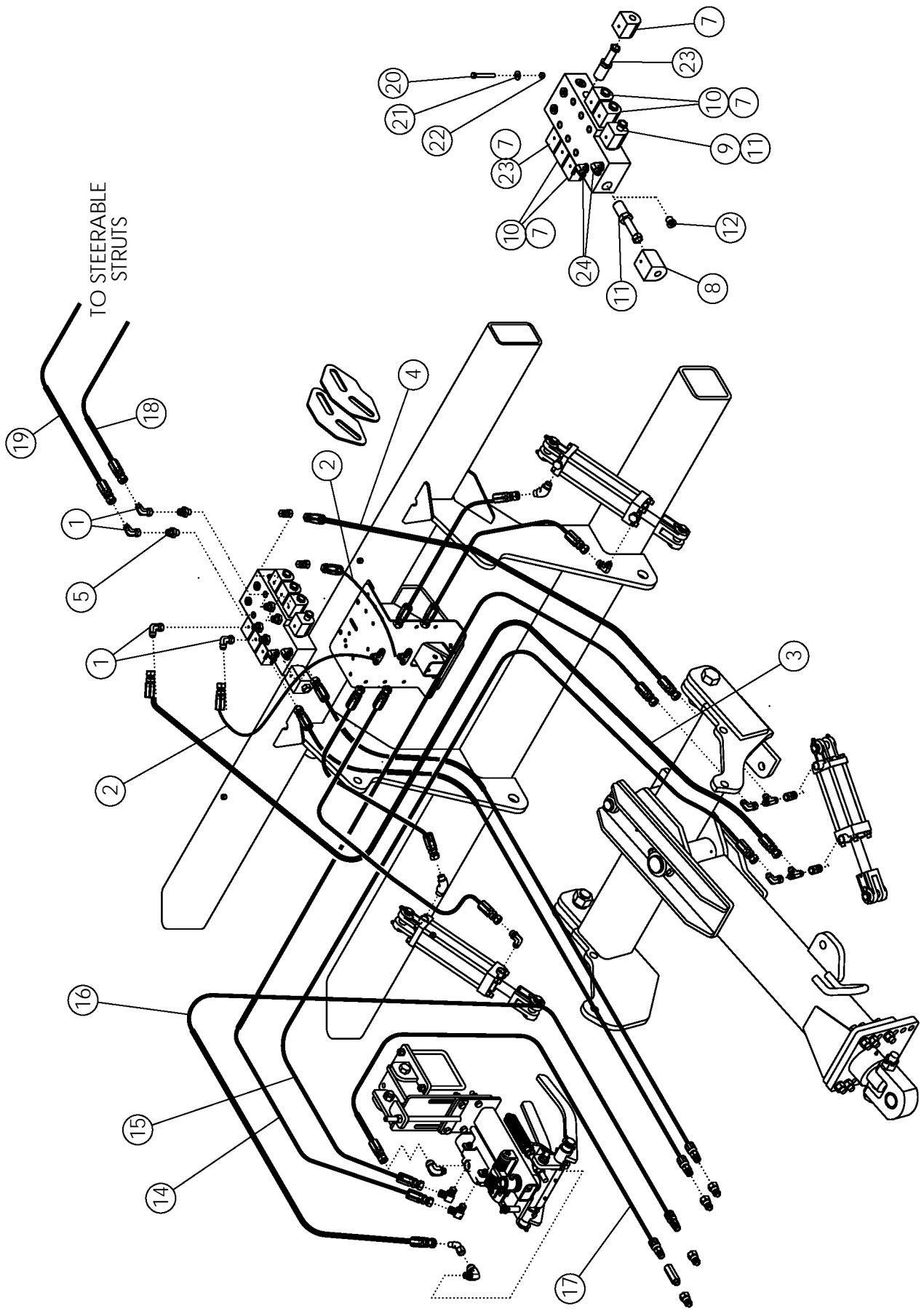

### 3 BANK VALVE W/TOGGLE

ITEM	PART NO.	DESCRIPTION	QTY
1	57668	FTG-ELBOW: 8MJ-8FJX 90	6
2	57677	HOSE: .50 X 021 8FJX-8FJX	2
3	64087	HOSE: .50 X 070 8FJX-8FJX	1
4	57012	HOSE: .50 X 058 8FJX-8FJX	1
5	62024	FTG-ADAPTER: 6MB-8MJ	6
6	69425	VALVE-3BANK	1
7	301280*	COIL-SMALL	6
8	301279*	COIL-LARGE	2
9	62866	CARTRIDGE	1
10	62867	CARTRIDGE	4
11	62868*	CARTRIDGE	1
12	301732*	PLUG-CAVITY	1
13	301277	HARNES-FASSE VALVE (3 BANK) (NOT SHOWN)	1
14	57673	HOSE: .50 X 096 8FJX-8FJX	1
15	57672	HOSE: .50 X 098 8FJX-8FJX	1
16	57669	HOSE: .50 X 153 8MP-8FJX	1
17	57671	HOSE: .50 X 163 8MP-8FJX	1
18	58378	HOSE: .50 X 182 8FJX-8FJX	1
19	58377	HOSE: .50 X 172 8FJX-8FJX	1
20	1019828	BOLT-HEX: .38 X 2.75 NC GR5 ZP	2
21	1011828	WASHER-FLAT: .38 ZP	8
22	1016999	NUT-TOPLOCK: .38 NC GR5 ZP	2
23	69632	CARTRIDGE-FASSE DUAL POPPET	2
24	58560	FTG-ELBOW: 8MB-8MJ 90	2

\*IMPORTANT: VALVE (69425) IS SHIPPED OPEN CENTER. TO CONVERT TO CLOSED CENTER, REMOVE COIL AND CARTRIDGE (301279 & 62868) FROM THE END OF THE VALVE BODY AND REPLACE WITH CAVITY PLUG (301732) WHICH IS SUPPLIED WITH THE VALVE.





# SELF-CONTAINED HYDRAULIC SYSTEM

ITEM	PART NO.	DESCRIPTION	QTY
1	1027461	NUT-TOPLOCK: .50 NC GR5 ZP	6
2	1016999	NUT-TOPLOCK : .38 NC GR5 ZP	7
3	59880	BRACKET-FLOW CONTROL	1
4	58985	VALVE-FLOW CONTROL 3/4" FP	2
	64414	SEAL KIT FOR 58985	
5	59042	FTG-ADAPTER: 12MP-12MJ	5
6	59041	FTG-ELBOW: 12MJ-12FJX 90	5
7	59043	FTG-ADAPTER: 10MB-12MJ	4
8	63799	FTG-ADAPTER: 12MP-12FJX	1
9	63800	FTG-CROSS: 12MJ	1
10	59044	FTG-ELBOW: 12MP-12MJ 90	1
11	59888	FTG-TEE: 12MJ-12FJX-12MJ	3
12	68179	VALVE-CHECK: 12MJ-12MJ	1
13	1011602	BOLT-HEX: .38 X 1.50 NC GR5 ZP	3
14	59182	BRACKET-HOSE ZP	2
15	1011586	WASHER-LOCK: .38 ZP	3
16	1011584	WASHER-FLAT: SAE .50 ZP	6
17	63753	CLAMP-HOSE: .75 ZP	6
18	1011725	BOLT-HEX: .38 X 2.00 NC GR5 ZP	3
19	59184	BRACKET-HOSE ZP	1
20	65658	U-BOLT: .50 X 3.00 X 2.06 X 3.00	1
21	59881	BRACKET-BOLT PLATE	2
22	1013239	BOLT-HEX: .38 X 3.00 NC GR5 ZP	4
23	1032285	BOLT-HEX: .25 X 2.50 NC GR5 ZP	2
24	1020416	WASHER-FLAT: .25 ZP	14
25	1030946	NUT-TOPLOCK: .25 NC GR5 ZP	4
26	64101	HOSE: .75 X 072 12FJX-12FJX	2
27	68167	HOSE: .75 X 055 12FJX-12FJX	1
28	63798	HOSE: .75 X 21 12FJX-12FJX	1
29	59800	HOSE: .75 X 164 12FJX-12FJX	1
30	59805	HOSE: .75 X 180 12FJX-12FJX	2
31	68437	HOSE: .50 X 014 12FJX-12FJX	2
32	59892	HOSE: .75 X 208 12FJX-12FJX	1
33	59801*	HOSE: .75 X 98 12FJX-12FJX	1

\* (NOT SHOWN) USED WITH WHEEL CLEANER OPTION

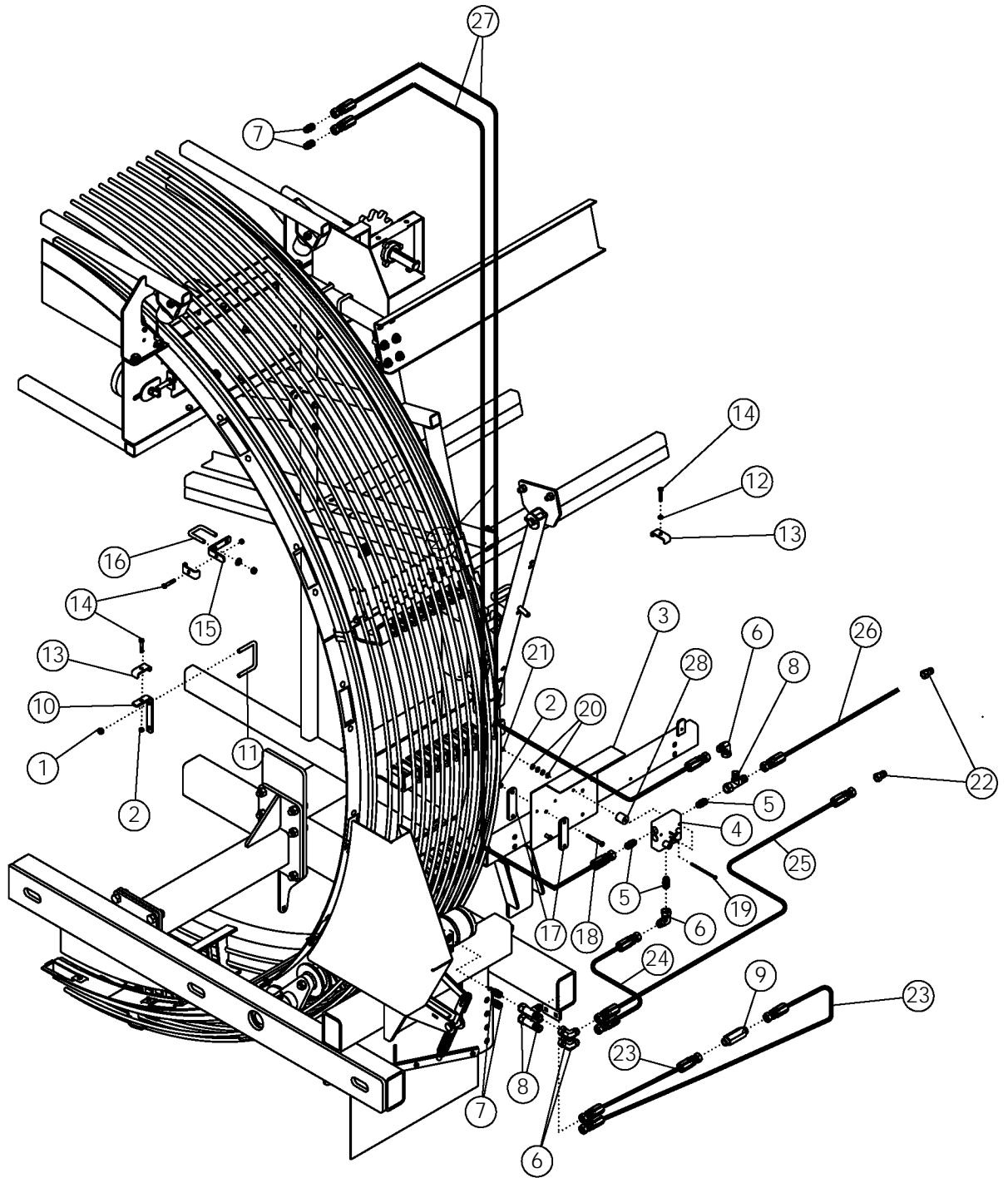

# TRACTOR HYDRAULIC DRIVE

ITEM	PART NO.	DESCRIPTION	QTY
1	1027461	NUT-TOPLOCK: .50 NC GR5 ZP	6
2	1016999	NUT-TOPLOCK : .38 NC GR5 ZP	7
3	69020	BRACKET-FLOW CONTROL SMALL	1
4	58985	VALVE-FLOW CONTROL 3/4" FP	1
	64414	SEAL KIT FOR 58985	
5	59042	FTG-ADAPTER: 12MP-12MJ	3
6	59041	FTG-ELBOW: 12MJ-12FJX-90	4
7	59043	FTG-ADAPTER: 10MB-12MJ	4
8	59888	FTG-TEE: 12MJ-12FJX-12MJ	3
9	68179	VALVE-CHECK: 12MJ-12MJ	1
10	59182	BRACKET-HOSE ZP	2
11	54653	U-BOLT: .50 X 3.25 X 4.00 X 3.25	2
12	1011586	WASHER-LOCK: .38 ZP	5
13	63753	CLAMP-HOSE .75 ZP	8
14	1011725	BOLT-HEX: .38 X 2.00 NC GR5 ZP	8
15	59184	BRACKET-HOSE ZP	1
16	65658	U-BOLT: .50 X 3.00 X 2.06 X 3.00	1
17	59881	BRACKET-BOLT PLATE	4
18	58176	BOLT-HEX: .38 X 3.50 NC GR5 ZP	4
19	1030776	BOLT-HEX: .25 X 4.00 NC GR5	2
20	1020416	WASHER-FLAT: .25 ZP	8
21	1030946	NUT-TOPLOCK: .25 NC GR5 ZP	2
22	36290	PIONEER TIP	2
23	68437	HOSE: .50 X 14 12FJX-12FJX	2
24	59071	HOSE: .75 X 60 12FJX-12FJX	1
25	302337	HOSE: .63 X 318 12FJX-10MB	1
26	302338	HOSE: .63 X 252 12FJX-10MB	1
27	59892	HOSE: .75 X 208 12FJX-12FJX	2
28	59463	SPACER ZP	2

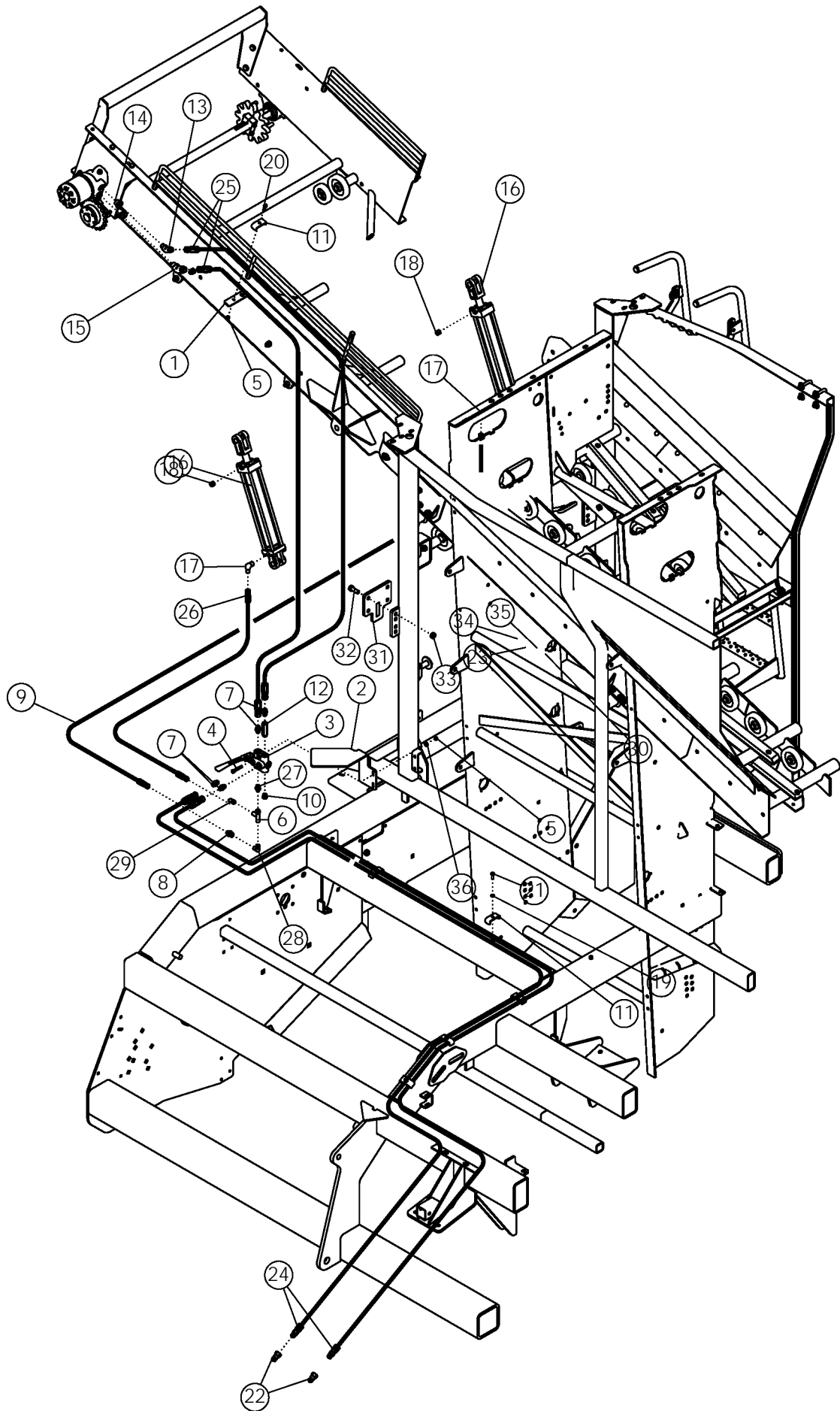

# TANK HYDRAULICS

ITEM	PART NO.	DESCRIPTION	QTY
1	54825	BRACKET-HOSE ZP	2
2	62904	GUARD-SELECTOR VALVE	1
3	58470	VALVE-SELECTOR	1
4	59390	BOLT-HEX: .38 X 2.25 NC GR5 ZP	2
5	1016999	NUT-TOPLOCK: .38 NC GR5 ZP	4
6	56231	FTG-TEE: 6MJ-6FJX-6MJ	1
7	56226	FTG-ADAPTER: 8MB-8MJ	4
8	300072	FITTING-RESTRICTOR (6MJ-6FJ R 1/16)	1
9	68163	HOSE: .38 X 96 6FJX-6FJX	1
10	56190	FTG-PLUG: 8MB	1
11	50714	CLAMP 1/2" ZP	10
12	300070	VALVE-CHECK: 8MB-8FB FLOW F-->M	1
13	58515	FTG-ELBOW: 8MB-8MJ-45	1
14	300069	FTG-ADAPTER: 8FB-10MB	1
15	56229	FTG-ELBOW: 10MB-8MJ-45	1
16	58889	CYLINDER-HYD 2.5 X 16	2
17	58557	FTG-ELBOW: 8MB-6MJ 90	2
18	58547	FTG-PLUG: 8MB BREATHER	2
19	1011586	WASHER-LOCK: .38 ZP	6
20	1011602	BOLT-HEX: .38 X 1.50 NC GR5 ZP	2
21	1011600	BOLT-HEX: .38 X 1.00 NC GR5 ZP	6
22	36290	PIONEER TIP 8010-15P (#8 ORB)	2
23	50779	HOSE-CLAMP	2
24	1015804	HOSE: .50 X 240 8FJX-8MB	2
25	56235	HOSE: .50 X 155 8FJX-8FJX	2
26	63897	HOSE: .38 X 32 6FJX-6FJX	1
27	66624	FTG-ADAPTER: 6MJ-8MB	1
28	57897	FTG-ELBOW: 6MJ-6FJX-90	1
29	301538	FTG-ELBOW: 6MJ-6FJX-45	1
30	1030946	NUT-TOPLOCK: .25 NC GR5 ZP	2
31	301298	WLDMT-CYLINDER LUG	2
32	1013918	BOLT-HEX .63 X 1.750 NC GR5 ZP	8
33	1016595	NUT-TOPLOCK: .63 NC GR5 ZP	8
34	1011595	BOLT-HEX: .25 X .75 NC GR5 ZP	2
35	1020416	WASHER-FLAT: .25 ZP	2
36	1011828	WASHER-FLAT .38 ZP	2

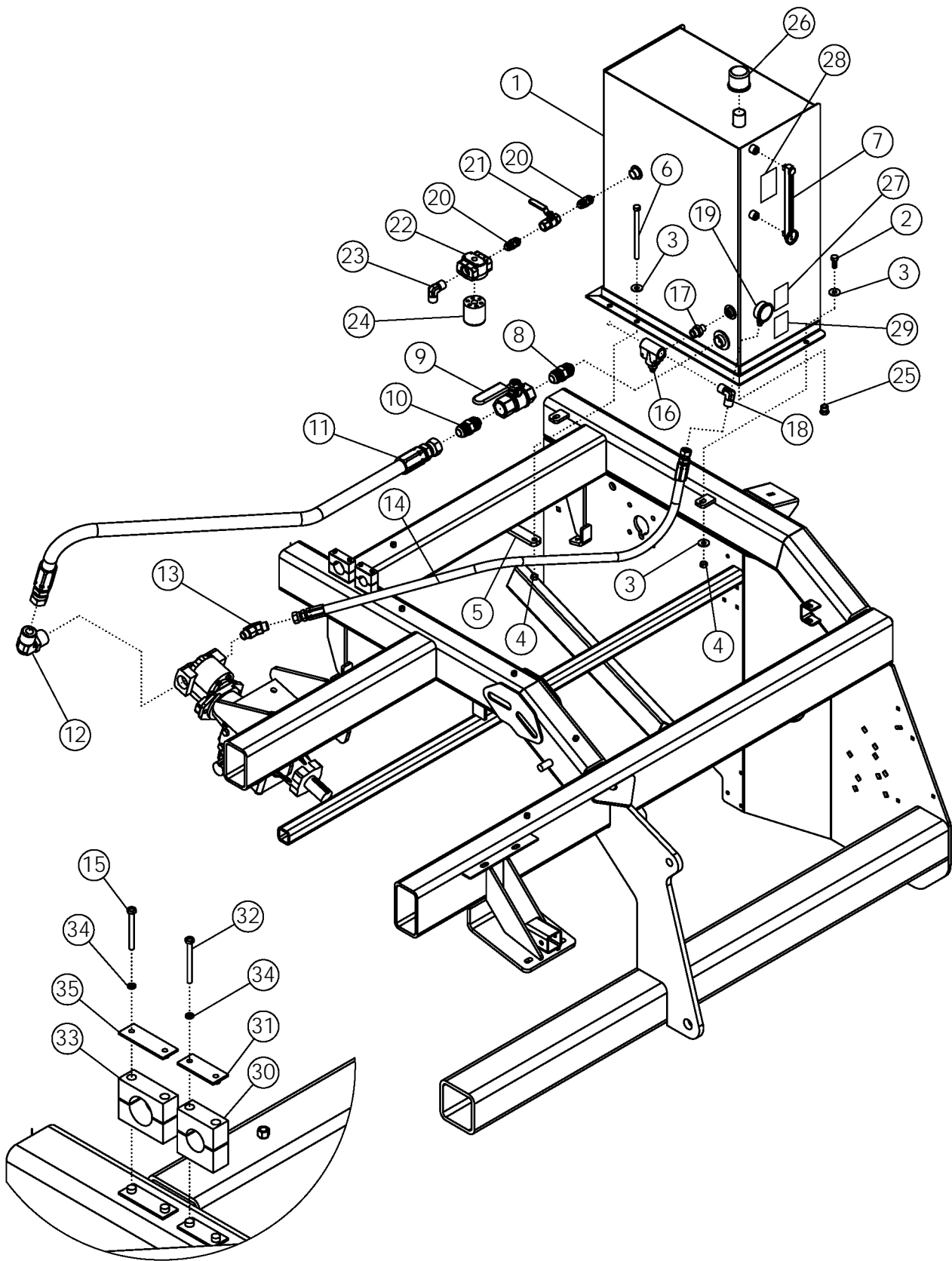

# HYDRAULIC TANK

ITEM	PART NO.	DESCRIPTION	QTY
1	58079	HYDRAULIC TANK-PAINTED	1
2	1011606	BOLT-HEX: .50 X 1.25 NC GR5 ZP	2
3	1014443	WASHER-FLAT: .50 ZP	4
4	1027461	NUT-TOPLOCK: .50 NC GR5 ZP	4
5	58204	BAR - BOLTING	1
6	1011611	BOLT-HEX: .50 X 3.00 NC GR5 ZP	2
7	58914	GAUGE-LEVEL & TEMP	1
8	58978	FTG-ADAPTER: 20MP-20MP	1
9	58979	VALVE-BALL: 20FP-20FP	1
10	62209	FTG-ADAPTER: 20MP-20MJ	1
11	68178	HOSE: 1.25 X 074 20FJX-20FJX	1
12	58980	FTG-ELBOW: 24MB-20MJ-90	1
13	62212	FTG-ELBOW: 16MB-12MJ-45	1
14	68166	HOSE: .75 X 068 12FJX-12FJX	1
15	1032285	BOLT-HEX: .25 X 2.50 NC GR5 ZP	2
16	58190	VALVE-RELIEF	1
17	58466	FTG-ADAPTER: 12MP-8MP	1
18	58983	FTG-ELBOW: 12MP-12MJ-90 W/.25" FP	1
19	62518	GAUGE-PRESSURE: 1/4"MP 3000 PSI	1
20	58196	FTG-ADAPTER: 12MP-12MP	2
21	59165	VALVE-BALL 3/4FP - 3/4FP	1
22	58690	FILTER HEAD	1
23	59044	FTG-ELBOW: 12MP-12MJ-90	1
24	58691	FILTER-HYDRAULIC	1
25	55718	FTG-PLUG: 8MB	1
26	58197	CAP-FILLER	1
27	62964	DECAL-WARNING	1
28	64428	DECAL-HYD TANK SPECS	1
29	64429	DECAL-WARNING BALL VALVE	1
30	64645	CLAMP-STAUFF 6445PPH (2 HALVES)	1
31	64646	PLATE-COVER DP5	1
32	1032287	BOLT-HEX: .25 X 2.75 NC GR5 ZP	2
33	64612	CLAMP-STAUFF 5278PPH (2 HALVES)	1
34	1013242	WASHER-LOCK: .25 ZP	4
35	64613	PLATE-COVER DP6	1

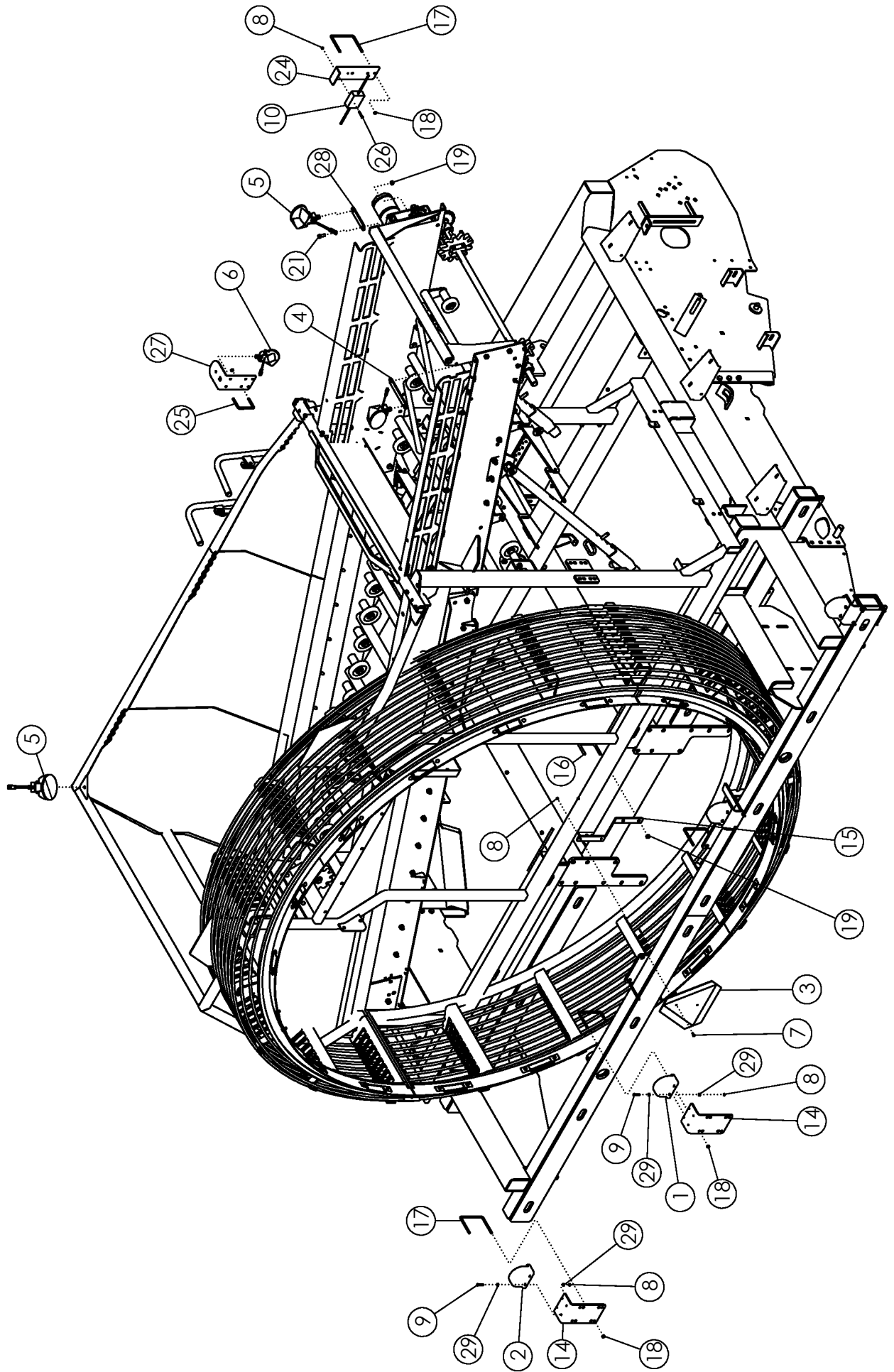



## LIGHT KIT HD

ITEM	PART NO.	DESCRIPTION	QTY
1	305218	LIGHT-RED LAMP SAE	2
2	305217	LIGHT-AMBER LAMP SAE	2
3	65329	SIGN-SMV ASAE	1
4	300326	PLATE-LIGHT MOUNT BOOM	2
5	301293	LIGHT-GROTE 2000 OVAL FLOOD	3
6	301294	LIGHT-ROTE T26 NEAR FLOOD	2
7	1011595	BOLT-HEX: .25 X .75 NC GR5 ZP	2
8	1030946	NUT-TOPLOCK: .25 NC GR5 ZP	20
9	1019550	BOLT-HEX: .25 X 1.50 NC GR5 ZP	16
10	305216	HARNESS-FLASHER MODULE	1
11	301494	HARNESS-8R HAZARD (NOT SHOWN)	1
12	301495	HARNESS-8R WORK LIGHT (NOT SHOWN)	1
13	62833	CLAMP-ADHESIVE BACKED CABLE (NOT SHOWN)	8
14	64363	BRACKET-LIGHT WHEEL HRV	4
15	64246	MOUNT-SMV SIGN	1
16	54653	U-BOLT: .50 X 3.25 X 4.00 X 3.25	1
17	64364	U-BOLT: .38 X 5.13 X 6.00 X 5.13	9
18	1016999	NUT-TOPLOCK: .38 NC GR5 ZP	26
19	1027461	NUT-TOPLOCK: .50 NC GR5 ZP	4
20	301717	HARNESS-EXTENSION 31" 2 WIRE DEUTWSCH	2
21	1011606	BOLT-HEX: .50 X 1.25 NC GR5 ZP	2
22	1013122	TIE-NYLON CABLE 50# X 15.50"	40
23	301335	HARNESS-HRV 12R MAIN (NOT SHOWN)	1
24	301339	PLATE-LIGHT MODULE MOUNT	1
25	306098	U-BOLT: .375 X 3.00 X 4.00 X 3.00 ZP	4
26	1016853	BOLT-HEX: .25 X 1.75 N GR5 ZP	2
27	300327	PLATE-LIGHT MOUNT BOOM	2
28	300332	PLATE-LIGHT MOUNT BOOM (FRONT)	1
29	0100979	WASHER-FLAT: SAE .25 ZP	32

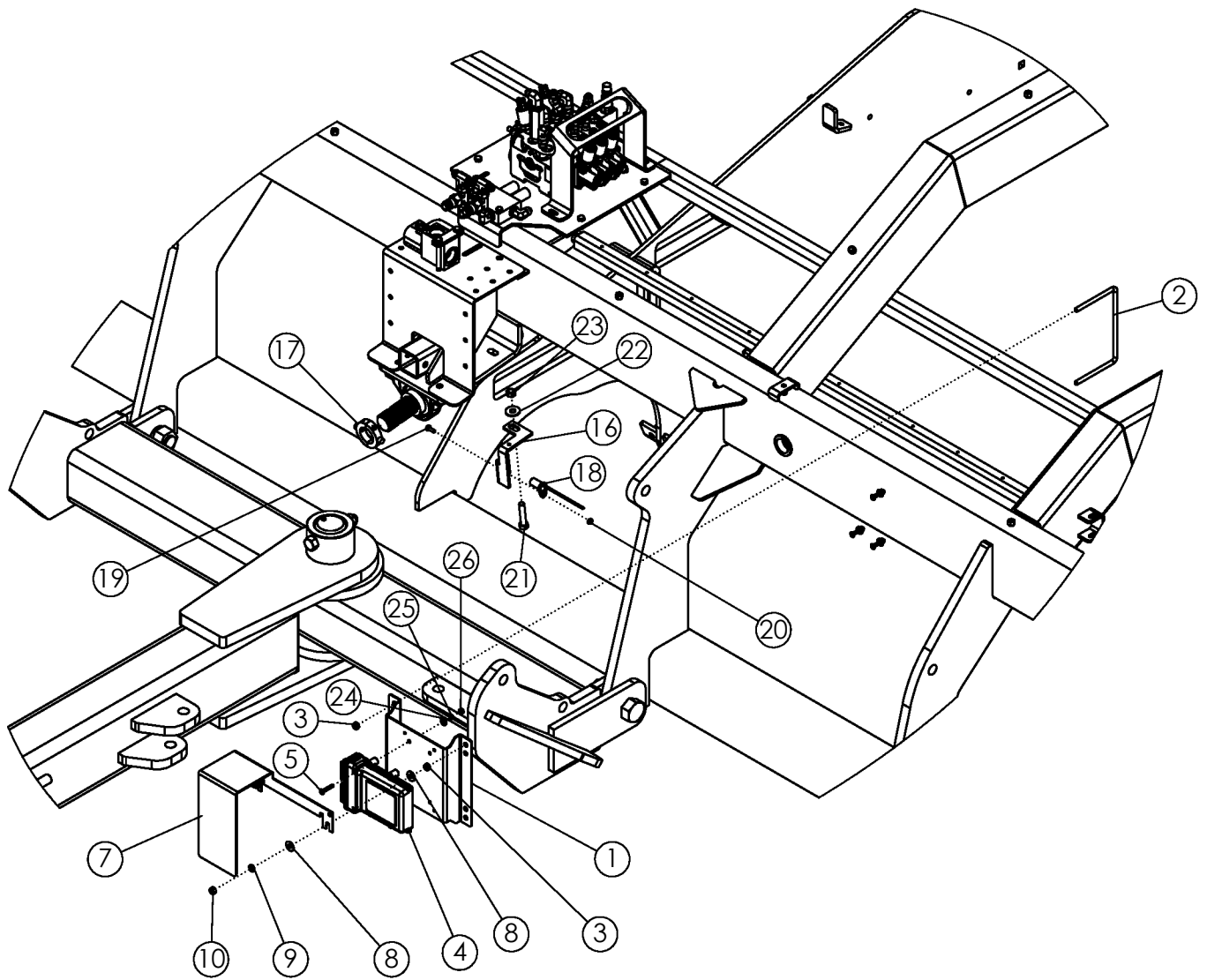

## ADC ELECTRONICS

ITEM	PART NO.	DESCRIPTION	QTY
1	301046	PLATE-MNT CONTROL BOX ADC	1
2	64244	U-BOLT: .375 X 5.13 X 8.00 X 5.13 ZP	2
3	1016999	NUT-TOPLOCK: .38 NC GR5 ZP	4
4	303422	ASSY-ADC ISOBUS CONTROLLER	1
5	53753	SCREW-F-H-S-C: .25-20 X 1.50 GR8	4
6	1026591	NUT-K-LOCK: #10-24 NC GR2 ZP	4
7	301036	PLATE-SHIELD ADC	1
8	1011828	WASHER-FLAT .38 ZP	4
9	1011586	WASHER-LOCK: .38 ZP	2
10	1011576	NUT-HEX: .38 NC GR2 ZP	2
16	301024	BRACKET-PTO SENSOR ADC	1
17	64388	WLDMT-SPLIT COLLAR 1.75"	1
18	301014	SENSOR-PTO ADC	1
19	1011595	BOLT-HEX: .25 X .75 NC GR5 ZP	1
20	1013240	NUT-NYLOCK: .25 NC ZP	1
21	1011610	BOLT-HEX: .50 X 2.50 NC GR5 ZP	1
22	1014443	WASHER-FLAT: .50 ZP	1
23	1027461	NUT-TOPLOCK: .50 NC GR5 ZP	1
24	1020416	WASHER-FLAT: .25 ZP	4
25	1013242	WASHER-LOCK: .25 ZP	4
26	1011587	NUT-HEX: .25 NC GR2 ZP	4

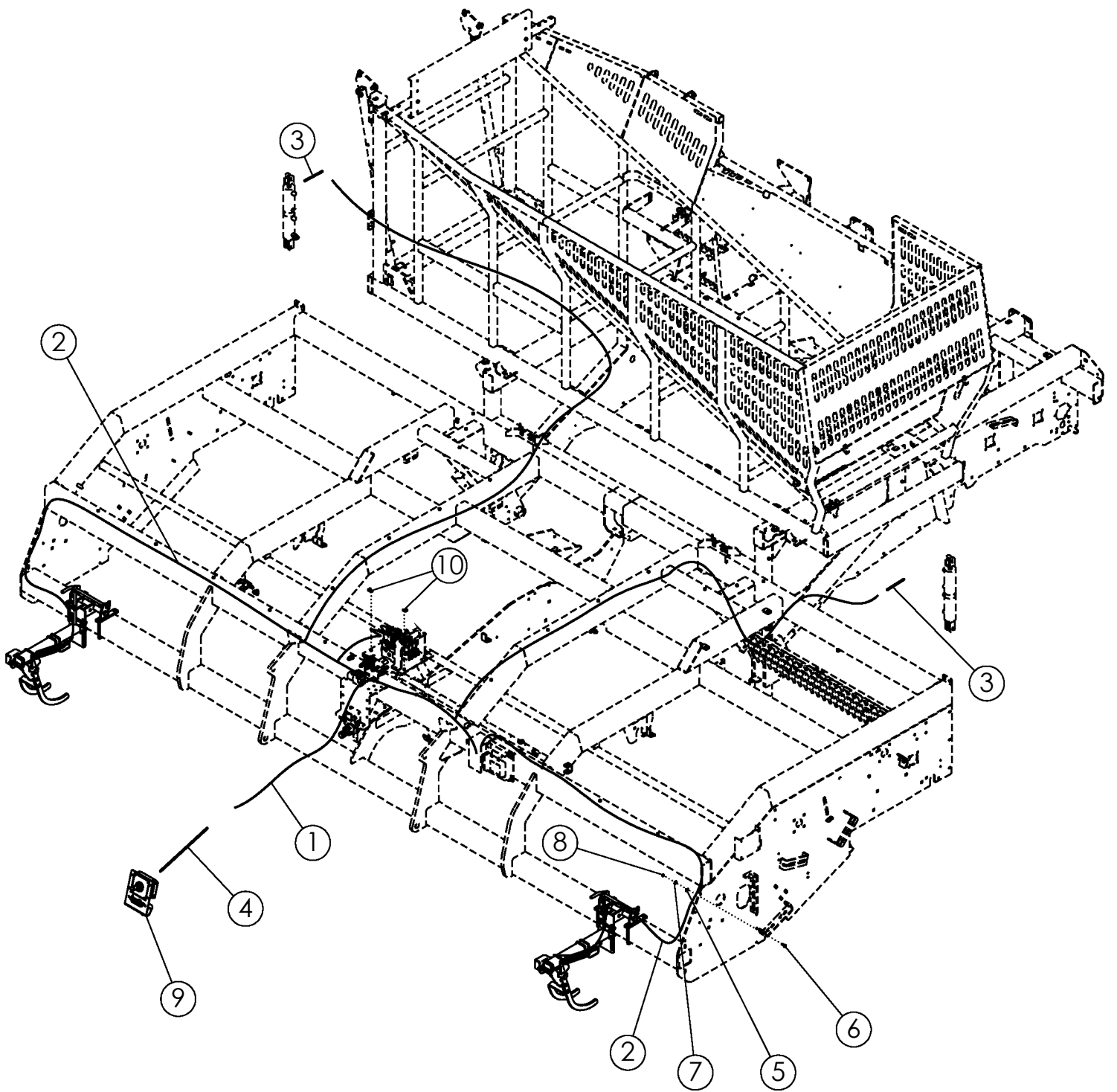

## ACTIVE DEPTH CONTROL ELECTRICAL SCHEMATIC

ITEM	PART NO.	DESCRIPTION	QTY
1	303443	HARNESS-ADC ISOBUS MAIN 2720	1
2	301020	HARNSS-ADC POTENTIOMETER	2
3	73509	HARNESS-CYL SENSOR CONNECTOR	2
4	303444	HARNESS-ADC ISOBUS JOYSTICK EXT	1
5	300249	P-CLIP .38" X .313"	4
6	1016362	BOLT-CRG: .38 X 1.25 NC GR5 ZP	4
7	1011828	WASHER-FLAT: .38 ZP	4
8	1016999	NUT-TOPLOCK: .38 NC GR5 ZP	4
9	303448	KT-JOYSTICK WTH MOUNT	1
10	310919	PCLIP .38" X .375"	2

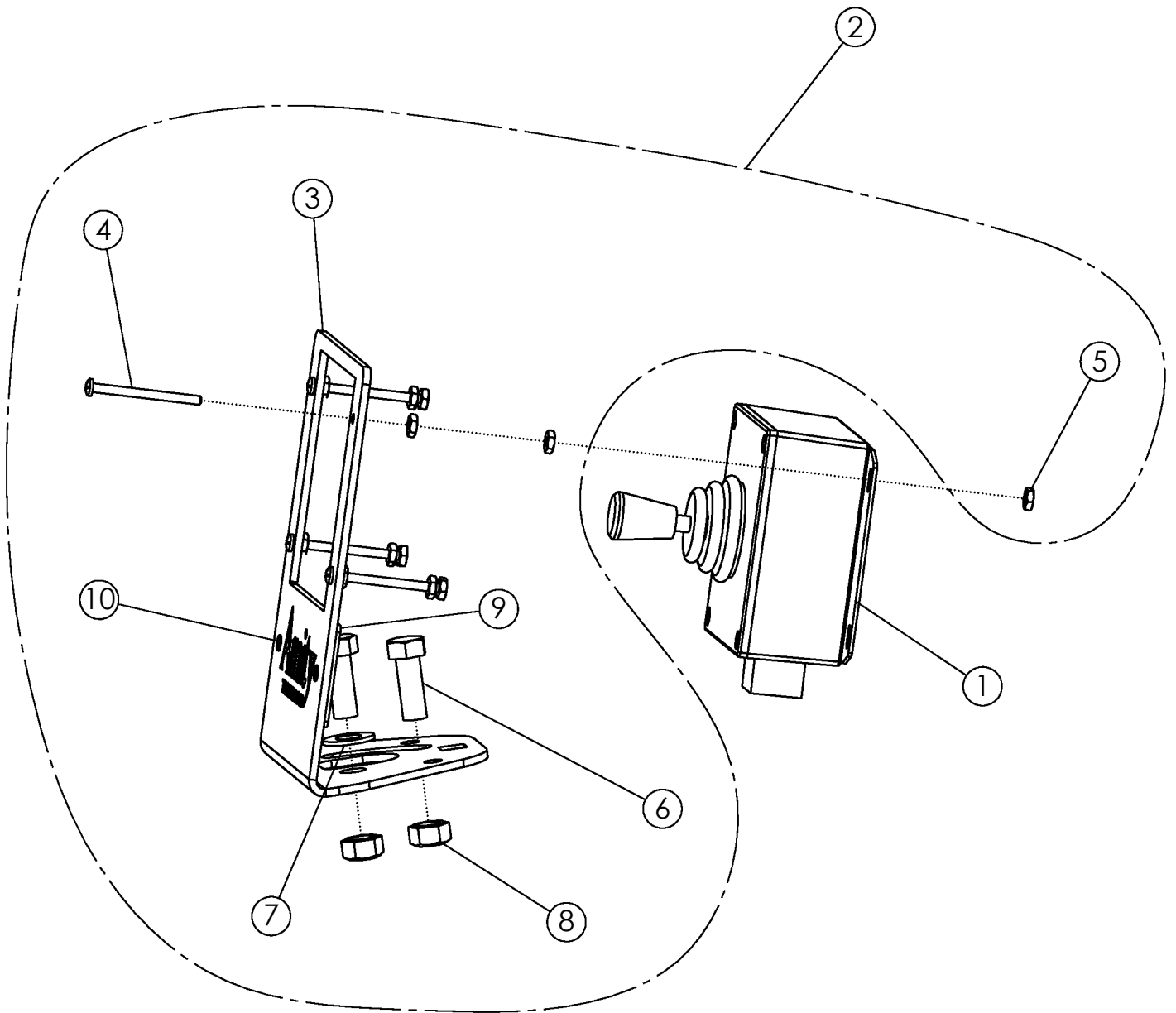



## JOYSTICK WITH MOUNT

ITEM	PART NO.	DESCRIPTION	QTY
1	301151	ASSY-JOYSTICK & ENCLOSURE	1
2	303452	ASSY-JOYSTICK MOUNT	1
3	303451*	PLATE-JOYSTICK MOUNT	1
4	1019992*	SCREW P-H: #6 X 1.75 NC GR5 ZP	4
5	1040448*	#6 NUT	12
6	1011600*	BOLT-HEX: .38 X 1.00 NC GR5 ZP	2
7	1014608*	WASHER-FLAT: SAE .38 ZP	1
8	1016999*	NUT-TOPLOCK: .38 NC GR5 ZP	2
9	311514*	PLATE-JOYSTICK LOGO	1
10	59882*	RIVET-POP: .13 X .31 ZP	2

\*INCLUDED IN 303452

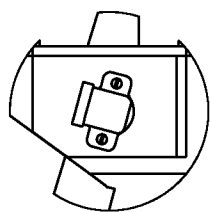
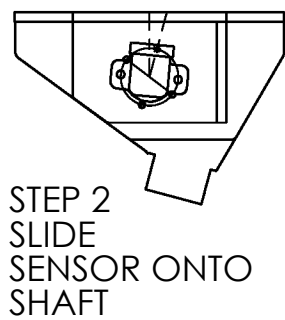
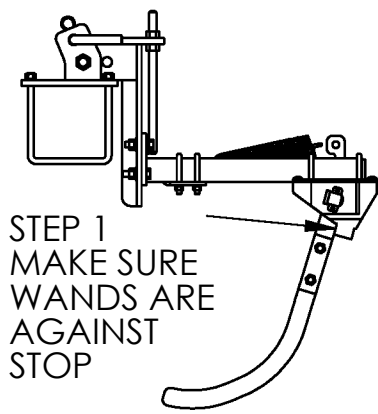

STEP 4  
INSTALL SCREWS  
AND TIGHTEN

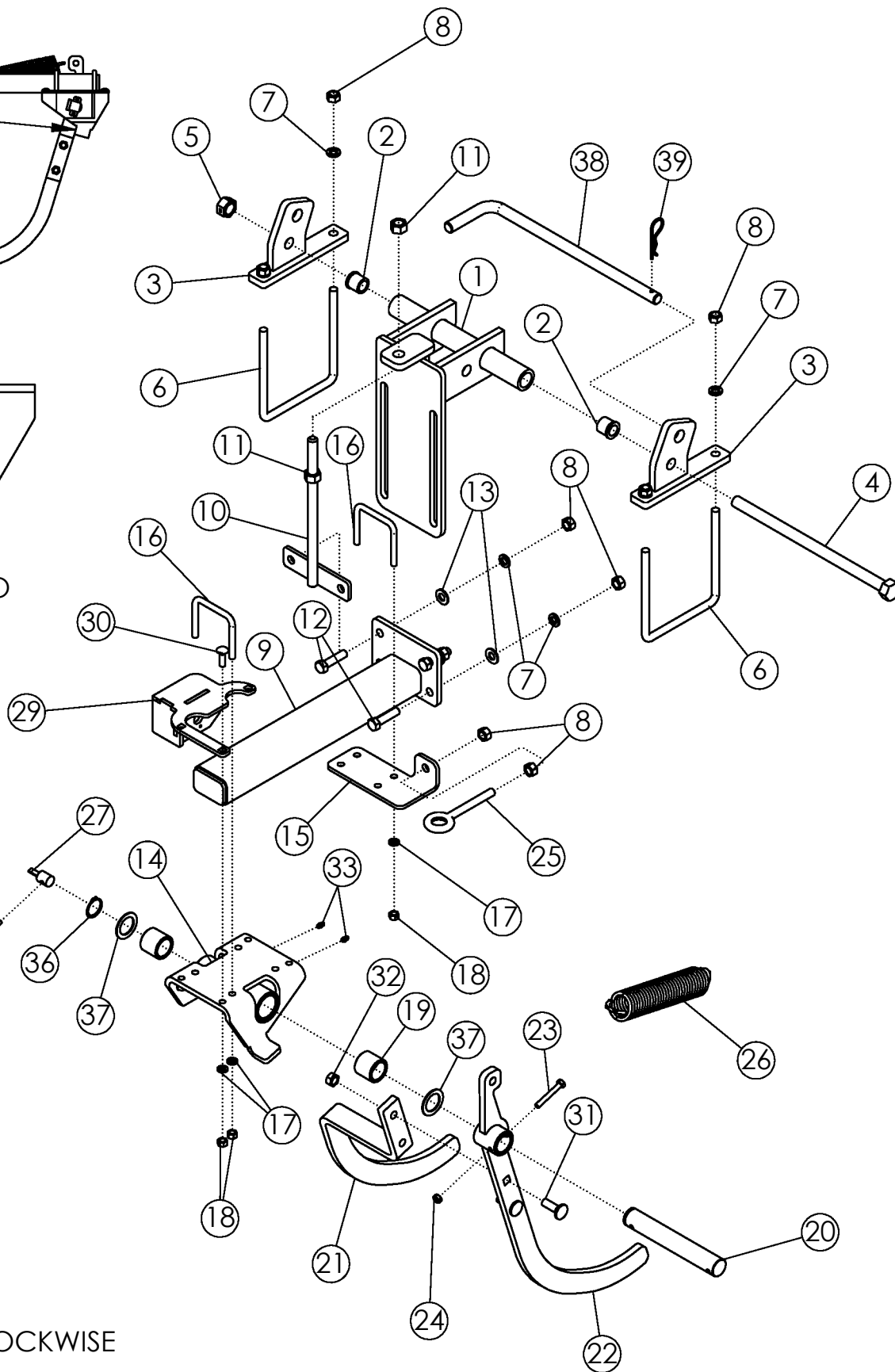



## ACTIVE DEPTH CONTROL WANDS

ITEM	PART NO.	DESCRIPTION	QTY
1	63661	WLDMT-MOUNTING BRACKET	1
2	52654	BUSHING-FLANGE	2
3	300214	WLDMT-MOUNTING SUPPORT ADC NARROW	2
4	63664	BOLT-HEX: .75 X 14.00 NC GR5 ZP	1
5	1013537	NUT-CENTERLOCK: .75 NC ZP	1
6	53984	U-BOLT 1/2 X 7 X 6 X 7	2
7	1011581	WASHER-LOCK: .50 ZP	8
8	1011577	NUT-HEX: .50 NC ZP	10
9	300216	WLDMT-ADC ARM 8R	1
	73474	WLDMT-ADC ARM 12R	
10	62882	WLDMT-TIGHTENER 11.125" ZP	1
11	1011578	NUT-HEX: .63 NC GR2 ZP	2
12	1011609	BOLT-HEX: .50 X 2.00 NC GR5 ZP	4
13	1011584	WASHER-FLAT: SAE .50 ZP	4
14	300218	WLDMT-ADC MAIN 8R/12R	1
15	73490	PLATE-ADC BOLT EYELET	1
16	73491	U-BOLT .375 X 3.00 X 3.063 X 3.000	4
17	1011586	WASHER-LOCK: .38 ZP	11
18	1011576	NUT-HEX: .38 NC GR2 ZP	11
19	56939	BUSHING-BRONZE	2
20	301244	SHAFT-ADC B 8R/12R	1
21	300228	PLATE-WAND SENSOR SIDE	1
22	73475	WLDMT-WAND SPRING SIDE	1
23	301258	BOLT-HEX: .31 X 2.25 NC GR8 ZP	1
24	1030700	NUT-TOPLOCK: .31 NC GR5 ZP	1
25	52306	BOLT-EYE	1
26	53159	SPRING	1
27	73487	SHAFT-ADC A ZP	1
28	73489	BAR-ADC PIN	1
29	300224	WLDMT-ADC SENSOR HOUSING 8R/12R	1
30	1016362	BOLT-CRG: .38 X 1.25 NC GR5 ZP	3
31	1011660	BOLT-CRG: .50 X 1.50 NC GR5 ZP	2
32	1027461	NUT-TOPLOCK: .50 NC GR5 ZP	2
33	1011748	ZERK-GREASE: .25UNF STRAIGHT	2
34	73492	SENSOR-ROTARY POSITION (JD: AH233087)	1
35	1011304	SCREW-MACHINE RND SLT #10-32 X 1.25	2
36	301058	SNAP-RING 1.250"	1
37	55206	BUSHING-MACH: 1.25 NR 14GA	1 OR 2
38	301267	ROD-WAND LOCK	1
39	1029164	PIN-HAIR: .19 X 3.00 ZP	1

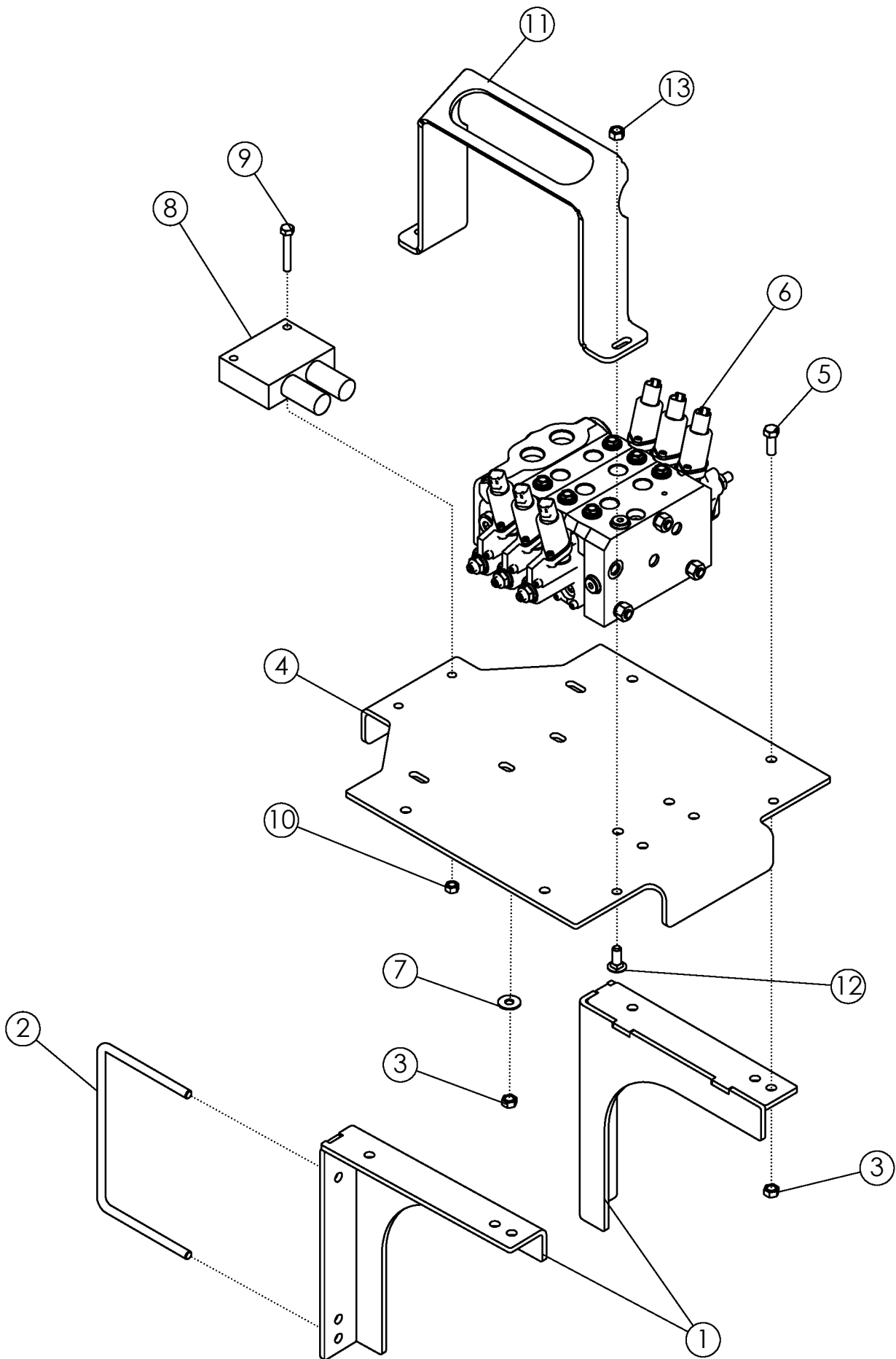

## ADC HYDRAULIC COMPONENTS

ITEM	PART NO.	DESCRIPTION	QTY
1	301042	WLDMT-SUPPORT VALVE	2
2	64244	U-BOLT: .375 X 5.13 X 8 X 5.13 (12R)	2
	301045	BAR-BOLTING (8R)	2
	1021757	BOLT-HEX: .38 X 5.00 NC GR5 ZP (8R)	4
3	1016999	NUT-TOPLOCK: .38 NC GR5 ZP	12
4	302354	PLATE-MOUNT VALVES ADC	1
5	1011600	BOLT-HEX: .38 X 1.00 NC GR5 ZP	8
6	302261	VALVE-ADC 3 BANK (2018 - CURRENT)	1
7	1011828	WASHER-FLAT .38 ZP	6
8	73426	VALVE-DUAL COUNTER BALANCE	1
	301854	CARTRIDGE-VALVE DUAL COUNTER BALANCE	2
9	1011285	BOLT-HEX: .31 X 2.00 NC	2
10	1030700	NUT-TOPLOCK: .31 NC GR5 ZP	2
11	302430	SHIELD-ADC VALVE	2
12	59488	BOLT-CRG: .38 X 1.00 NC GR5 ZP	4
13	1011576	NUT-HEX: .38 NC GR2 ZP	4

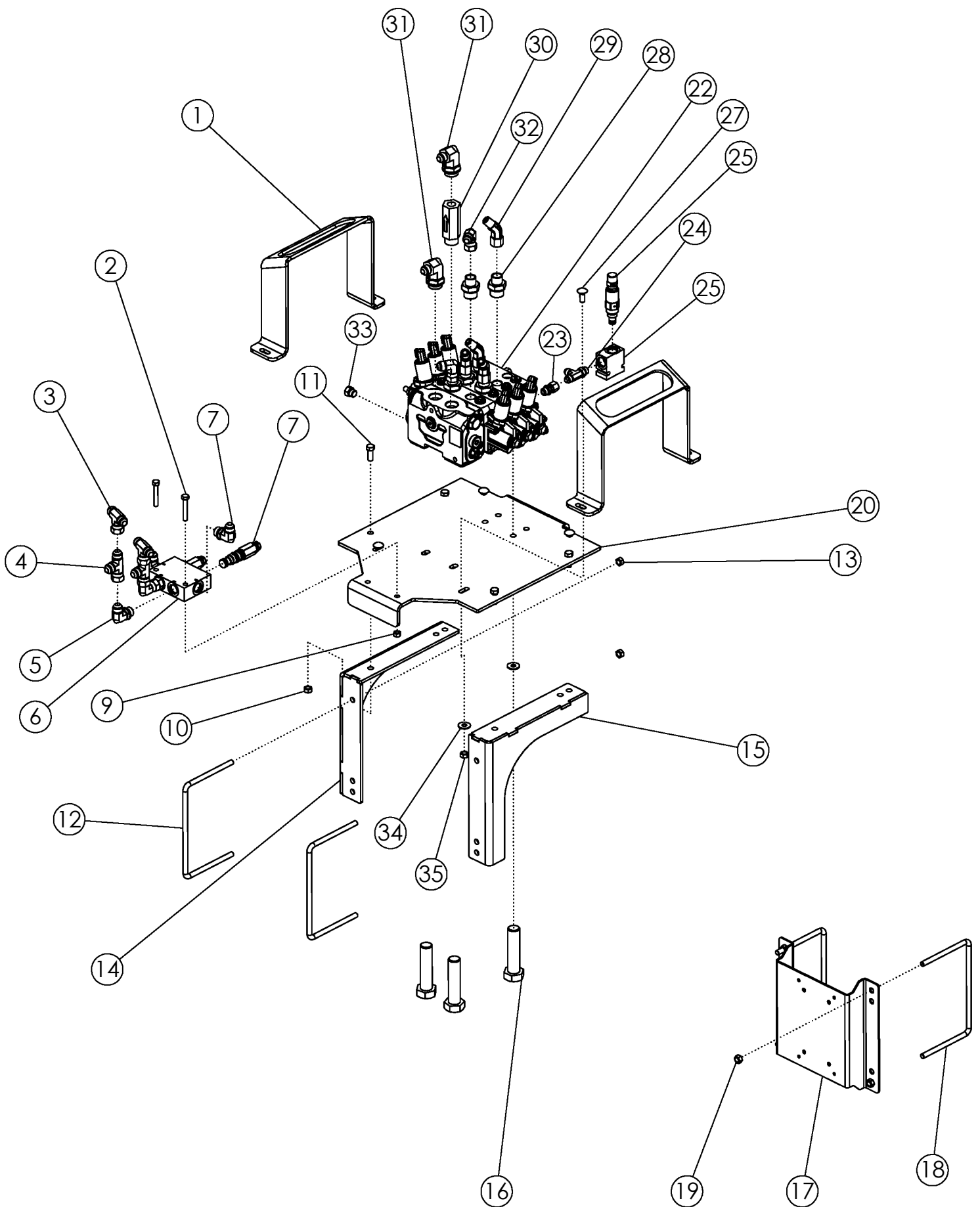

## ADC HYDRAULIC COMMON

ITEM	PART NO.	DESCRIPTION	QTY
1	302430	SHIELD-ADC VALVE	2
2	1011285	BOLT-HEX: .31 X 2.00 NC GR5 ZP	2
3	66603	FTG-TEE: 8MJ-8MJ-8FJX	2
4	63015	FTG-TEE: 8MJ-8FJX-8MJ	2
5	58560	FTG-ELBOW: 8MB-8MJ-90	2
6	73426	VALVE-DUAL COUNTER BALANCE	1
7	58560	FTG-ELBOW: 8MB-8MJ-90	2
9	1030700	NUT-TOPLOCK: .31 NC GR5 ZP	2
10	1016999	NUT-TOPLOCK: .38 NC GR5 ZP	4
11	1011600	BOLT-HEX: .38 X 1.00 NC GR5 ZP	4
12	64244	U-BOLT: .375 X 5.13 X 8.00 X 5.13 ZP	2
13	1016999	NUT-TOPLOCK: .38 NC GR5 ZP	4
14	301044	PLATE-SUPPORT TOP 8R/12R	1
15	301043	PLATE-SUPPORT SIDE 8R	1
17	301046	PLATE-MNT CONTROL BOX ADC 8R/12R	1
18	64244	U-BOLT: .375 X 5.13 X 8.00 X 5.13 ZP	2
19	1016999	NUT-TOPLOCK: .38 NC GR5 ZP	4
20	302354	PLATE-ADC VALVE MOUNT (2018)	1
22	302261	VALVE-ADC 3 BANK (2018)	1
23	67008	FTG-ADAPTER: 6MB-6FJX	1
24	301033	FTG-TEE: 6MJ-6MB-6MJ	1
25	301018	VALVE-CASE DRAIN RELIEF (ADC)	1
27	59488	BOLT-CRG: .38 X 1.00 NC GR5 ZP	4
28	58195	FTG-ADAPTER: 10MB-8MJ	6
29	57663	FTG-ELBOW: 8MJ-8FJX-45	4
30	302262	VALVE-CHECK: 12MB - 12FB 5000 PSI	1
31	73494	FTG-ELBOW: 12MB-8MJ-90	2
32	57668	FTG-ELBOW: 8MJ-8FJX-90	2
33	63033	FTG-PLUG: 6MB	1
34	1011828	WASHER-FLAT: .38 ZP	4
35	1016999	NUT-TOPLOCK: .38 NC GR5 ZP	4
36	73421	CYLINDER-HYD 4 X 10-3000-0° ADC	2

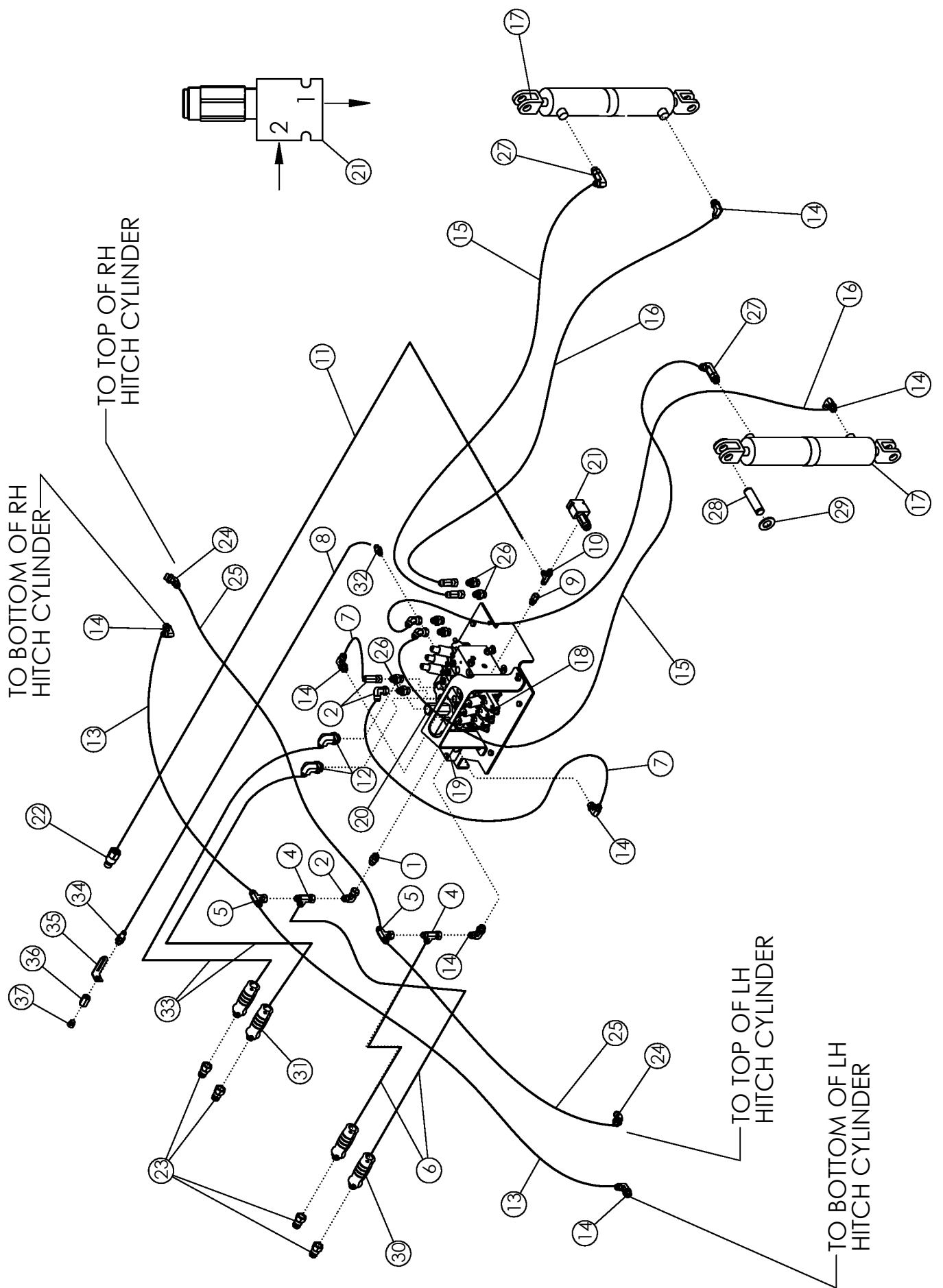



## ACTIVE DEPTH CONTROL HYDRAULICS

ITEM	PART NO.	DESCRIPTION	QTY
1	56226	FTG-ADAPTER: 8MB-8MJ	1
2	57668	FTG-ELBOW: 8MJ-8FJX-90	6
3	57663	FTG-ELBOW: 8MJ-8FJX-45	4
4	63015	FTG-TEE: 8MJ-8FJX-8MJ	2
5	66603	FTG-TEE: 8MJ-8MJ-8FJX	2
6	37705	HOSE: .50 X 128 8MB-8FJX	4
	301647	HOSE: .50 X 143 8MB-8FJX (XL)	
7	64263	HOSE: .50 X 011 8JFX-8FJX	2
8	303842	HOSE: .38 X 152 6FJX-6FJX	1
	303883	HOSE: .38 X 172 6FJX-6FJX (XL)	
9	67008	FTG-ADAPTER: 6MB-6FJX	1
10	301033	FTG-TEE: 6MJ-6MB-6MJ	1
11	301818	HOSE: .38 X 146 8MB-6FJX (8ROW)	1
	301648	HOSE: .38 X 160 8MB-6FJX (12ROW)	
	318827	HOSE: .38 X 180 8MB-6FJX (12ROW) (XL)	
12	73494	FTG-ELBOW: 12MB-8MJ-90	2
13	35770	HOSE: .50 X 52 8FJX-8FJX	2
14	58560	FTG-ELBOW: 8MB-8MJ-90	7
15	302786	HOSE: .38 X 236 8FJX-8FJX (12R)	2
	301819	HOSE: .38 X 212 8FJX-8FJX (8R)	
16	302787	HOSE: .38 X 248 8FJX-8FJX (12R)	2
	301820	HOSE: .38 X 226 8FJX-8FJX (8R)	
17	73421	CYLINDER-HYD 4 X 10 10-3000-0° ADC	2
	73629	SEAL KIT-CYL 4 X 10 (73421)	
18	302261	VALVE-ADC 3 BANK (2018)	1
19	73426	VALVE-DUAL COUNTER BALANCE	1
20	302262	VALVE-CHECK: 12MB - 12FB 5000 PSI	1
21	301018	VALVE-CASE DRAIN RELIEF	1
22	69119	FTG-CASE DRAIN 3/8 FLAT FACE	1
	36290	PIONEER TIP 8010-15P (#8 ORB)	
23	36290	PIONEER TIP 8010-15P (#8 ORB)	4
24	58515	FTG-ELBOW: 8MB-8MJ-45	2
25	1015221	HOSE: .50 X 040 8FJX-8FJX (12R)	2
	57676	HOSE: .50 X 31 8FJX-8FJX (8R)	
26	58195	FTG-ADAPTER: 10MB-8MJ	7
27	305402	FTG-ELBOW: 8MB-8MJ-90L	2
28	320136	PIN-1.000 X 3.375 HRD W/GROOVE ZP	4
29	1016663	WASHER-FLAT: SAE 1.00 ZP	6
30	301911	HYD LABEL: .50 BLACK/GRAY SET	1
31	301920	HYD LABEL: .50 ORANGE/GRAY SET	1
32	303854	VALVE-CHECK: 6MB-6MJ MB --> MJ	1
33	37705	HOSE: .50 X 128 8FJX-8MB	4
	300037	HOSE: .50 X 153 8MB-8FJX (XL)	
34	303836	FTG-BULKHEAD: 6MB-6MJ	1
35	303837	PLATE-LOAD SENSE COUPLER LABEL	1
36	303608	FTG-ADAPTER: 6FB-6FB	1
37	63033	FTG-PLUG: 6MB	1

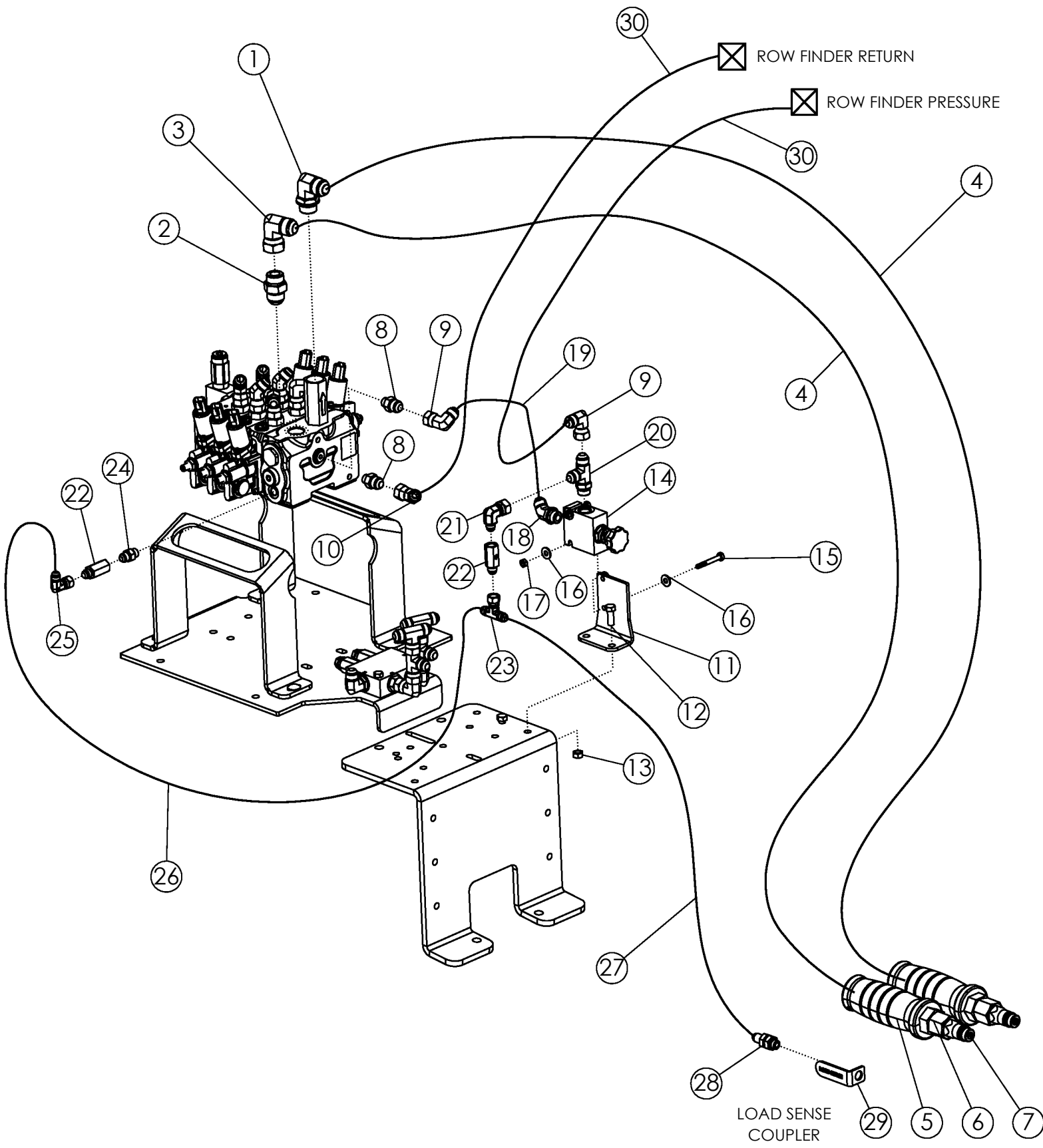



## KT-ADC ROW FINDER POWER BEYOND #303592 (OPTION)

ITEM	PART NO.	DESCRIPTION	QTY
1	64060	FTG-ELBOW: 12MB-12MJ-90	1
2	65918	FTG-ADAPTER: 12MB-12MJ	1
3	59041	FTG-ELBOW: 12MJ-12FJX-90	1
4	303602	HOSE: .75 X 128 12FJX-12MB	2
5	303600	HYD LABEL: .75 YELLOW/RED SET	1
6	311393	FTG-ADAPTER: 12FB-10MB	2
7	36291	PIONEER TIP 8010-16P (#10 ORB)	2
8	62024	FTG-ADAPTER: 6MB-8MJ	2
9	57668	FTG-ELBOW: 8MJ-8FJX-90	2
10	57663	FTG-ELBOW: 8MJ-8FJX-45	1
11	303603	PLATE-FLOW CONTROL VALVE MOUNT	1
12	1011600	BOLT-HEX: .38 X1.00 NC GR5 ZP	2
13	1016999	NUT-TOPLOCK: .38 NC GR5 ZP	2
14	303594	VALVE-FLOW CONTROL 0-9 GPM PRESSURE COM.	1
15	1016211	BOLT-HEX: .25 X 2.00 NC GR5	2
16	1020416	WASHER-FLAT: .25 ZP	4
17	1030946	NUT-TOPLOCK: .25 NC GR5 ZP	2
18	58515	FTG-ELBOW: 8MJ-8FJX-45	1
19	305675	HOSE: .50 X 017 8FJX-8FJX	1
20	63016	FTG-TEE: 8MB-8MJ-8MJ	1
21	303599	FTG-ELBOW: 6MJ-8FJX-90	1
22	303593	VALVE-CHECK: 6FJX-6MJ	2
23	303595	FTG-TEE: 6MJ-6MJ-6FJX	1
24	37259	FTG-ADAPTER: 6MB-6MJ	1
25	57897	FTG-ELBOW: 6MJ-6FJX-90	1
26	304026	HOSE: .38 X 025 6FJX-6FJX	1
27	304027	HOSE: .38 X 124 6FJX-6FJX	1
28	303836	FTG-BULKHEAD: 6MB-6MJ	1
29	303837	PLATE-LOAD SENSE COUPLER LABEL ZP	1
30	63903	HOSE: .50 X 068 8FJX-8FJX	2

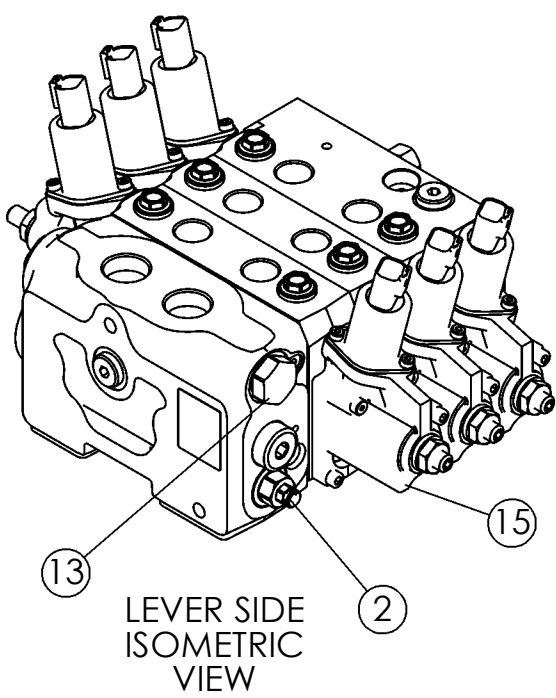
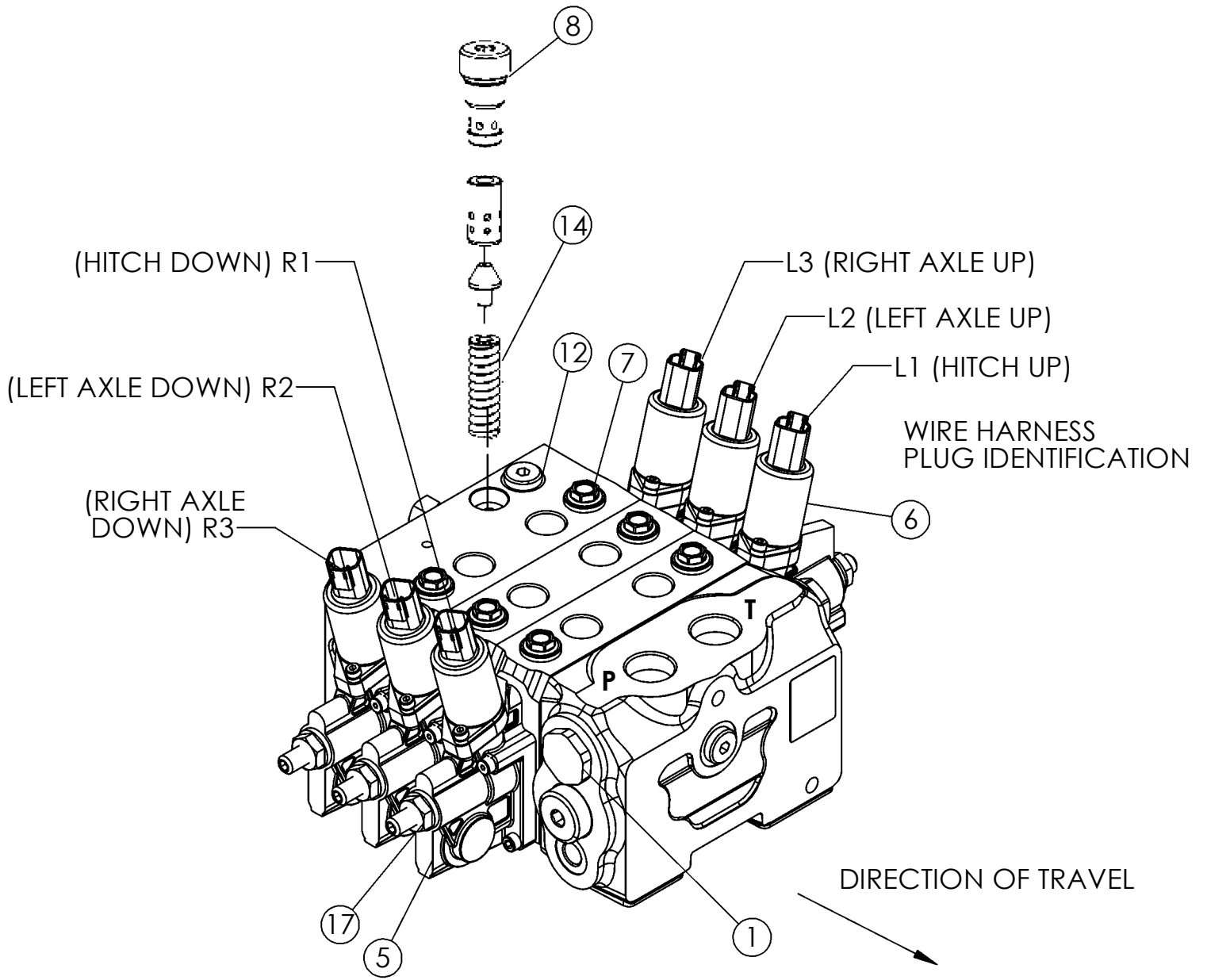

## VALVE-ADC 3 BANK #302261

ITEM	PART NO.	DESCRIPTION	QTY
1	303014	PLUG ASSY ADC 3-BANK VALVE	1
2	303015	LS RELIEF VALVE 255-350 BAR	
3	303016	H-SPOOL 65L	1
4	303017	D-SPOOL 15L	2
5	303018	EH ACTUATION WITH STROKE LIMITER-SPRING SIDE	6
6	303019	THOMAS MAGNETTE DEUTSCH CONNECTOR 12 V D	6
7	303020	PLUG ASSY	1
8	303021	PLUG S/A, PR. REDUCING VALVE (SPOOL END)	1
9	303022	KT-SEAL FOR BTWN INLET SECTION,(NOT SHOWN)	4
10	303023	KT-SEAL ELEC PROPRTNL END CAP (SPRING SIDE)	
11	303024	KT-SEAL ELEC PROPRTNL END CAP (LEVER SIDE)	
12	303025	SET SCREW FOR ADC VALVE	1
13	303026	LS DUMP VALVE PLUG ASSEMBLY	
14	303027	SPRING, PR. REDUCING VALVE	
15	303028	EH ACTUATION ASSEMBLY WITH STROKE LIMITER	
16	303029	COMP SECTION PLUG S/A	
17	303030	STROKE LIMITER SEAL NUT	

\*NOTE: VALVE COMES STANDARD WITH CLOSED CENTER PLUG

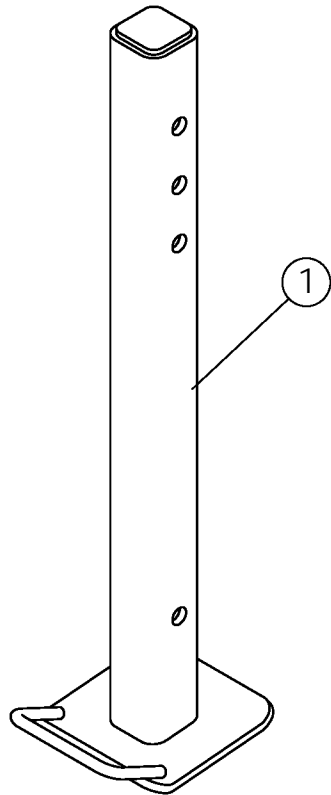
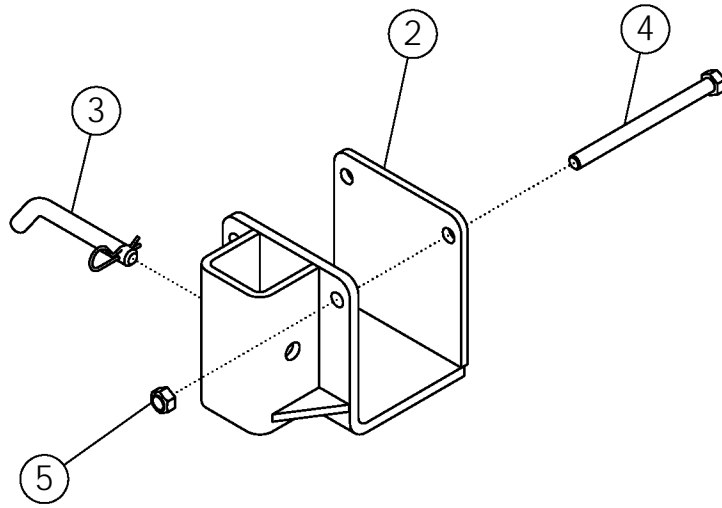

## HARVESTER STAND #63397 (OPTIONAL)

ITEM	PART NO.	DESCRIPTION	QTY
1	63382	WLDMT-STAND SUPPORT	1
2	63377	WLDMT-STAND MOUNT	1
3	63407	PIN-BENT	1
4	1018957	BOLT-HEX: .63 X 8.00 NC GR5 ZP	2
5	1016595	NUT-TOPLOCK: .63 NC GR5 ZP	2

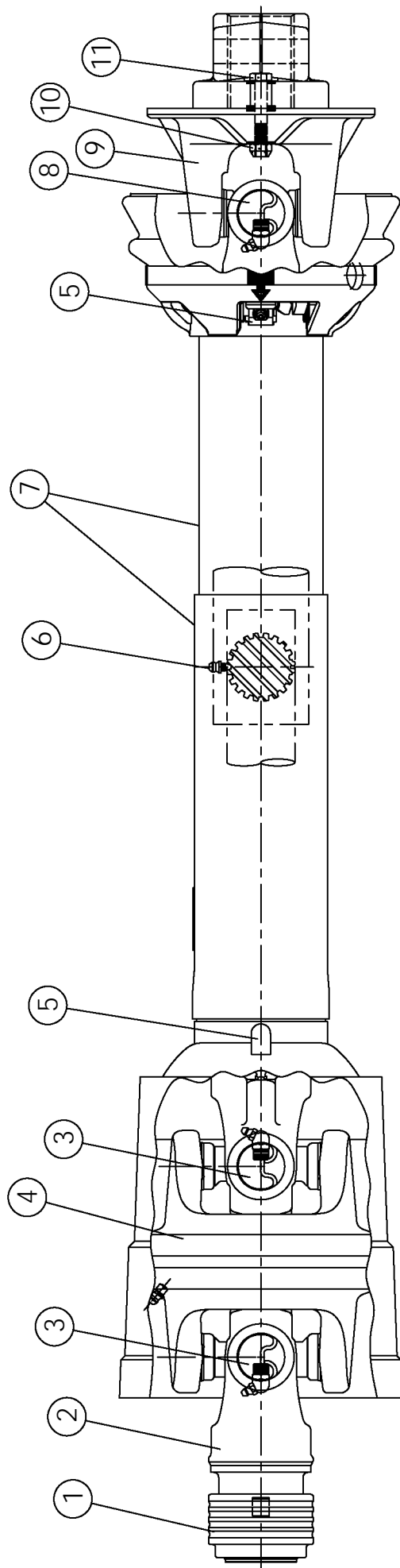

# PTO CV DRIVELINE #301558

## 1.75" - 20 SPLINE

ITEM	PART NO.	DESCRIPTION	QTY
1	62123	KT-SAFETY SLIDE LOCK REPAIR 1.750"	1
2	305902	YOKE ASSY-SAFETY SLIDE LOCK 1.750" CAT 6 CV	1
3	301841	KT-CROSS & BEARING CAT 6	2
4	305904	HOUSING-CV CENTER ASSY CAT 6	1
5	64398	KT-NYLON REPAIR UNIVERSAL	2
6	54161	ZERK-DRIVE LUBE FTG (PRESSED IN)	4
7	301559	GUARD SET-CV PTO HRV MAX 90" EXT.	1
8	54172	KT-CROSS & BEARING 35E SERIES	1
9	57286	ASSY-BALL SHEAR HRV	1
10	1030700	NUT-TOPLOCK: .31 NC GR5 ZP	1
11	1011285	BOLT-HEX: .31 X 2.00 NC GR5 ZP	1

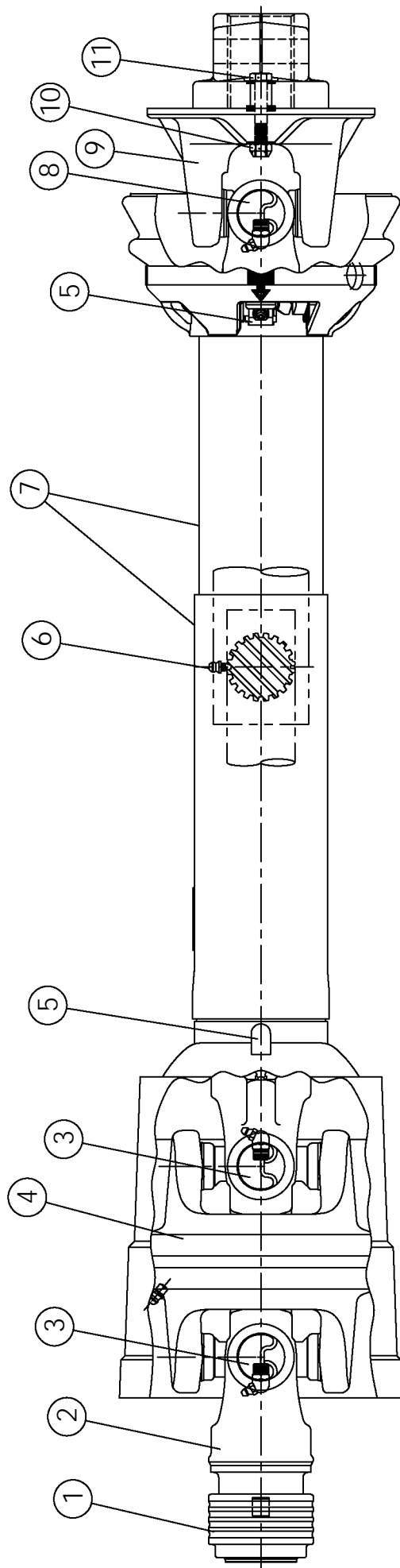



# PTO CV DRIVELINE #301575

## 1.375" - 21 SPLINE

ITEM	PART NO.	DESCRIPTION	QTY
1	62122	KT-SAFETY SLIDE LOCK REPAIR 1.375"	1
2	301824	YOKE ASSY-SAFETY SLIDE LOCK 1.375" CAT 6 CV	1
3	301841	KT-CROSS & BEARING CAT 6	2
4	305904	HOUSING-CV CENTER ASSY CAT 6	1
5	64398	KT-NYLON REPAIR UNIVERSAL	2
6	54161	ZERK-DRIVE LUBE FTG (PRESSED IN)	4
7	301559	GUARD SET-CV PTO HRV MAX 90" EXT.	1
8	54172	KT-CROSS & BEARING 35E SERIES	1
9	57286	ASSY-BALL SHEAR HRV	1
10	1030700	NUT-TOPLOCK: .31 NC GR5 ZP	1
11	1011285	BOLT-HEX: .31 X 2.00 NC GR5 ZP	1

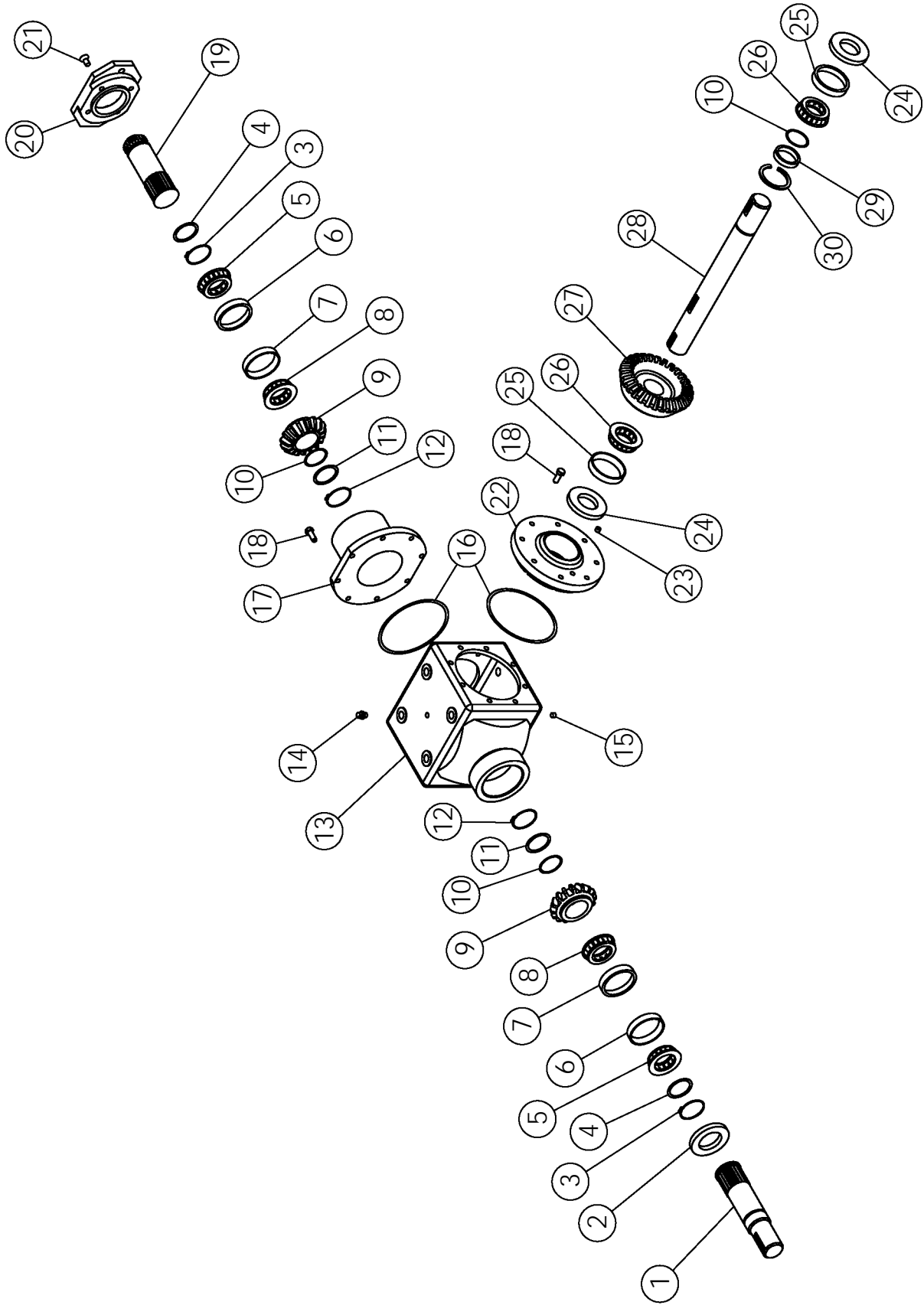

# GEARBOX (1.81:1) #62396 (PRIMARY: ONBOARD OPTION)

ITEM	PART NO.	DESCRIPTION	QTY
1	62721	QUILL SHAFT	1
2	62722	SEAL: 2.00 - 3.26	1
3	62724	SNAP RING	2
4	62723	WASHER 2.00 X .13	2
5	62725	BEARING CONE	2
6	62726	BEARING CUP	2
7	62727	BEARING CUP	2
8	62728	BEARING CONE	2
9	62729	PINION-16 TOOTH	2
10	62730	SHIM: 1.75 X .007	3
11	62731	WASHER 1.75 X .179	2
	68599	WASHER 1.75 X .135	
12	62732	SNAP RING	2
13	62733	CASE-900 SERIES	1
14	64408	VENT PLUG: .50 NPT (SQ. HD.)	1
15	62735	PLUG: .50 NPT	1
16	62736	SHIM-COVER	2
17	62737	QUILL HOUSING	1
18	62738	BOLT-HEX: .38 X 1.00 NC GR5 NP	16
19	62739	QUILL SHAFT	1
20	62740	FLANGE: 'SAE B' -2.00 BOLT	1
21	62741	SFHCS: .38 X .75 NC GR5	4
22	62742	COVER-OPEN .38 NPT	1
23	62743	PLUG: .38 NPT	1
24	62744	OIL SEAL: 1.75 X .31	2
25	62745	BEARING CUP	2
26	62746	BEARING CONE	2
27	64410	GEAR-29 TOOTH	1
28	64409	THRU SHAFT	1
29	302320	SPACER: 2.25 X .75	1
30	301491	RING-RETAINING: Ø2.25 X .125	1

### SHIMS USE AS NEEDED

64457	SHIM COVER
64461	SHIM: 1.375 ID X .007
62730	SHIM: 1.75 ID X .007
69225	SHIM: 2.75 OD X .007
62736	SHIM COVER
301622	SHIM: 3.00 OD X 2.25 ID
301492	SHIM

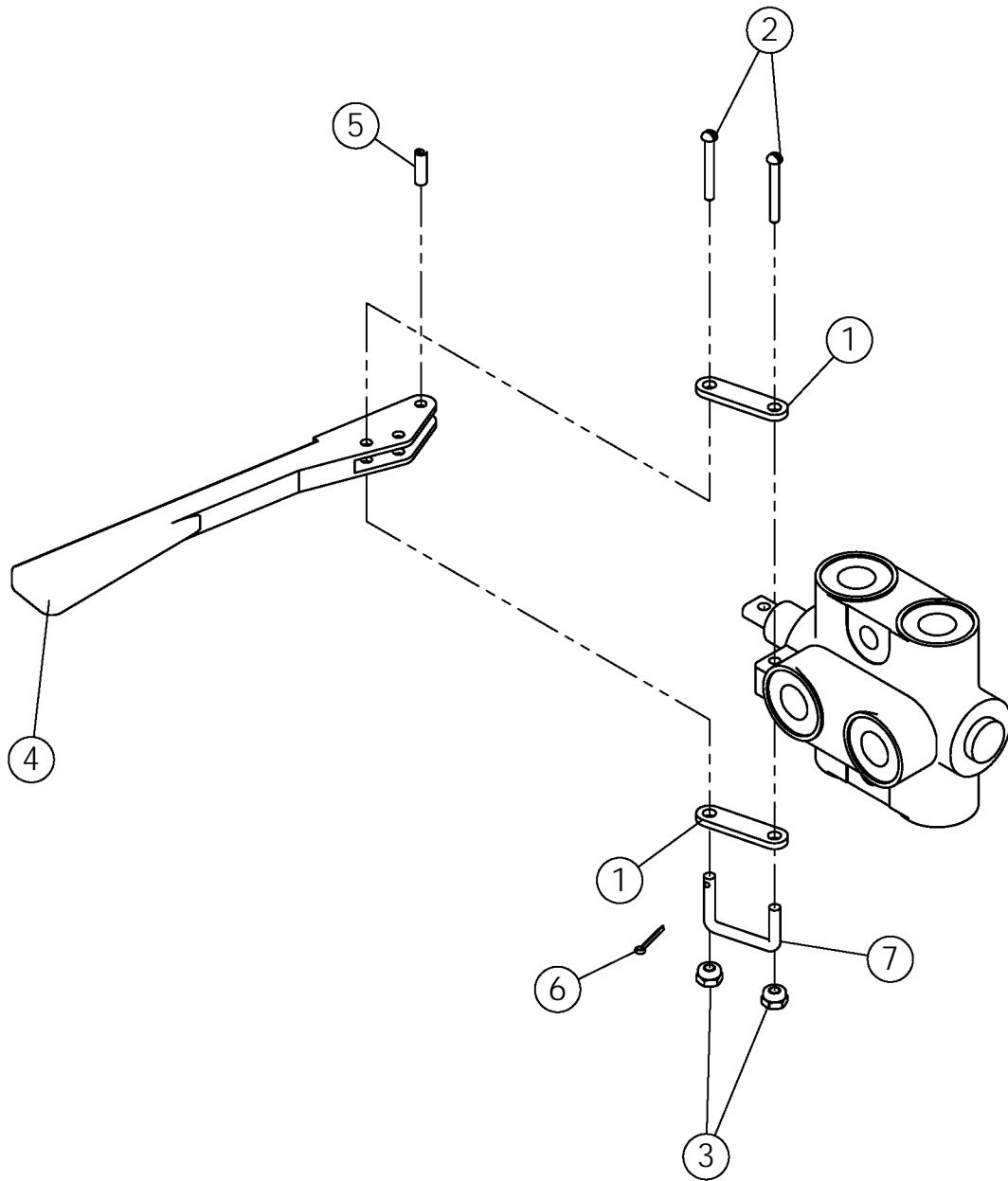

# SELECTOR VALVE #58470

ITEM	PART NO.	DESCRIPTION	QTY
	64432	QUAD RING SEAL KIT	2
	58470-1	HANDLE KIT	1
1	68060	PLATE-TAB SELECTOR VALVE ZP	2
2	1011303	SCREW-MACH RND SLT: #10-24 X 1.25	2
3	65712	NUT-NYLOCK: 10-24 GR2 SS	2
4		HANDLE	1
5		SPRING PIN	1
6		PIN-COTTER HANDLE	1
7		CLIP-HANDLE	1

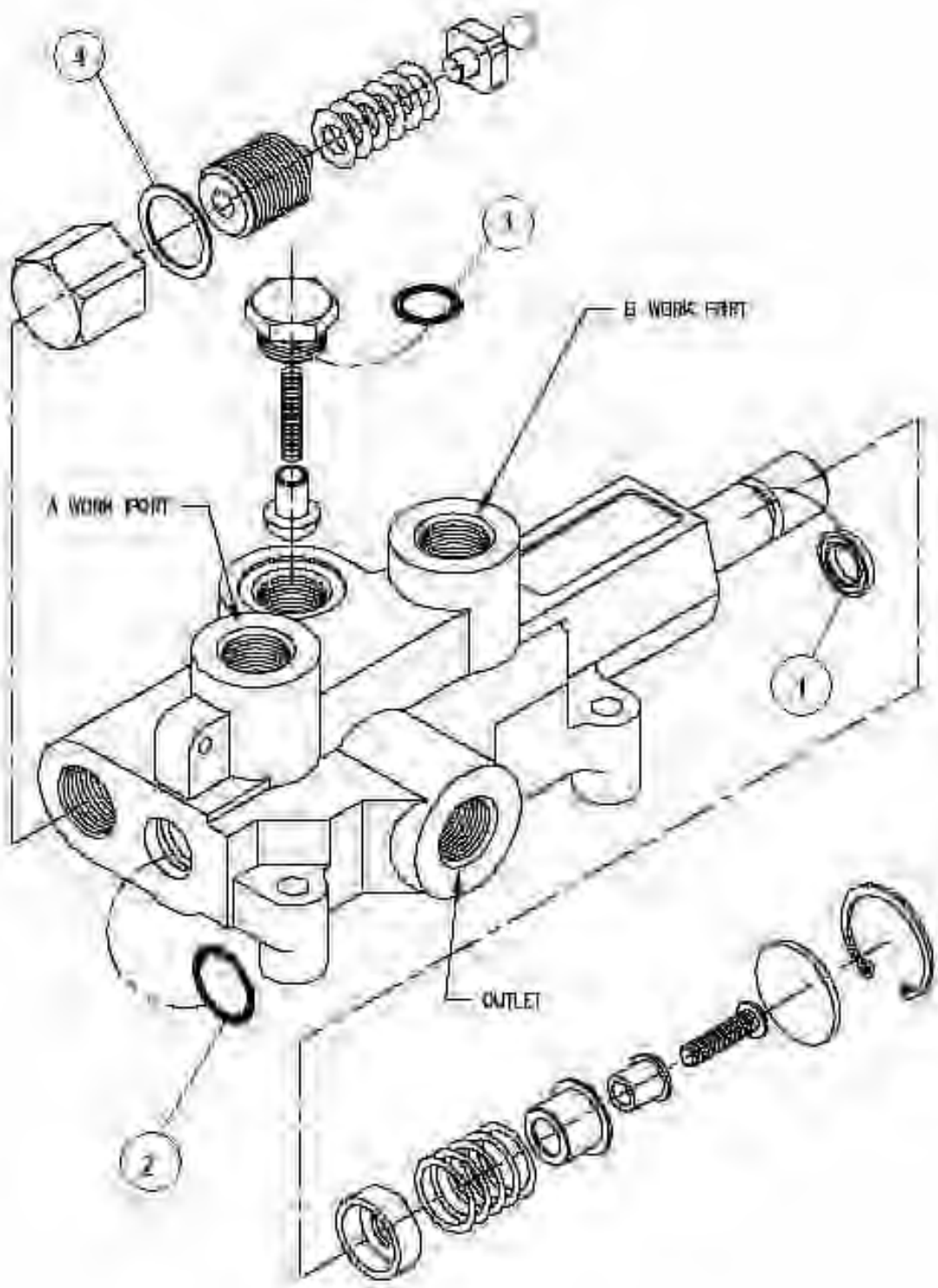

# ROW FINDER VALVE #301150

ITEM	PART NO.	DESCRIPTION	QTY
	62757	SEAL KIT	
1		U-CUP	1
2		O-RING	1
3		O-RING	1
4		ALUMINUM WASHER	1

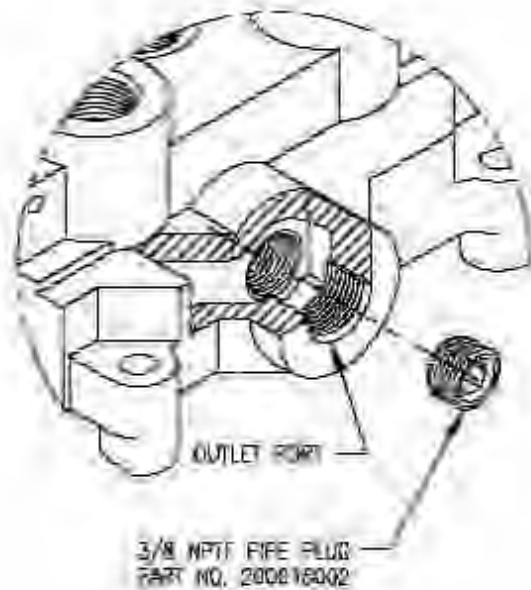

## OPEN CENTER TO CLOSED CENTER CONVERSION

THIS FEATURE ALLOWS AN OTHERWISE OPEN CENTER VALVE TO BE CONVERTED TO CLOSED CENTER OPERATION. AS SHOWN ABOVE, A 3/8 NPTF PIPE PLUG IS INSTALLED IN THE BOTTOM OF THE OUTLET PORT TO BLOCK OPEN CENTER PASSAGE. A PIPE THREAD SEALANT SHOULD BE USED. THIS FEATURE IS STANDARD ON ALL VALVES WITH 3/4 NPTF INLET AND OUTLET PORTS. THE PIPE PLUG IS INCLUDED WITH THESE MODELS. DISCARD THE PIPE PLUG IF THE VALVE IS USED ON AN OPEN CENTER APPLICATION.

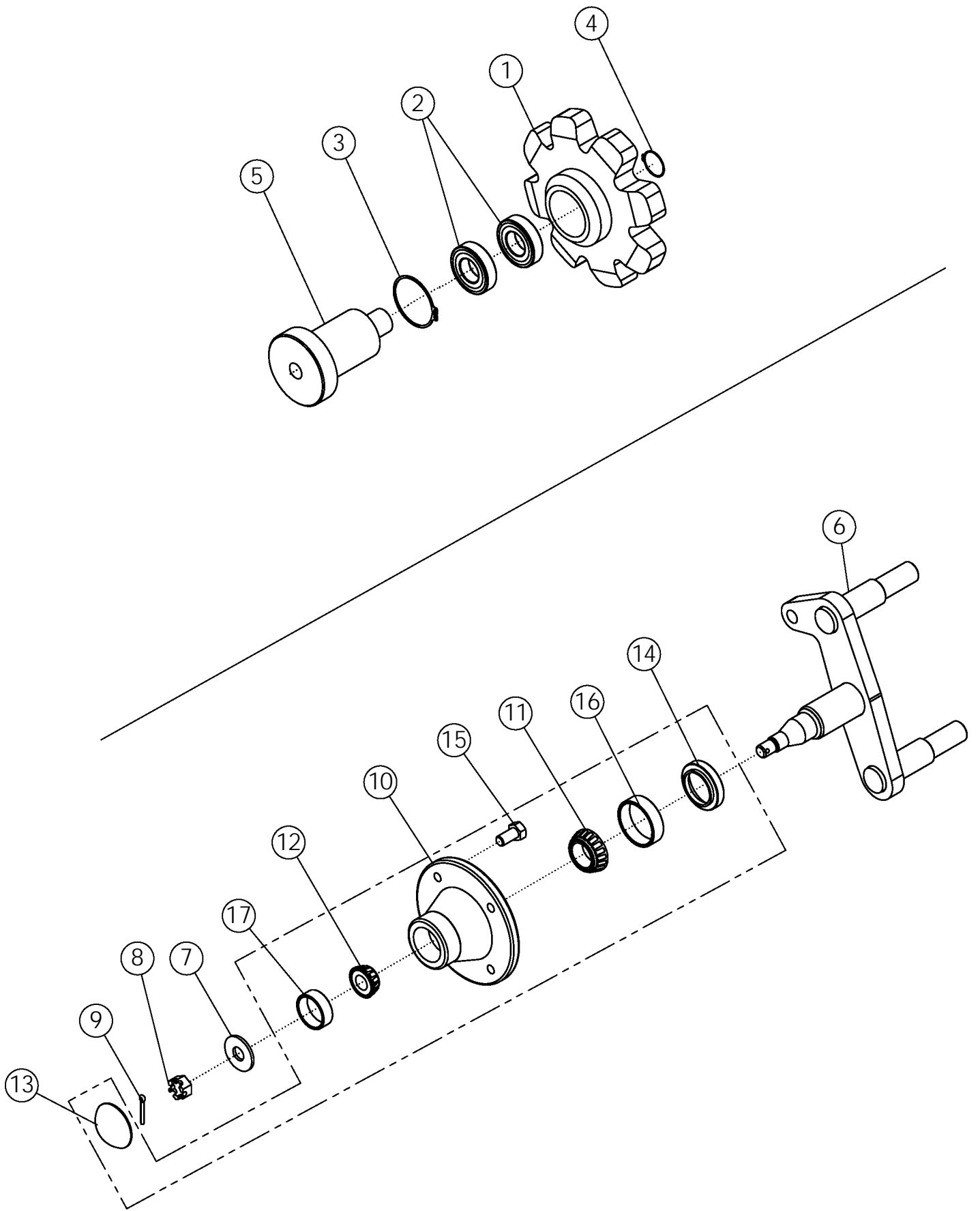



## SPROCKET #54824

ITEM	PART NO.	DESCRIPTION	QTY
1	56893	SPROCKET 56MM 8T	1
2	54108	BEARING 2"	2
3	54151	SNAP RING SR11	1
4	54154	SNAP RING SR3	1
5	56892	STUB SHAFT	1

## BELT TIGHTENER #56422

ITEM	PART NO.	DESCRIPTION	QTY
6	56421	WLDMT - SPINDLE	1
7	1013623	BUSHING-MACH: .63 NP	2
8	1013625	NUT-HEX: SLOT .63 NF GR5 ZP	1
9	1013626	PIN-COTTER: .16 X 1.25 ZP	1
10	1015157*	HUB-MACHINING	1
11	52245*	BEARING CONE-INNER	1
12	1013620*	CONE-BEARING	1
13	1013622*	HUB CAP	1
14	1029527*	SEAL	1
15	54646*	BOLT-LUG .50 X 1.00	4
16	1012360*	CUP-BEARING: LM 67010	1
17	1013268*	CUP-BEARING: LM 11910	1
18	56951	ASSY-HUB	1

\*Items are included in item 18

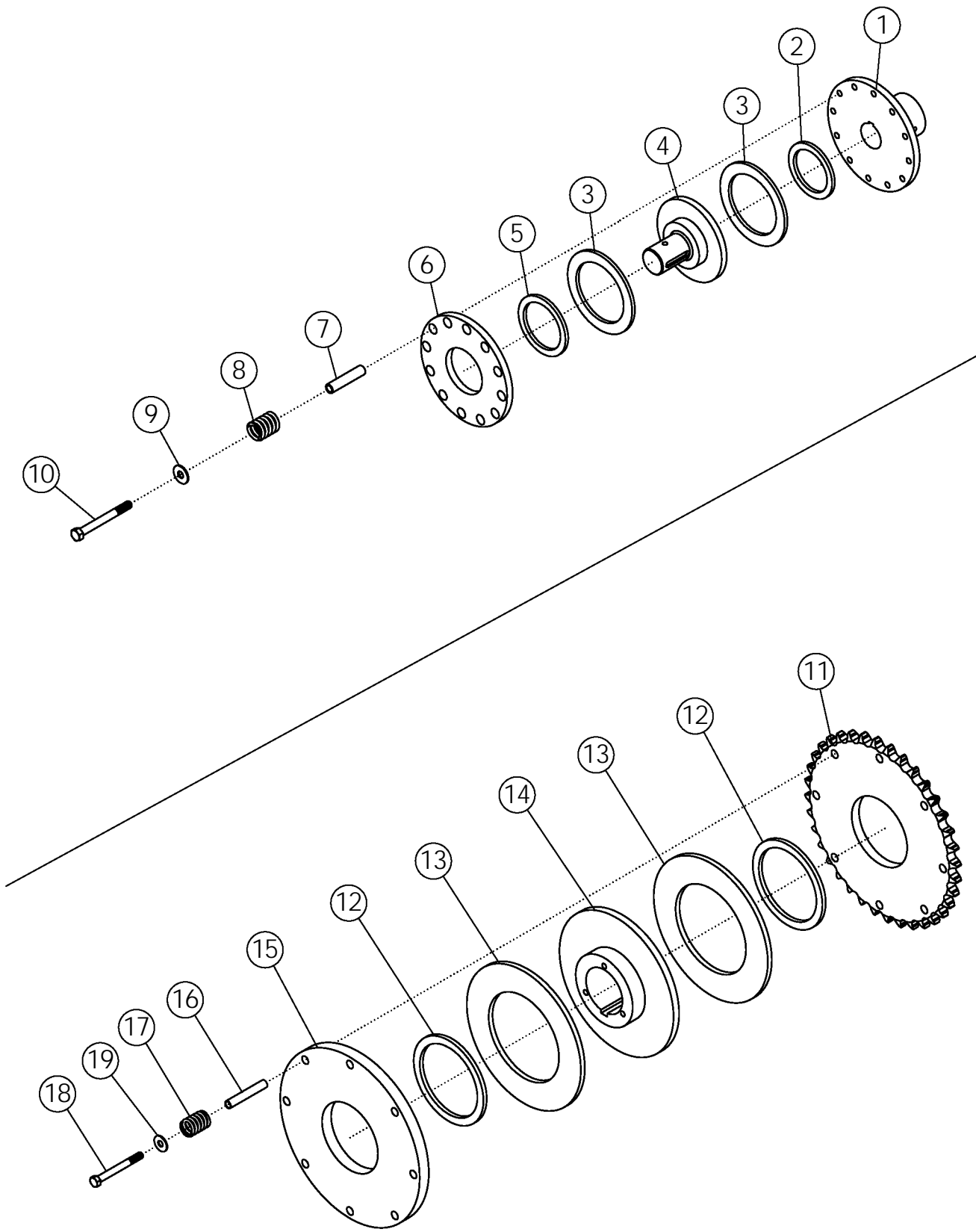

## SLIP CLUTCH (IN-LINE) #57926

ITEM	PART NO.	DESCRIPTION	QTY
1	58168	HUB-DRIVE	1
2	58169	BUSHING-BRONZE	1
3	58170	DISC-FIBER	2
4	58171	HUB-SLIP CLUTCH	1
5	58172	BUSHING-BRONZE	1
6	58173	PLATE-SLIP CLUTCH	1
7	301701	TUBE-SLIP CLUTCH (2.38)	6
8	58174	SPRING-SLIP CLUTCH	6
9	1011828	WASHER-FLAT: .38 ZP	6
10	58176	BOLT-HEX: .38 X 3.50 NC GR5 ZP	6

## SLIP CLUTCH/SPOCKET #57993

ITEM	PART NO.	DESCRIPTION	QTY
11	58177	SPROCKET	1
12	58207	BUSHING-BRONZE	2
13	58215	DISC-FIBER	2
14	58209	HUB-CLUTCH	1
15	58211	PLATE-SLIP CLUTCH	1
16	58213	TUBE-SLIP CLUTCH (2.870")	8
17	58174	SPRING-SLIP CLUTCH	8
18	58176	BOLT-HEX: .38 X 3.50 NC GR5 ZP	8
19	1011828	WASHER-FLAT: .38 ZP	8

## SLIP CLUTCH/SPOCKET #58335

ITEM	PART NO.	DESCRIPTION	QTY
11	58566	SPROCKET	1
12	58208	BUSHING-BRONZE	2
13	58216	DISC-FIBER	2
14	58210	HUB-CLUTCH	1
15	58212	PLATE-SLIP CLUTCH	1
16	301701	TUBE-SLIP CLUTCH (2.38)	6
17	58174	SPRING-SLIP CLUTCH	6
18	1013239	BOLT-HEX: .38 X 3.00 NC GR5 ZP	6
19	1011828	WASHER-FLAT: .38 ZP	6

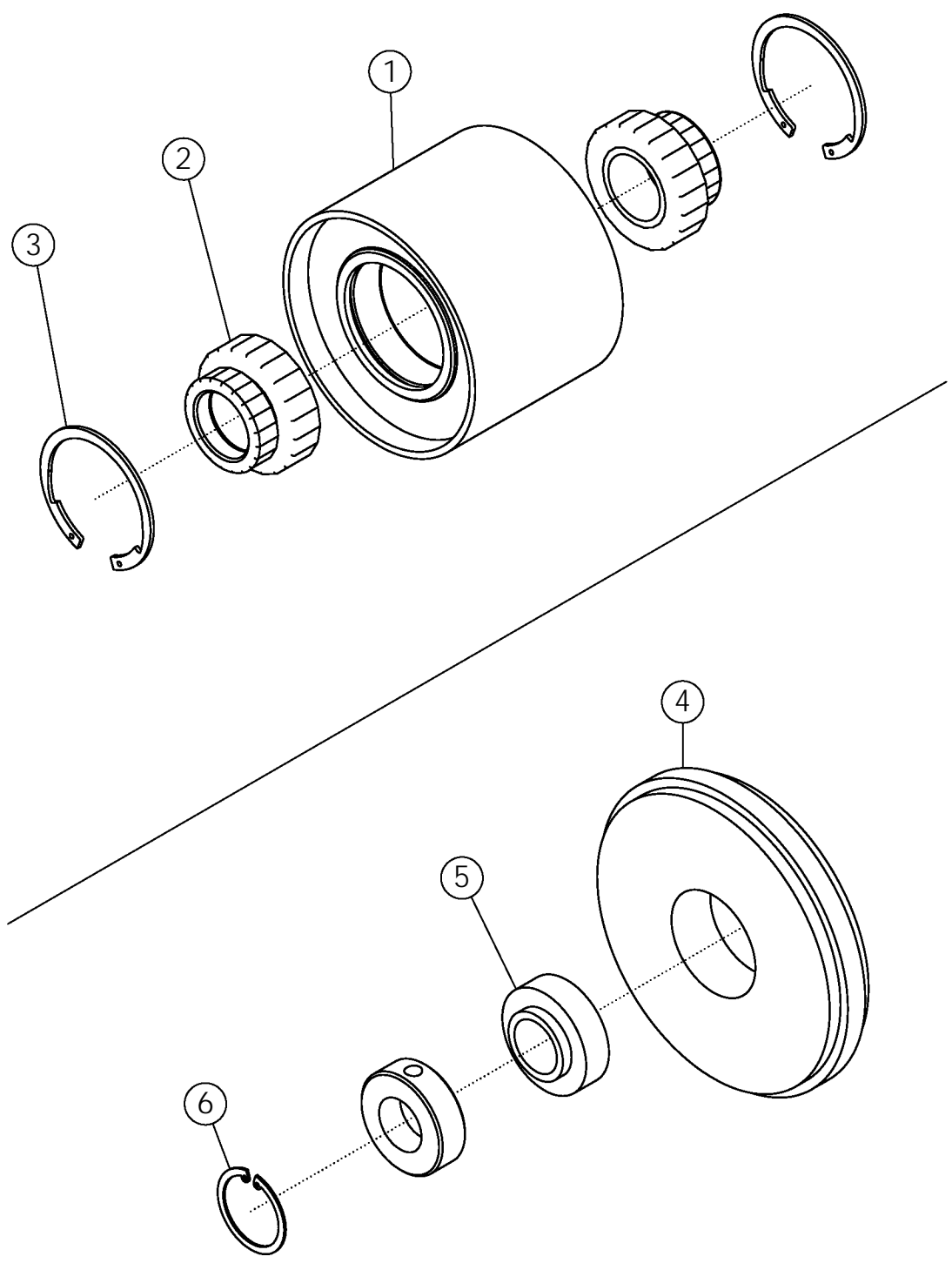

## IDLER PULLEY #56406

ITEM	PART NO.	DESCRIPTION	QTY
1	56405	WLDMT-PULLEY	1
2	56399	BALL BEARING 1.75	2
3	56400	RETAINING RING	2

## SPROCKET IDLER #56851

ITEM	PART NO.	DESCRIPTION	QTY
4	56851	IDLEMASTER 8.50 X 1.44	1
5	58806*	BEARING-IDLER	1
6	58805*	SNAP-RING	1

\* COMES WITH ITEM 4

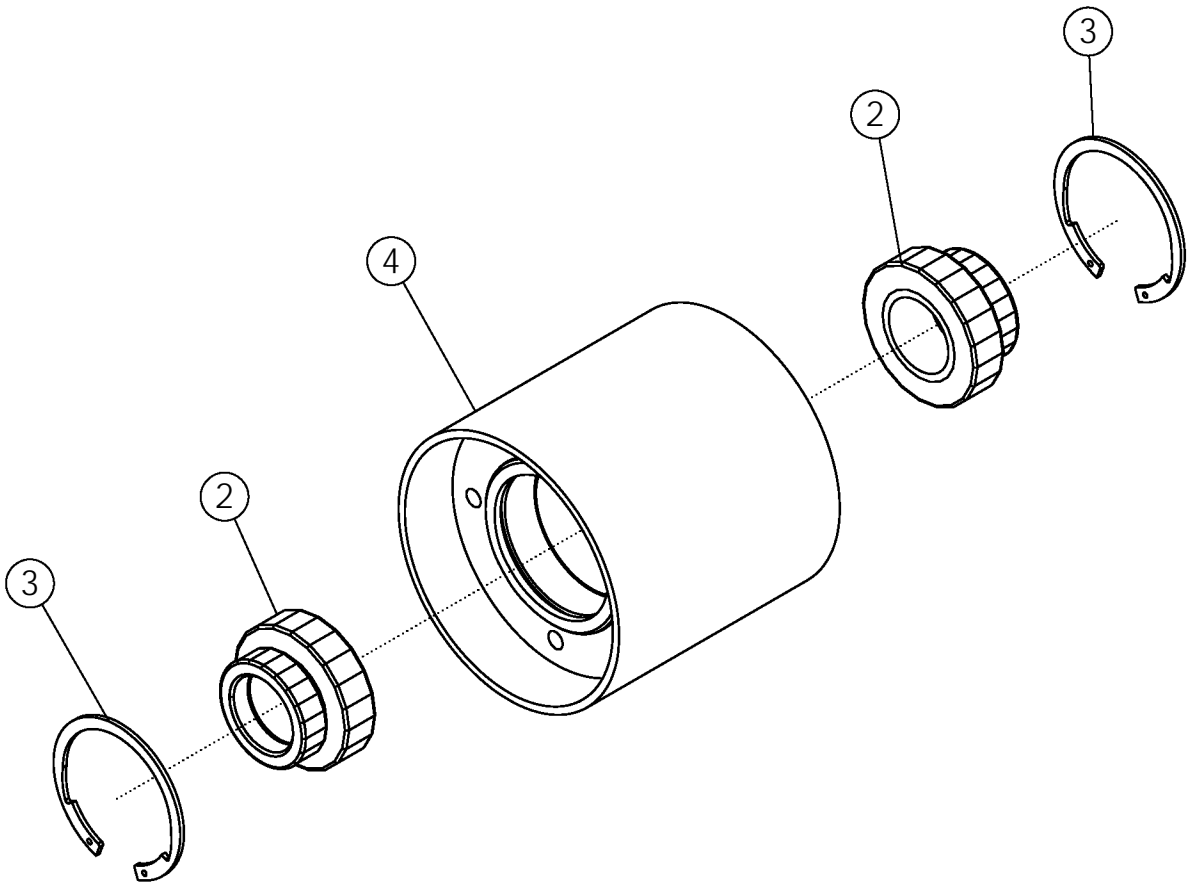

# REVERSE PULLEY #301822

ITEM	PART NO.	DESCRIPTION	QTY
1	301823	WLDMT-REVERSE PULLEY	1
2	56399	BALL-INSERT 1-3/4"	2
3	56400	RETAINING RING	2

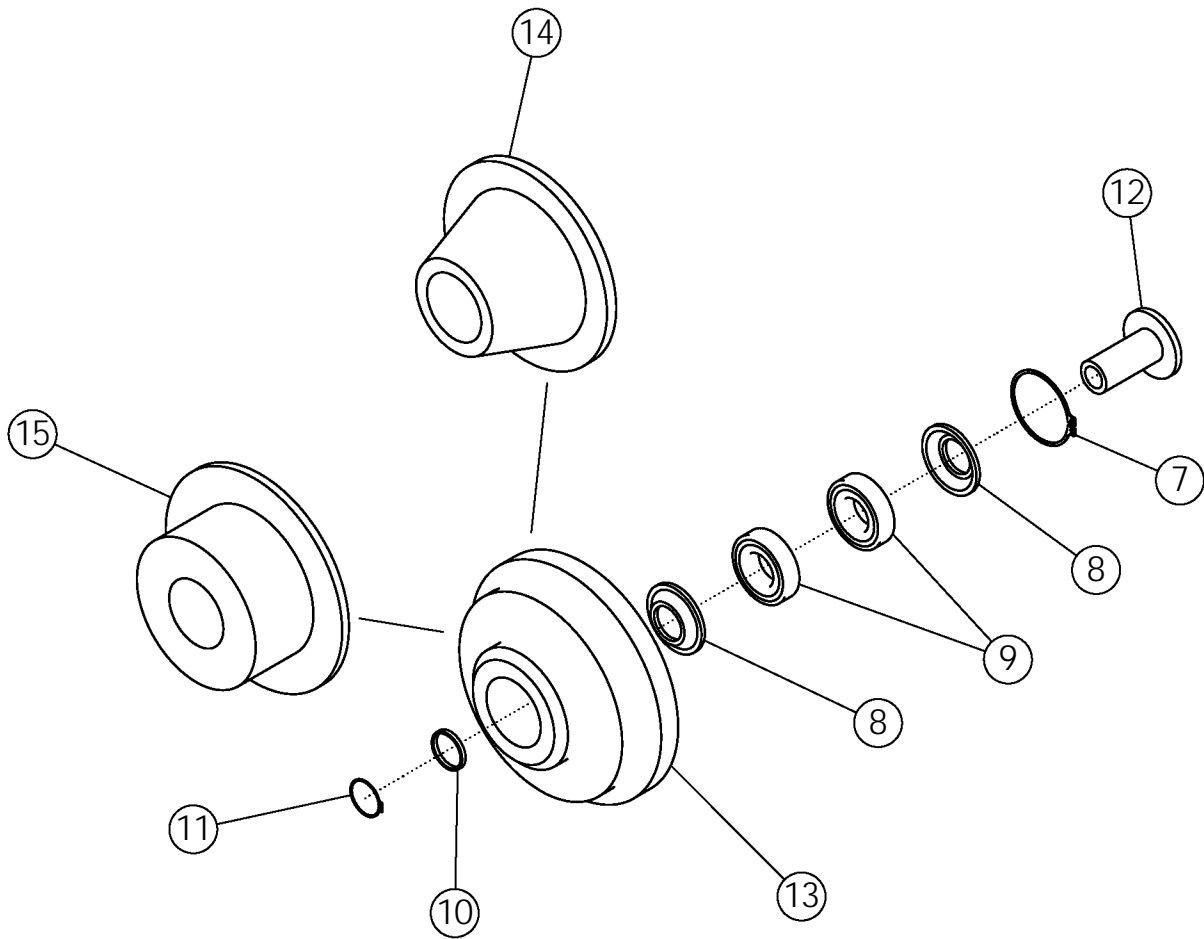
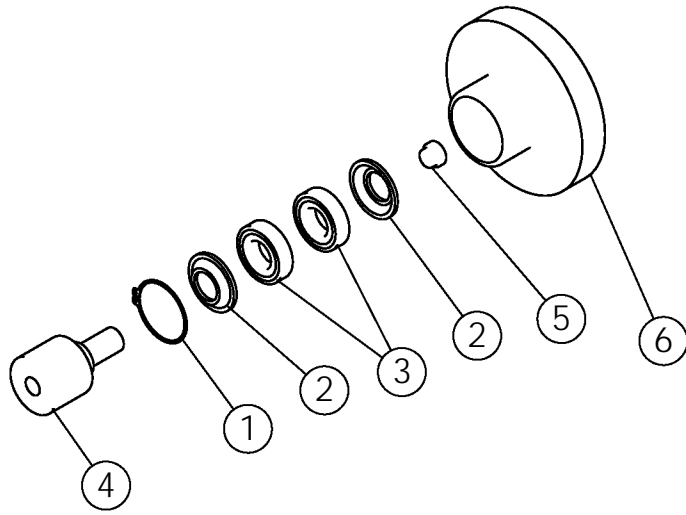



# ROLLERS

ITEM	PART NO.	DESCRIPTION	QTY
1	54151	SNAP RING SR11	1
2	54152	WASHER	2
3	54108	BEARING 2"	2
4	56885	STUB SHAFT LONG	1
5	62702	STUB SHAFT SHORT	1
6	54042**	ROLLER-STEP 6"	1
* *COMES WITH ITEMS 1-5			
7	54151	SNAP RING SR11	1
8	54152	WASHER	2
9	54108	BEARING 2"	2
10	54153	SPACER-NRS	1
11	54154	SNAP RING SR3	1
12	56889	STUB SHAFT	1
13	53951*	ROLLER-STEP FLANGE 7"	1
12	54155	STUB SHAFT	1
14	53950*	ROLLER-CONE 6"	1
12	54155	STUB SHAFT	1
15	59057*	ROLLER-RUBBER FLANGE 6.5"	1

\* COMES WITH ITEMS 7-12

# BELTED CHAIN LAP JOINT CONNECTION

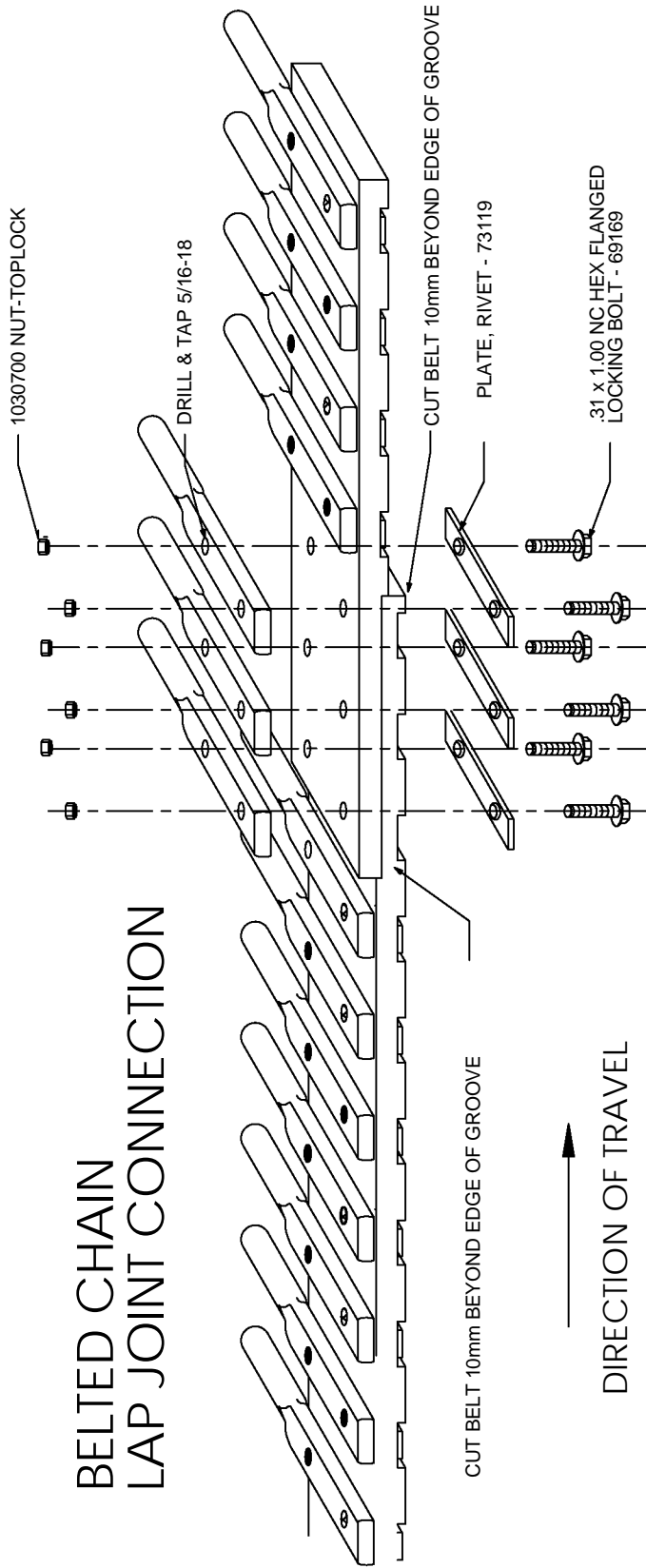

WARNING : ENSURE THAT SCREWS ARE SUFFICIENTLY TIGHT TO PRODUCE A BULGE AT THE EDGE OF THE BELT OF BETWEEN 1 AND 2mm (SEE DIAGRAM). FAILURE TO DO SO MAY CAUSE PREMATURE FAILURE AND VOID YOUR WARRANTY

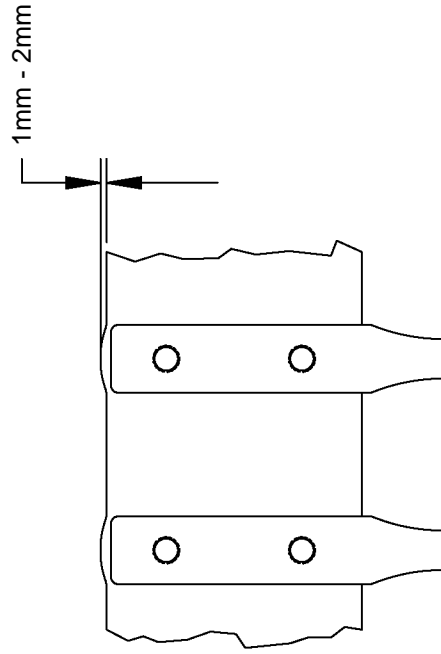

Elevator (Standard)				
Machine	Rod Diameter	ST	FLT	
6R/8R	0.5	73122	69336	
Elevator (Double)				
Machine	Rod Diameter	ST	FLT	
6R/8R	0.5	301528	301526	
Apron				
Machine	Rod Diameter	ST	UP	
6R22/8R22	0.5	73122	73123	
6R22/8R22	0.625	69660	69661	
6R30	0.625	64994	69953	

# REPAIR KIT - BELTED CHAIN #69541

## KIT CONSISTS OF:

- 1.25 FT - BELT, NO-PROFILE
- 8 EA - PLATE, RIVET
- 16 EA - SCREW
- 16 EA - NUT

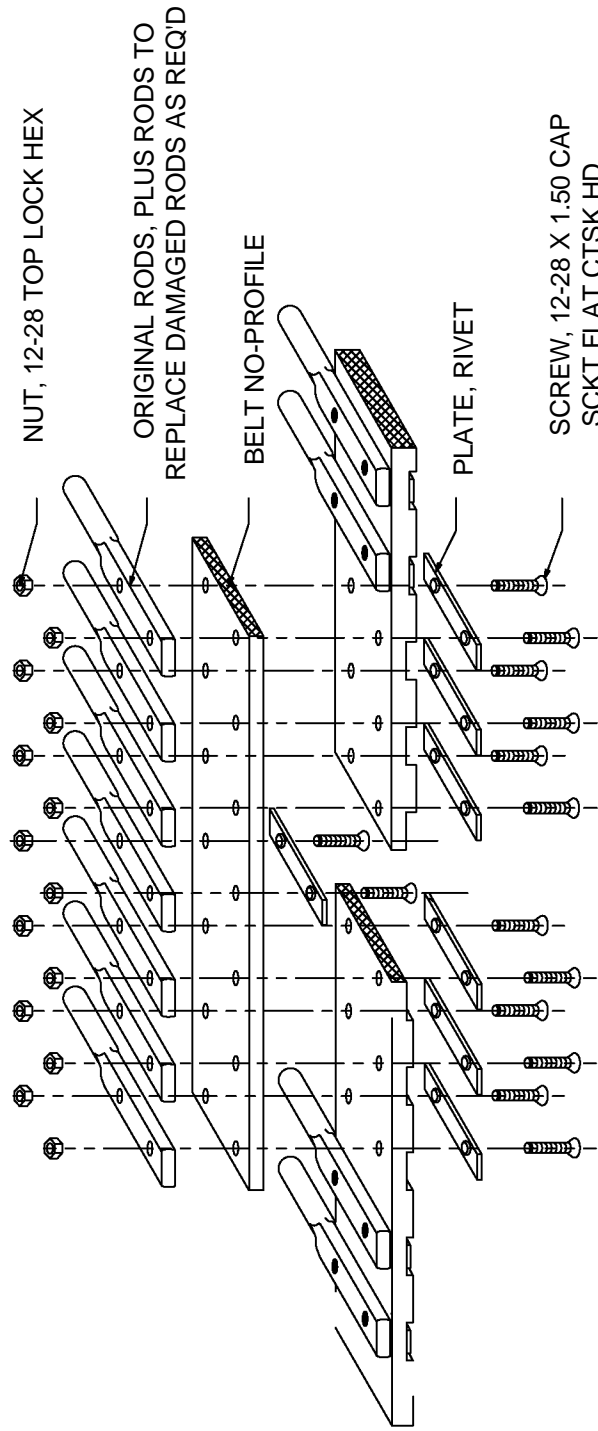

## REPAIR PROCEDURE

1. REMOVE RIVETS 3 PITCHES (MIN) EACH SIDE OF DAMAGED BELT.
2. TRIM OUT DAMAGED BELT.
3. CUT NO-PROFILE BELT TO GIVE MINIMUM OF 3 PITCHES OVERLAP BOTH SIDES OF DAMAGE.
4. LAY NO-PROFILE BELT ON BELT TO BE REPAIRED AND DRILL HOLES TO MATCH PITCH.
5. ASSEMBLE AS SHOWN.
6. TIGHTEN SCREWS TO FORM APPROXIMATELY 2mm BELT SWELL AT BOLTED JOINT.
7. CUT OFF SCREWS NEXT TO NUTS.
8. PEEN SCREWS TO SECURE NUTS.

# BELTED CHAIN RIVET CUTTER #62802

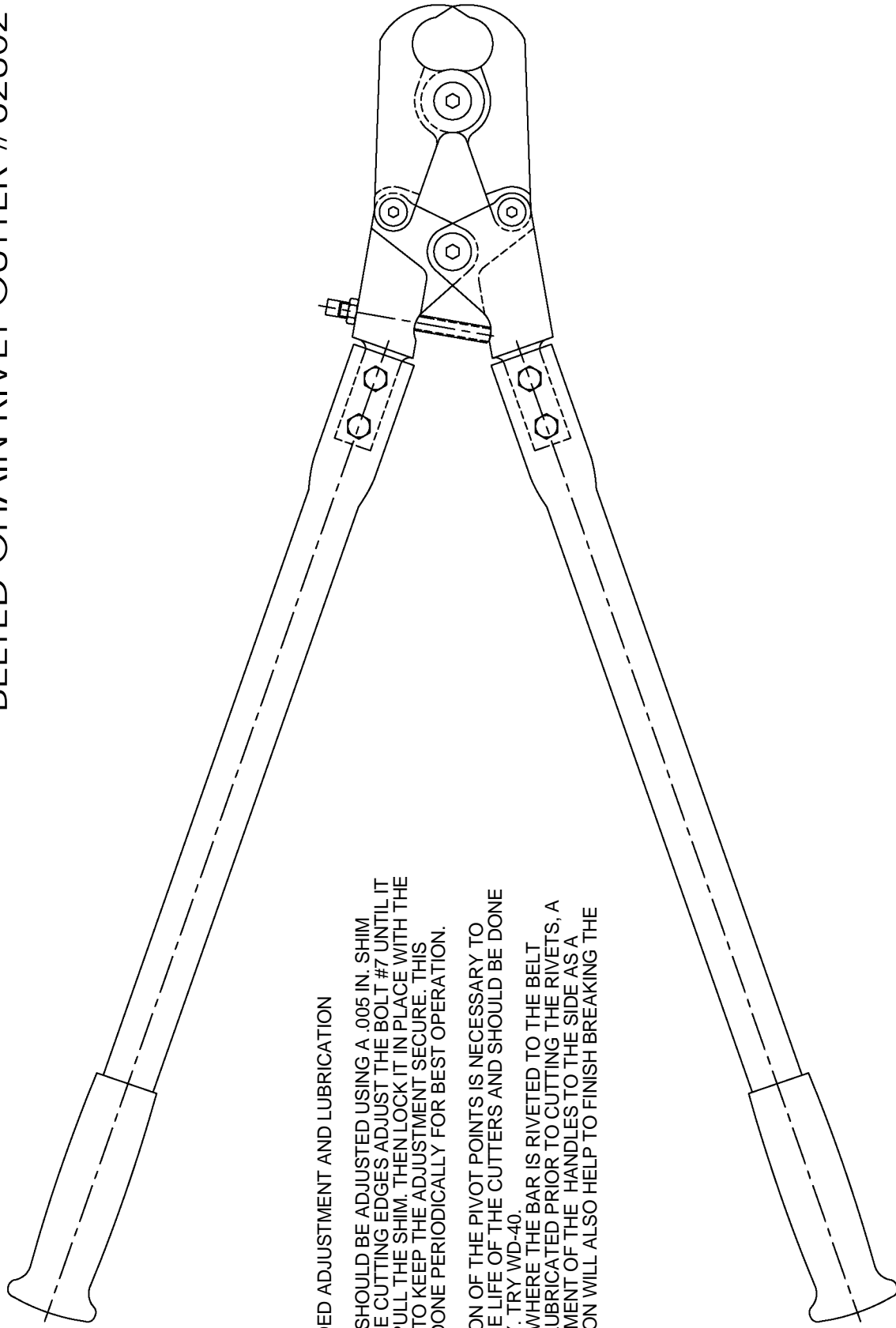

## RECOMMENDED ADJUSTMENT AND LUBRICATION

1. THE JAWS SHOULD BE ADJUSTED USING A .005 IN. SHIM BETWEEN THE CUTTING EDGES. ADJUST THE BOLT #7 UNTIL IT IS HARD TO PULL THE SHIM. THEN LOCK IT IN PLACE WITH THE LOCKNUT #8 TO KEEP THE ADJUSTMENT SECURE. THIS SHOULD BE DONE PERIODICALLY FOR BEST OPERATION.
2. LUBRICATION OF THE PIVOT POINTS IS NECESSARY TO PROLONG THE LIFE OF THE CUTTERS AND SHOULD BE DONE FREQUENTLY. TRY WD-40.
3. THE AREA WHERE THE BAR IS RIVETED TO THE BELT SHOULD BE LUBRICATED PRIOR TO CUTTING THE RIVETS. A LITTLE MOVEMENT OF THE HANDLES TO THE SIDE AS A PRYING ACTION WILL ALSO HELP TO FINISH BREAKING THE RIVET.

**THIS PAGE  
INTENTIONALLY  
LEFT BLANK**

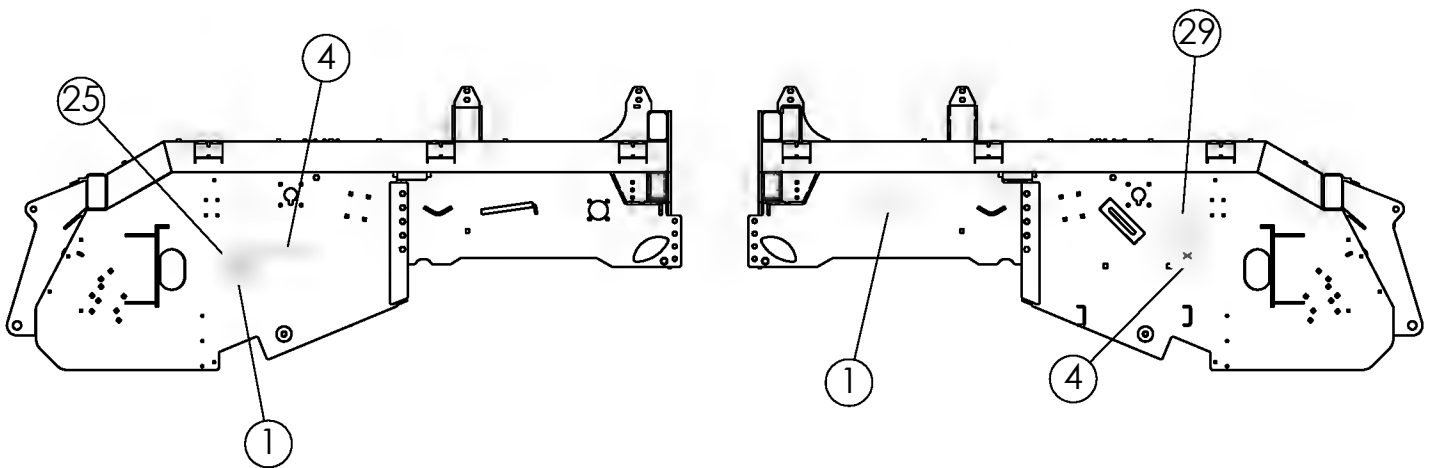
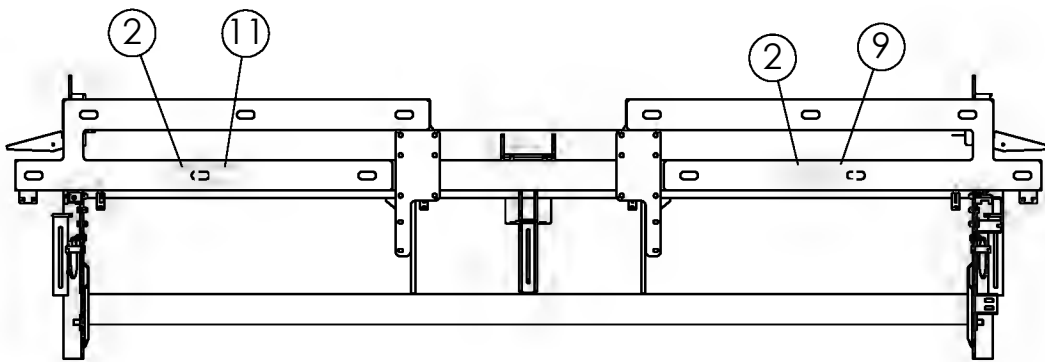
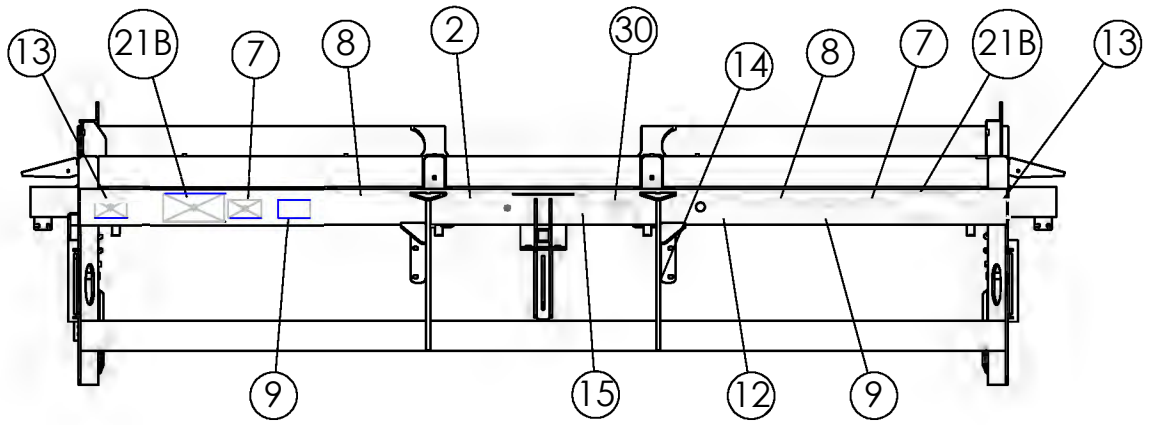

# DECALS

1 303272 QTY 2

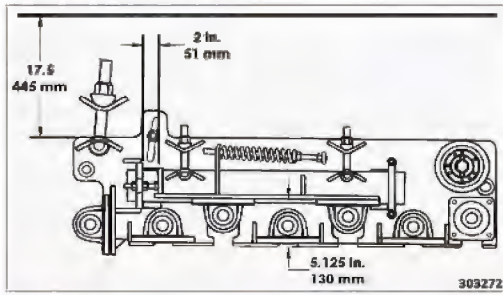

6 303513 QTY 1

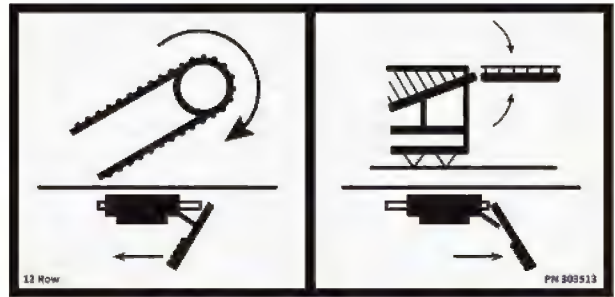

2 9971011 QTY 4



7 9971015 QTY 2



3 9971021 QTY 1



8 303263 QTY 2

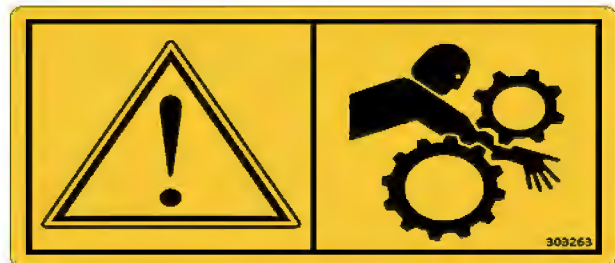

4 9971013 QTY 3

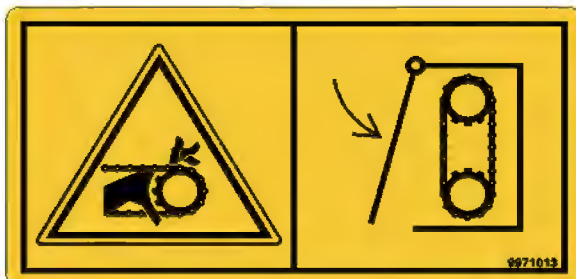

9 303268 QTY 5



5 9971025 QTY 1



CONTINUED

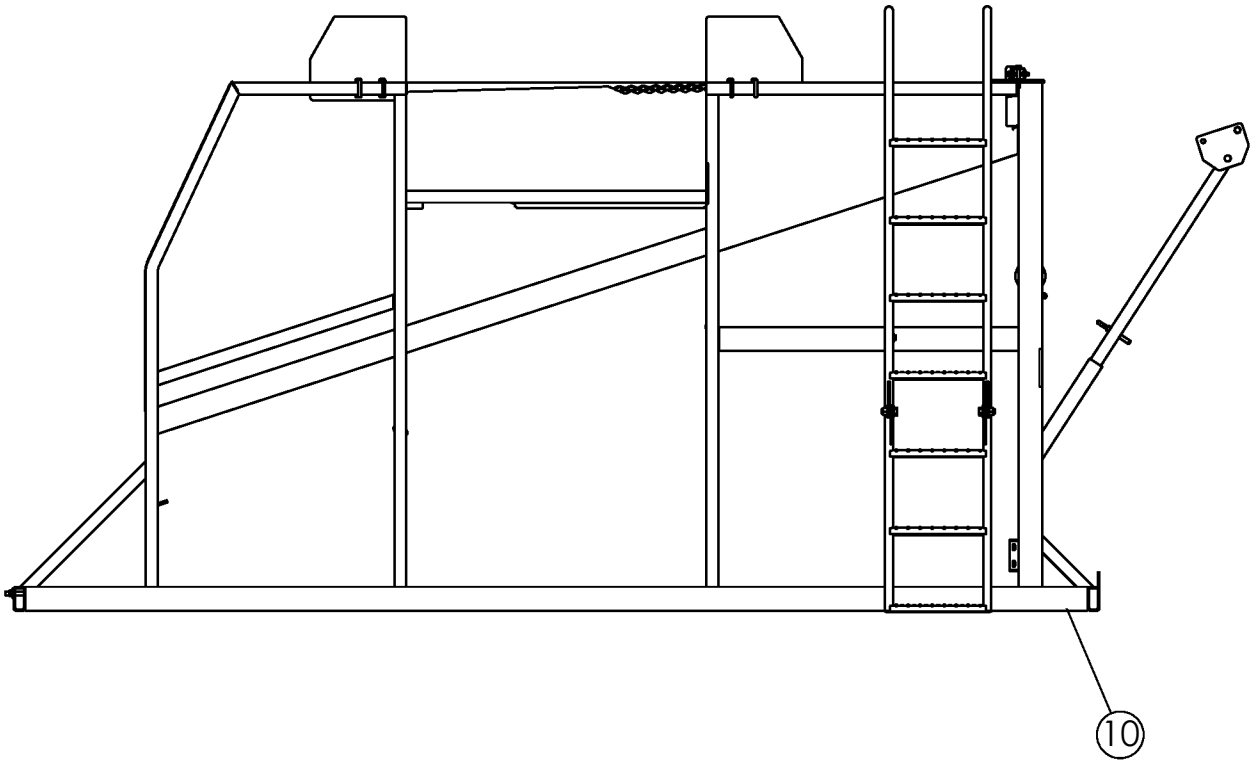
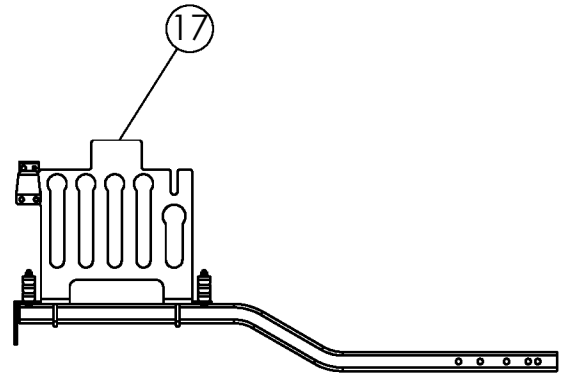
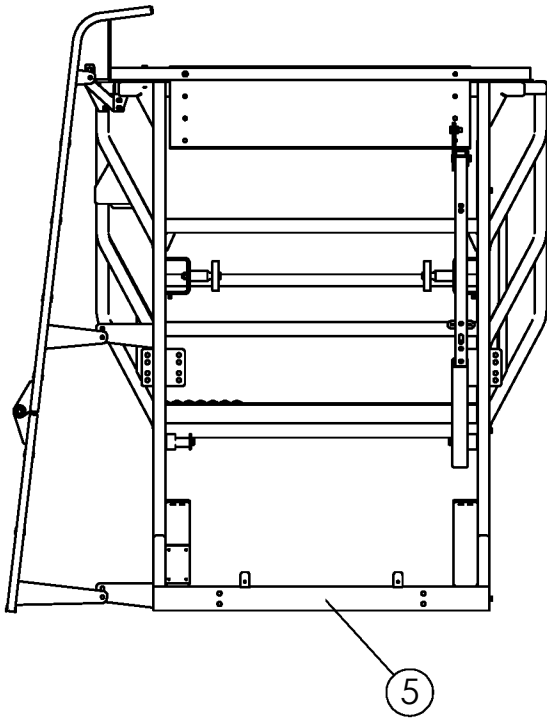



# DECALS (CONTINUED)

10 303277 QTY 1



15 997867 QTY 2

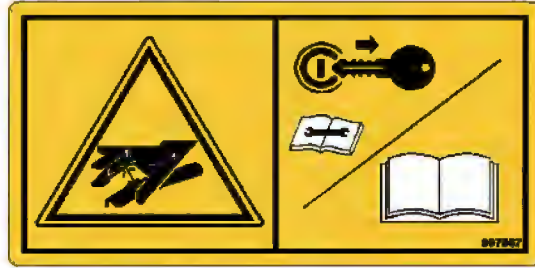

11 9971015 QTY 1



16 303269 QTY 2



12 997861 QTY 1



17 303849 QTY 1

Hose Color Chart - 2300/2500		
Black	Hitch	or Fasse Valve
Blue	Row Finder Constant	
Yellow	Row Finder Override	
Green	Elevator	
Orange	Active Depth Control * or Rear Lift	
Red	Rear Steering	
Blue/ Yellow	Left Rear Steer	or Left Rear Lift
Red/ Green	Right Rear Steer	or Right Rear Lift
Green/ Yellow	Wheel or Scrub Drive	
Yellow/ Red	ADC and Row Finder Constant *	
*Case Drain Line Must Be Used When Using the ADC Valve		
*Load Sense Line Must Be Used When Using Power Beyond		

13 303265 QTY 2



14 997859 QTY 1

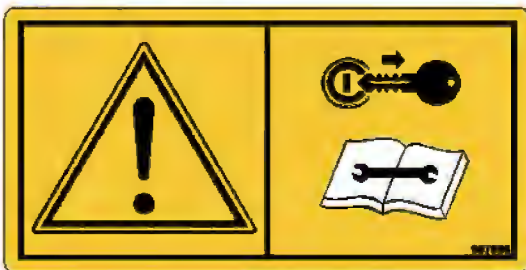

CONTINUED

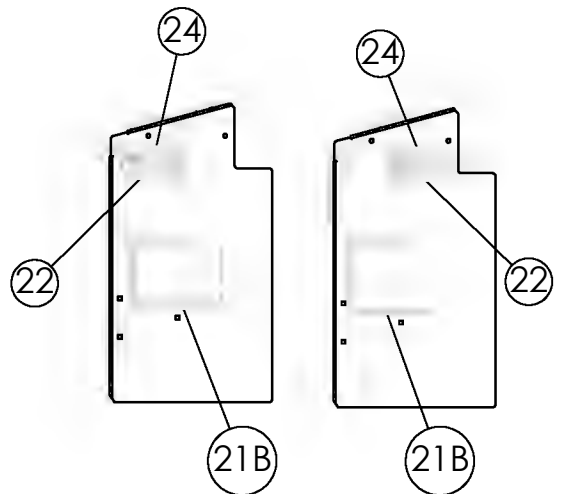
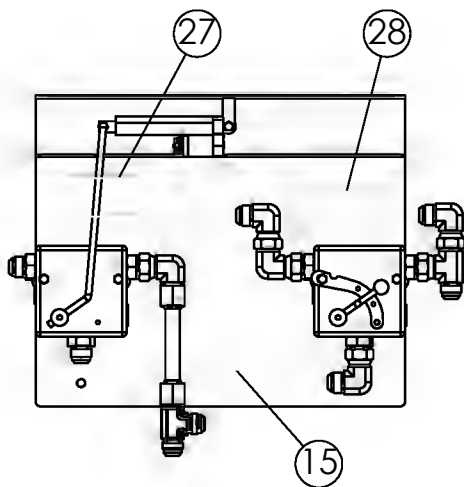
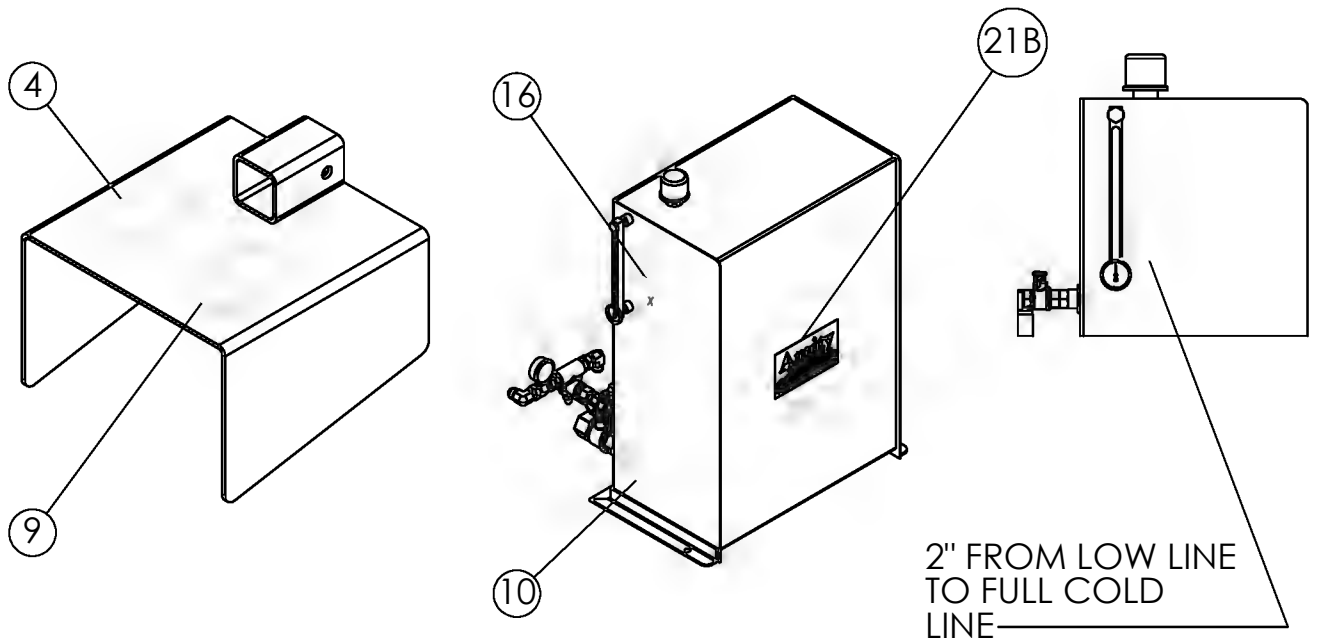
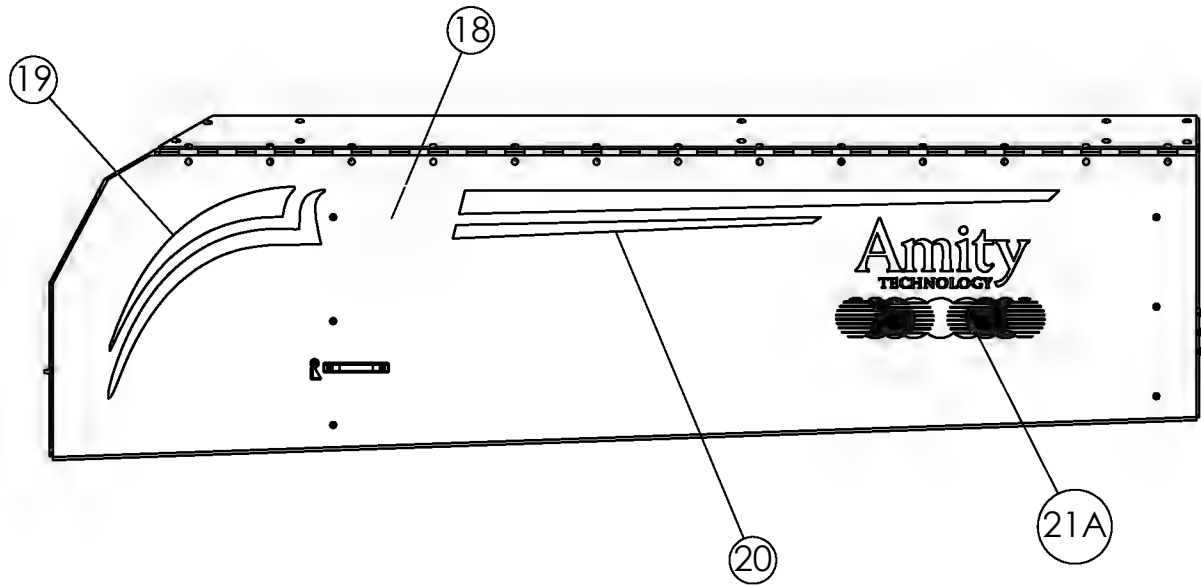

# DECALS (CONTINUED)

18 69292 2500 QTY 1  
 69291 2400  
 69290 2300

21A 69399 QTY 2 LARGE LOGO  
 21B 63465 QTY 5 SMALL LOGO

2400

Amity  
 TECHNOLOGY



19 69294 LH QTY 1  
 69297 RH QTY 1 NOT SHOWN

22 65330 QTY 2

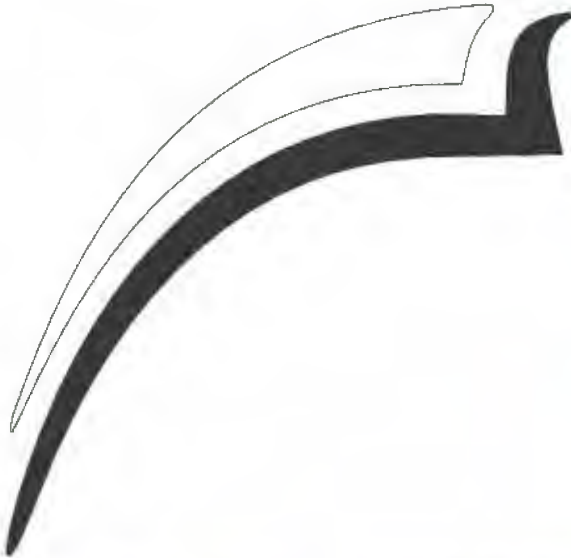

23 65331 QTY 4



24 65332 QTY 2



20 69295 LH QTY 1 69298 RH NOT SHOWN QTY 1



25 62873 QTY 1

26 303264 QTY 1

## Cleaning Bed Speed and Spring Adjustment

Spring Compression Adjustment	
B	13.50 In 34 cm
C	8.50 In 22 cm

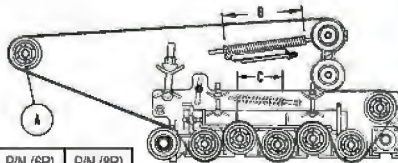

Sheave A	Outside Diameter	Grabroll RPM	P/N (6R)	P/N (8R)
6.8"	7.15 In 182 mm	506	56647	57681
6.2	6.55 In 166 mm	552	56646	57680
5.6"	5.95 In 151 mm	500	53668	57679

\* Available from your authorized WIC dealer

62873

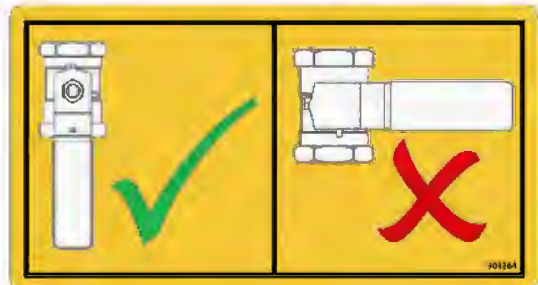

303264

# DECALS (CONTINUED)

27 303850 QTY 1

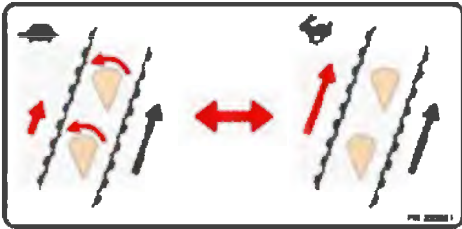

28 303851 QTY 1

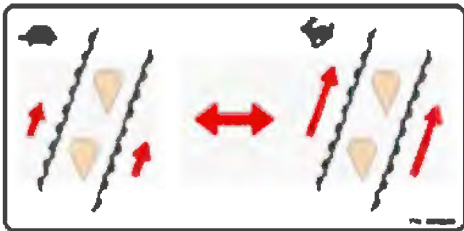

29 303804 QTY 1

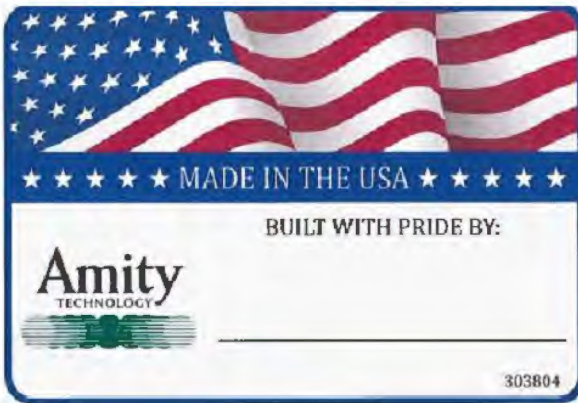

30 303769 QTY 1



INTENTIONALLY LEFT BLANK

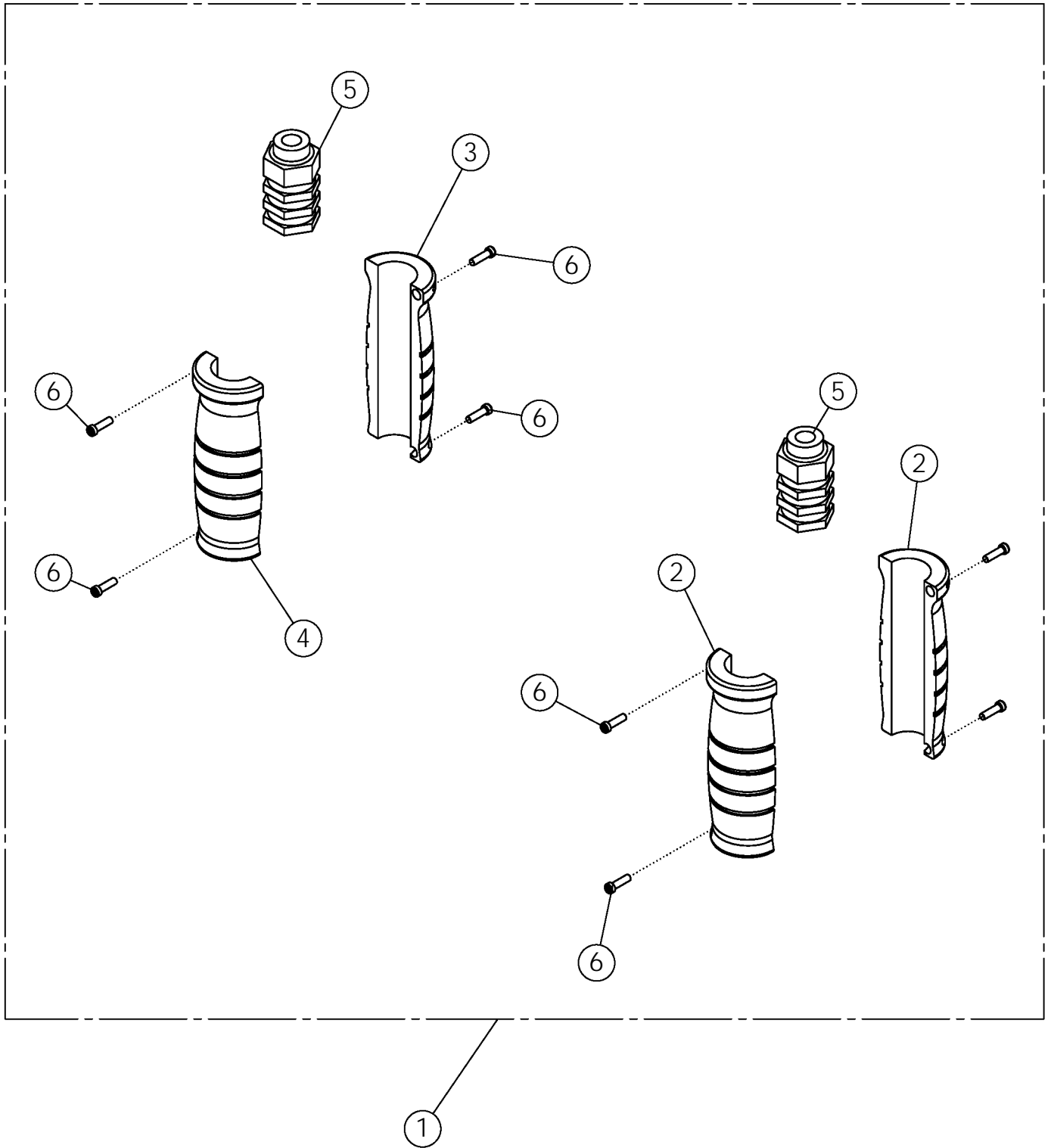

# HYDRAULIC LABEL ASSY

ITEM	PART NO.	DESCRIPTION	QTY
1	301920*	HYD LABEL: .50 ORANGE/GRAY SET	1
	301902*	HYD LABEL: .50 BLUE/GRAY SET	
	301917*	HYD LABEL: .50 YELLOW/GRAY SET	
	301914*	HYD LABEL: .50 GREEN/GRAY SET	
	301911*	HYD LABEL: .50 BLACK/GRAY SET	
	301908*	HYD LABEL: .50 RED/GRAY SET	
	302230*	HYD LABEL: .50 RED/GREEN SET	
	302226*	HYD LABEL: .50 BLACK/ORANGE SET	
	302227*	HYD LABEL: .50 BLUE/YELLOW SET	
	301923*	HYD LABEL: .75 GREEN/GRAY SET	
	301928*	HYD LABEL: .75 YELLOW/GRAY SET	
2		HYD LABEL: .50 HALF EXTEND	2
		HYD LABEL: .75 HALF EXTEND	
3		HYD LABEL: .50 HALF RETRACT	1
		HYD LABEL: .75 HALF RETRACT	
4		HYD LABEL: .50 GRAY HALF RETRACT	1
		HYD LABEL: .75 GRAY HALF RETRACT	
5		HYD LABEL: .50 CORE M & F O-RING	2
		HYD LABEL: .75 CORE M & F O-RING	
6		HYD LABEL: SET SCREW	8

\* COMES WITH ITEMS 2 THRU 6