

PARTS MANUAL

2024

3700 DEFOLIATOR

12 ROW 24

12 ROW 22

8 ROW 30

Amity
TECHNOLOGY



2800 7th Avenue North
Fargo, ND 58102

Phone: (701) 232-4199

Fax: (701) 234-1716

www.amitytech.com

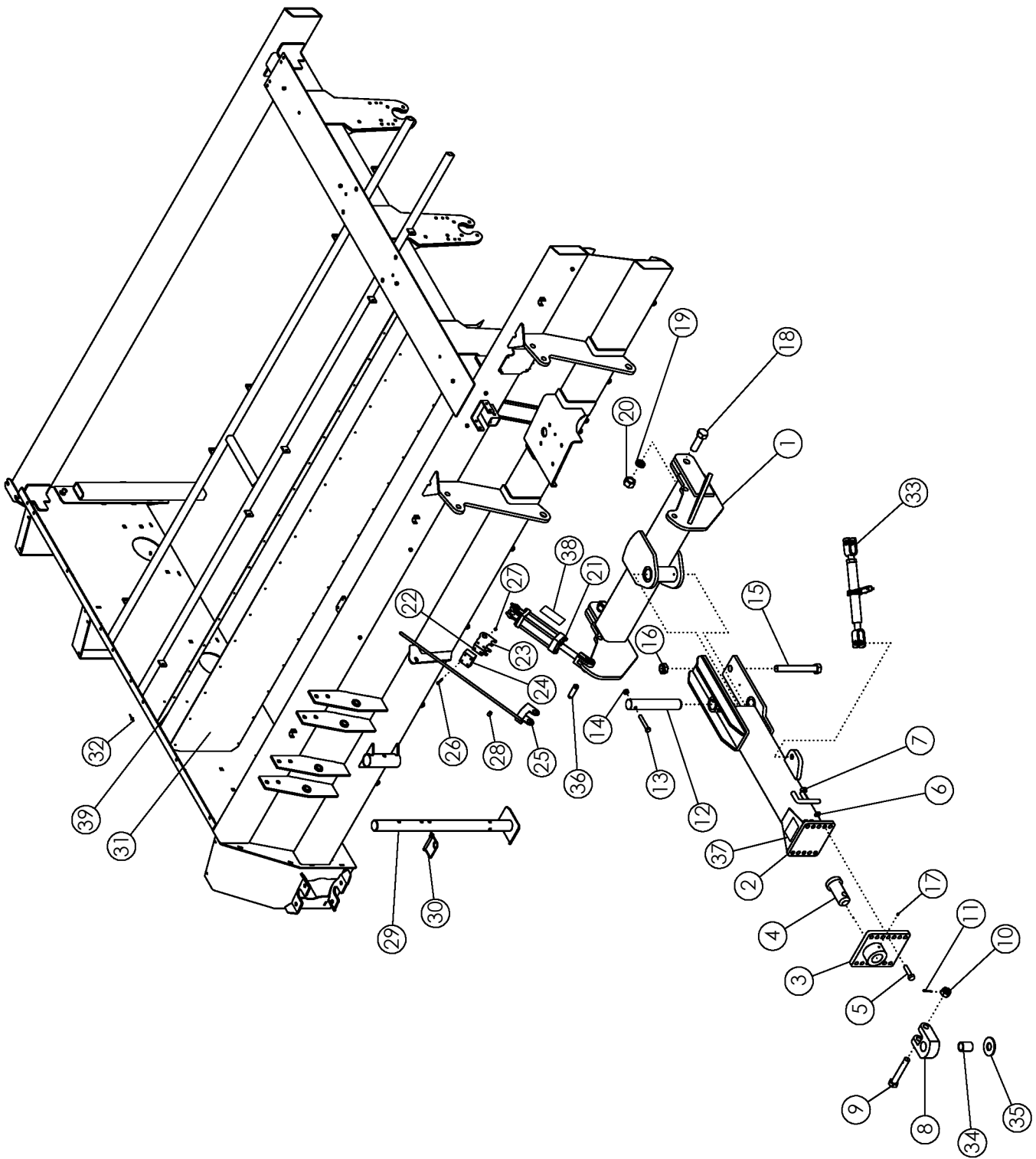

TABLE OF CONTENTS

HITCH ASSEMBLY.....	1-2
DRIVE TRAIN.....	3-4
#1 FLAILS.....	5-14
#2 FLAILS.....	15-22
#3 FLAILS.....	23-38
L KNIFE FLAIL TUBE ASSEMBLY.....	39-40
STEEL FLAIL ASSEMBLY.....	41-44
FLAIL TUBE MOUNTING.....	45-46
FLAIL TUBE MOUNTING - STEEL FRONT DRUM OPTION.....	47-48
DOORS & SHIELDS.....	49-52
SIDE LINER KIT.....	53-54
STANDARD REAR STRUTS - 11.2 X 24 TIRES.....	55-58
STANDARD REAR STRUTS - 7.6 X 15 TIRES.....	59-60
STEERABLE REAR STRUTS - 11.2 X 24 TIRES.....	61-64
STEERABLE REAR STRUTS - 7.6 X 15 TIRES.....	65-68
STEERABLE STRUTS UPPER.....	69-70
STEERABLE REAR STRUTS - 11.2 X 24 - 22" CENTERING.....	71-72
STANDARD-OFFSET 22" WIDE STRUT 11.2 X 24 TIRES.....	73-74
STEERABLE-OFFSET 22" WIDE 2 STRUT 11.2 X 24 TIRES.....	75-76
SCALPER BAR ASSEMBLY.....	77-78
SCALPER BASKET.....	79-80
VALVE BLOCK & MOUNT.....	81-84
SCALPER MOUNTED ROW FINDER 12 ROW.....	85-86
SCALPER MOUNTED ROW FINDER HYDRAULICS.....	84-88
ROW FINDER FRAME MOUNTED.....	89-90
ASSEMBLY DEF ROW FINDER.....	91-92
FRAME MOUNTED ROW FINDER HYDRAULICS.....	93-94
HYDRAULIC ROW FINDER.....	95-98
AHC/FLOATING STRUT VALVES MOUNT (00 SERIES).....	99-100
HITCH HYDRAULICS.....	101-102
LIGHT KIT.....	103-104
DECALS.....	105-108
FRONT STABILIZER STRUT (OPTIONAL).....	109-110
SINGLE ARM STABILIZER WHEEL.....	111-112
STABILIZING HYDRAULICS.....	113-116
REAR STRUT HYDRAULICS - 11.2 X 24 TIRES (OPTIONAL).....	117-118
REAR STRUT HYDRAULICS - 7.6 X 15 TIRES (OPTIONAL).....	119-120
SCALPER HYDRAULICS.....	121-122
ASSEMBLY-TOP DOOR LIFT.....	123-124
FLOATING HITCH KIT.....	125-126
CYLINDER STOP KIT.....	127-128
ACTIVE HEIGHT CONTROL COMPONENTS.....	129-146
GEARBOX-L TYPE #68065.....	147-148
GEARBOX-L TYPE W/OVERRUN CLUTCH #68066.....	149-150
GEARBOX-T TYPE #68067.....	151-152
GEARBOX-T TYPE #68068.....	153-154
PTO STANDARD (1-3/8" & 1-3/4") #306404.....	155-156

CONTINUED...

PTO CONSTANT VELOCITY (1-3/8" & 1-3/4") #69681 & #69682 CLUTCH.....	157-158
TORQUE LIMITER #305196 & 305198.....	159-160
SIDE DRIVELINE #52397.....	161-162
COUPLER UNIVERSAL JOINT.....	163-164
HYDRAULIC LABEL ASSEMBLY.....	165-166
SNAP RING PLIERS.....	167



HITCH ASSEMBLY

ITEM	PART NO.	DESCRIPTION	QTY
1	50341	WLDMT - STD HITCH PIVOT	1
2	68277	WLDMT - DRAWPOLE DEF	1
3	57930	WLDMT-HITCH PLATE	1
4	62101	WLDMT-PIN	1
5	1012059	BOLT-HEX: .75 X 3.00 NC GR5 ZP	6
6	1012061	WASHER-LOCK: .75 ZP	6
7	1011620	NUT-HEX: .75 NC GR2 ZP	6
8	64476	PLATE-PULL HITCH	1
9	62477	BOLT-HITCH DRILLED	1
10	62088	NUT-SLOTTED: 1.13 NC GR5 ZP	1
11	1013473	PIN-COTTER: .19 X 2.00 NP	1
12	50678	PIN	1
13	1015117	BOLT-HEX: .63 X 4.00 NC GR8 ZP	1
14	1016595	NUT-TOPLOCK: .63 NC GR5 ZP	1
15	1030756	BOLT-HEX: 1.25 X 10.50 NC GR5 ZP	1
16	1030759	NUT-TOPLOCK: 1.25 NC ZP	1
17	1011748	ZERK - GREASE	4
18	1030757	BOLT-HEX: 1.38 X 4.25 NC GR5 ZP	2
19	1030760	WASHER-LOCK: 1.38 ZP	2
20	1030758	NUT-HEX: 1.38 NC ZP	2
21	58891	CYLINDER-HYDRAULIC 4 X 8" 3000	2
	301315	SEAL KT-CYL 4 X 8, 4 X 10 3000PSI UNIVERSAL	
22	63995	TOP_BRACKET - RH	1
23	63996	TOP_BRACKET - LH	1
24	63383	POLY GUIDE BLOCK	1
25	63999	WLDMT - BOTTOM_BRACKET	1
26	1016211	BOLT-HEX: .25 X 2.00 NC GR5	4
27	1030946	NUT-TOPLOCK: .25 NC GR5 ZP	4
28	63359	COLLAR-SET: .563 ZP	1
29	52073	WLDMT-STAND	2
30	52408	SPRING PIN .50 X 3.50	2
31	68533	LINER-FRONT 1222	2
32	56886	RIVET-POP: .19 X .675 ZP	68
33	52407	RATCHET JACK-PAINTED	1
34	64615	TUBE-SPACER 2.0 X 1.25	1
	64614	TUBE-SPACER 2.0 X 1.63	
35	58925	WASHER-HARDENED: 4.00 X 1.63	1
	68645	WASHER-FLAT: SPCL 2.125 X 4.50 X .184	
36	63406	PIN-CLEVIS: 1.00 X 4.00 ZP	1
37	52248	DECAL-CAUTION	1
38	63405	DECAL-DEPTH GAUGE	1
39	69106	STRIP-LINER BACK 12R	2
40	58090	SAFETY CHAIN 2020# (NOT SHOWN)	1

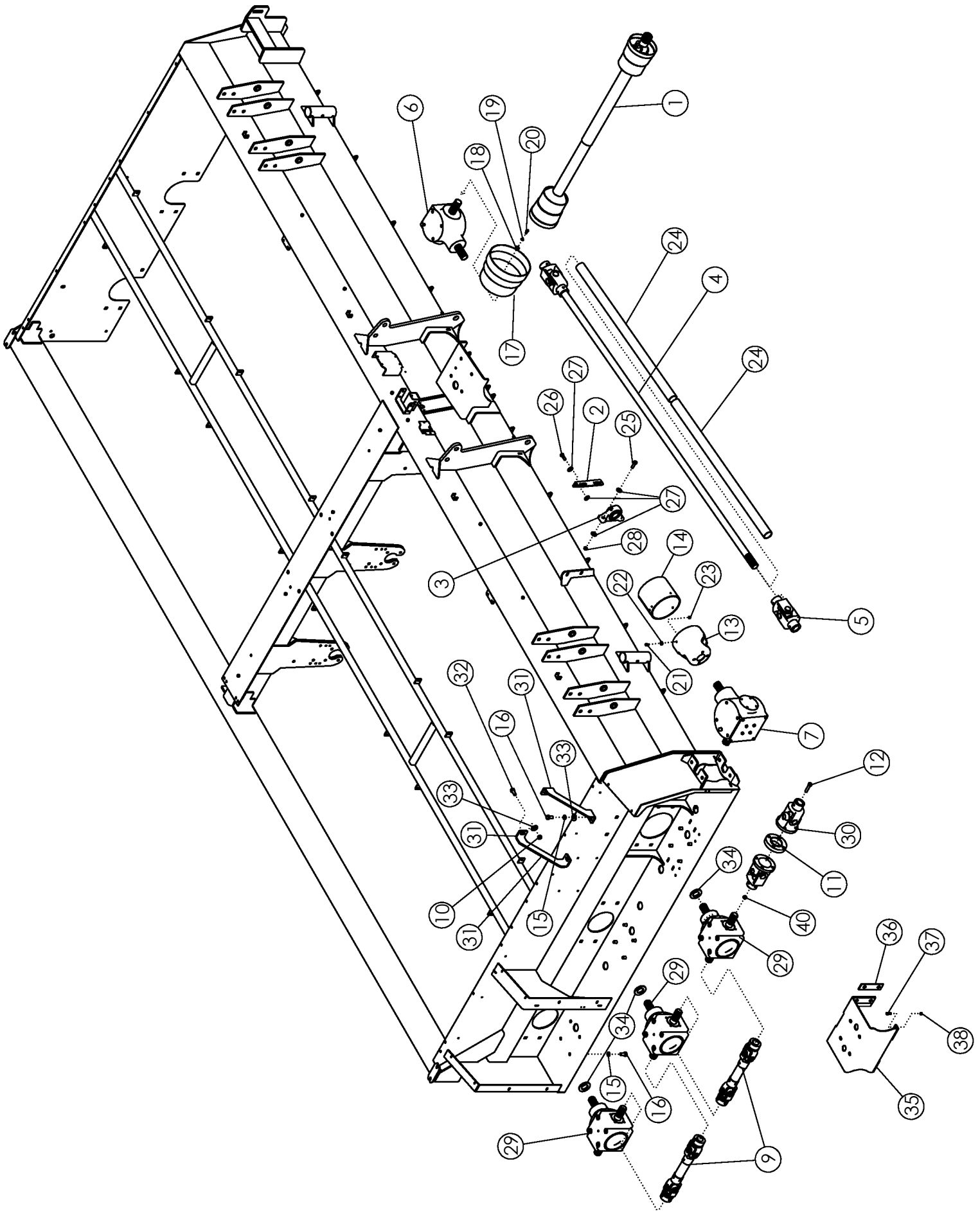

DRIVE TRAIN

ITEM	PART NO.	DESCRIPTION	QTY
1	69681	CONSTANT VELOCITY PTO 1.38"	1
	69682	CONSTANT VELOCITY PTO 1.75"	
	69679	STANDARD PTO 1.38"	
	69680	STANDARD PTO 1.75"	
2	68274	PLATE-BEARING SUPPORT	1
3	52405	BEARING-PILLOW 1-3/4"	1
4	300111	SHAFT-CROSS 12R SPLINED	1
5	69683	U-JOINT 1-3/4"20 SPLINED	2
6	68065	GEARBOX-S2125 1.35:1 L	1
7	68066	GEARBOX-S2125 1.35:1 L W/OVERRUN CLUTCH	1
8	68067	GEARBOX-S2125 1.35:1 T	2
9	52397	DRIVELINE-SIDE	2
10	1016595*	NUT-TOPLOCK: .63 NC GR5 ZP	2
11	305154	PLATE-SPACER COUPLER 90DEG	1
12	305192	BOLT-HEX .56 X3.00 NC GR5 ZP	4
13	63972	SHIELD-CONE SMALL DRILLED	2
14	52372	FLAP-RUBBER INSERT	2
15	1011813	WASHER-LOCK: .63 ZP	22
16	306104	BOLT-HEX: M16 X2.0 XL30 CL 10.9	22
17	52389	SHIELD CONE-LARGE	1
18	1011828	WASHER-FLAT: .38 ZP	12
19	1011586	WASHER-LOCK: .38 ZP	12
20	68450	BOLT-HEX: M10 X1.5 XL20	12
21	1011597	BOLT-HEX: .31 X .75 NC GR5 ZP	8
22	1011583	WASHER-FLAT: .31 ZP	8
23	1030700	NUT-TOPLOCK: .31 NC GR5 ZP	8
24	68275	COVER-CROSS SHAFT 49.50"	2
25	1011608	BOLT-HEX: .50 X 1.75 NC GR5 ZP	2
26	1011607	BOLT-HEX: .50 X 1.50 NC GR5 ZP	2
27	1014443	WASHER-FLAT: .50 ZP	8
28	1027461	NUT-TOPLOCK: .50 NC GR5 ZP	4
29	68067	GEARBOX-S2125 1.35:1 T (NON STEEL FLAIL)	1
	68068	GEARBOX-S2125 1:1.93 T (STEEL FLAIL)	
30	68443	COUPLER-U-JOINT	1
31	68970*	PLATE-GEARBOX SUPPORT	2
32	72063*	BOLT-CRG: .63 X 1.50 NC GR5 ZP	2
33	1013024*	WASHER-FLAT: .63 ZP	4
34	306388	RUBBER-FLAIL TUBE SPACER	6
35	307313	WLDMT-GEARBOX BRACE	1
36	306096	PLATE-GEARBOX BRACE BACKING	2
37	1011600	BOLT-HEX: .38 X 1.00 NC GR5 ZP	4
38	1016999	NUT-TOPLOCK: .38 NC GR5 ZP	4
39	307315	PLATE-DRUM CATCH	1
40	59105	NUT-TOPLOCK: .56 X 3.00 NC GR5 ZP	4

* USE WITH STEEL FRONT DRUM ONLY

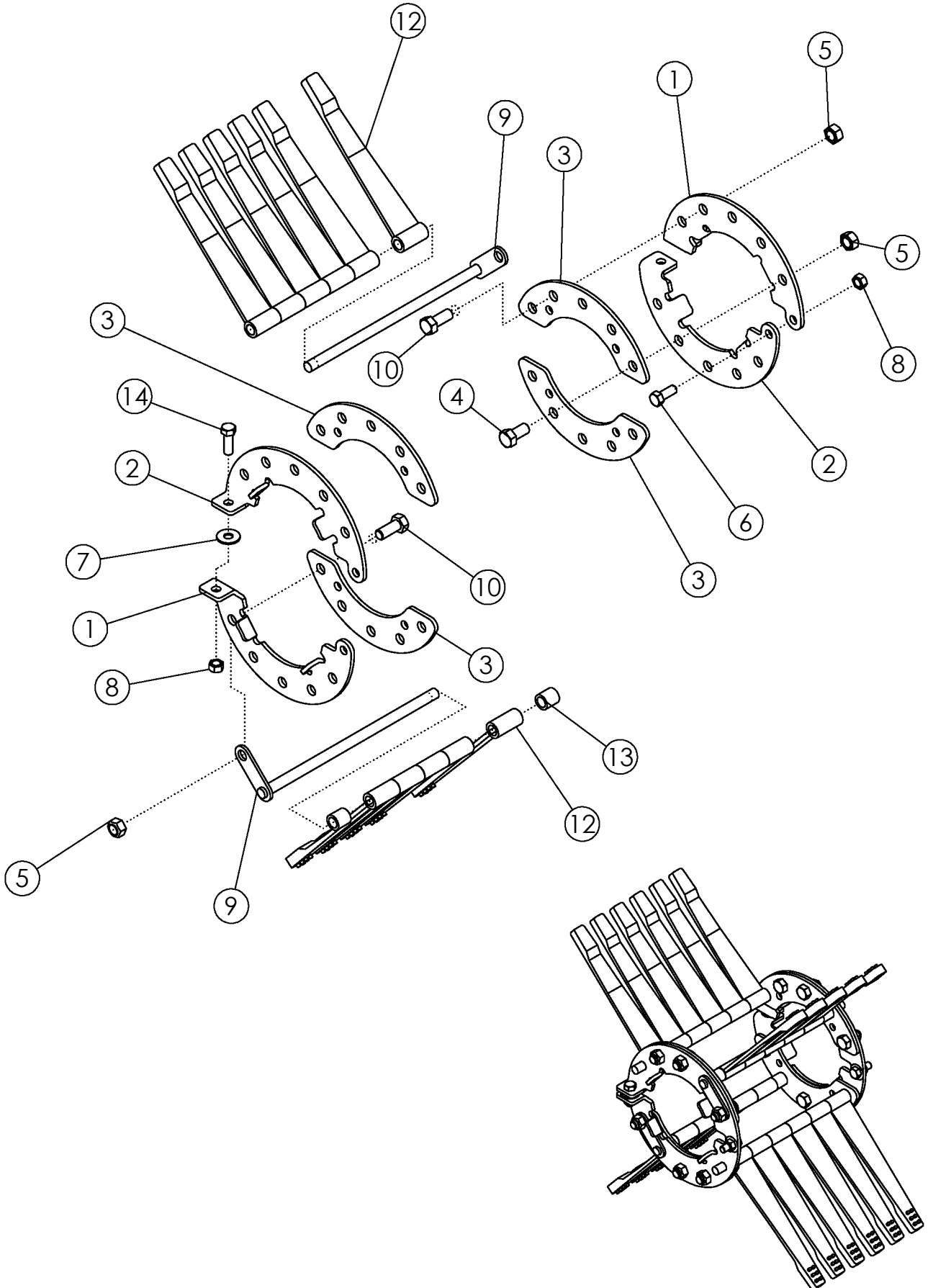

**RUBBER FLAILS ON #1 DRUM FORWARD
22" SPACING (#52123)**

ITEM	PART NO.	DESCRIPTION	QTY
1	52062	FLAIL RING-LH	2
2	52061	FLAIL RING-RH	2
3	58084	PLATE-REINFORCEMENT ZP	4
4	1032509	BOLT-HEX: .63 X 1.25 NC GR5 ZP	8
5	1016595	NUT-TOPLOCK: .63 NC GR5 ZP	12
6	1011606	BOLT-HEX: .50 X 1.25 NC GR5 ZP	2
7	1014443	WASHER-FLAT: .50 ZP	2
8	1027461	NUT-TOPLOCK: .50 NC GR5 ZP	4
9	305557	FLAIL ROD	4
10	1014349	BOLT-HEX: .63 X 1.50 NC GR5 ZP	4
11	1013024	WASHER-FLAT: .63 ZP	4
12	52356	FLAIL-STUDDDED 1 X 12	22
13	51549	SPACER 1	4
14	1011607	BOLT-HEX: .50 X 1.50 NC GR5 ZP	2

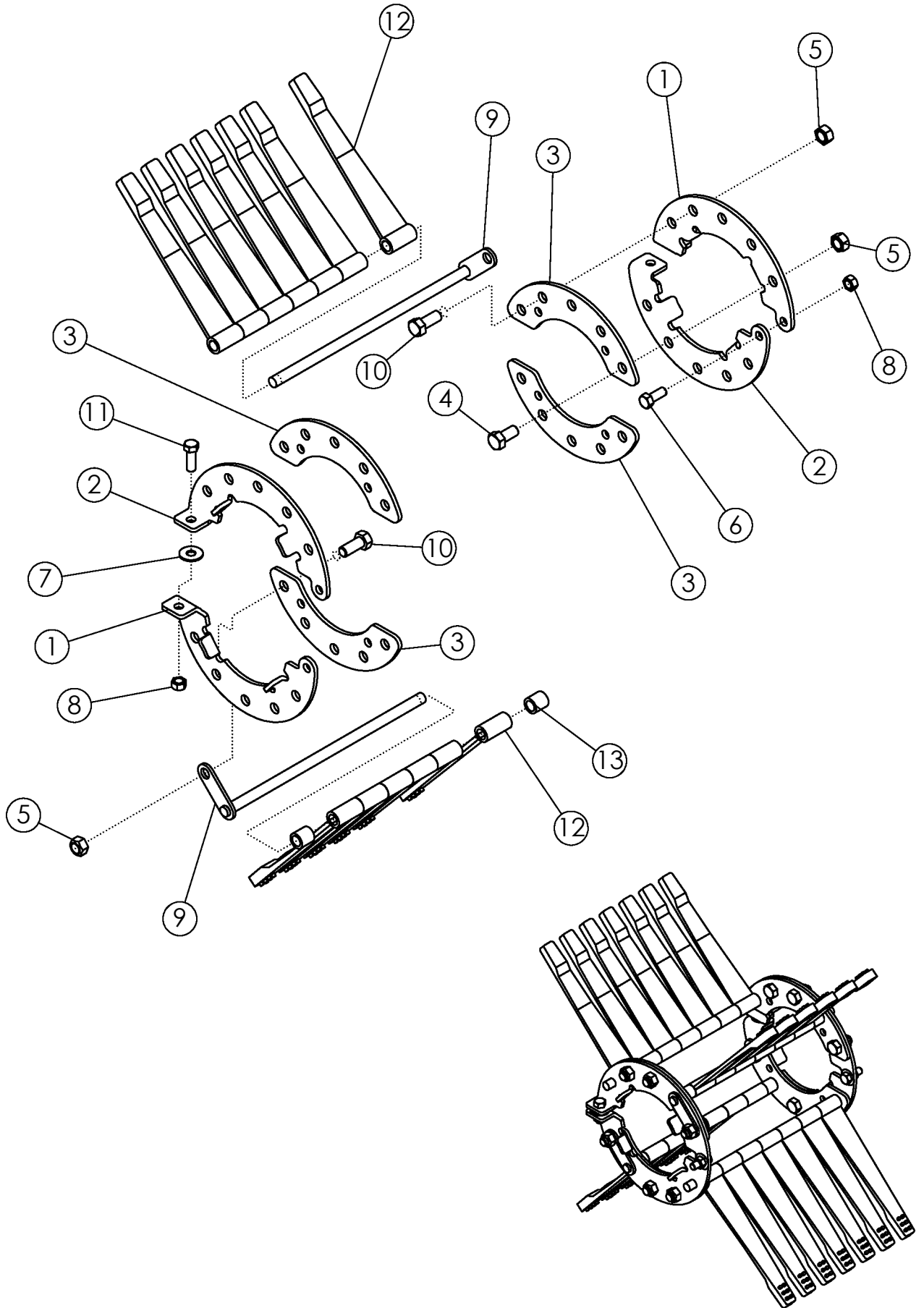

RUBBER FLAILS ON #1 DRUM FORWARD 30" SPACING

ITEM	PART NO.	DESCRIPTION	QTY
1	52062	FLAIL RING-LH	2
2	52061	FLAIL RING-RH	2
3	58084	PLATE-REINFORCEMENT ZP	4
4	1032509	BOLT-HEX: .63 X 1.25 NC GR5 ZP	8
5	1016595	NUT-TOPLOCK: .63 NC GR5 ZP	12
6	1011606	BOLT-HEX: .50 X 1.25 NC GR5 ZP	2
7	1014443	WASHER-FLAT: .50 ZP	2
8	1027461	NUT-TOPLOCK: .50 NC GR5 ZP	4
9	305556	FLAIL ROD	4
10	1014349	BOLT-HEX: .63 X 1.50 NC GR5 ZP	4
11	1011607	BOLT-HEX: .50 X 1.50 NC GR5 ZP	2
12	52356	FLAIL-STUDDDED 1 X 12	26
	52354	FLAIL-RUBBER 1 X 12 (PREMIER)	
	307261	FLAIL-RUBBER 2 X 12	
13	51549	SPACER 1	4

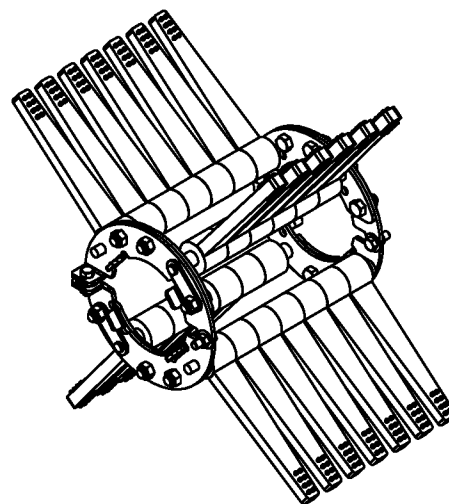
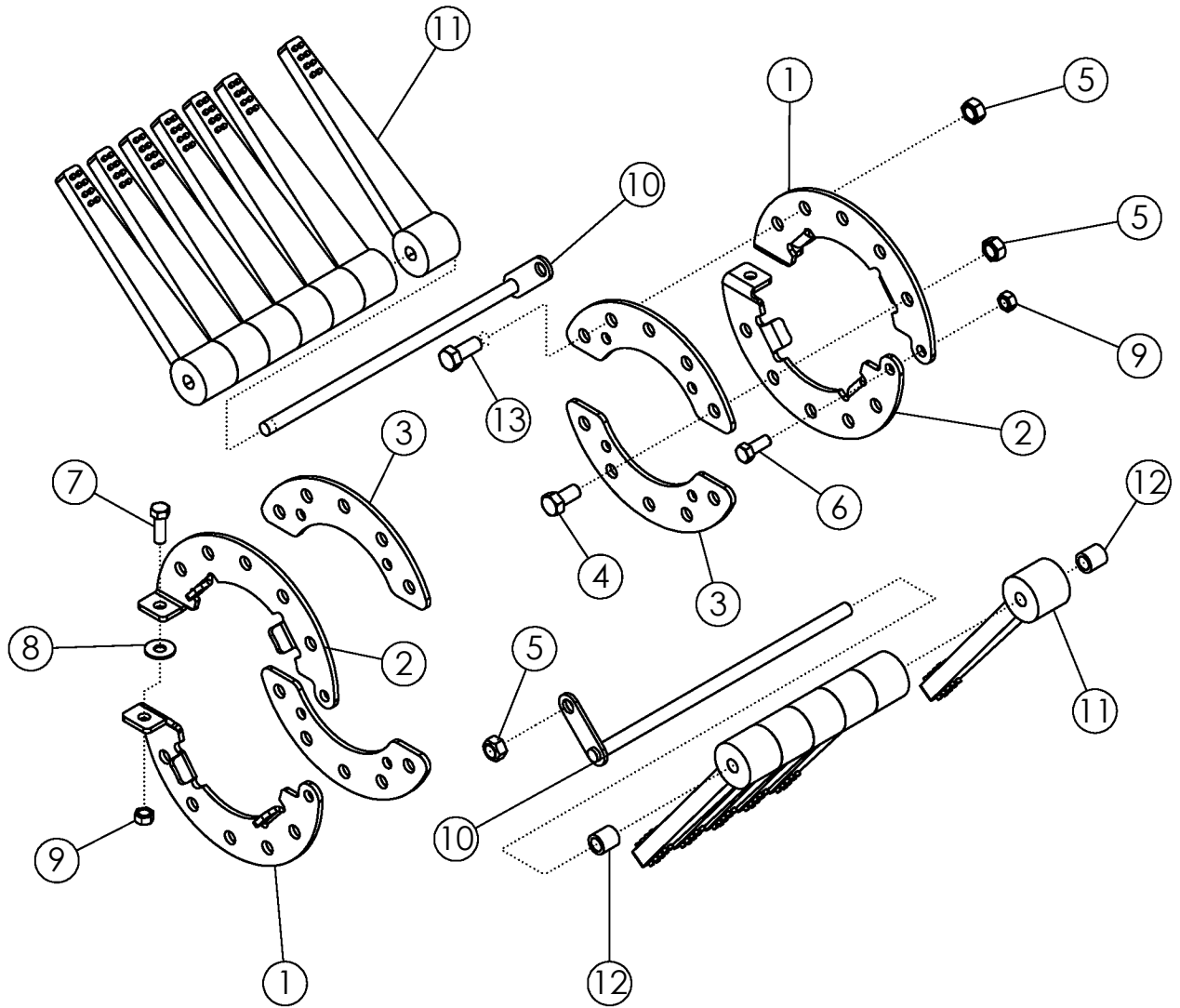

FLAILS ON #1 DRUM 30" #64327

ITEM	PART NO.	DESCRIPTION	QTY
1	52062	FLAIL RING LH - ZP	2
2	52061	FLAIL RING RH - ZP	2
3	58084	PLATE-REINFORCEMENT ZP	4
4	1032509	BOLT-HEX: .63 X 1.25 NC GR5 ZP	8
5	1016595	NUT-TOPLOCK: .63 NC GR5 ZP	12
6	1011606	BOLT-HEX: .50 X 1.25 NC GR5 ZP	2
7	1011607	BOLT-HEX: .50 X 1.50 NC GR5 ZP	2
8	1014443	WASHER-FLAT: .50 ZP	2
9	1027461	NUT-TOPLOCK: .50 NC GR5 ZP	4
10	305556	WLDMT-6 FLAIL ROD 15.75" ZP	4
11	307259	FLAIL-RUBBER 1 X 12 TAPERED	26
12	51549	SPACER-1"	4
13	1014349	BOLT-HEX: .63 X 1.50 NC GR5 ZP	4

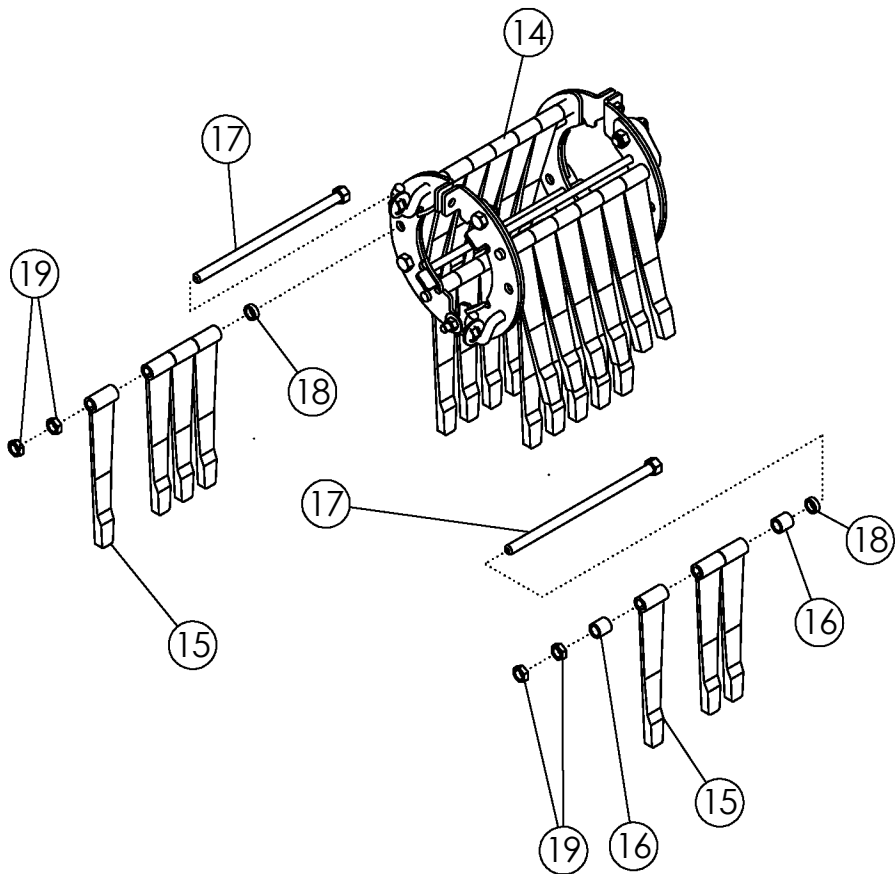
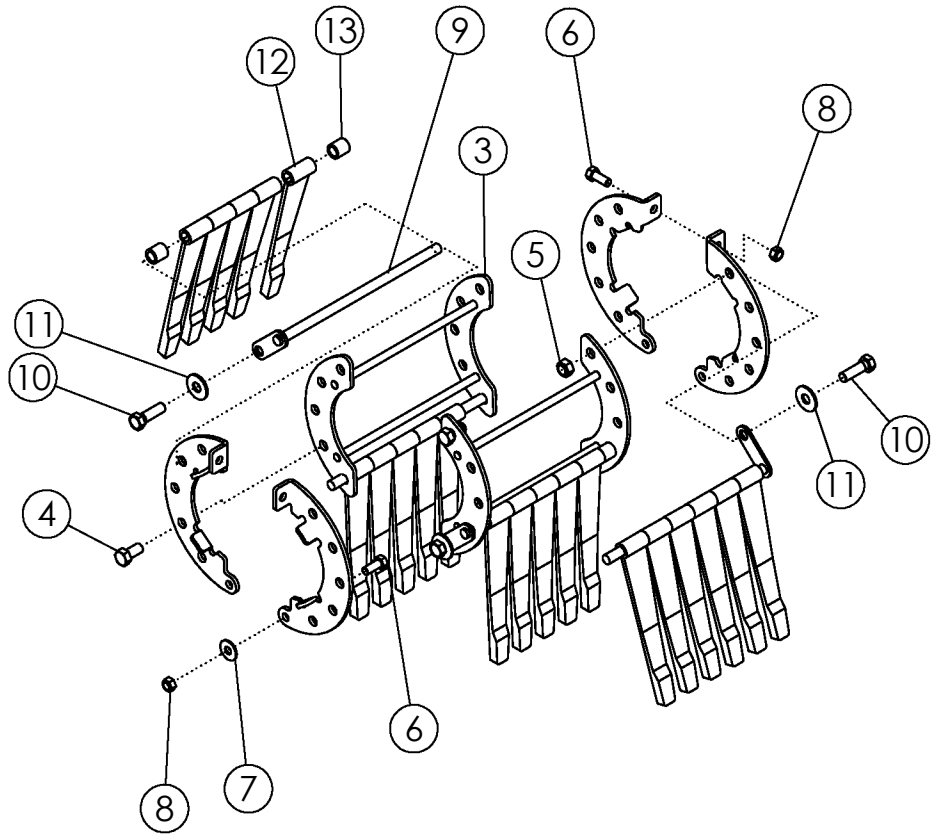

RUBBER FLAILS ON #1 DRUM REVERSE 22" SPACING

ITEM	PART NO.	DESCRIPTION	QTY
1	52062	FLAIL RING-LH	2
2	52061	FLAIL RING-RH	2
3	58167	WLDMT-FRONT BAIL	2
4	1032509	BOLT-HEX: .63 X 1.25 NC GR5 ZP	4
5	1016595	NUT-TOPLOCK: .63 NC GR5 ZP	8
6	1011606	BOLT-HEX: .50 X 1.25 NC GR5 ZP	4
7	1014443	WASHER-FLAT: .50 ZP	2
8	1027461	NUT-TOPLOCK: .50 NC GR5 ZP	4
9	305557	FLAIL ROD	4
10	1011623	BOLT-HEX: .63 X 2.00 NC GR5 ZP	4
11	1013024	WASHER-FLAT: .63 ZP	4
12	52356	FLAIL-STUDDDED 1 X 12	22
13	51549	SPACER 1	4
IN BETWEEN ROWS: 22" SPACING			
14	58542*	ASSY-FLAIL #1 22" REVERSE	1
15	52356	FLAIL-STUDDDED 1 X 12	7
16	51549	SPACER 1	2
17	64600	WLDMT-FLAIL ROD REVERSE 22"	2
18	51547	SPACER 5/16	2
19	1026259	NUT-JAM: .63 NC GR2 ZP	4

*ITEMS ARE 1-13 ARE INCLUDED IN ITEM 14

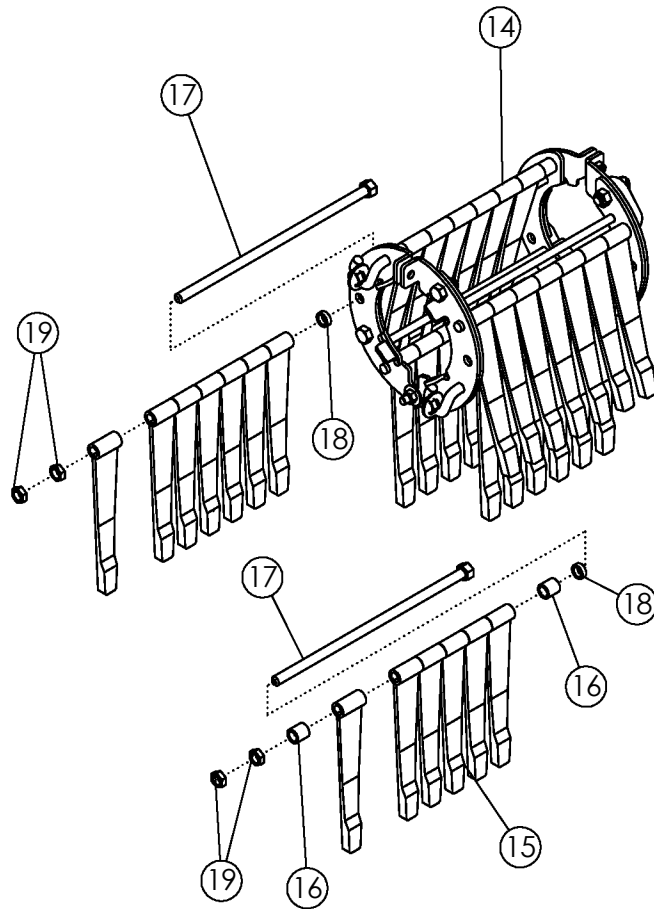
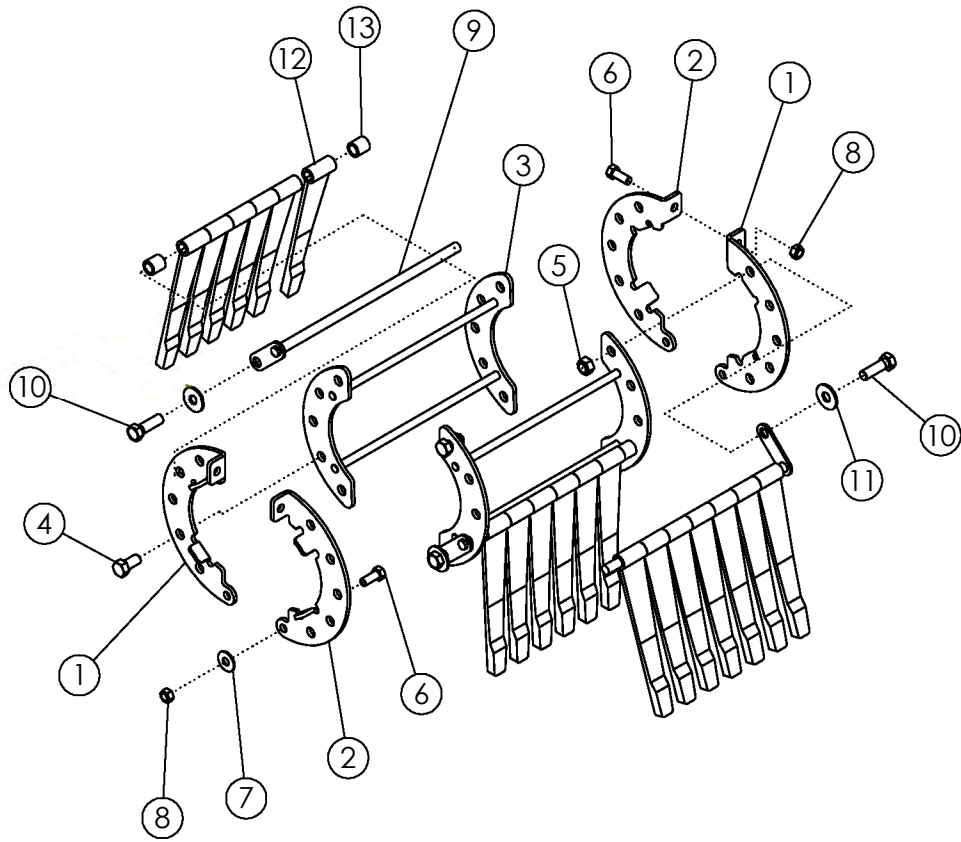

RUBBER FLAILS ON #1 DRUM REVERSE 30" SPACING

ITEM	PART NO.	DESCRIPTION	QTY
1	52062	FLAIL RING-LH	2
2	52061	FLAIL RING-RH	2
3	62254	WLDMT-FRONT BAIL	2
4	1032509	BOLT-HEX: .63 X 1.25 NC GR5 ZP	4
5	1016595	NUT-TOPLOCK: .63 NC GR5 ZP	8
6	1011606	BOLT-HEX: .50 X 1.25 NC GR5 ZP	4
7	1014443	WASHER-FLAT: .50 ZP	2
8	1027461	NUT-TOPLOCK: .50 NC GR5 ZP	4
9	305556	WLDMT-6 FLAIL ROD 15.75" ZP	4
10	1011623	BOLT-HEX: .63 X 2.00 NC GR5 ZP	4
11	1013024	WASHER-FLAT: .63 ZP	4
12	52356	FLAIL-STUDDDED 1 X 12	26
13	51549	SPACER 1	4
IN BETWEEN ROWS: 30" SPACING			
14	58543*	ASSY-FLAIL #1 30" REVERSE	1
15	52356	FLAIL-STUDDDED 1 X 12	13
16	51549	SPACER 1	2
17	64755	WLDMT-FLAIL ROD REVERSE 30"	2
18	51547	SPACER 5/16	2
19	1026259	NUT-JAM: .63 NC GR2 ZP	4

*ITEMS ARE 1-13 ARE INCLUDED IN ITEM 14

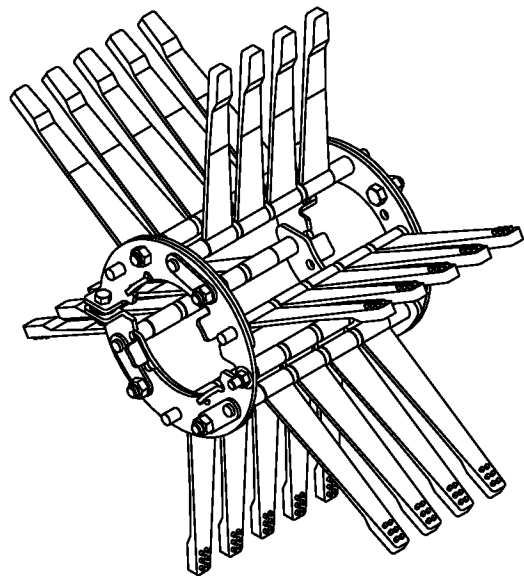
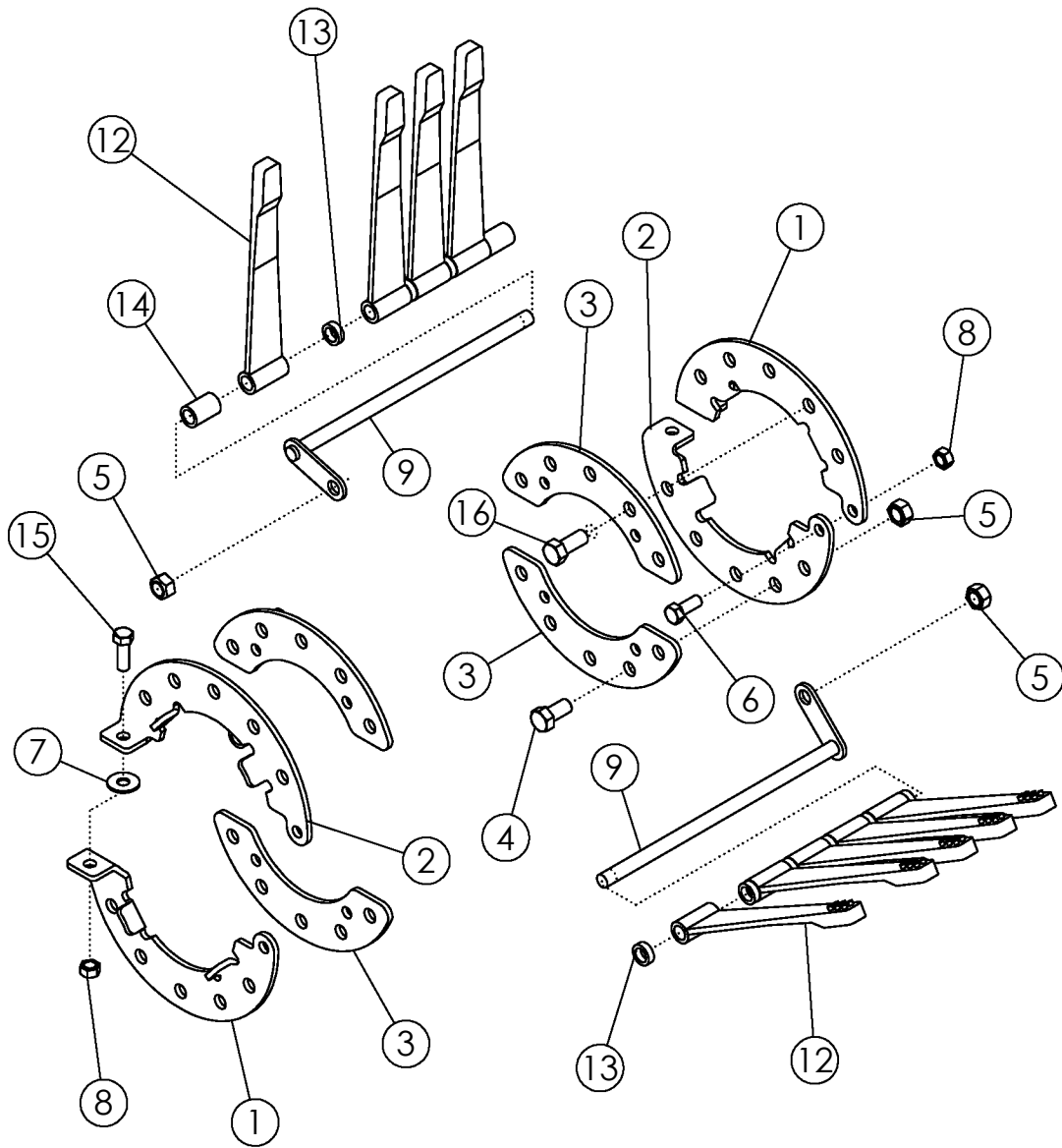

FLAILS ON #2 DRUM

ITEM	PART NO.	DESCRIPTION	QTY
1	52062	FLAIL RING-LH	2
2	52061	FLAIL RING-RH	2
3	58084	PLATE-REINFORCEMENT ZP	4
4	1032509	BOLT-HEX: .63 X 1.25 NC GR5 ZP	2
5	1016595	NUT-TOPLOCK: .63 NC GR5 ZP	8
6	1011606	BOLT-HEX: .50 X 1.25 NC GR5 ZP	2
7	1014443	WASHER-FLAT: .50 ZP	2
8	1027461	NUT-TOPLOCK: .50 NC GR5 ZP	4
9	305557	FLAIL ROD	6
10	1011623	BOLT-HEX: .63 X 2.00 NC GR5 ZP	6
11	1013024	WASHER-FLAT: .63 ZP	6
12	52356	FLAIL-STUDDDED 1 X 12	27
	52354	FLAIL-RUBBER 1 X 12 (PREMIER)	27
13	51547	SPACER 5/16	27
14	51548	SPACER 1-7/16	6
15	1011607	BOLT-HEX: .50 X 1.50 NC GR5 ZP	2
16	1014349	BOLT-HEX: .63 X 1.50 NC GR5 ZP	6

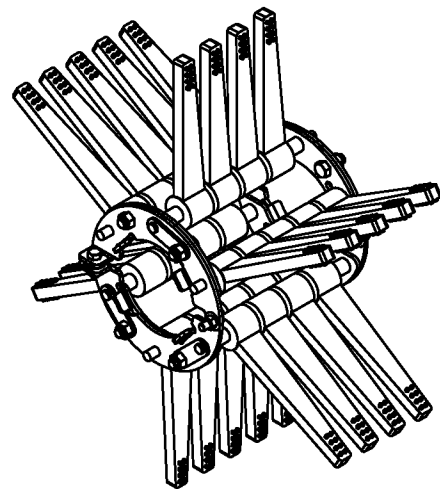
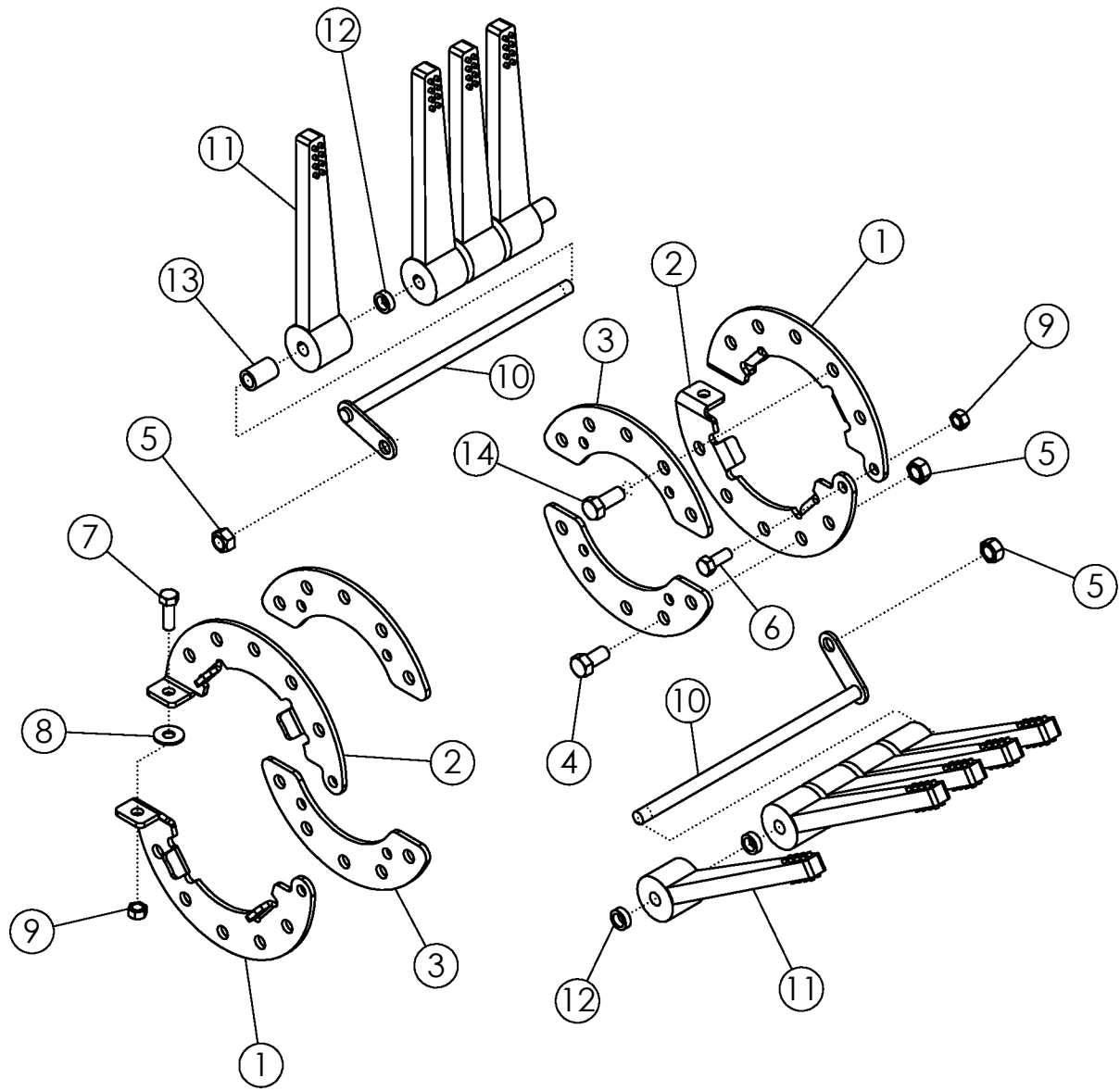

FLAILS ON #2 DRUM 22" #64046

ITEM	PART NO.	DESCRIPTION	QTY
1	52062	FLAIL RING LH - ZP	2
2	52061	FLAIL RING RH - ZP	2
3	58084	PLATE-REINFORCEMENT ZP	4
4	1032509	BOLT-HEX: .63 X 1.25 NC GR5 ZP	2
5	1016595	NUT-TOPLOCK: .63 NC GR5 ZP	8
6	1011606	BOLT-HEX: .50 X 1.25 NC GR5 ZP	2
7	1011607	BOLT-HEX: .50 X 1.50 NC GR5 ZP	2
8	1014443	WASHER-FLAT: .50 ZP	2
9	1027461	NUT-TOPLOCK: .50 NC GR5 ZP	4
10	305557	WLDMT-6 FLAIL ROD 13.875" ZP	6
11	307259	FLAIL-RUBBER 1 X 12 TAPERED	27
12	51547	SPACER-5/16"	27
13	51548	SPACER 1-7/16"	6
14	1014349	BOLT-HEX: .63 X 1.50 NC GR5 ZP	6

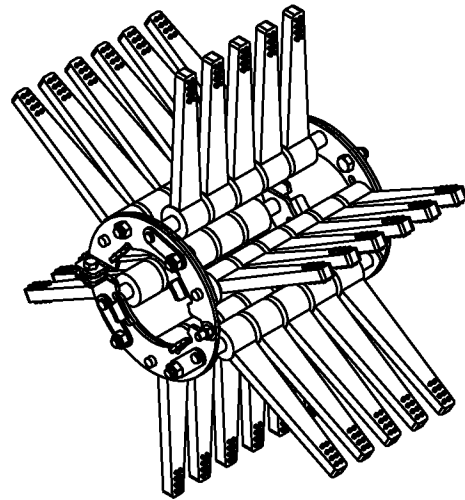
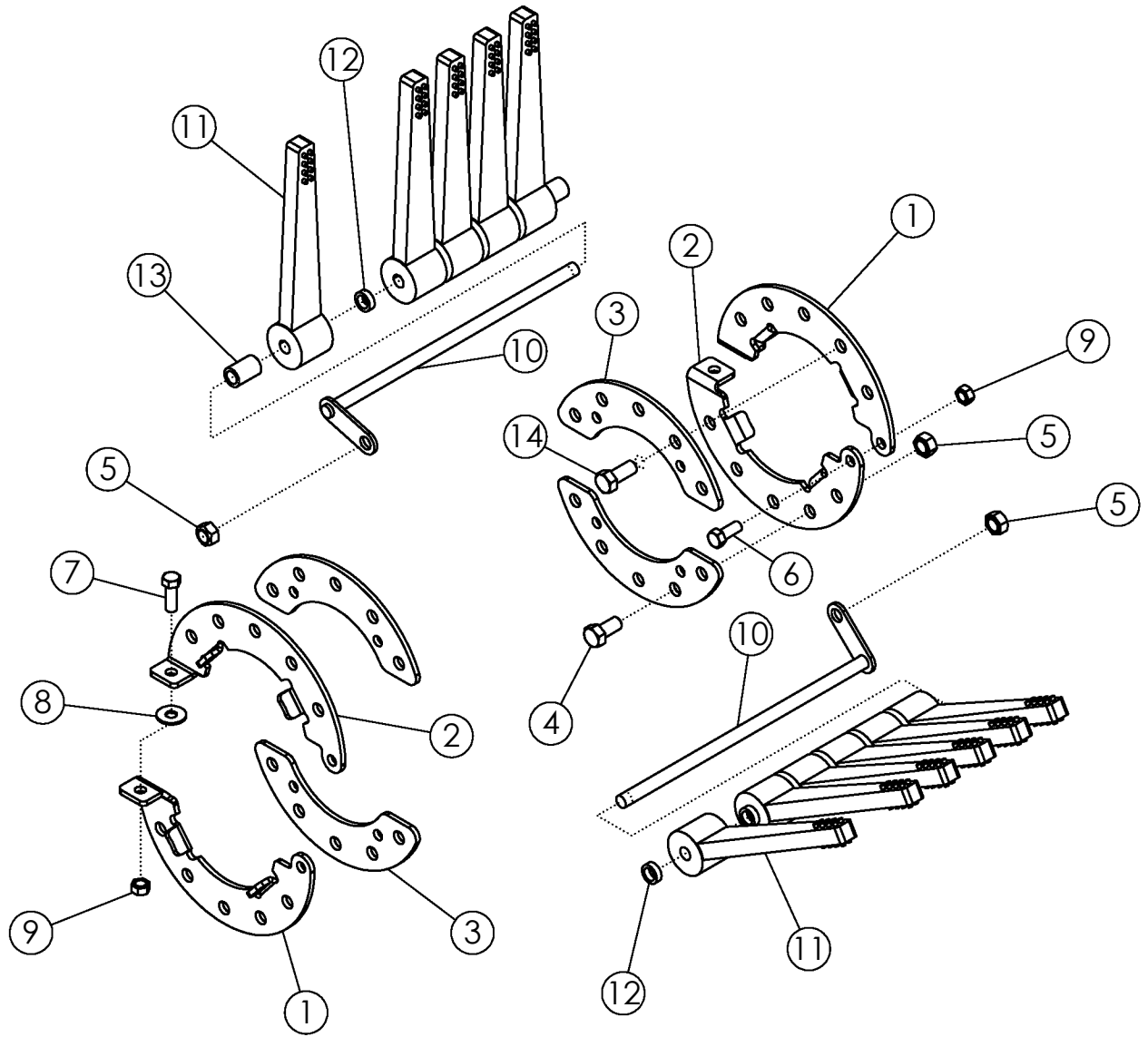

FLAILS ON #2 DRUM 22" #64046

ITEM	PART NO.	DESCRIPTION	QTY
1	52062	FLAIL RING LH - ZP	2
2	52061	FLAIL RING RH - ZP	2
3	58084	PLATE-REINFORCEMENT ZP	4
4	1032509	BOLT-HEX: .63 X 1.25 NC GR5 ZP	2
5	1016595	NUT-TOPLOCK: .63 NC GR5 ZP	8
6	1011606	BOLT-HEX: .50 X 1.25 NC GR5 ZP	2
7	1011607	BOLT-HEX: .50 X 1.50 NC GR5 ZP	2
8	1014443	WASHER-FLAT: .50 ZP	2
9	1027461	NUT-TOPLOCK: .50 NC GR5 ZP	4
10	305556	WLDMT-6 FLAIL ROD 15.75" ZP	6
11	307259	FLAIL-RUBBER 1 X 12 TAPERED	33
12	51547	SPACER-5/16"	33
13	51548	SPACER 1-7/16"	6
14	1014349	BOLT-HEX: .63 X 1.50 NC GR5 ZP	6

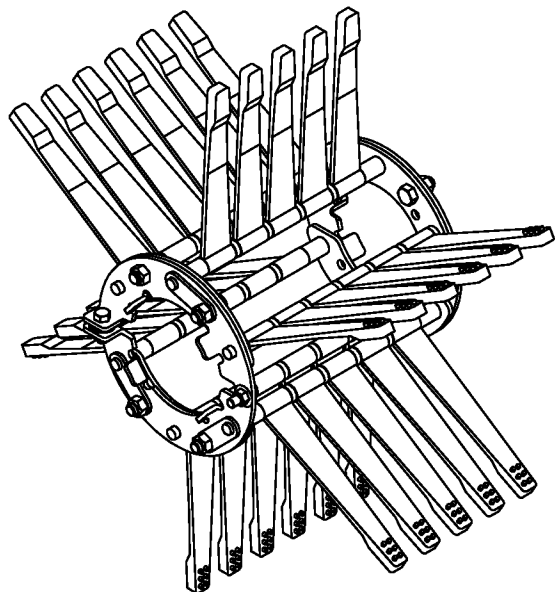
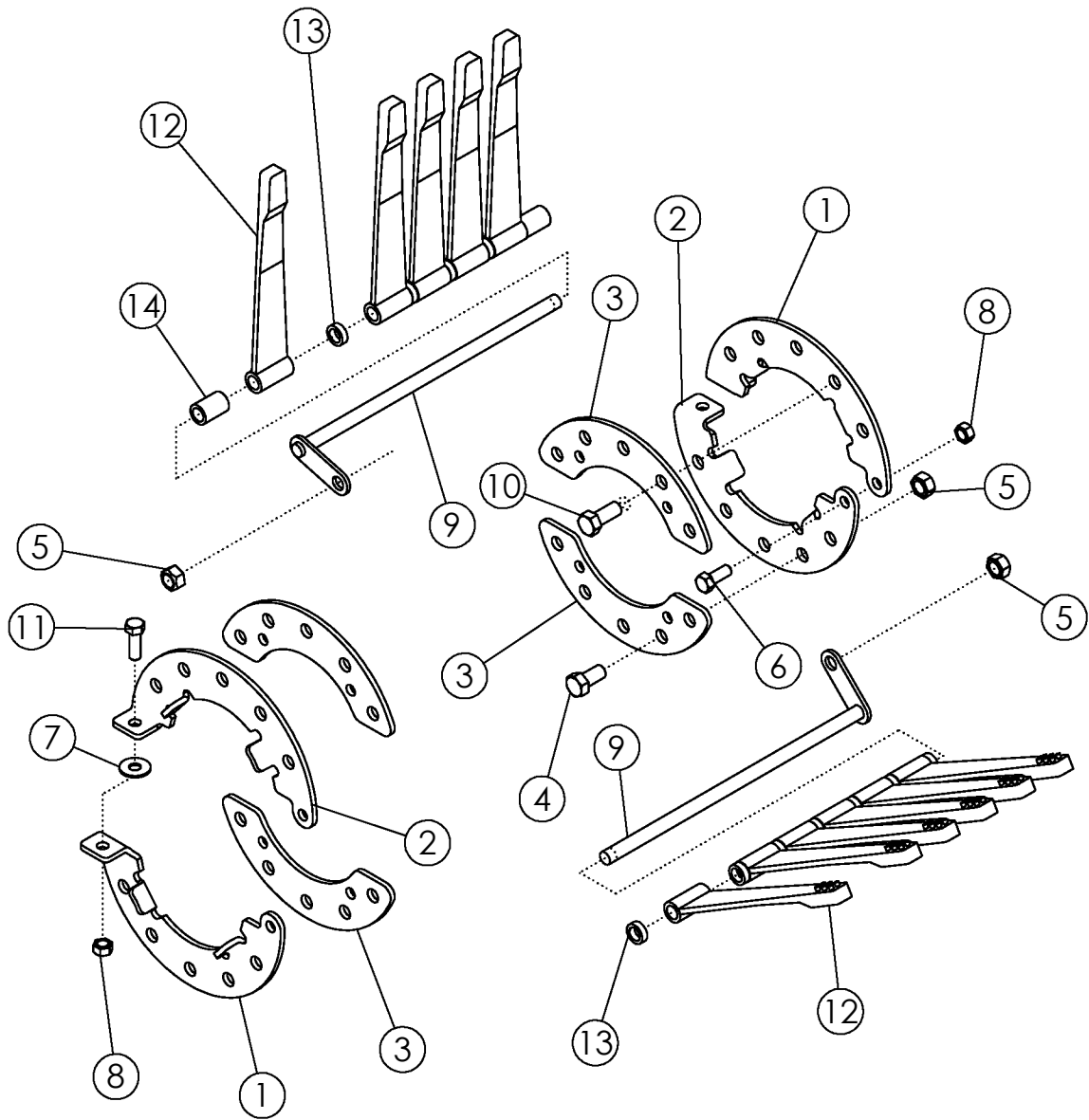

FLAILS ON #2 DRUM 30" SPACING

ITEM	PART NO.	DESCRIPTION	QTY
1	52062	FLAIL RING-LH	2
2	52061	FLAIL RING-RH	2
3	58084	PLATE-REINFORCEMENT ZP	4
4	1032509	BOLT-HEX: .63 X 1.25 NC GR5 ZP	2
5	1016595	NUT-TOPLOCK: .63 NC GR5 ZP	8
6	1011606	BOLT-HEX: .50 X 1.25 NC GR5 ZP	2
7	1014443	WASHER-FLAT: .50 ZP	2
8	1027461	NUT-TOPLOCK: .50 NC GR5 ZP	4
9	305556	WLDMT-6 FLAIL ROD 15.75" ZP	6
10	1014349	BOLT-HEX: .63 X 1.50 NC GR5 ZP	6
11	1011607	BOLT-HEX: .50 X 1.50 NC GR5 ZP	2
12	52356	FLAIL-STUDED 1 X 12	33
	52354	FLAIL-RUBBER 1 X 12 (PREMIER)	33
13	51547	SPACER 5/16	33
14	51548	SPACER 1-7/16	6

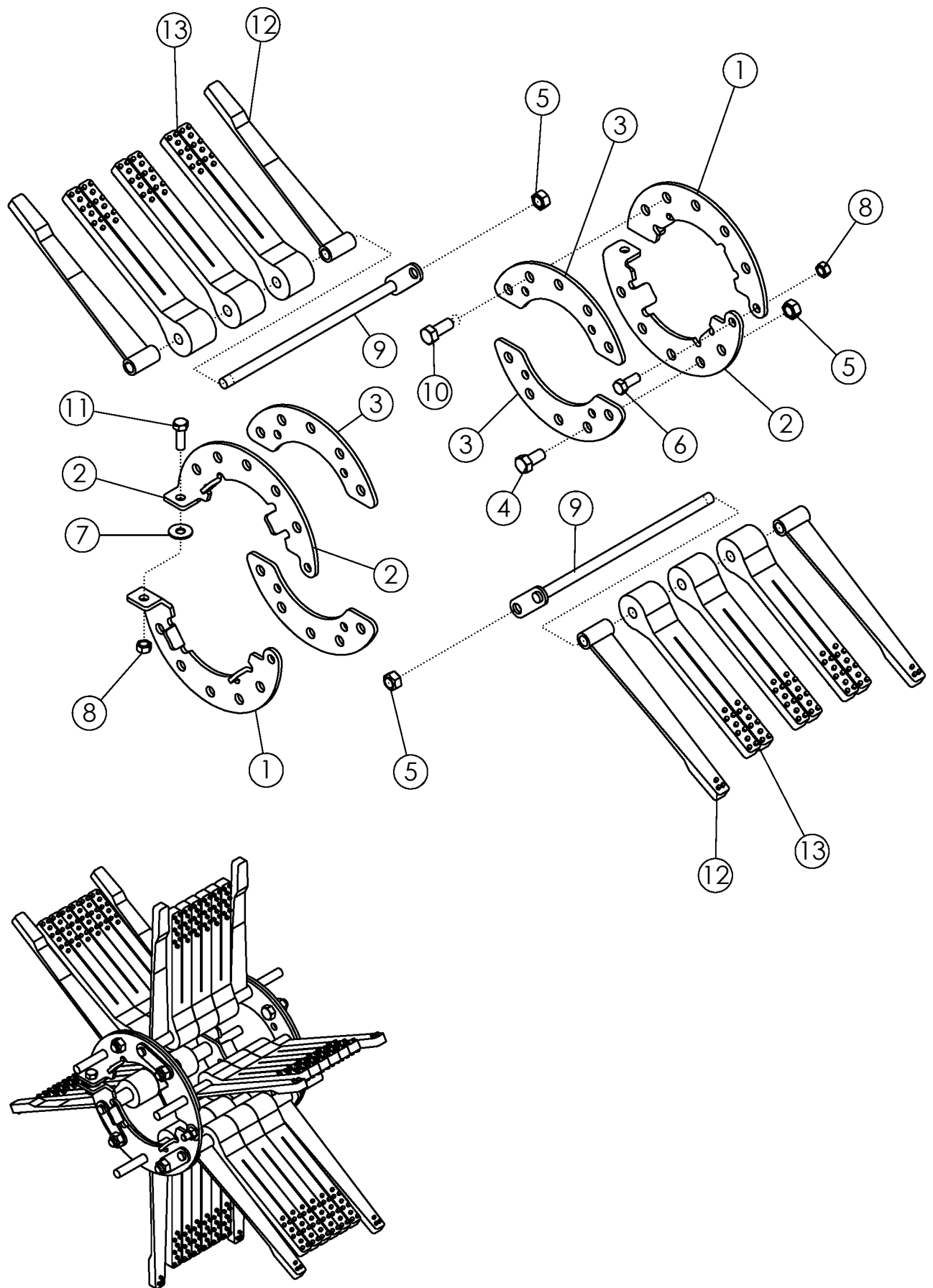

FLAILS ON #3 DRUM 22" #52125

ITEM	PART NO.	DESCRIPTION	QTY
1	52062	FLAIL RING-LH	2
2	52061	FLAIL RING-RH	2
3	58084	PLATE-REINFORCEMENT ZP	4
4	1032509	BOLT-HEX: .63 X 1.25 NC GR5 ZP	2
5	1016595	NUT-TOPLOCK: .63 NC GR5 ZP	8
6	1011606	BOLT-HEX: .50 X 1.25 NC GR5 ZP	2
7	1014443	WASHER-FLAT: .50 ZP	2
8	1027461	NUT-TOPLOCK: .50 NC GR5 ZP	4
9	305557	FLAIL ROD	6
10	1014349	BOLT-HEX: .63 X 1.50 NC GR5 ZP	6
11	1011607	BOLT-HEX: .50 X 1.50 NC GR5 ZP	2
12	52355	FLAIL-SWEEP 1 X 13-1/4	12
13	58255	FLAIL-SPLIT TAPER 2 X 12	18
	52356	FLAIL-STUDDER 1 X 12	18

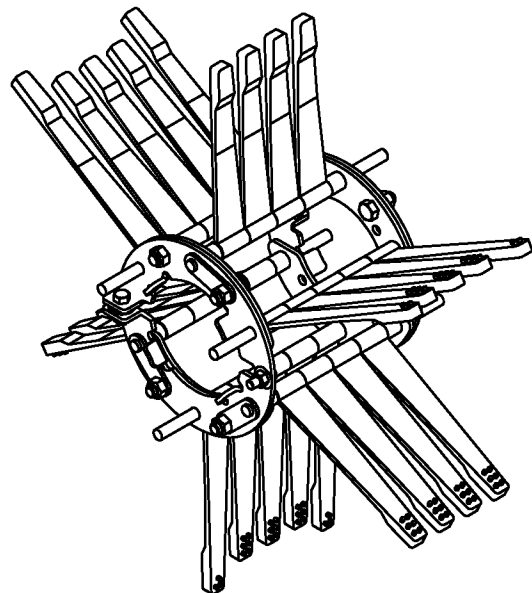
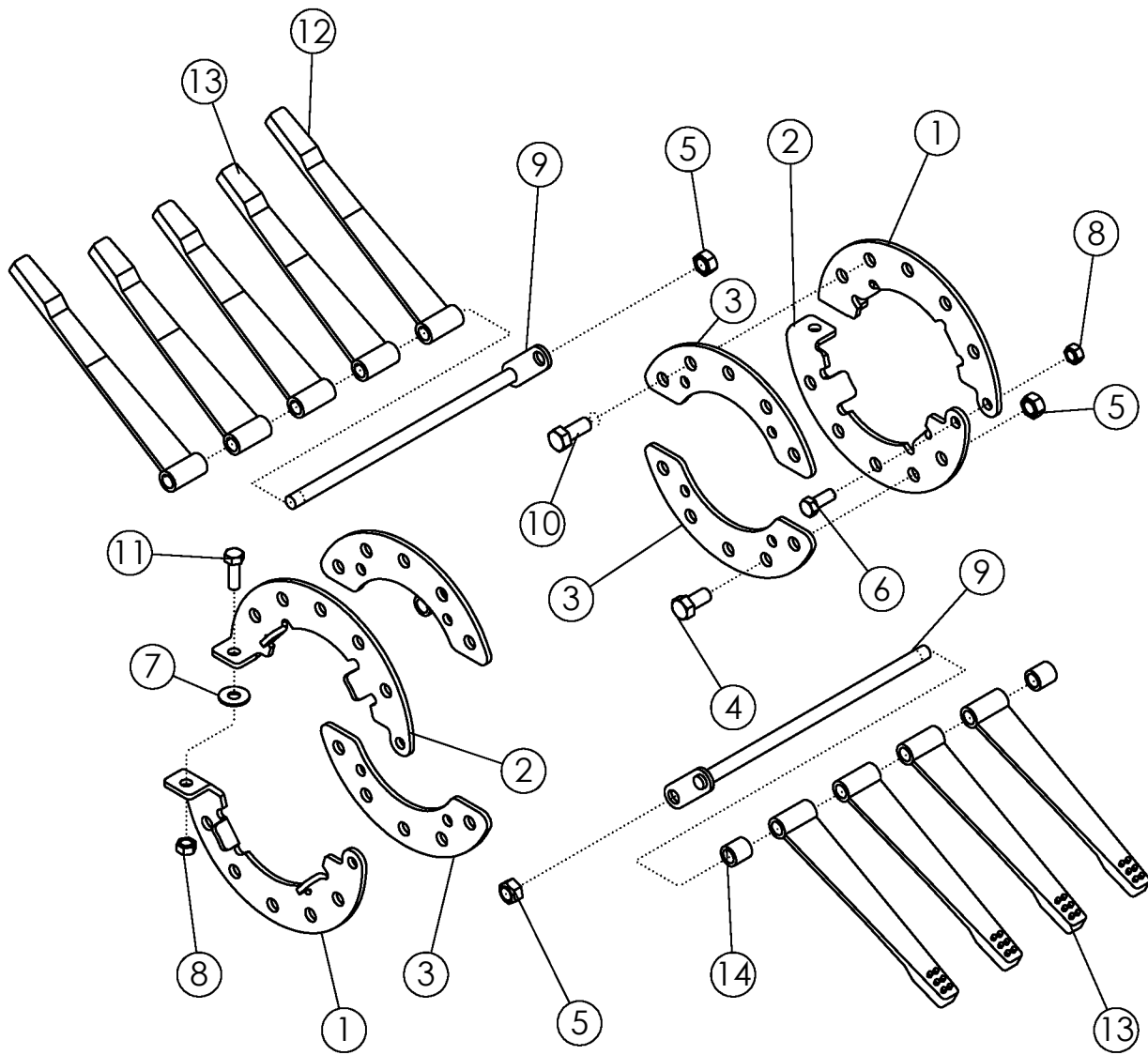

FLAILS ON #3 DRUM 22" #64319

ITEM	PART NO.	DESCRIPTION	QTY
1	52062	FLAIL RING-LH	2
2	52061	FLAIL RING-RH	2
3	58084	PLATE-REINFORCEMENT ZP	4
4	1032509	BOLT-HEX: .63 X 1.25 NC GR5 ZP	2
5	1016595	NUT-TOPLOCK: .63 NC GR5 ZP	8
6	1011606	BOLT-HEX: .50 X 1.25 NC GR5 ZP	2
7	1014443	WASHER-FLAT: .50 ZP	2
8	1027461	NUT-TOPLOCK: .50 NC GR5 ZP	4
9	305557	FLAIL ROD	6
10	1014349	BOLT-HEX: .63 X 1.50 NC GR5 ZP	6
11	1011607	BOLT-HEX: .50 X 1.50 NC GR5 ZP	2
12	52355	FLAIL-SWEEP 1 X 13-1/4	6
13	52356	FLAIL-STUDDER 1 X 12	21
14	51549	SPACER-MEDIUM	6

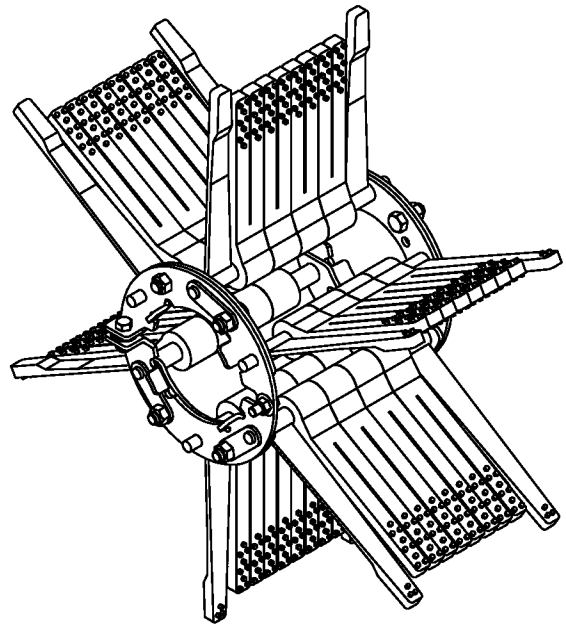
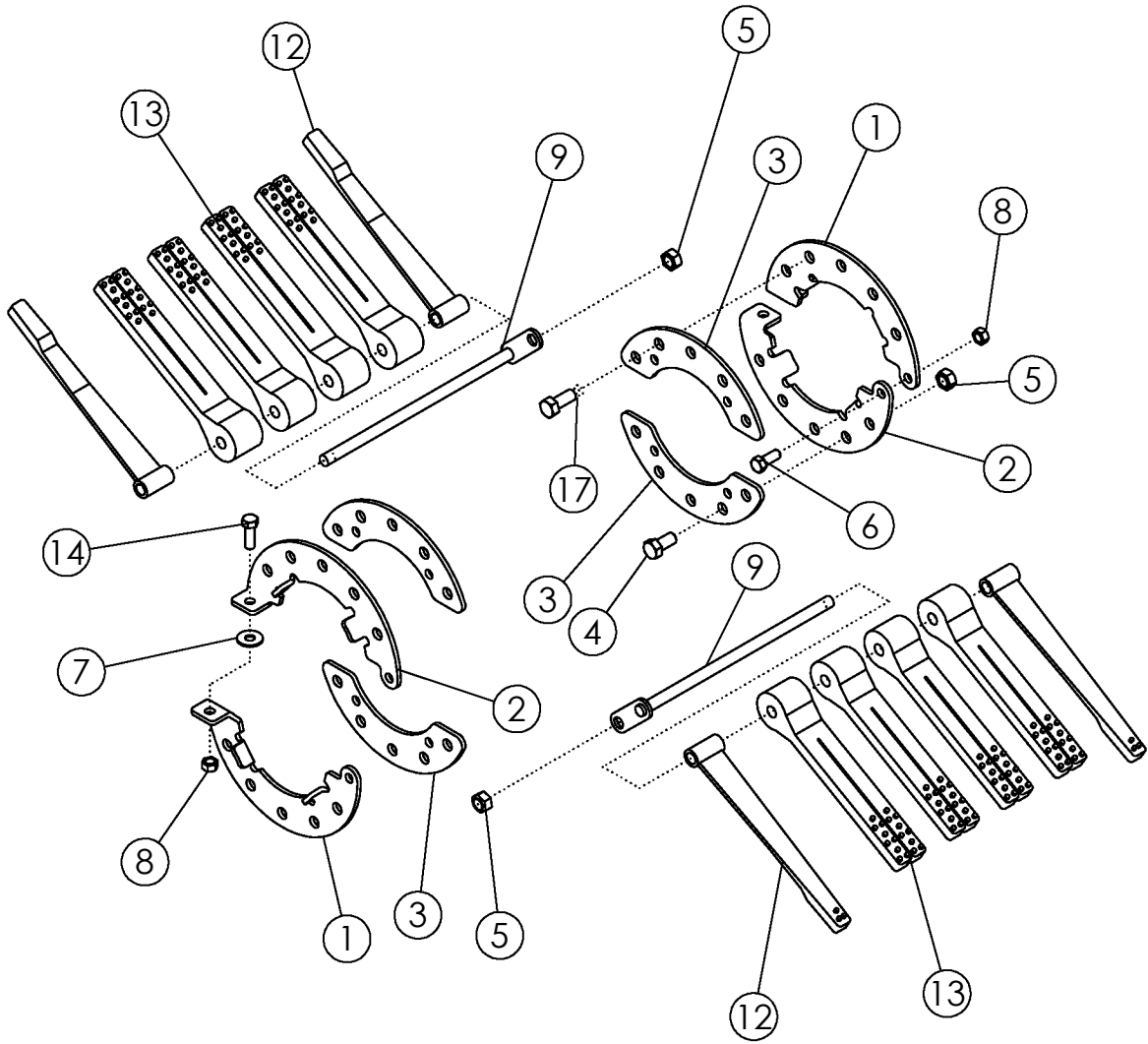

FLAILS ON #3 DRUM 30" SPACING #52128

ITEM	PART NO.	DESCRIPTION	QTY
1	52062	FLAIL RING-LH	2
2	52061	FLAIL RING-RH	2
3	58084	PLATE-REINFORCEMENT ZP	4
4	1032509	BOLT-HEX: .63 X 1.25 NC GR5 ZP	2
5	1016595	NUT-TOPLOCK: .63 NC GR5 ZP	8
6	1011606	BOLT-HEX: .50 X 1.25 NC GR5 ZP	2
7	1014443	WASHER-FLAT: .50 ZP	2
8	1027461	NUT-TOPLOCK: .50 NC GR5 ZP	4
9	305557	FLAIL ROD	6
10	1011623	BOLT-HEX: .63 X 2.00 NC GR5 ZP	6
11	1013024	WASHER-FLAT: .63 ZP	6
12	52355	FLAIL-SWEEP 1 X 13-1/4	12
13	58255	FLAIL-SPLIT TAPER 2 X 12	24
	52354	FLAIL-RUBBER 1 X 12	
14	1011607	BOLT-HEX: .50 X 1.50 NC GR5 ZP	2

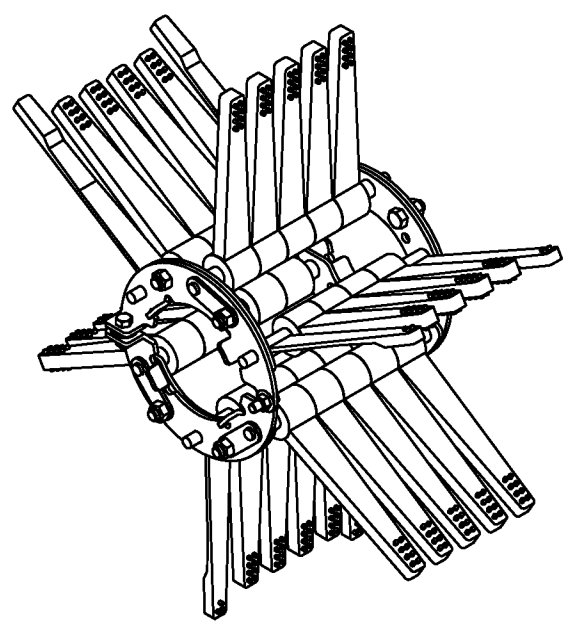
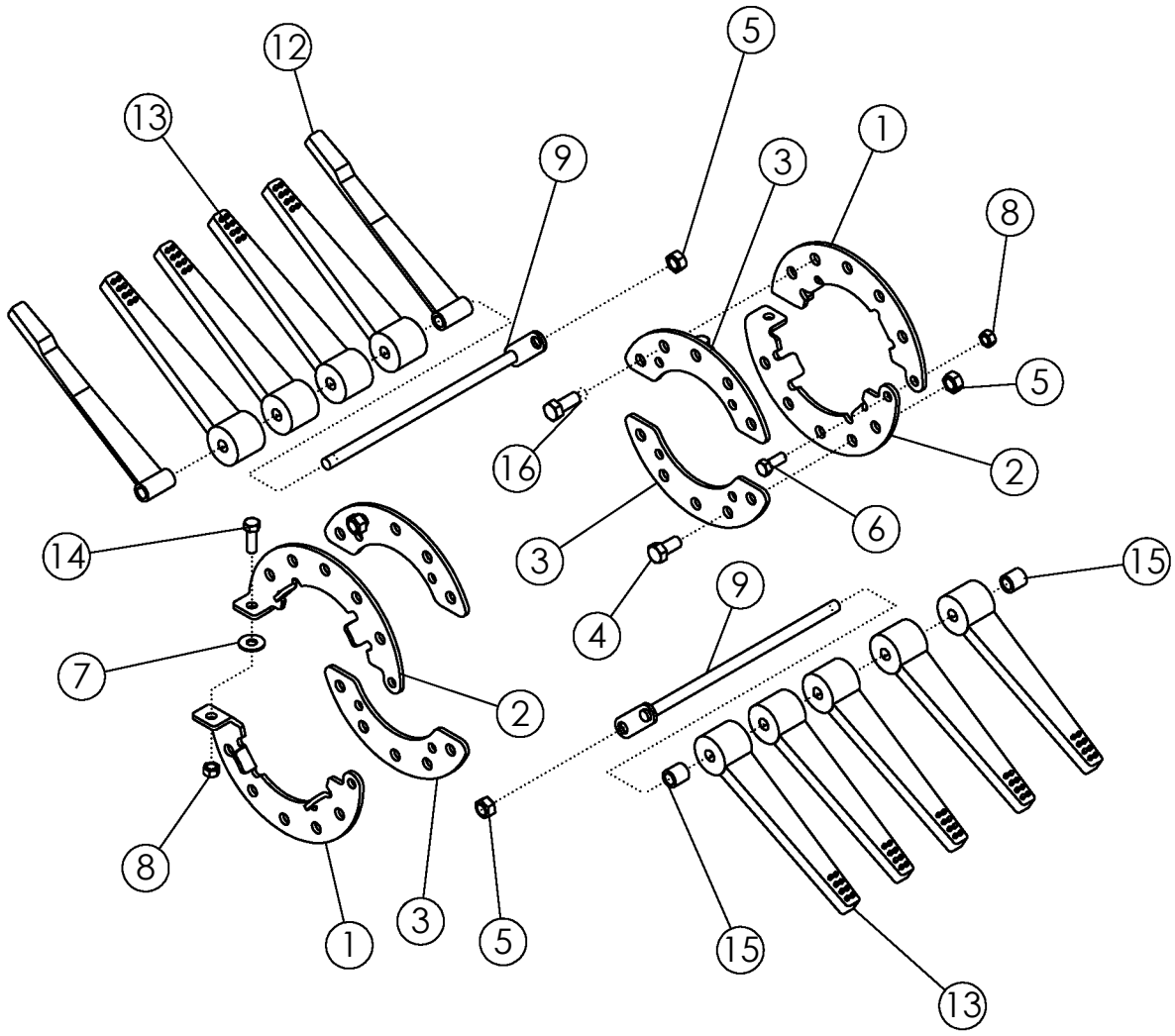

FLAILS ON #3 DRUM 30" SPACING #68796			
ITEM	PART NO.	DESCRIPTION	QTY
1	52062	FLAIL RING-LH	2
2	52061	FLAIL RING-RH	2
3	58084	PLATE-REINFORCEMENT ZP	4
4	1032509	BOLT-HEX: .63 X 1.25 NC GR5 ZP	2
5	1016595	NUT-TOPLOCK: .63 NC GR5 ZP	8
6	1011606	BOLT-HEX: .50 X 1.25 NC GR5 ZP	2
7	1014443	WASHER-FLAT: .50 ZP	2
8	1027461	NUT-TOPLOCK: .50 NC GR5 ZP	4
9	305557	FLAIL ROD	6
10	1011623	BOLT-HEX: .63 X 2.00 NC GR5 ZP	6
11	1013024	WASHER-FLAT: .63 ZP	6
12	52355	FLAIL-SWEEP 1 X 13-1/4	12
13	52354	FLAIL-RUBBER 1 X 12	27
	52356	FLAIL-STUDED 1 X 12	
14	1011607	BOLT-HEX: .50 X 1.50 NC GR5 ZP	2
15	51549	SPACER 1"	6

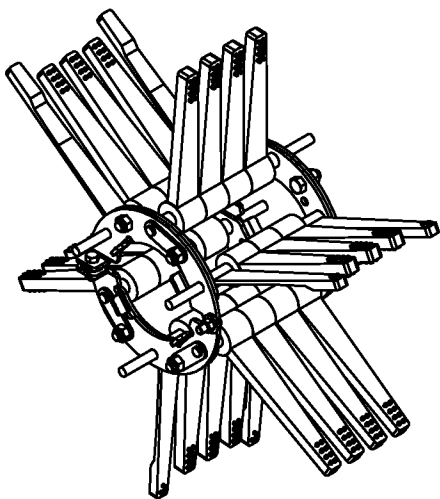
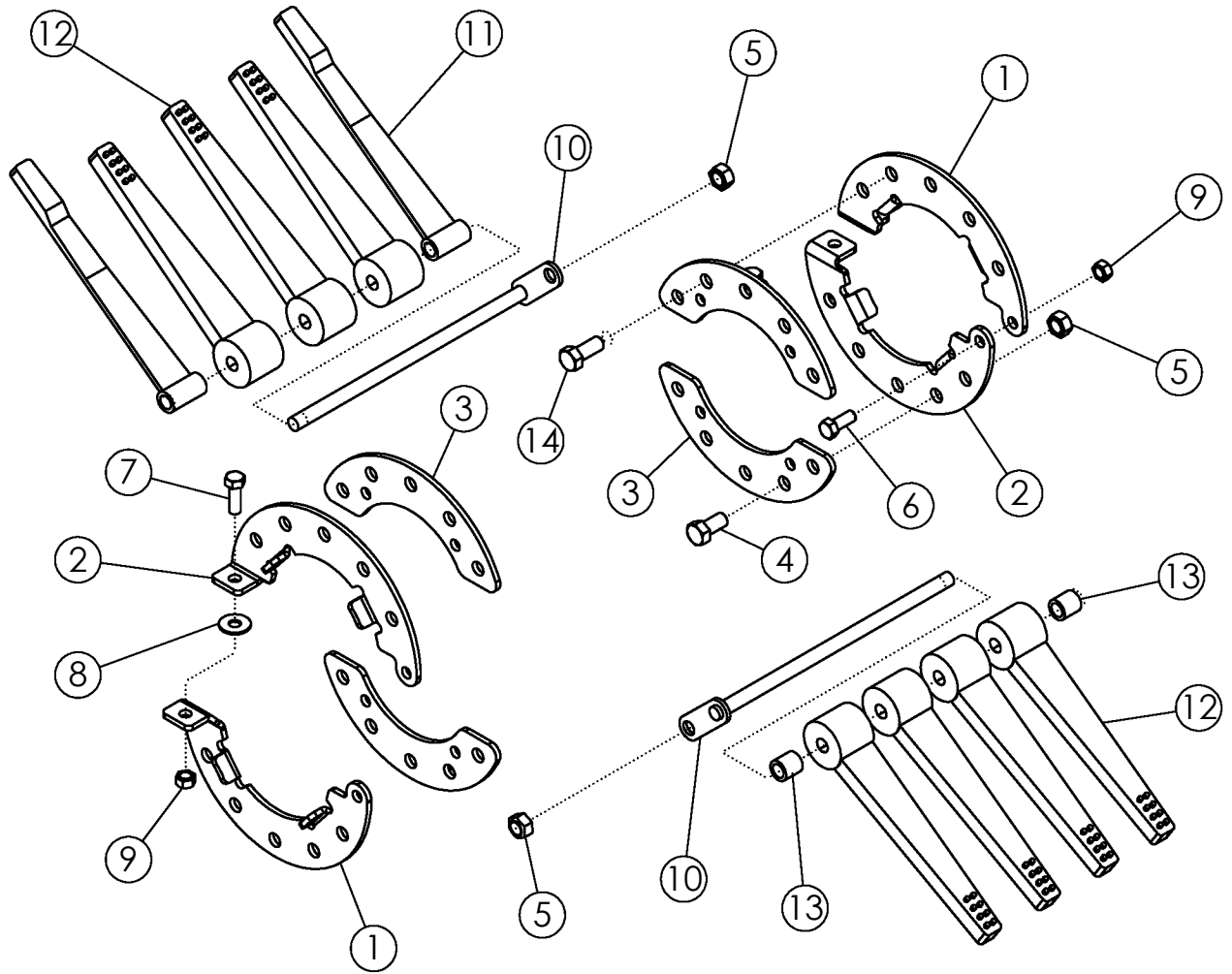

FLAILS ON #3 DRUM 22" #68920

ITEM	PART NO.	DESCRIPTION	QTY
1	52062	FLAIL RING LH - ZP	2
2	52061	FLAIL RING RH - ZP	2
3	58084	PLATE-REINFORCEMENT ZP	4
4	1032509	BOLT-HEX: .63 X 1.25 NC GR5 ZP	2
5	1016595	NUT-TOPLOCK: .63 NC GR5 ZP	8
6	1011606	BOLT-HEX: .50 X 1.25 NC GR5 ZP	2
7	1011607	BOLT-HEX: .50 X 1.50 NC GR5 ZP	2
8	1014443	WASHER-FLAT: .50 ZP	2
9	1027461	NUT-TOPLOCK: .50 NC GR5 ZP	4
10	305557	WLDMT-6 FLAIL ROD 13.875" ZP	6
11	52355	FLAIL-SWEEP 1 X 13-1/4	6
12	307259	FLAIL-RUBBER 1 X 12 TAPERED	21
13	51549	SPACER-1"	6
14	1014349	BOLT-HEX: .63 X 1.50 NC GR5 ZP	6

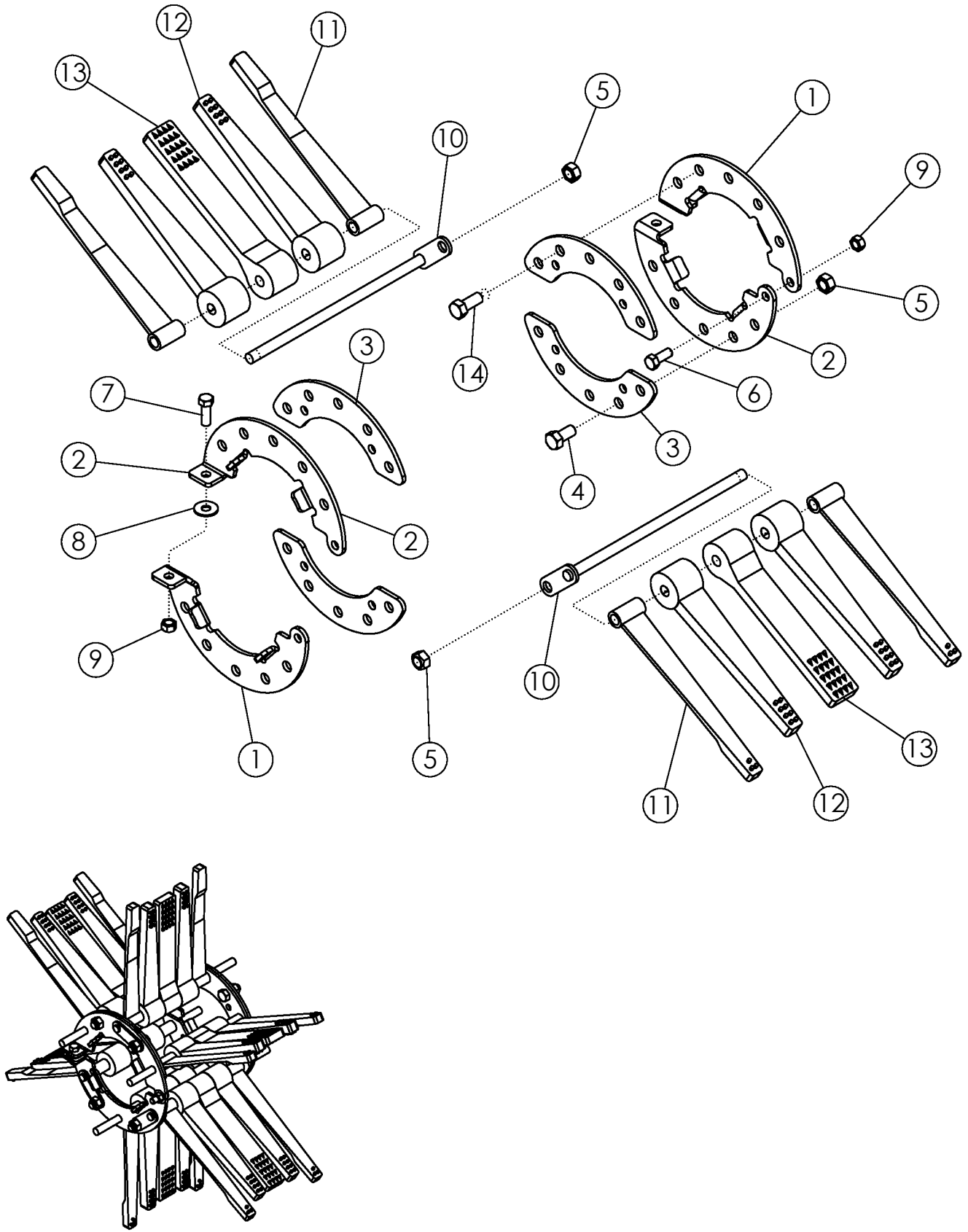

FLAILS ON #3 DRUM 22" #69413

ITEM	PART NO.	DESCRIPTION	QTY
1	52062	FLAIL RING LH - ZP	2
2	52061	FLAIL RING RH - ZP	2
3	58084	PLATE-REINFORCEMENT ZP	4
4	1032509	BOLT-HEX: .63 X 1.25 NC GR5 ZP	2
5	1016595	NUT-TOPLOCK: .63 NC GR5 ZP	8
6	1011606	BOLT-HEX: .50 X 1.25 NC GR5 ZP	2
7	1011607	BOLT-HEX: .50 X 1.50 NC GR5 ZP	2
8	1014443	WASHER-FLAT: .50 ZP	2
9	1027461	NUT-TOPLOCK: .50 NC GR5 ZP	4
10	305557	WLDMT-6 FLAIL ROD 13.875" ZP	6
11	52355	FLAIL-SWEEP 1 X 13-1/4	12
12	307259	FLAIL-RUBBER 1 X 12 TAPERED	12
13	307261	FLAIL-RUBBER 2 X 12	6
14	1014349	BOLT-HEX: .63 X 1.50 NC GR5 ZP	6

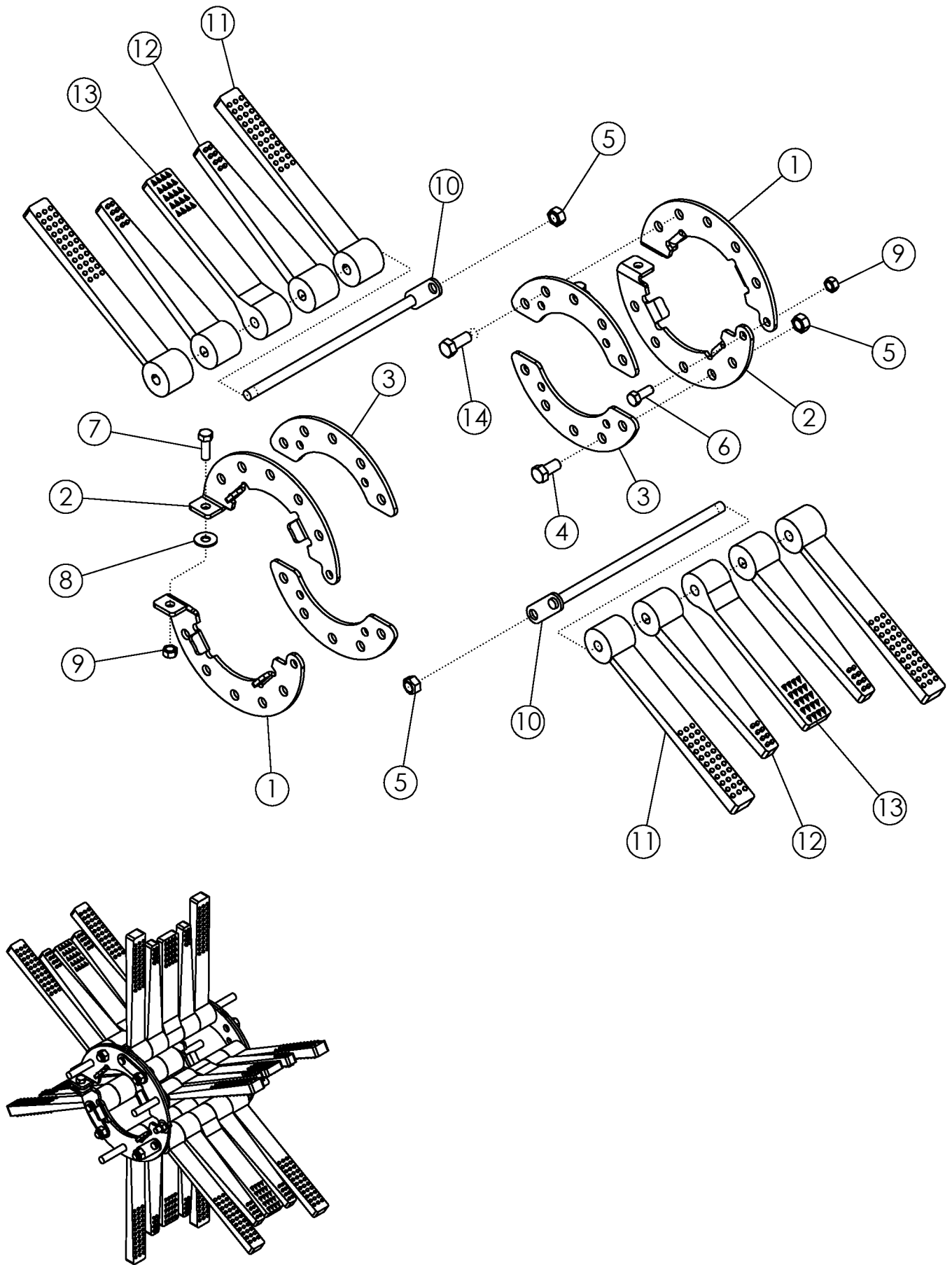

FLAILS ON #3 DRUM 22" #69555

ITEM	PART NO.	DESCRIPTION	QTY
1	52062	FLAIL RING LH - ZP	2
2	52061	FLAIL RING RH - ZP	2
3	58084	PLATE-REINFORCEMENT ZP	4
4	1032509	BOLT-HEX: .63 X 1.25 NC GR5 ZP	2
5	1016595	NUT-TOPLOCK: .63 NC GR5 ZP	8
6	1011606	BOLT-HEX: .50 X 1.25 NC GR5 ZP	2
7	1011607	BOLT-HEX: .50 X 1.50 NC GR5 ZP	2
8	1014443	WASHER-FLAT: .50 ZP	2
9	1027461	NUT-TOPLOCK: .50 NC GR5 ZP	4
10	305557	WLDMT-6 FLAIL ROD 13.875" ZP	6
11	307260	FLAIL-RUBBER 1.5 X 14" SWEEP	12
12	307259	FLAIL-RUBBER 1 X 12 TAPERED	12
13	307261	FLAIL-RUBBER 2 X 12	6
14	1014349	BOLT-HEX: .63 X 1.50 NC GR5 ZP	6

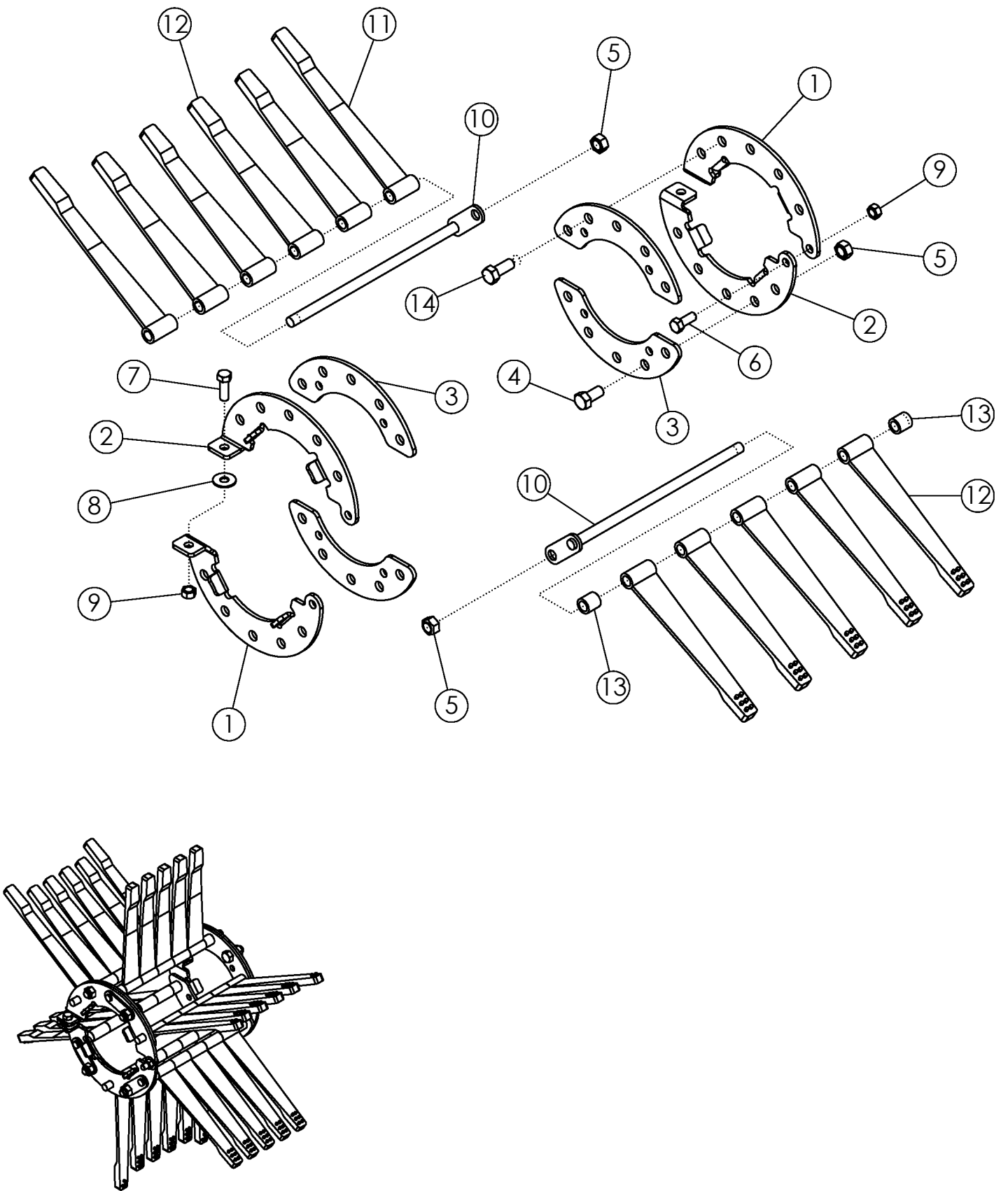

FLAILS ON #3 DRUM 30" #69853

ITEM	PART NO.	DESCRIPTION	QTY
1	52062	FLAIL RING LH - ZP	2
2	52061	FLAIL RING RH - ZP	2
3	58084	PLATE-REINFORCEMENT ZP	4
4	1032509	BOLT-HEX: .63 X 1.25 NC GR5 ZP	2
5	1016595	NUT-TOPLOCK: .63 NC GR5 ZP	8
6	1011606	BOLT-HEX: .50 X 1.25 NC GR5 ZP	2
7	1011607	BOLT-HEX: .50 X 1.50 NC GR5 ZP	2
8	1014443	WASHER-FLAT: .50 ZP	2
9	1027461	NUT-TOPLOCK: .50 NC GR5 ZP	4
10	305557	WLDMT-6 FLAIL ROD 13.875" ZP	6
11	52355	FLAIL-SWEEP 1 X 13-1/4	6
12	52356	FLAIL-STUDDDED 1 X 12	27
13	51549	SPACER-1"	6
14	1014349	BOLT-HEX: .63 X 1.50 NC GR5 ZP	6

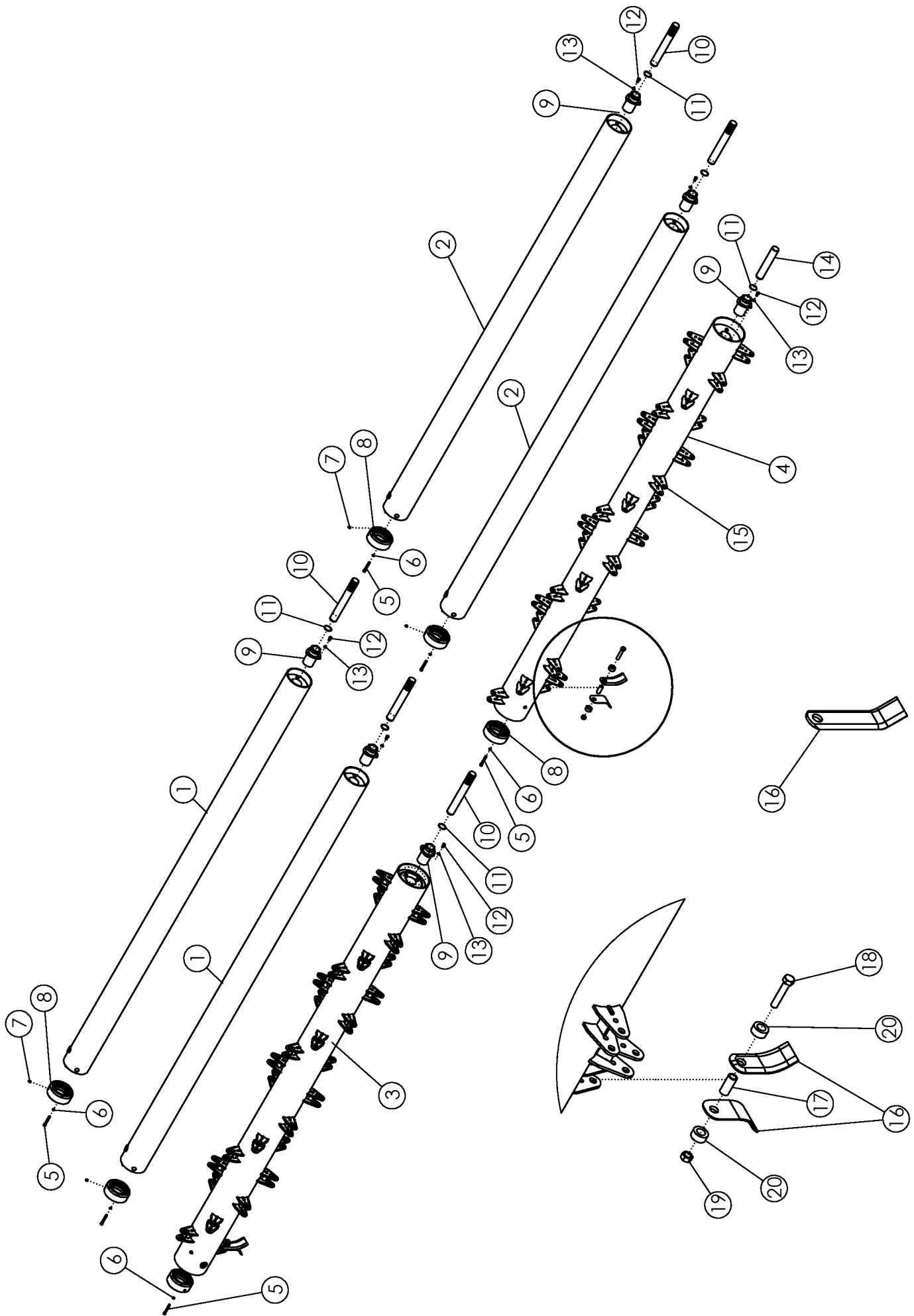

LONG STEEL FLAIL

L KNIFE FLAIL TUBE ASSEMBLY (68089)

ITEM	PART NO.	DESCRIPTION	QTY
1	68371*	FLAIL TUBE-RH 1222 TT (COMPLETE)	2
2	68375*	FLAIL TUBE-LH 1222 TT (COMPLETE)	2
3	307505	ASSY-DRUM L-FLAIL 8.5" 12R22 RH BAL	1
4	307498	ASSY-DRUM L-FLAIL 8.5" 12R22 LH BAL	1
5	68417	SCREW: S-H-CAP .38 X 2.75 NC	36
6	68418	WASHER-LOCK: .38 HIGH COLLAR	36
7	1030766	ZERK-GREASE: .13 NPT	6
8	68412	DRIVE SLEEVE	6
9	64163	TRANTORQUE: 1.750" X 3.375"	6
10	68442	SHAFT-SPLINED COUPLING	3
11	64184	RING-RETAINING 1.750"	6
12	1011599	BOLT-HEX: .38 X .75 NC GR5 ZP	18
13	1011586	WASHER-LOCK: .38 ZP	18
14	68445	SHAFT-IDLER	3
15	68400	WLDMT-FLAIL HOLDER	64
16	307236	FLAIL-STEEL 5.31" LONG	128
17	68427	BUSHING-L KNIFE	64
	305152	BUSHING-L KNIFE LONG	
18	65825	BOLT-HEX: .63 X 3.25 NC GR5 ZP	64
19	1016595	NUT-TOPLOCK: .63 NC GR5 ZP	64
20	68426	SPACER- L KNIFE	128
	305153	SPACER- L KNIFE LONG	

* QUANTITY OF 3 ON A NON-STEEL FRONT DRUM

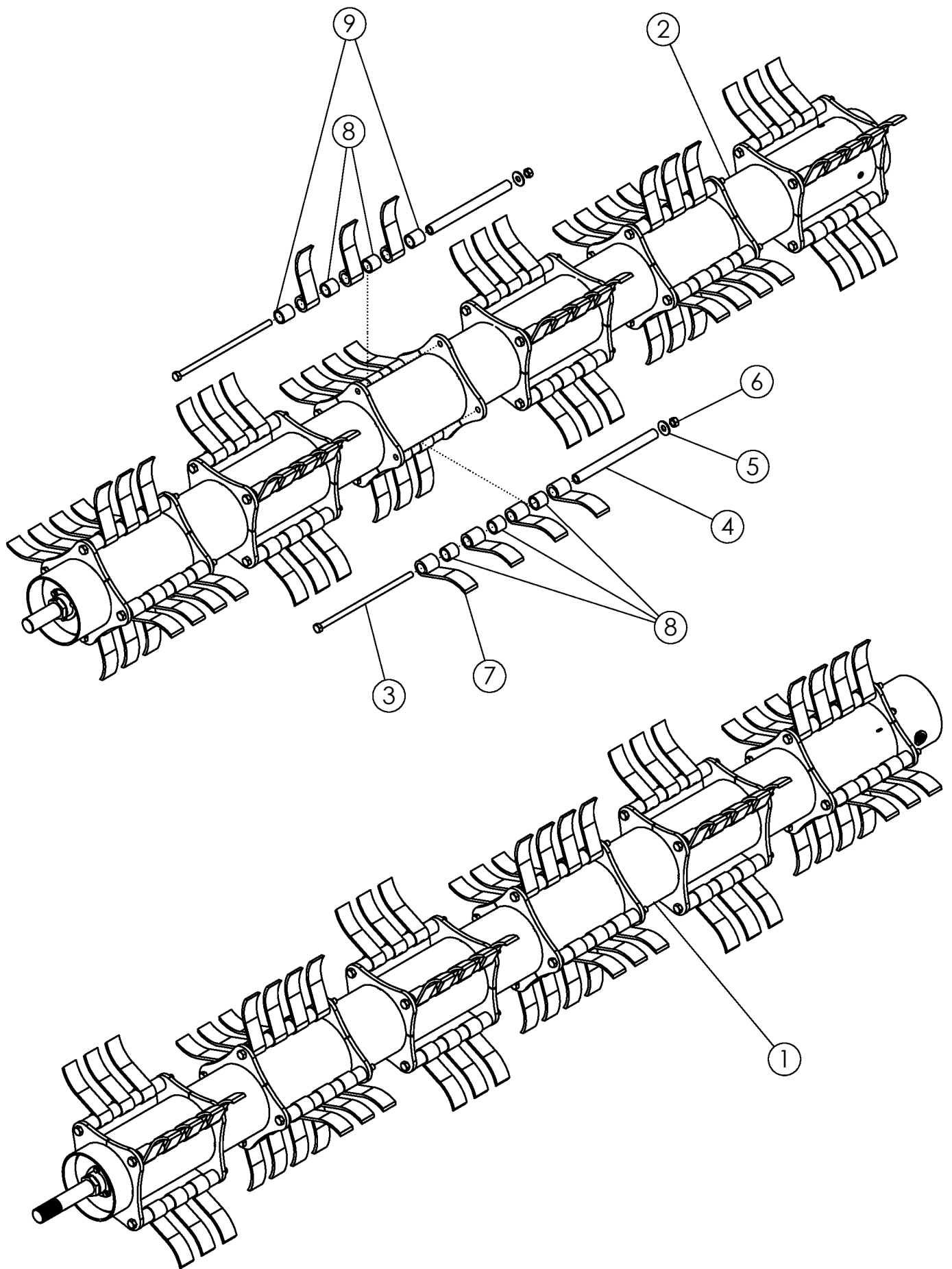

STEEL FLAIL ASSEMBLY (305184)

ITEM	PART NO.	DESCRIPTION	QTY
1	307337	ASSY-DRUM CUP 7"-1.25" EYE OVER ROW-RH 1222 BALANCED	1
2	307330	ASSY-DRUM CUP 7"-1.25" EYE OVER ROW-LH 1222 BALANCED	1
3	306766	BOLT-HEX: .63 X 14.87 NC GR8 ZP	24
4	307388	BUSHING-FLAIL 12.688" 1.13" OD HT	24
5	1013024	WASHER-FLAT: .63 ZP	24
6	1016595	NUT-TOPLOCK: .63 NC GR5 ZP	24
7	307387	FLAIL-CUP 7.0" 1.25" EYE	84
8	307390	SPACER 1.45" LARGE	60
9	307391	SPACER 1.70" LARGE	24

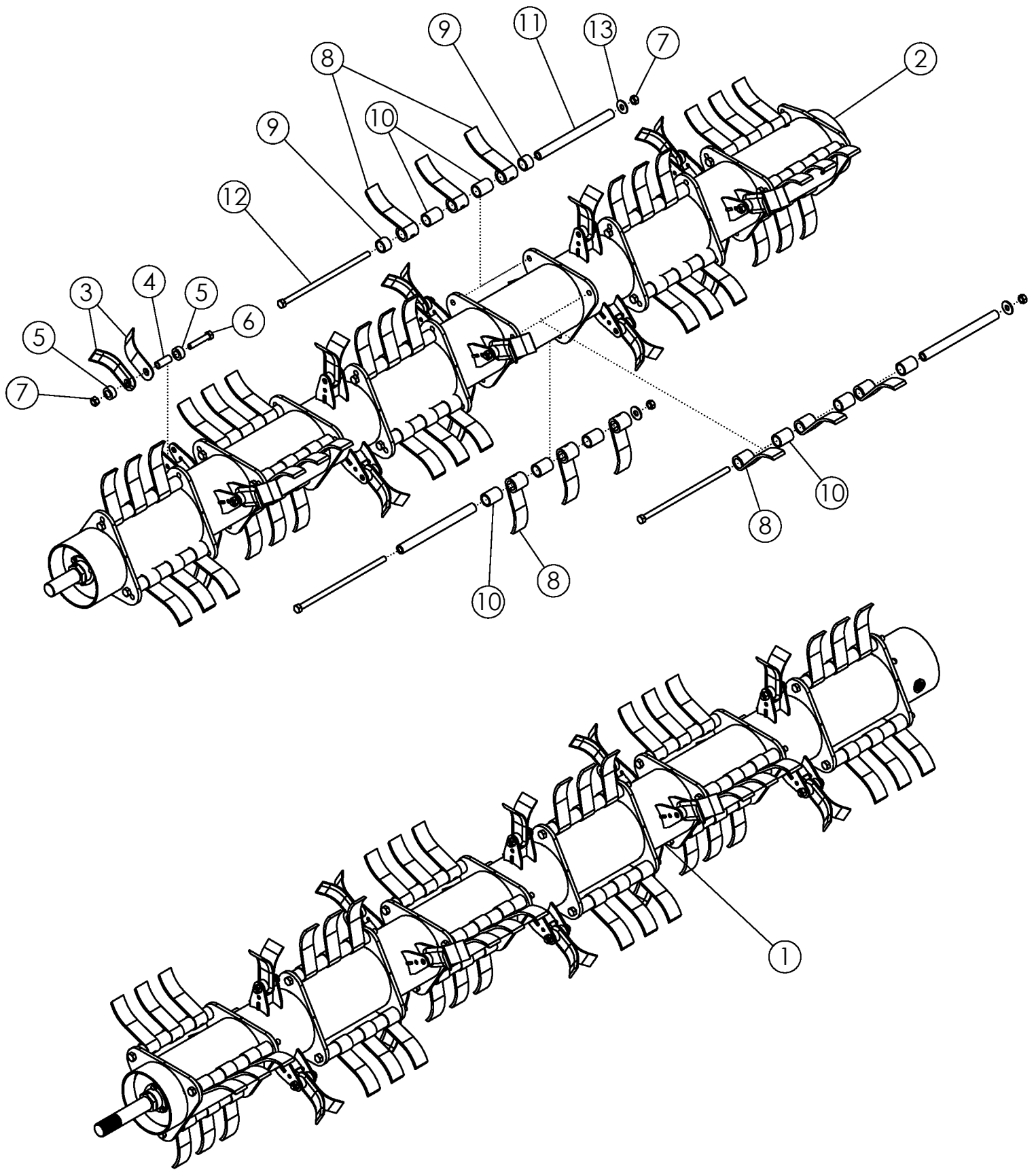

STEEL FLAIL ASSEMBLY

ITEM	PART NO.	DESCRIPTION	QTY
1	307490	ASSY-DRUM CUP W/L 8.5"-1.25"EYE 3-PIN 12R22 RH BAL	1
2	307481	ASSY-DRUM CUP W/L 8.5"-1.25"EYE 3-PIN 12R22 LH BAL	1
3	307236	FLAIL-STEEL 5.31" LONG	30
4	68427	BUSHING-L KNIFE	15
5	68426	SPACER-POLYURETHANE L KNIFE	30
6	65825	BOLT-HEX: .63 X3.25 NC GR5 ZP	15
7	1016595	NUT-TOPLOCK: .63 NC GR5 ZP	33
8	307387	FLAIL-CUP 7.0" 1.25" EYE	54
9	307456	SPACER 1.09" LARGE	48
10	307457	SPACER 2.12" LARGE	12
11	307388	BUSHING-FLAIL 12.688" 1.13" OD HT	18
12	306766	BOLT-HEX: .63 X14.87 NC GR8 ZP	18
13	1013024	WASHER-FLAT: .63 ZP	18

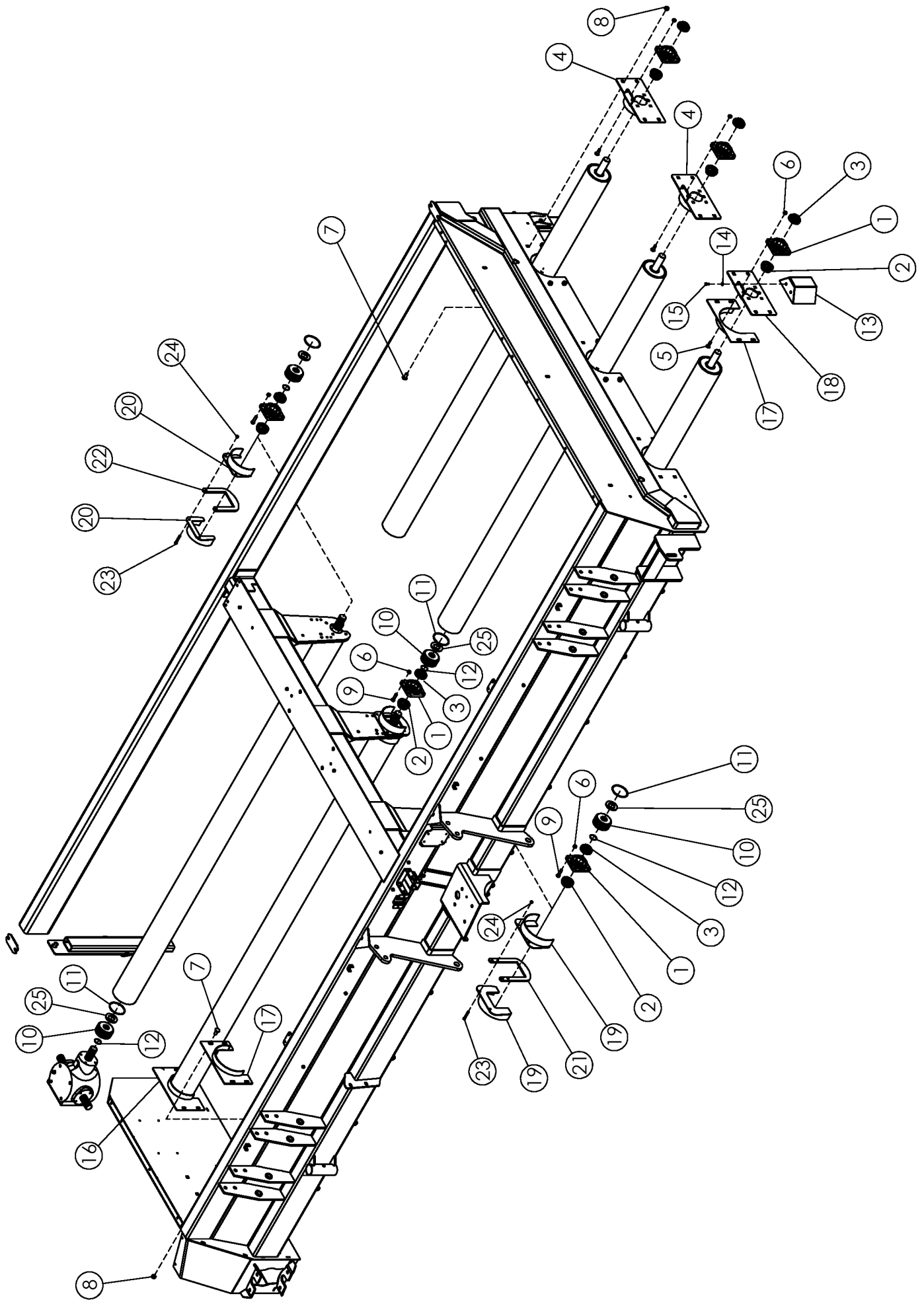

FLAIL TUBE MOUNTING

ITEM	PART NO.	DESCRIPTION	QTY
1	52404	BEARING-FLANGE 1.75	6
2	52382	SEAL PROTECTOR 1.75	6
3	52383*	LOCK PROTECTOR 1.75	6
4	68244	WLDMT-BEARING PLATE	2
5	1011660	BOLT-CRG: .50 X 1.50 NC GR5 ZP	12
6	1027461	NUT-TOPLOCK: .50 NC GR5 ZP	24
7	72063	BOLT-CRG: .63 X 1.50 NC GR5 ZP	24
8	1016595	NUT-TOPLOCK: .63 NC GR5 ZP	24
9	1011609	BOLT-HEX: .50 X 2.00 NC GR5 ZP	6
10	68413	COUPLER-DRIVE	6
11	68414	O-RING 70 BUNA	6
12	68415	SNAP RING	12
13	68462	WLDMT-IDLER SHIELD	3
14	1011586	WASHER-LOCK: .38 ZP	6
15	1011599	BOLT-HEX: .38 X .75 NC GR5 ZP	6
16	51809	WLDMT-SHIELD ANTI-WRAP	4
17	307290	WLDMT-8.5" ANTI WRAP NARROW	2
18	307296	PLATE-DRUM BEARING MOUNT RED	1
19	307293	WLDMT-8.5" ANTI WRAP WIDE	2
20	305465	WLDMT-ANTI WRAP	4
21	307315	PLATE-DRUM FAILURE CATCH 2.0	1
22	306985	PLATE-DRUM CATCH	2
23	1015174	BOLT-HEX: .38 X 2.50 NC GR5 ZP	6
24	1016999	NUT-TOPLOCK: .38 NC GR5 ZP	6
25	306388	RUBBER-FLAIL TUBE SPACER	6

* Replaces lock collar provided with bearing for the center

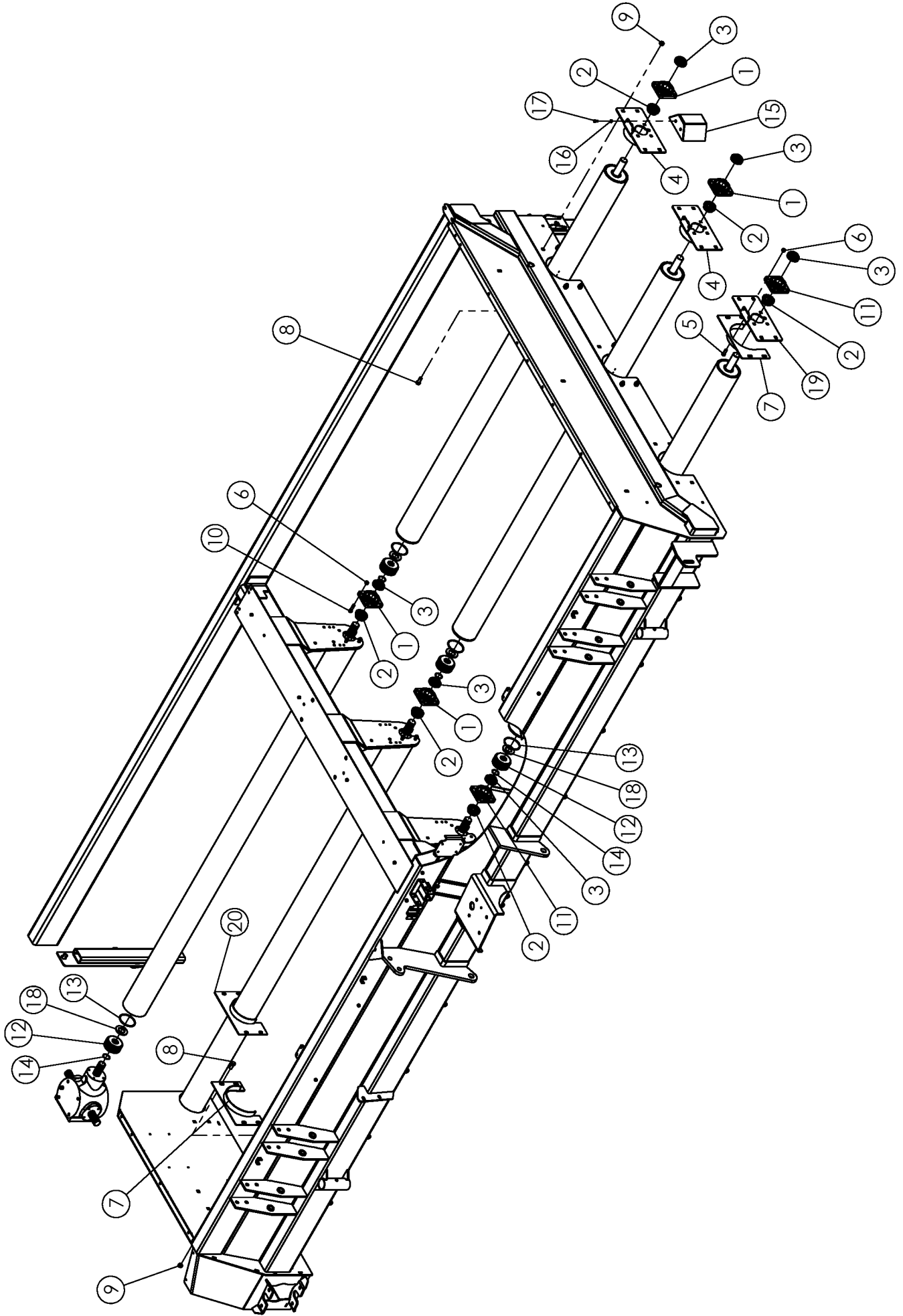

FLAIL TUBE MOUNTING - STEEL FRONT DRUM OPTION

ITEM	PART NO.	DESCRIPTION	QTY
1	52404	BEARING-FLANGE 1.75	4
2	52382	SEAL PROTECTOR 1.75	6
3	52383*	LOCK PROTECTOR 1.75	6
4	68244	WLDMT-BEARING PLATE	2
5	1011660	BOLT-CRG: .50 X 1.50 NC GR5 ZP	12
6	1027461	NUT-TOPLOCK: .50 NC GR5 ZP	24
7	307290	WLDMT-8.5" ANTI WRAP NARROW	2
8	72063	BOLT-CRG: .63 X 1.50 NC GR5 ZP	24
9	1016595	NUT-TOPLOCK: .63 NC GR5 ZP	24
10	1011609	BOLT-HEX: .50 X 2.00 NC GR5 ZP	12
11	306999	ASSY-BEARING-FLANGE 1-3/4" N-SEAL (STEEL)	2
12	68413	COUPLER-DRIVE	6
13	68414	O-RING 70 BUNA	6
14	68415	SNAP RING	6
15	68462	WLDMT-IDLER SHIELD	3
16	1011586	WASHER-LOCK: .38	6
17	1011599	BOLT-HEX: .38 X .75 NC GR5 ZP	6
18	306388	RUBBER-FLAIL TUBE SPACER	6
19	307296	PLATE-DRUM BEARING MOUNT RED	1
20	51809	WLDMT-SHEILD ANTI-WRAP	2

* Replaces lock collar provided with bearing for the center

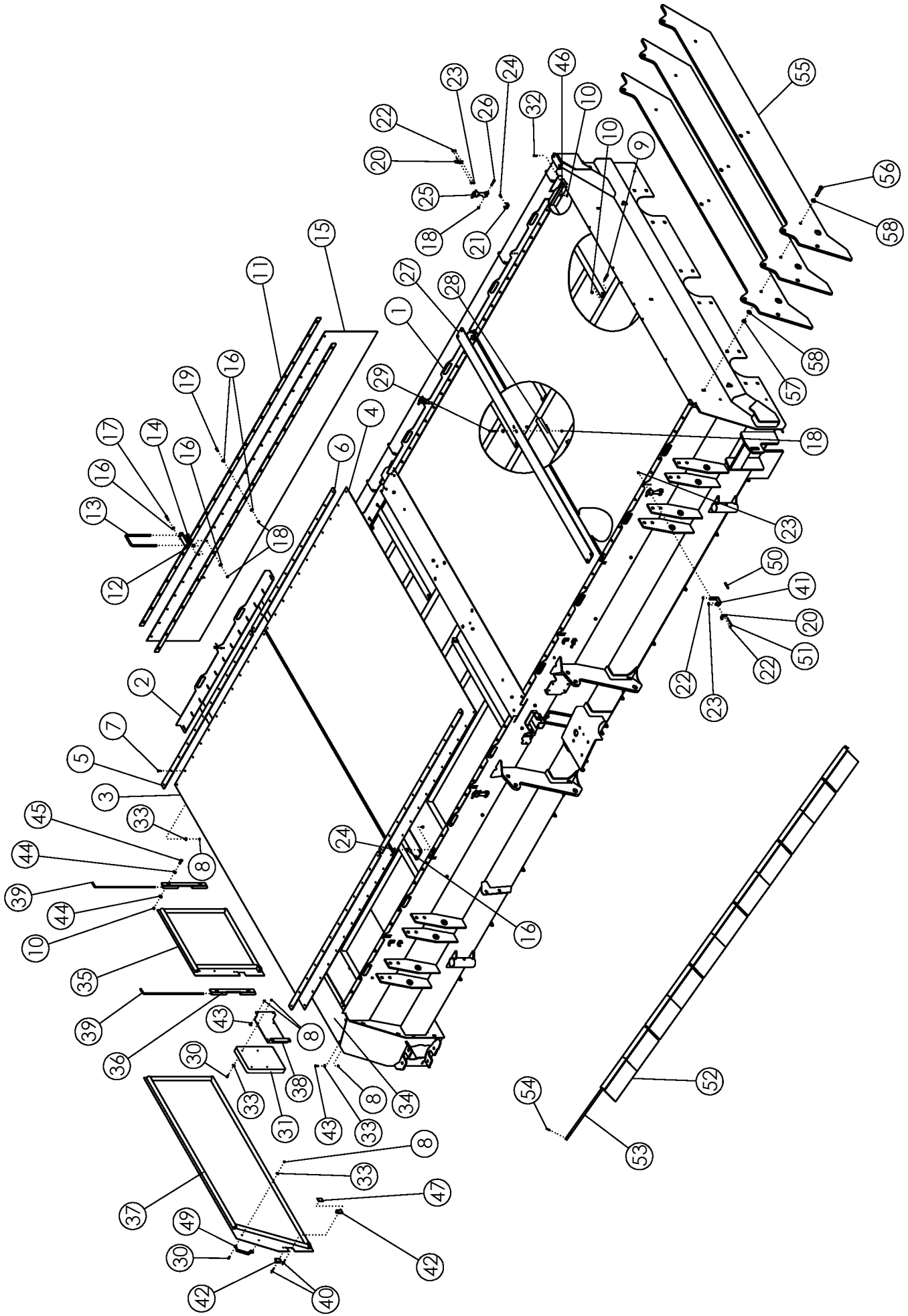

DOORS AND SHIELDS

ITEM	PART NO.	DESCRIPTION	QTY
1	62509	WLDMT-DOOR	4
2	62499	WLDMT-DOOR	4
3	62504	TARP	2
4	62505	TARP	2
5	59815	BRACKET-BOLTING	4
6	62191	BRACKET-BOLTING	4
7	1013423	BOLT-HEX: .25 X 1.00 NC GR5 ZP	92
8	1030946	NUT-TOPLOCK: .25 NC GR5 ZP	117
9	1011725	BOLT-HEX: .38 X 2.00 NC GR5 ZP	16
10	1016999	NUT-TOPLOCK: .38 NC GR5 ZP	28
11	63446	BAR-REAR FLAP 0622, 1222	4
12	63448	WLDMT-REAR FLAP MOUNT	8
13	63458	U-BOLT: .50 X 9.25 X 4.00 X 9.25 ZP	8
14	1027461	NUT-TOPLOCK: .50 NC GR5 ZP	16
15	52357	FLAP-REAR	2
16	1011583	WASHER-FLAT: .31 ZP	100
17	1013424	BOLT-HEX: .31 X 1.75 NC GR5 ZP	8
18	1030700	NUT-TOPLOCK: .31 NC GR5 ZP	70
19	1011598	BOLT-HEX: .31 X 1.00 NC GR5 ZP	38
20	52239	HOOD BRACKET-LARGE	8
21	52237	ANCHOR BRACKET-LARGE	4
22	1013462	SCREW-R-H-SL: .19 X .50 NC GR2	24
23	1026591	NUT-K-LOCK: .19 NC GR2 ZP	24
24	1011597	BOLT-HEX: .31 X .75 NC GR5 ZP	12
25	52238	RUBBER HOOK LARGE	8
26	1011285	BOLT-HEX: .31 X 2.00 NC GR5 ZP	8
27	68245	PLATE-SPLICE	2
28	62182	PLATE-BOLTING	2
29	1016132	BOLT-HEX: .31 X 2.25 NC GR5 ZP	4
30	1011595	BOLT-HEX: .25 X .75 NC GR5 ZP	8
31	64635	CASE-MANUAL STORAGE	1
32	1016362	BOLT-CRG: .38 X 1.25 NC GR5 ZP	8
33	1020416	WASHER-FLAT: .25 ZP	106
34	68201	PANEL-TOP SHIELD	1
35	68386	WLDMT-REAR SIDE DOOR	1
36	72680	WLDMT-DOOR HINGE	2
37	68387	WLDMT-FRONT SIDE DOOR	1
38	68324	PLATE-DEF MANUAL CASE	1
39	51303	DOOR HINGE ROD ZP	2
40	1011974	RIVET-POP: .19 X .531 ZP	4

CONTINUED

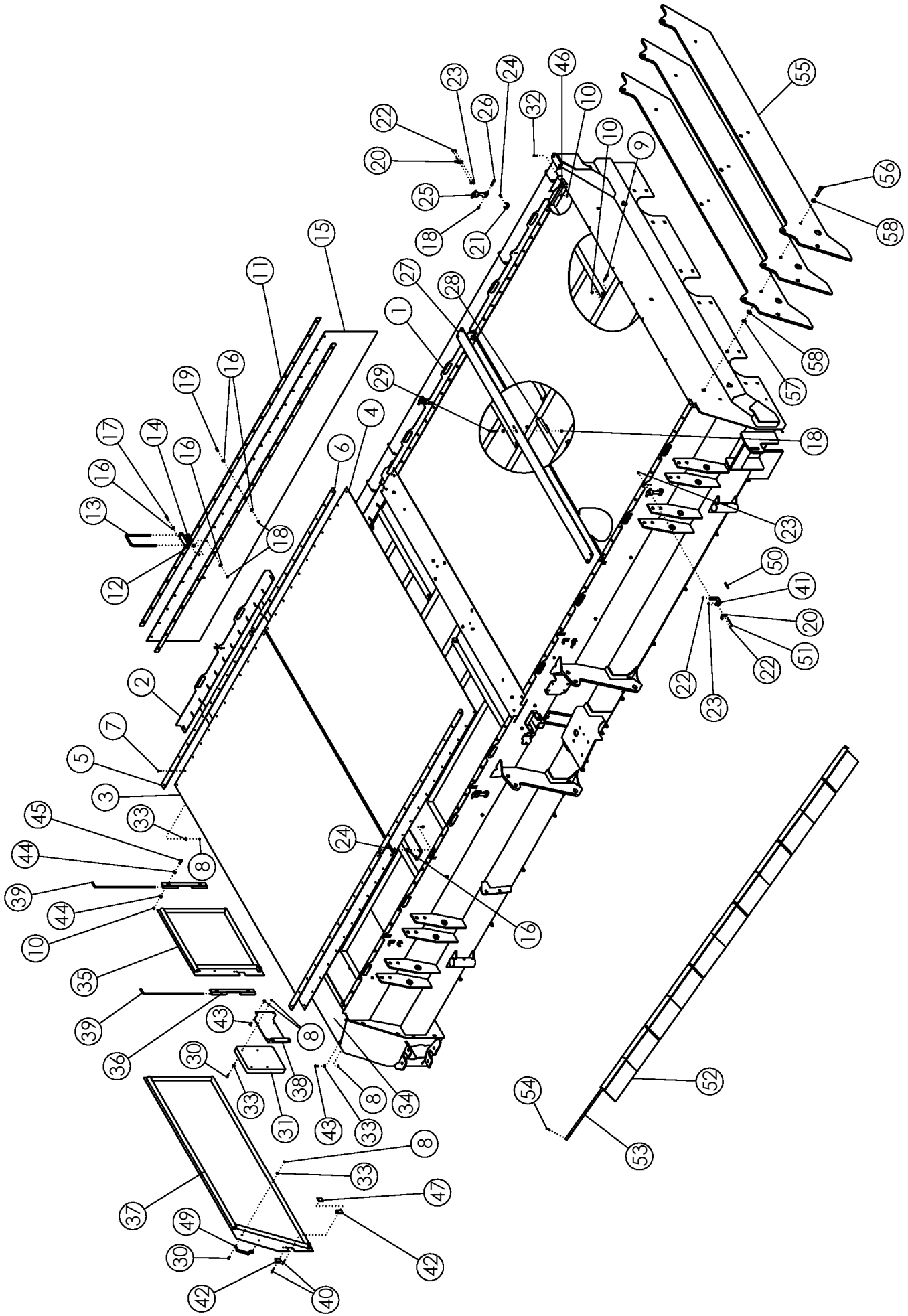

DOORS AND SHIELDS (CONTINUED)

ITEM	PART NO.	DESCRIPTION	QTY
41	68320	TARP BRACKET	4
42	69140	WLDMT-DOOR LATCH	4
43	68602	BOLT-CRG: .25 X .75 NC GR5 ZP	17
44	1011828	WASHER-FLAT: .38 ZP	16
45	1011601	BOLT-HEX: .38 X 1.25 NC GR5 ZP	4
46	68992	PLATE-DOOR CROSS LH 12R	1
	68993	PLATE-DOOR CROSS RH 12R (NOT SHOWN)	1
47	69141	PLATE-DOOR LATCH SPACER	2
48	51304	DOOR LOCK ZP	2
49	68715	HANDLE-GRAB DOOR	2
50	305392	TUBE-TARP BRACKET STIFFENER ZP	8
51	305393	SCREW-F-H-S-C: 10-24 X 3.50 NC	8
52	64648	FLAP-RUBBER	22
53	64695	SHAFT-RETAINING SHIELD 6R/12R	2
54	1012375	PIN-COTTER: .19 X 1.50 ZP	4
55	306353	PLATE-WEIGHT 12R DEF	3
56	65825	BOLT-HEX: .63 X 3.25 NC GR5 ZP	3
57	1016595	NUT-TOPLOCK: .63 NC GR5 ZP	3
58	1013004	WASHER-FLAT: SAE .63 ZP	6

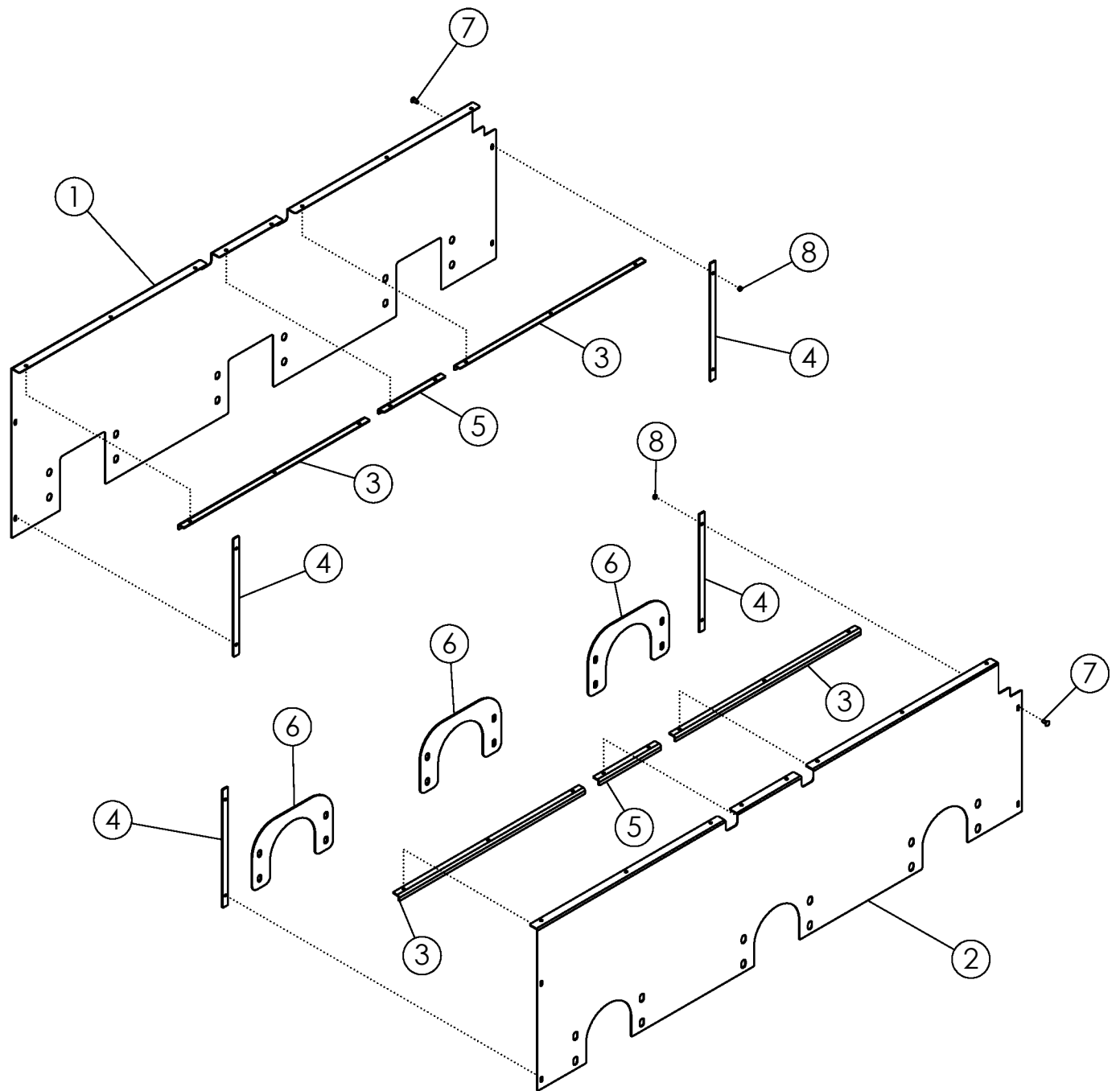

SIDE LINER KIT

ITEM	PART NO.	DESCRIPTION	QTY
1	69964	LINER-RH DEF PLASTIC	1
2	69965	LINER-LH DEF PLASTIC	1
3	69966	PLATE-RETAINER FRT/BACK	4
4	69968	PLATE-RETAINER VERT	4
5	69967	PLATE-RETAINER MID	2
6	69969	PLATE-LH LOWER RETAINER	3
7	59488	BOLT-CRG: .38 X 1.00 NC GR5 ZP	24
8	1016999	NUT-TOPLOCK: .38 NC GR5 ZP	24

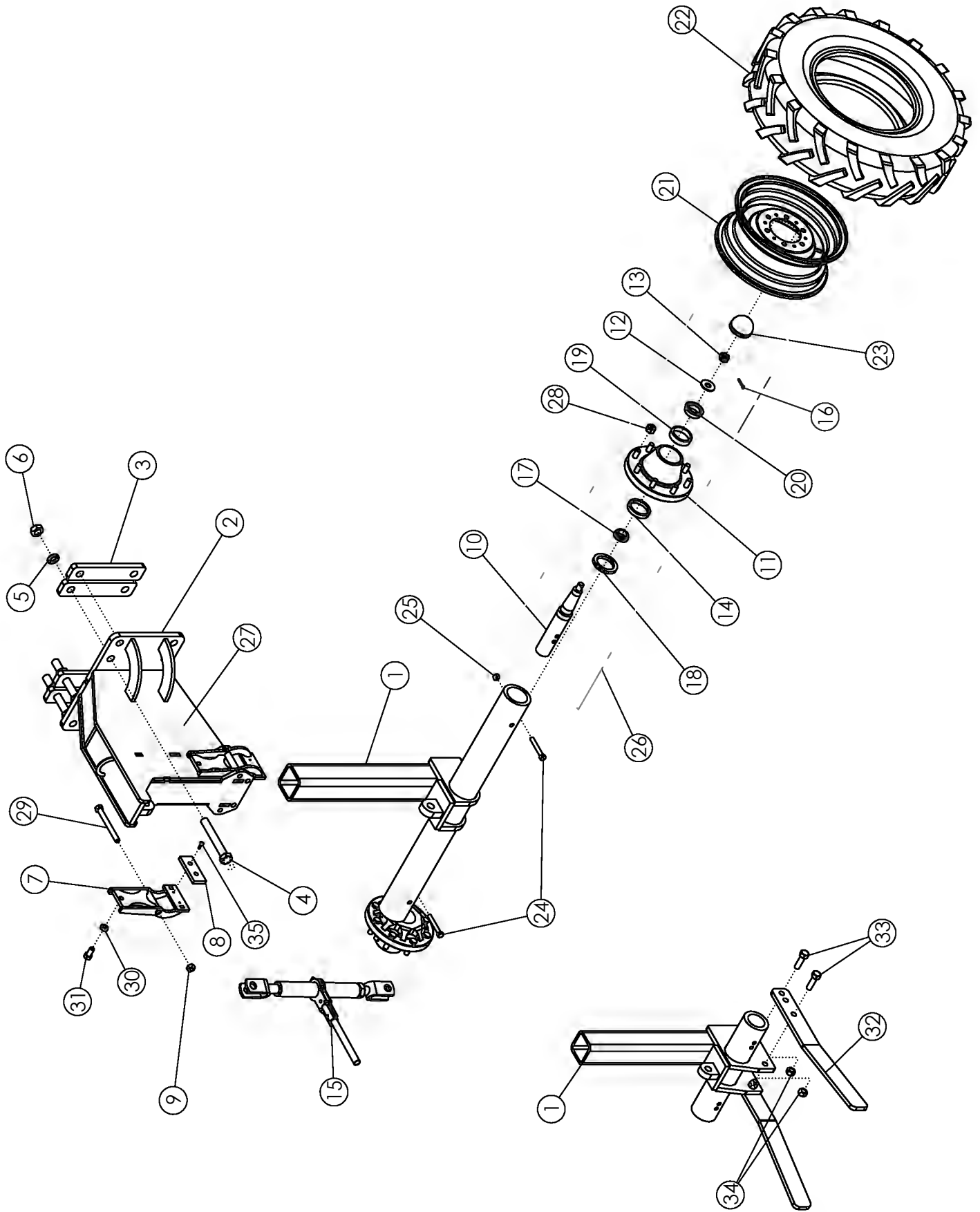

STANDARD REAR STRUTS - 11.2 X 24 TIRES

ITEM	PART NO.	DESCRIPTION	QTY
1	68331	WLDMT-SPINDLE HOUSING (44")	1
	68236	WLDMT-SPINDLE HOUSING (NARROW)	1
	68766	WLDMT-SPINDLE HOUSING- 6" OFFSET RH	1
	68767	WLDMT-SPINDLE HOUSING- 6" OFFSET LH	1
	69434	ASSY-OSC SPINDLE HOUSING (44")	1
2	68332	WLDMT-STD STRUT UPPER	1
3	58408	BAR - BOLTING	4
4	1018839	BOLT-HEX: 1.00 X 7.00 NC GR8 ZP	8
5	1013539	WASHER-LOCK: 1.00 ZP	8
6	1012664	NUT-HEX: 1.00 NC GR2 ZP	8
7	69956	WLDMT- DEF STRUT CLAMP	2
8	69971	PLASTIC-STRUT CLAMP	2
9	1016595	NUT-TOPLOCK: .63 NC GR5 ZP	2
10	52954*	SPINDLE	2
11	53623*	HUB-WHEEL 8-BOLT	2
12	1030728*	WASHER-FLAT: .SAE 1.000 ZP	2
13	1030726*	NUT-SPINDLE: 1.00 NF	2
14	53622*	BEARING CUP INNER	2
15	52407	RATCHET JACK-PAINTED	1
16	1030797*	PIN-COTTER: .19 X 1.75 NP	2
17	53621*	BEARING CONE INNER	2
18	53619*	SEAL	2
19	52243*	BEARING CUP OUTER	2
20	53620*	BEARING CONE OUTER	2
21	56903	WHEEL W10 X 24 8 BOLT	2
22	56976	TIRE 11.2-24 10 PLY R1	2
	68973	TUBE-REPAIR 11.2-24 (NOT SHOWN)	AR
23	53624*	CAP-HUB	2
24	1011618	BOLT-HEX: .50 X 5.00 NC GR5 ZP	2
25	1027461	NUT-TOPLOCK: .50 NC GR5 ZP	2
26	53167	ASSY HUB & SPINDLE	2
27	52248	DECAL-CAUTION	1
28	53625*	NUT-WHEEL: .63-18NF	16
29	1013068	BOLT-HEX .63 X 6.00 NC GR5 ZP	2
30	66336	NUT-JAM: .63 NF GR2 ZP	2
31	1030703	BOLT-HEX: .63 X 1.25 NF GR5 ZP	2
32	305640	PLATE-SCRAPER 11.2-24 DEF	2
33	1016598	BOLT- .75 X 2.50 NC GR5 ZP	4
34	1017000	NUT-TOPLOCK: .75 NC GR5 ZP	4
35	69987	SCREW-MACH: FH-TORX .25-20 X 1.00	4

* Items are included in Item 26

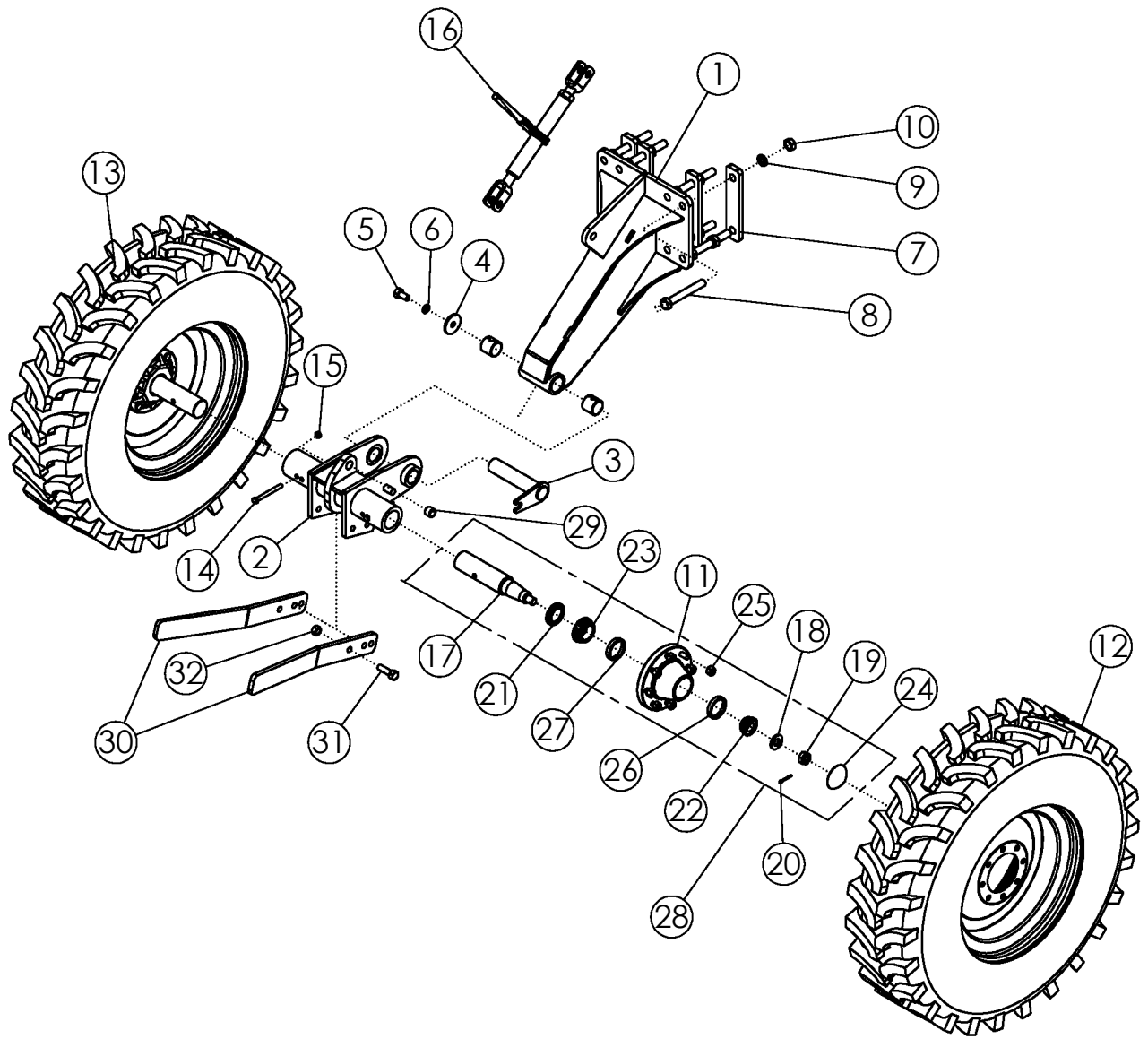

ASSY-STRUT STANDARD 11.2-24 PIVOT

ITEM	PART NO.	DESCRIPTION	QTY
1	306019	ASSY-STRUT STANDARD PIVOT	1
	1011748	ZERK - GREASE	1
	73466	BUSHING-SPRING 2.25 X 2.0 X 2.0 L	2
2	305561	WLDMT-SPINDLE RECEIVER 22"	1
	305562	WLDMT-SPINDLE RECIEVER 44" (NOT SHOWN)	
	306704	WLDMT-SPIDLE RECIEVER 36" (NOT SHOWN)	
3	305573	WLDMT-DEF STRUT FLAG PIN	1
4	305575	PLATE-PIVOT POINT END CAP ZP	1
5	58367	BOLT-HEX: .75 X 1.50 NC GR5 ZP	1
6	1012061	WASHER-LOCK: .75 ZP	1
7	58408	BAR - BOLTING	4
8	1018839	BOLT-HEX: 1.0 x 7.00 NC GR8 ZP	8
9	1013539	WASHER-LOCK: 1.00 ZP	8
10	1012664	NUT-HEX: 1.00 NC GR2 ZP	8
11	53623*	HUB-WHEEL 8-BOLT	2
12	56986	HRVRH WHEEL	1
13	63992	HRVLH WHEEL	1
14	1011618	BOLT-HEX: .50 X 5.00 NC GR5 ZP	2
15	1027461	NUT-TOPLOCK: .50 NC GR5 ZP	2
16	52407	RATCHET JACK-PAINTED	1
17	52954*	SPINDLE-STANDARD	2
18	1030728*	WASHER-FLAT: SAE 1.00 ZP GR8	2
19	1030726*	NUT-SPINDLE: 1.00 NF NP	2
20	1030797*	PIN-COTTER: .19 X 1.75 NP	2
21	53619*	SEAL	1
22	53620*	BEARING-CONE	1
23	53621*	CONE-BEARING	1
24	53624*	HUB CAP	1
25	53625*	NUT-WHEEL .625-18NF	8
26	53622**	BEARING-CUP INNER	1
27	52243**	BEARING-CUP OUTER	1
28	53167	ASSY-HUB & SPINDLE: 8-BOLT W/ZERK	2
29	45572	SPRING BUSHING 1.25 X 1 X 1	1
30	305640	PLATE-SCRAPER 11.2-24 DEF	4
31	1016598	BOLT-HEX: .75 X 2.50 NC GR5 ZP	8
32	1017000	NUT-TOPLOCK: .75 NC GR5 ZP	8

* INCLUDED IN ITEM 28

**INCLUDED IN ITEM 11

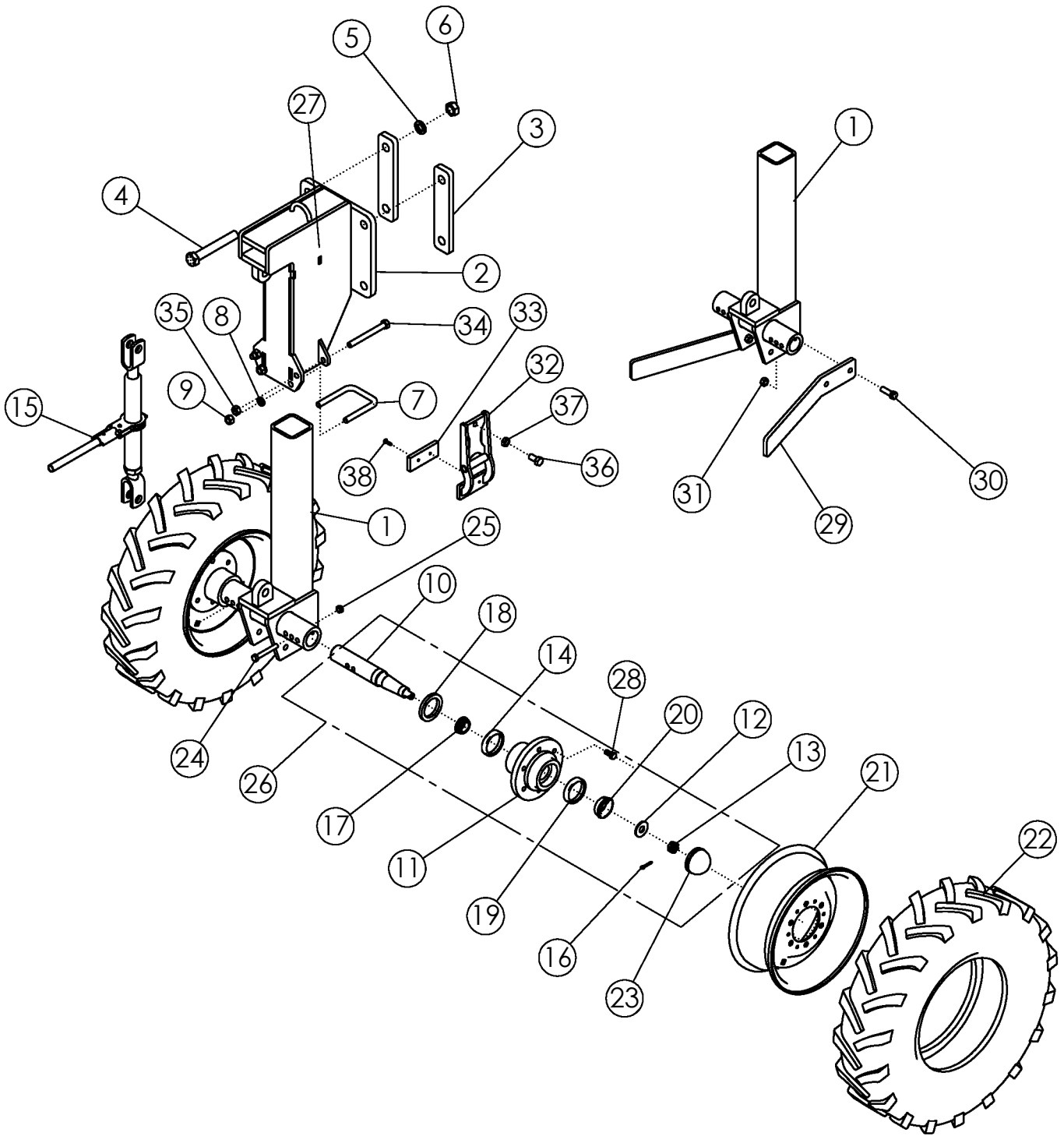

STANDARD REAR STRUTS - 7.60 X 15 TIRES

ITEM	PART NO.	DESCRIPTION	QTY
1	58281	WLDMT-SPINDLE HOUSING	1
	64402	WLDMT-SPINDLE HOUSING- 6" OFFSET RH	1
	64406	WLDMT-SPINDLE HOUSING- 6" OFFSET LH	1
2	63559	WLDMT-STD STRUT UPPER	1
3	58408	BAR - BOLTING	2
4	1018839	BOLT-HEX: 1.00 X 7.00 NC GR8 ZP	4
5	1013539	WASHER-LOCK: 1.00 ZP	4
6	1012664	NUT-HEX: 1.00 NC GR2 ZP	4
7	60547	U-BOLT: .63 X 5.25 X 4.00 X 5.25	1
8	1011813	WASHER-LOCK: .63 ZP	2
9	1011578	NUT-HEX: .63 NC GR2 ZP	2
10	52138*	SPINDLE	2
11	52247*	HUB-WHEEL 6-BOLT	2
12	1012377*	WASHER-SPINDLE: .81 X 2.00 NP	2
13	1012376*	NUT-SLOTTED: .75 NF GR5 NP	2
14	52243*	CUP-BEARING INNER	2
15	52407	RATCHET JACK-PAINTED	1
16	35128	PIN-COTTER: .19 X 1.50 NP	2
17	52245*	CONE-BEARING INNER	2
18	52242*	SEAL	2
19	52244*	CUP-BEARING OUTER	2
20	52246*	CONE-BEARING OUTER	2
21	52411	WHEEL 6.00-15 6 BOLT	2
22	52410	TIRE 7.60-15 I-3 6 PLY	2
	68974	TUBE-REPAIR 7.60-15 (NOT SHOWN)	AR
23	52241*	CAP-HUB	2
24	1011612	BOLT-HEX: .50 X 3.50 NC GR5 ZP	2
25	1027461	NUT-TOPLOCK: .50 NC GR5 ZP	2
26	52116	ASSY HUB & SPINDLE	2
27	52248	DECAL-CAUTION	1
28	1013426*	BOLT-LUG: .50 X 1.00 NF GR5 ZP	12
29	305642	PLATE-SCRAPER 7.6-15 DEF	2
30	1011623	BOLT-HEX: .63 X 2.00 NC GR5 ZP	4
31	1016595	NUT-TOPLOCK: .63 NC GR5 ZP	4
32	69956	WLDMT- DEF STRUT CLAMP	2
33	69971	PLASTIC-STRUT CLAMP	2
34	1013068	BOLT-HEX: .63 X 6.00 NC GR5 ZP	2
35	1016595	NUT-TOPLOCK: .63 NC GR5 ZP	2
36	1030703	BOLT-HEX: .63 X 1.25 NF GR5 ZP	2
37	66336	NUT-JAM: .63 NF GR2 ZP	2
38	69987	SCREW-MACH: FH-TORX .25-20 X 1.00	4

* Items are included in Item 26

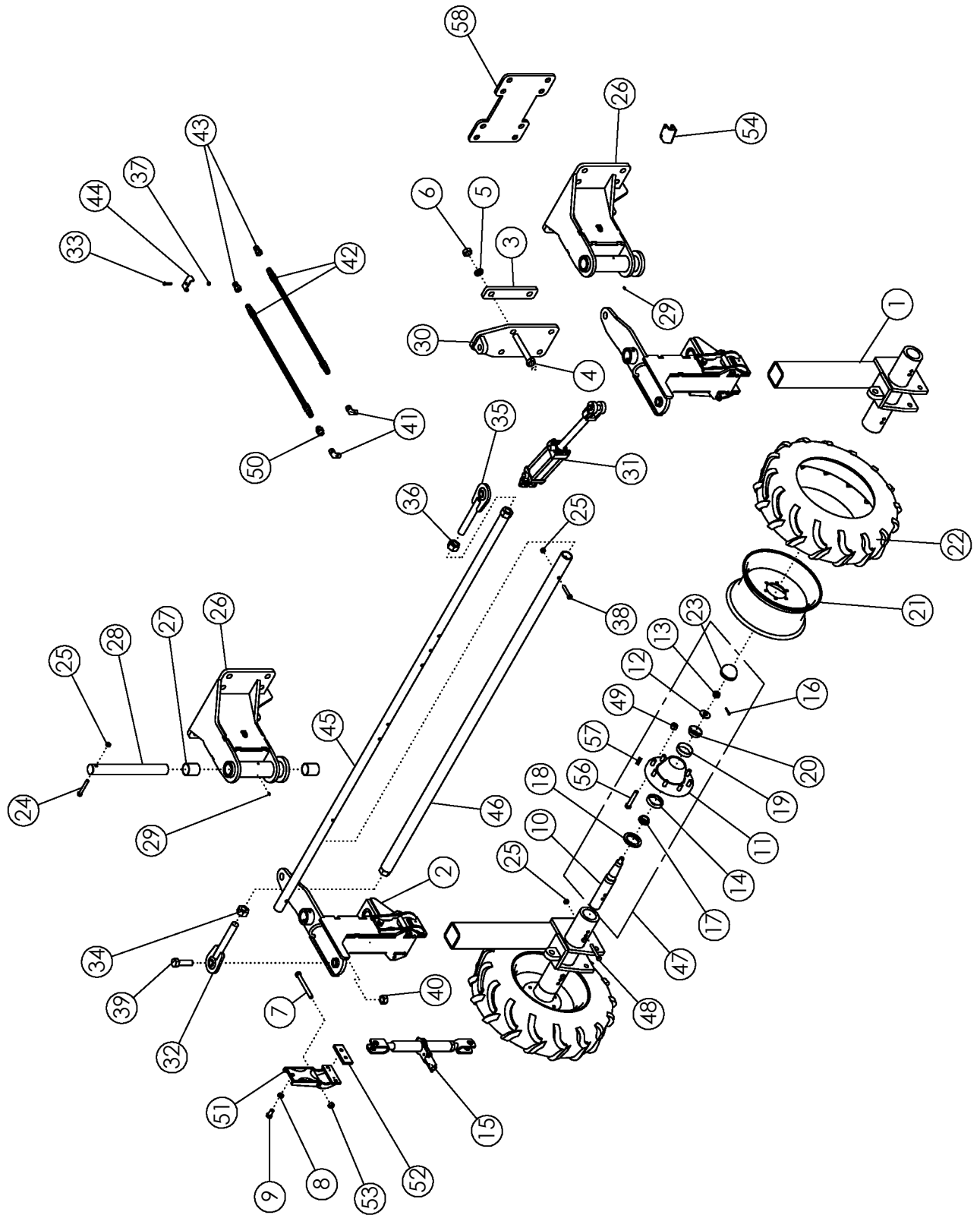

STEERABLE REAR STRUTS - 11.2 X 24 TIRES			
ITEM	PART NO.	DESCRIPTION	QTY
1	68236	WLDMT-SPINDLE HOUSING	2
2	68237	WLDMT-STEERABLE STRUT UPPER	2
3	58408	BAR-BOLTING	10
4	1018839	BOLT-HEX: 1.00 X 7.00 NC GR8 ZP	20
5	1013539	WASHER-LOCK: 1.00 ZP	20
6	1012664	NUT-HEX: 1.00 NC GR2 ZP	20
7	1013068	BOLT-HEX: .63 X 6.00 NC GR5 ZP	2
8	66336	PIN-CYLINDER	2
9	1030703	BOLT-HEX: .63 X 1.25 NF GR5 ZP	2
10	52954*	1022707 SPINDLE-STANDARD	4
11	53623*	HUB-WHEEL 8 BOLT	4
12	1030728*	WASHER-FLAT: SAE 1.00 ZP GR8	4
13	1030726*	NUT-SPINDLE: 1.00 NF NP	4
14	53622*	7446-42 BEARING CUP-INNER	2
15	52407	RATCHET JACK , PAINTED	2
16	1030797*	PIN-COTTER: .19 X 1.75 NP	4
17	53621*	7445-52 BEARING CONE-INNER	4
18	53619*	7044-116 SEAL	4
19	52243*	7446-28 BEARING CUP-OUTER	4
20	53620*	7445-35 BEARING CONE-OUTER	4
21	56903	WHEEL W10 X24 8 BOLT (1.875 POS)	4
22	56976	TIRE 11.2-24 10 PLY R1	4
	68973	TUBE-REPAIR 11.2-24	AR
23	53624*	1D88691 CAP-HUB	4
24	1011612	BOLT-HEX: .50 X 3.50 NC GR5 ZP	2
25	1027461	NUT-TOPLOCK: .50 NC GR5 ZP	7
26	305925	ASSY-PIVOT MOUNT	2
27	59204	BUSHING-BORED 2.500 X 2.015	4
28	58274	SHAFT	2
29	1011748	ZERK-GREASE: .25 UNF STRAIGHT	4
30	68234	WLDMT-CYLINDER BRACKET	1
31	62319	CYLINDER-HYDRAULIC 2 X 4" 3000	1
	69654	SEAL KT-CYL 2 X 4 3000PSI #62319	
32	58203	WLDMT-TIE ROD END LH	1
33	1014124	BOLT-HEX: .31 X 1.50 NC GR5 ZP	2
34	1030729	NUT-HEX: 1.25 NC GR2 ZP LH	1
35	58186	WLDMT-TIE ROD END RH	1
36	1011621	NUT-HEX: 1.25 NC GR2 ZP RH	1
37	1030700	NUT-TOPLOCK: .31 NC GR5 ZP	2
38	1016858	BOLT-HEX: .50 X 2.75 NC GR5 ZP	1
39	1011626	BOLT-HEX: 1.00 X 3.50 NC GR5 ZP	2

CONTINUED

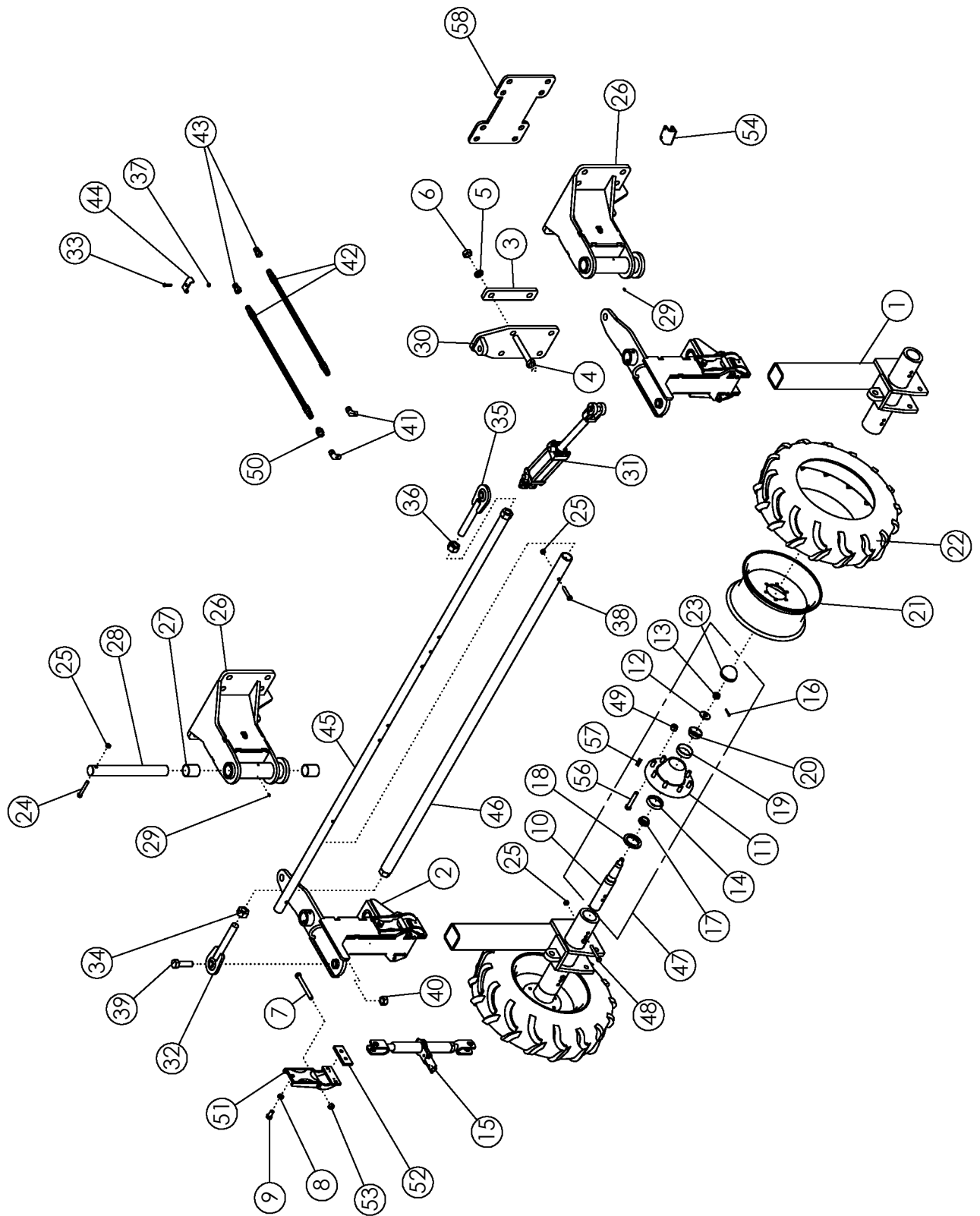

STEERABLE REAR STRUTS - 11.2 X 24 TIRES (CONTINUED)

ITEM	PART NO.	DESCRIPTION	QTY
40	1016969	NUT-TOPLOCK: 1.00 NC GR5 ZP	2
41	1026247	FTG-ELBOW: 6MP-8MJ 90	2
42	300032	HOSE: .50 X 276 8MB-8FJX	2
43	36290	PIONEER TIP 8010-15P (#8 ORB)	2
44	50714	CLAMP 1/2" ZP	2
45	306581	WLDMT-TIE ROD MALE 107"	1
46	306577	WLDMT-TIE ROD FEMALE 85"	1
47	53167	ASSY-HUB & SPINDLE	4
48	1011618	BOLT-HEX: .50 X 5.00 NCGR5 ZP	4
49	53625*	NUT-WHEEL: .63-18NF	32
50	300030	FTG-RESTRICTOR 8MJ-8FJX .062	1
51	69956	WLDMT- DEF STRUT CLAMP	2
52	69971	PLASTIC-STRUT CLAMP	2
53	1016595	NUT-TOPLOCK: .63 NC GR5 ZP	2
55	69987	SCREW-MACH: FH-TORX 1/4-20 X 1.00	4
56	54393	STUD-HUB BOLT	8
57	301490	SELF TAPPING GREASE FITTING	1
WIDE (44")			
1	68331	WLDMT-SPINDLE HOUSING (44")	2
31	58890	CYLINDER-HYDRAULIC 3 X 8	1
54	68769	WLDMT-3" CYLINDER STOP	1
58	306100	PLATE-STRUT SPACER	2

* Items are included in Item 47

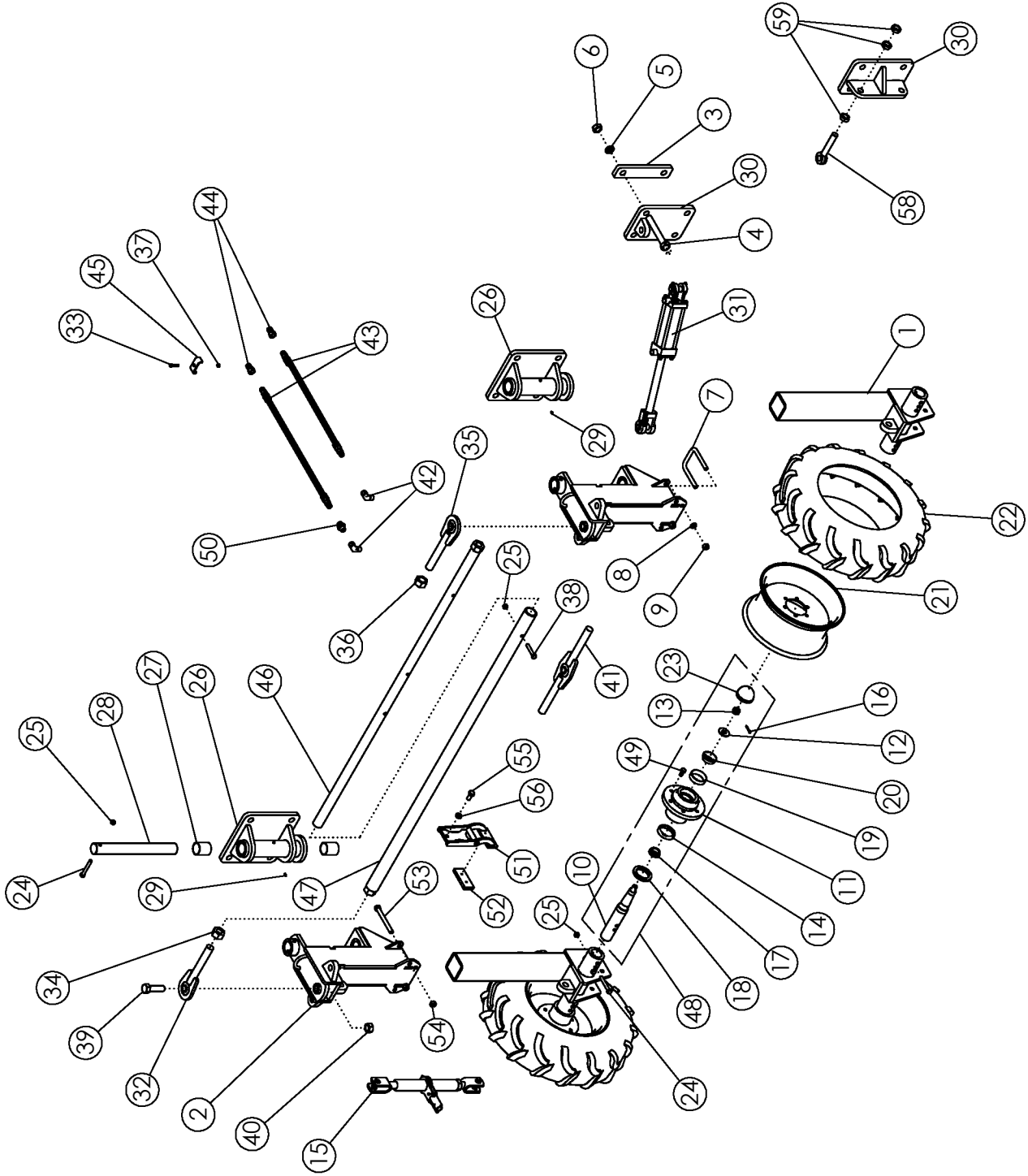

STEERABLE REAR STRUTS - 7.60 X 15 TIRES

ITEM	PART NO.	DESCRIPTION	QTY
1	58281	WLDMT-SPINDLE HOUSING	4
2	63558	WLDMT-STEERABLE STRUT UPPER	4
3	58408	BAR - BOLTING	10
4	1018839	BOLT-HEX: 1.00 X 7.00 NC GR8 ZP	20
5	1013539	WASHER-LOCK: 1.00 ZP	20
6	1012664	NUT-HEX: 1.00 NC GR2 ZP	20
7	60547	U-BOLT: .63 X 5.25 X 4.00 X 5.25	4
8	1011813	WASHER-LOCK: .63 ZP	8
9	1011578	NUT-HEX: .63 NC GR2 ZP	8
10	52138*	SPINDLE	8
11	52247*	HUB-WHEEL 6 BOLT	8
12	1012377*	WASHER-SPINDLE: .81 X 2.00 NP	8
13	1012376*	NUT-SLOTTED: .75 NF GR5 NP	8
14	52243*	BEARING CUP-INNER	8
15	52407	RATCHET JACK-PAINTED	4
16	1012375*	PIN-COTTER: .19 X 1.50 NP	8
17	52245*	BEARING CONE-INNER	8
18	52242*	SEAL	8
19	52244*	BEARING-CUP OUTER	8
20	52246*	BEARING-CONE OUTER	8
21	52411	WHEEL 6.00-15 6 BOLT	8
22	52410	TIRE 7.60-15 I-3 6 PLY	8
	68974	TUBE-REPAIR 7.60-15 (NOT SHOWN)	AR
23	52241*	CAP-HUB	8
24	1011612	BOLT-HEX: .50 X 3.50 GR5 ZP	12
25	1027461	NUT-TOPLOCK: .50 NC GR5 ZP	15
26	58283	WLDMT-PIVOT MOUNT	4
27	59204	BUSHING - BORED	8
28	58274	SHAFT	4
29	1011748	ZERK - GREASE	8
30	58410	WLDMT-CYLINDER BRACKET	1
	306727	WLDMT-ADJ CYL BRACKET 7.6 TIRES	
31	62319	CYLINDER HYDRAULIC 2 X 4	1
	69654	SEAL KIT FOR 62319	
32	58203	WLDMT-TIE ROD END LH	1
33	1014124	BOLT-HEX: .31 X 1.50 NC GR5 ZP	2
34	1030729	NUT-HEX: 1.25 NC GR2 LH ZP	3
35	58186	WLDMT-TIE ROD END RH	1
36	1011621	NUT-HEX: 1.25 NC GR2 ZP	3
37	1030700	NUT-TOPLOCK: .31 NC GR5 ZP	2

CONTINUED

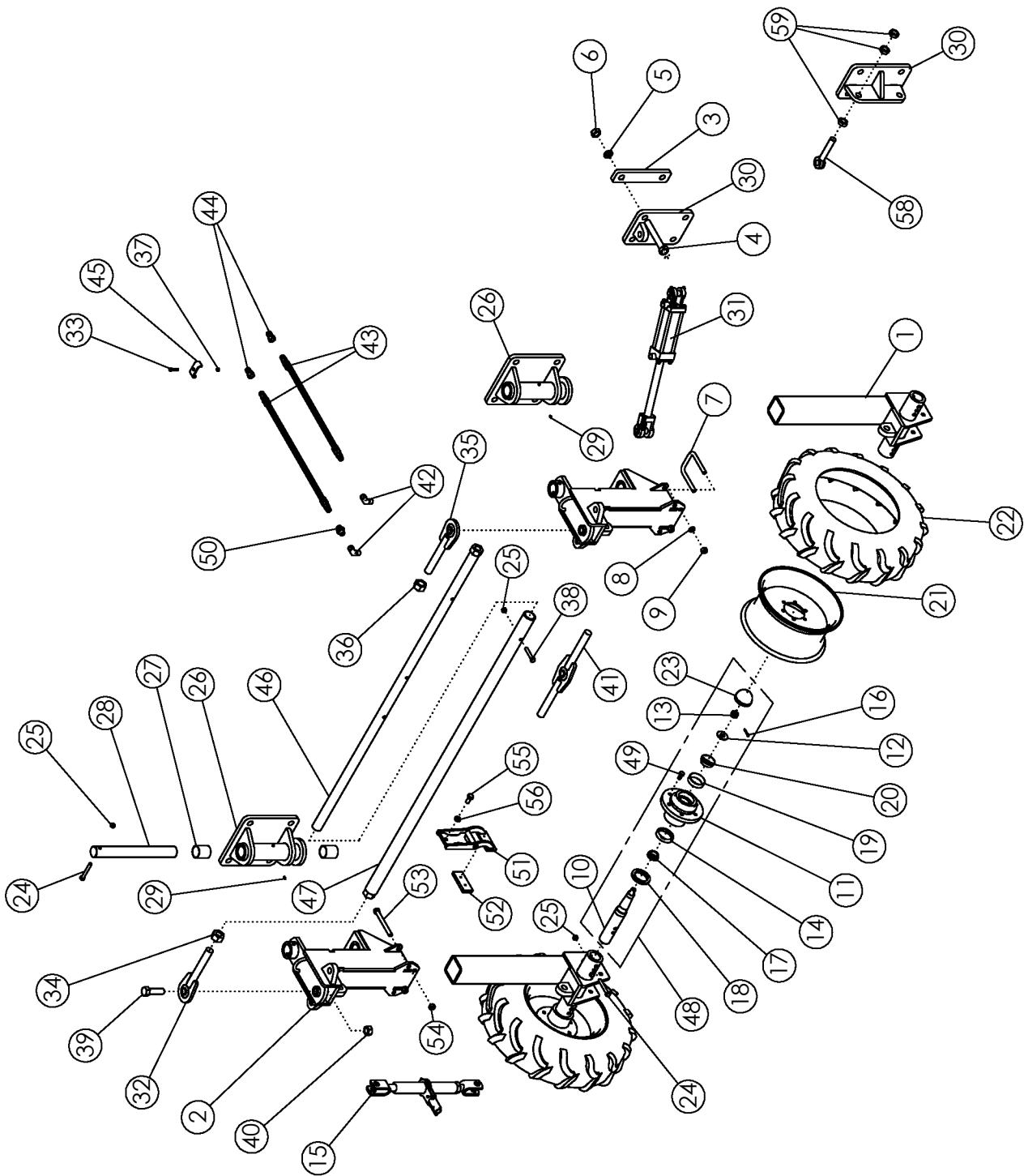

STEERABLE REAR STRUTS - 7.60 X 15 TIRES (CONTINUED)

ITEM	PART NO.	DESCRIPTION	QTY
38	1016858	BOLT-HEX: .50 X 2.75 NC GR5 ZP	3
39	1011626	BOLT-HEX: 1.00 X 3.50 NC GR5 ZP	4
40	1016969	NUT-TOPLOCK: 1.00 NC GR5 ZP	4
41	58205	WLDMT-TIE ROD END DOUBLE	2
42	1026247	FTG-ELBOW: 6MP-8MJ90	2
43	300032	HOSE: .50 X 336 8MB-8FJX	2
44	36290	PIONEER TIP 8010-15P (#8 ORB)	2
45	50714	CLAMP 1/2" ZP	2
46	58418	WLDMT-TIE ROD MALE 40"	3
47	58417	WLDMT-TIE ROD FEMALE 40"	3
48	52116	ASSY-HUB & SPINDLE	8
49	1013426*	BOLT-LUG: .50 X 1.00 NF GR5 ZP	24
50	300030	FTG-RESTRICTOR 8MJ-8FJ .062	1
51	69956	WLDMT- DEF STRUT CLAMP	4
52	69971	PLASTIC-STRUT CLAMP	4
53	1013068	BOLT-HEX: .63 X 6.00 NC GR5 ZP	4
54	1016595	NUT-TOPLOCK: .63 NC GR5 ZP	4
55	1030703	BOLT-HEX: .63 X 1.25 NF GR5 ZP	4
56	66336	NUT-JAM: .63 NF GR2 ZP	4
57	69987	SCREW-MACH: .25-20 X 1.00 (NOT SHOWN)	8
58	62081	BOLT-EYEBOLT: 1.00 X 6.00 ZP GR8	1
59	1026880	NUT-JAM: 1.00 NC GR2 ZP	3

* Items are included in Item 48

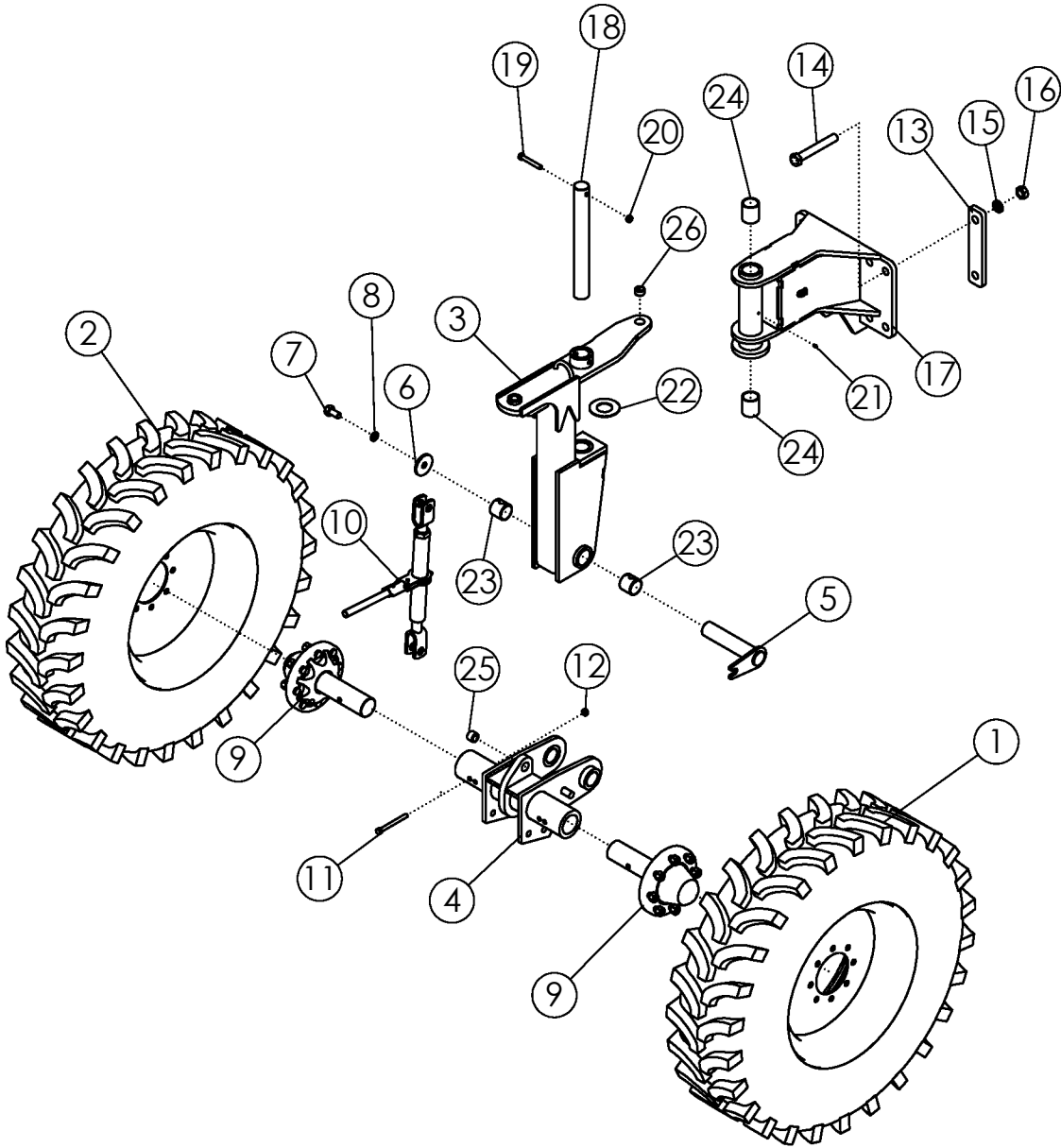

ASSY-STEERABLE STRUT UPPER

ITEM	PART NO.	DESCRIPTION	QTY
1	56986	TIRE-MNTD: 11.2-24 10PLY R1 RH	1
2	63992	TIRE-MNTD: 11.2-24 10PLY R1 LE	1
3	305560*	WLDMT-STRUT UPPER	1
4	305561	WLDMT-SPINDLE RECEIVER 22"	1
	305562	WLDMT-SPINDLE RECEIVER 44"	
5	305573	WLDMT-DEF STRUT FLAG PIN	1
6	305575	PLATE-PIVOT POINT END CAP ZP	1
7	58367	BOLT-HEX: .75 X 1.50 NC GR5 ZP	1
8	1012061	WASHER-LOCK: .75 ZP	1
9	53167	ASSY-HUB & SPINDLE: 8 BOLT W/ZERK	2
10	52407	RATCHET JACK-PAINTED	1
11	1011618	BOLT-HEX: .50 X 5.00 NC GR5 ZP	1
12	1027461	NUT-TOPLOCK: .50 NC GR5 ZP	1
13	58408	BAR - BOLTING	4
14	1018839	BOLT-HEX: 1.0 X 7.00 NC GR8 ZP	4
15	1013539	WASHER-LOCK: 1.00 ZP	4
16	1012664	NUT-HEX: 1.00 NC GR2 ZP	4
17	305925-1*	ASSY-PIVOT MOUNT	1
18	58274*	SHAFT	1
19	1011612*	BOLT-HEX: .50 X 3.50 GR5 ZP	1
20	1027461*	NUT-TOPLOCK: .50 NC GR5 ZP	1
21	1011748*	ZERK - GREASE	2
22	305586*	BUSHING-THRUST 2.062 X 4.00 X .125	1
23	73466*	BUSHING-SPRING 2.25 X 2.0 X 2.0 L (REF)	2
24	59204*	BUSHING-BORE 2.5 X 2.015	2
25	45572	SPRING BUSHING 1.25 X 1 X 1	1
26	307240*	BUSHING-SPRING 1.25 X 1.0 X 0.75	1

Parts marked by * are included in 305924

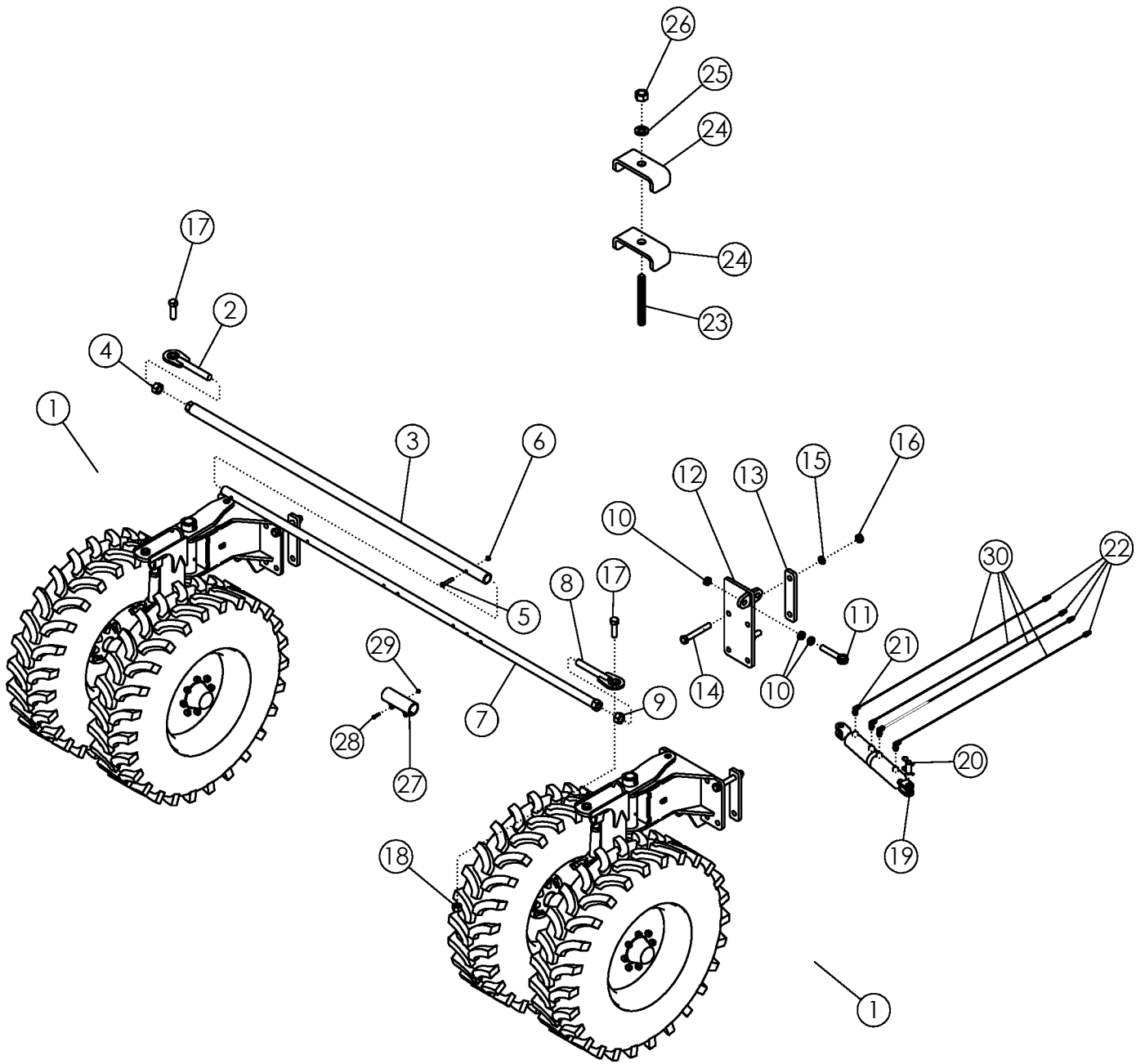

STRUTS-STEERABLE 11.2 X 24 22" CENTERING

ITEM	PART NO.	DESCRIPTION	QTY
1	305922	ASSY-STURT STEERABLE 11.2 X 24 22" PIVOT	2
2	58203	WLDMT-TIE ROD END LH	1
3	58416	WLDMT-TIE ROD 70" FEMALE	1
	306577	WLDMT-TIE ROD 85" FEMALE	
4	1030729	NUT-HEX: 1.25 NC GR2 LH ZP	1
5	1016858	BOLT-HEX: .50 X 2.75 NC GR5 ZP	1
6	1027461	NUT-TOPLOCK: .50 NC GR5 ZP	1
7	58415	WLDMT-TIE ROD 70" MALE 6 ROW	1
	306581	WLDMT-TIE ROD 107" MALE 8R/12ROW	
8	58186	WLDMT-TIE ROD END RH	1
9	1011621	NUT-HEX: 1.25 NC GR2 ZP	1
10	1026880	NUT-HEX JAM: 1.00 NC GR2 ZP	3
11	62081	BOLT-EYEBOLT 1" X 6" GR 8	1
12	306732	WLDMT-CYLINDER BRACKET ADJ	1
13	58408	BAR - BOLTING	2
14	1018839	BOLT-HEX: 1.0 x 7.00 NC GR8 ZP	4
15	1013539	WASHER-LOCK: 1.00 ZP	4
16	1012664	NUT-HEX: 1.00 NC GR2 ZP	4
17	1032276	BOLT-HEX: 1.0 X 3.50 NC GR8 ZP	2
18	1016970	NUT-TOPLOCK: 1.00 NC GR8 ZP	2
19	69200	CYLINDER HYD 3 X 4 4 PORT 24.5 CLOSED	1
	305293	SEAL KIT 69200 2015 AND NEWER	
20	69167	PIN-CYLINDER W/CLIPS 1.00 X 2.25	2
21	58560	FTG-ELBOW: 8MB-8MJ-90	4
22	36290	PIONEER TIP 8010-15P (#8 ORB)	4
23	65379	STUD-.375 X 3.00 UNC ZP	4
24	50714	CLAMP .50 ZP	8
25	1011586	WASHER-LOCK: .38 ZP	4
26	1011576	NUT-HEX: .38 NC GR2 ZP	4
27	69557	WLDMT-TIE ROD CLAMP 6ROW	1
	306579	WLDMT-TIE ROD CLAMP 8R/12ROW	
28	1011302	BOLT-HEX: .38 X 1.50 NC GR5 ZP	2
29	1016999	NUT-TOPLOCK: .368 NC ZP	2
30	300094	HOSE KT: STEERABLE STRUTS CENTERING	1

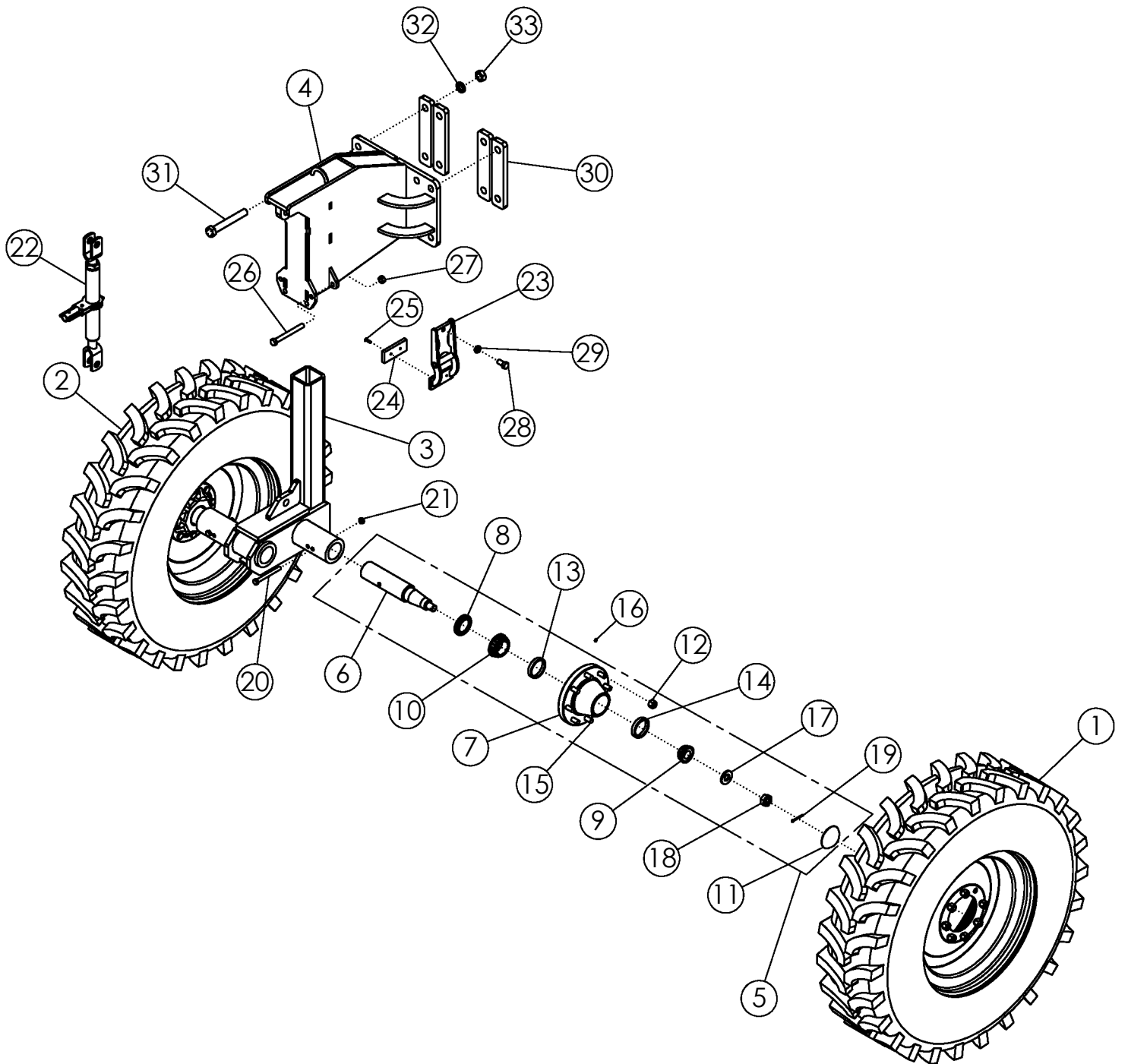

STANDARD-OFFSET 22" WIDE 2 STRUT 11.2 X 24 #68763

ITEM	PART NO.	DESCRIPTION	QTY
1	56986	TIRE-MNTD: 11.2-24 10 PLY R1 TITAN HTL RH	1
2	63992	TIRE-MNTD: 11.2-24 10 PLY R1 TITAN HTL LH	1
3	305280	WLDMT-SPINDLE HOUSING- 8" OFFSET LH	1
	305279	WLDMT-SPINDLE HOUSING- 8" OFFSET RH (NOT SHOWN)	1
4	68332	WLDMT-STD STRUT UPPER	1
5	53167	ASSY-HUB & SPINDLE: 8-BOLT W/ZERK	2
6	52954*	SPINDLE-STANDARD	1
7	53623*	HUB-WHEEL 8 BOLT	1
8	53619*	SEAL 7044-116	1
9	53620*	BEARING CONE-OUTER 7445-35	1
10	53621*	BEARING CONE-INNER 7445-52	1
11	53624*	CAP-HUB	1
12	53625*	NUT-WHEEL .625-18NF 7601-4	8
13	53622*	BEARING CUP-INNER 7446-42	1
14	52243*	BEARING CUP-OUTER 7446-28	1
15	54393*	7600-6 STUD-HUB BOLT	8
16	301490*	SELF TAPPING GREASE FITTING	1
17	1030728*	WASHER-FLAT: SAE 1.00 ZP GR8	1
18	1030726*	NUT-SPINDLE: 1.00 NF NP	1
19	1030797*	PIN-COTTER: .19 X 1.75 NP	1
20	1011618	BOLT-HEX: .50 X 5.00 NC GR5 ZP	2
21	1027461	NUT-TOPLOCK: .50 NC GR5 ZP	2
22	52407	RATCHET JACK PAINTED BLACK	1
23	69956	WLDMT-DEF STRUT CLAMP	2
24	69971	PLASTIC-STRUT CLAMP	2
25	69987	SCREW-MACH: FH-TORX 1/4-20 X 1.00	4
26	1013068	BOLT-HEX: .63 X 6.00 NC GR5 ZP	2
27	1016595	NUT-TOPLOCK: .63 NC GR5 ZP	2
28	1030703	BOLT-HEX: .63 X 1.25 NF GR5 ZP	2
29	66336	NUT-JAM: .63 NF GR2 ZP	2
30	58408	BAR-BOLTING	4
31	1018839	BOLT-HEX: 1.00 X 7.00 NC GR8 ZP	8
32	1013539	WASHER-LOCK: 1.00 ZP	8
33	1012664	NUT-HEX: 1.00 NC GR2 ZP	8

* Items are included in Item 5

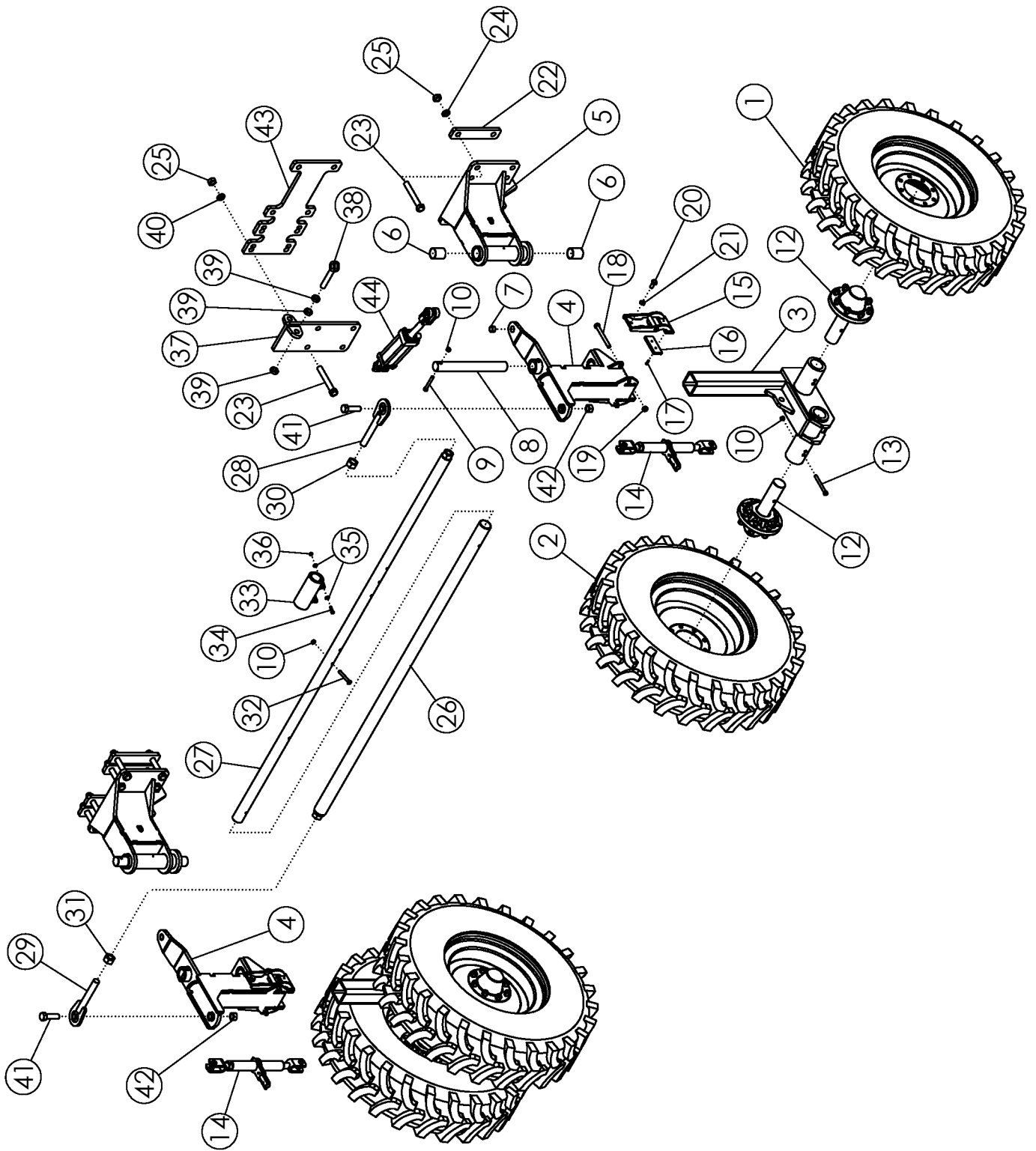

STEERABLE-OFFSET 22" WIDE 2 STRUT 11.2 X 24 #306004

ITEM	PART NO.	DESCRIPTION	QTY
1	56986	TIRE-MNTD: 11.2-24 10 PLY R1 TITAN HTL RH	2
2	63992	TIRE-MNTD: 11.2-24 10 PLY R1 TITAN HTL LH	2
3	305279	WLDMT-SPINDLE HOUSING- 8" OFFSET RH	1
	305280	WLDMT-SPINDLE HOUSING- 8" OFFSET LH	1
4	68237	WLDMT-STEERABLE STRUT UPPER	2
5	305925-1	WLDMT-PIVOT MOUNT AHC	2
6	59204	BUSHING-BORED 2.500 X 2.015	4
7	307240	BUSHING-SPRING 1.25 X 1.0 X 0.75	2
8	58274	SHAFT-STRUT PIVOT	2
9	1011612	BOLT-HEX: .50 X 3.50 NC GR5 ZP	2
10	1027461	NUT-TOPLOCK: .50 NC GR5 ZP	7
11	1011748	ZERK-GREASE: .25 UNF STRAIGHT	4
12	53167	ASSY-HUB & SPINDLE: 8-BOLT W/ZERK	4
13	1011618	BOLT-HEX: .50 X 5.00 NC GR5 ZP	4
14	52407	RATCHET JACK PAINTED BLACK	2
15	69956	WLDMT-DEF STRUT CLAMP	4
16	69971	PLASTIC-STRUT CLAMP	4
17	69987	SCREW-MACH: FH-TORX 1/4-20 X 1.00	8
18	1013068	BOLT-HEX: .63 X 6.00 NC GR5 ZP	4
19	1016595	NUT-TOPLOCK: .63 NC GR5 ZP	4
20	1030703	BOLT-HEX: .63 X 1.25 NF GR5 ZP	4
21	66336	NUT-JAM: .63 NF GR2 ZP	4
22	58408	BAR-BOLTING	8
23	1018839	BOLT-HEX: 1.00 X 7.00 NC GR8 ZP	20
24	1013539	WASHER-LOCK: 1.00 ZP	16
25	1012664	NUT-HEX: 1.00 NC GR2 ZP	20
26	306577	WLDMT-TIE ROD 85" FEMALE	1
27	306581	WLDMT-TIE ROD 107" MALE	1
28	58186	WLDMT-TIE ROD END RH	1
29	58203	WLDMT-TIE ROD END LH	1
30	1011621	NUT-HEX: 1.25 NC GR2 ZP RH	1
31	1030729	NUT-HEX: 1.25 NC GR2 ZP LH	1
32	1017719	BOLT-HEX: .50 X 3.25 NC GR5 ZP	1
33	306579	WLDMT-TIE ROD CLAMP	1
34	1011602	BOLT-HEX: .38 X 1.50 NC GR5 ZP	2
35	1014608	WASHER-FLAT: SAE .38 ZP	4
36	1016999	NUT-TOPLOCK: .38 NC GR5 ZP	2
37	306732	WLDMT-CYLINDER BRACKET ADJ	1
38	62081	BOLT-EYEBOLT: 1.00 X 6.00 ZP GR8	1
39	1026880	NUT-JAM: 1.00 NC GR2 ZP	3
40	1013539	WASHER-LOCK: 1.00 ZP	4
41	1011626	BOLT-HEX: 1.00 X 3.50 NC GR5 ZP	2
42	1016969	NUT-TOPLOCK: 1.00 NC GR8 ZP	2
43	307195	PLATE-STEERING DOGBONE UNIVERSAL	1
44	58891	CYLINDER-HYDRAULIC 4 X 8" 3000	1
	301315	SEAL KT-CYL 4 X 8, 4 X 10 3000PSI UNIVERSAL	1

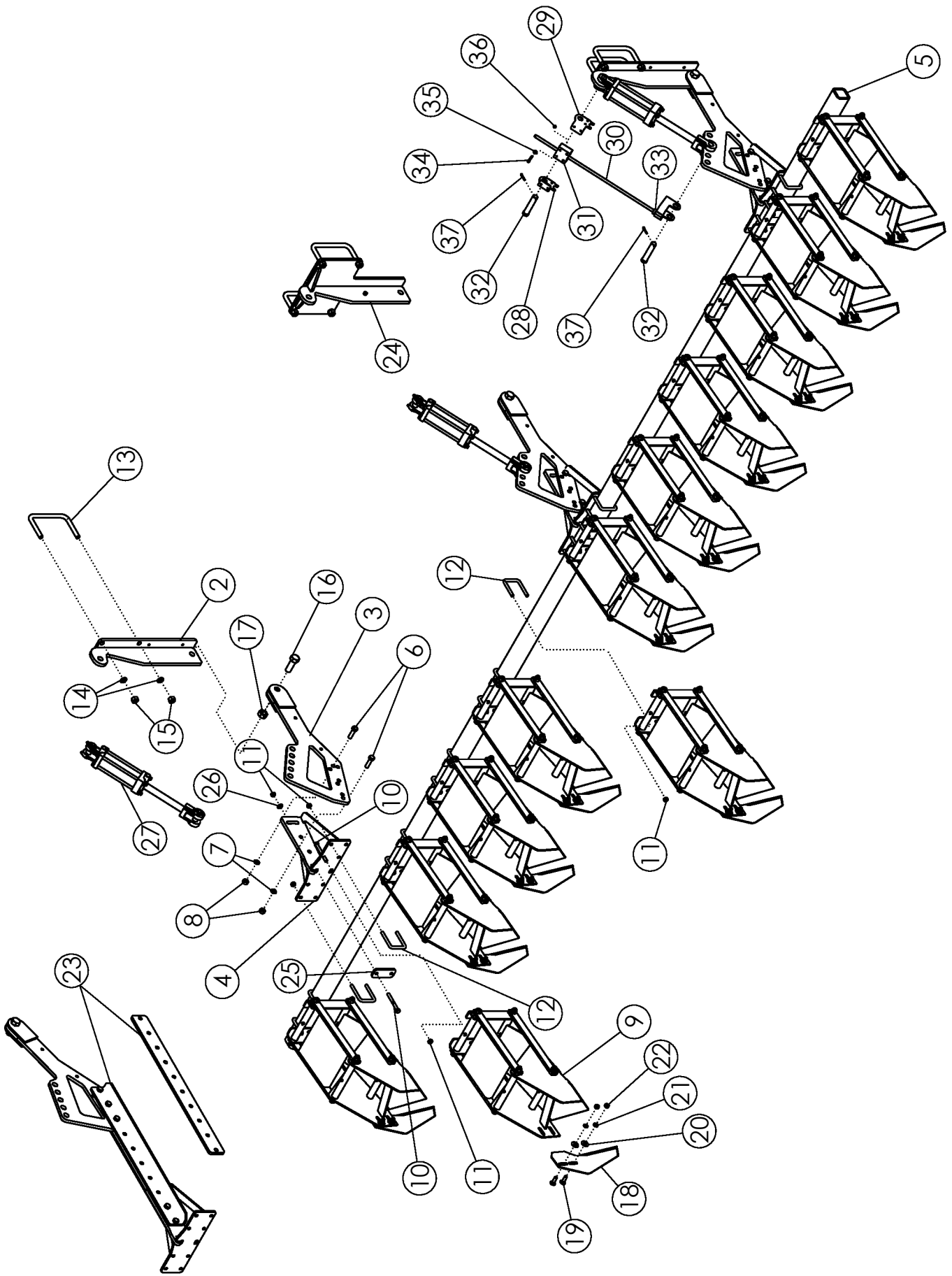

SCALPER BAR ASSEMBLY

ITEM	PART NO.	DESCRIPTION	QTY
1	58890	CYLINDER HYDRAULIC 3 X 8	3
	301314	SEAL KIT FOR 58890 UNIVERSAL	
2	68239	WLDMT - MOUNT	2
	305406	WLDMT-MOUNT EXTENDED LH	1
	305407	WLDMT-MOUNT EXTENDED RH	1
3	69126	WLDMT-SCALPER ARM MNT	3
4	69127	WLDMT-BAR MNT BRACKET	3
5	51863	SCALPER BAR 4122	1
6	1017526	BOLT-HEX .63 X 2.25 NC GR5 ZP	12
7	1011813	WASHER-LOCK: .63 ZP	12
8	1011578	NUT-HEX: .63 NC GR2 ZP	12
9	63462	ASSY-SCALPER BASKET	12
10	1013682	BOLT-HEX: .50 x 4.50 NC GR5 ZP	18
11	1027461	NUT-TOPLOCK: .50 NC GR5 ZP	66
12	69954	U-BOLT: .50 X 4.50 X 3 X 4.50	24
13	56263	U-BOLT: .75 X 5.5 X 8 X 5.5	6
14	1012061	WASHER-LOCK: .75 ZP	12
15	1011620	NUT-HEX: .75 NC GR2 ZP	12
16	1018007	BOLT-HEX: 1.0 X 3.00 NC GR5 ZP	3
17	1016969	NUT-TOPLOCK: 1.00 NC GR5 ZP	3
18	51782	SCALPER KNIFE-HEAT TREAT	12
19	1011660	BOLT-CRG: .50 X 1.50 NC GR5 ZP	24
20	1014443	WASHER-FLAT: .50 ZP	24
21	1011581	WASHER-LOCK: .50 ZP	24
22	1011577	NUT-HEX: .50 NC ZP	24
23	305183*	PLATE-SCALPER EXTENSION	3
	306101	PLATE-SCALPER EXT FLAT	
24	69011	WDLMT-CENTER CYLINDER MOUNT	3
25	51551	BAR-BASKET MOUNTING	3
26	1011584	WASHER-FLAT:SAE .50	6
27	58890	CYLINDER-HYDRAULIC 3 X 8" 3000	3
	301314	SEAL KT-CYL 3 X 8 3000PSI UNIVERSAL	
28	306962	PLATE-DEPTH GAUGE BRACKET RH	1
29	306963	PLATE-DEPTH GAUGE BRACKET LH	1
30	63999	WLDMT-BOTTOM BRACKET ZP	1
31	63383	POLY GUIDE BLOCK	1
32	63406	PIN-CLEVIS: 1.00 X 4.00 ZP	2
33	63359	COLLAR-SET: 9/16 ZP	1
34	1016211	BOLT-HEX: .25 X 2.00 NC GR5 ZP	4
35	1020416	WASHER-FLAT: .25 ZP	4
36	1030946	NUT-TOPLOCK: .25 NC GR5 ZP	4
37	1012375	PIN-COTTER: .19 X 1.50 ZP	2

*USED WITH LARGER TIRE OPTION

*OPT. 306101 USED IN TIGHT CLEARANCE SITUATIONS i.e. 44" STRUTS

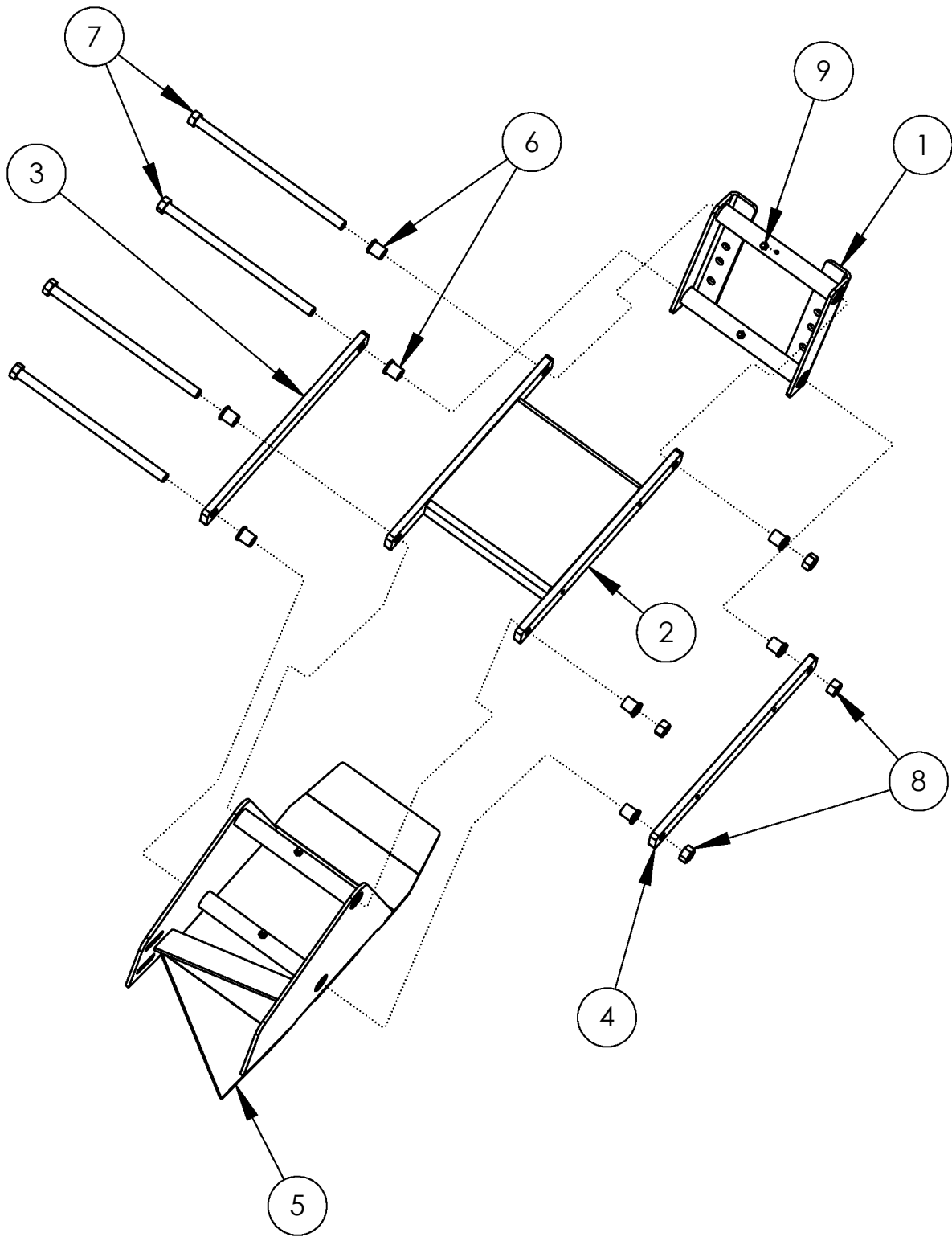

SCALPER BASKET #63462

ITEM	PART NO.	DESCRIPTION	QTY
1	63551*	WLDMT-BASKET MOUNT	1
2	306849*	WLDMT-UPPER LINK	1
3	63555*	BAR-PARALLEL LINK	1
4	306848*	BAR-PARALLEL LINK AHC THREADED PC	1
5	63550	WLDMT-BASKET FRAME	1
	306948*	WLDMT-BASKET FRAME V2	
6	306080*	BUSHING-FLANGE: .628 X 8.16 X 1.4375L	8
7	306752*	BOLT-HEX: .63 X 11.813 N GR5 ZP	4
8	59316*	NUT-CENTERLOCK: .625 NC GR5 ZP	4
9	1011748*	ZERK-GREASE .25 UNF STRAIGHT	4

* Used in 307161 ASSY-SCALPER BASKET SHORT

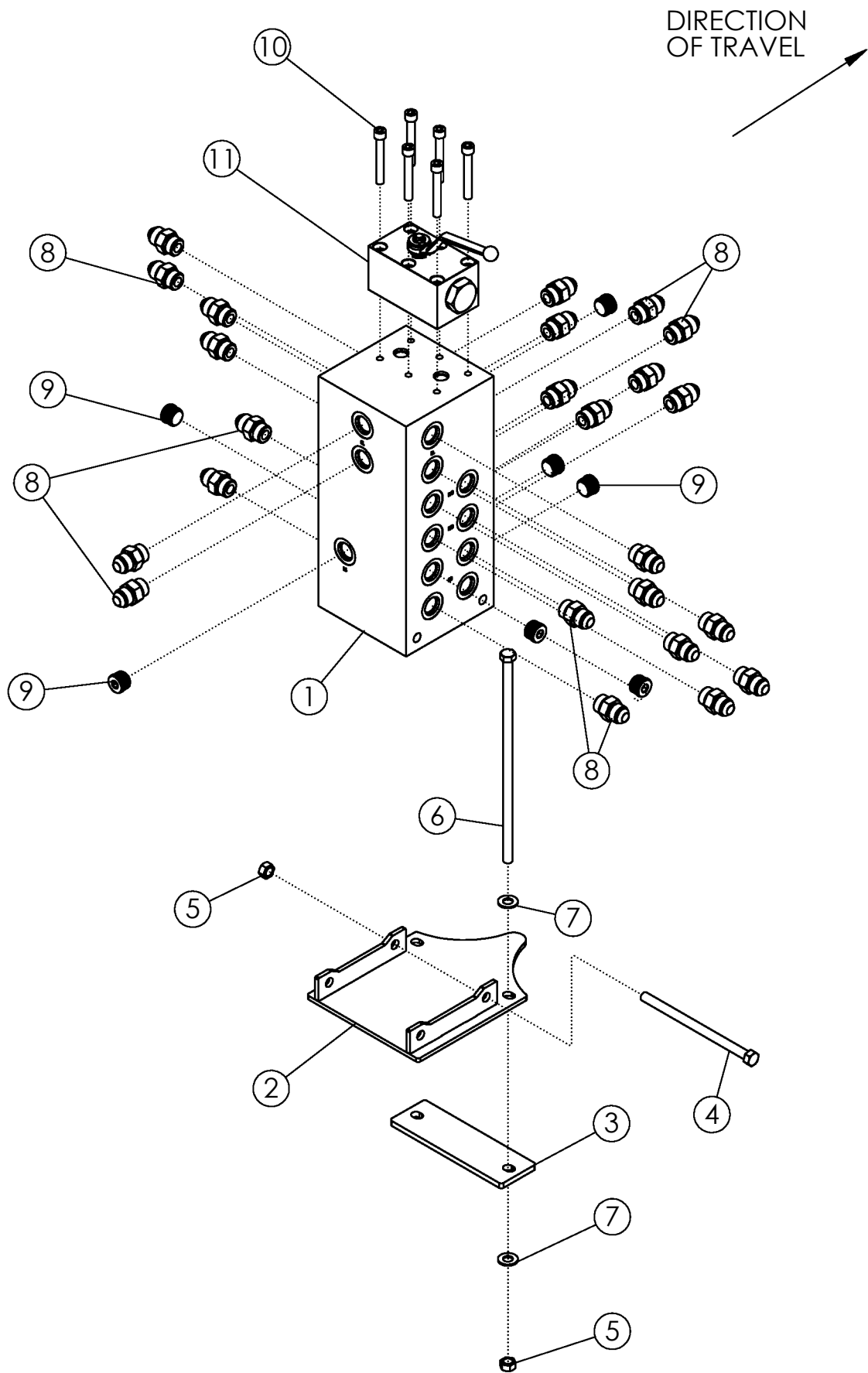

VALVE BLOCK AND MOUNT			
ITEM	PART NO.	DESCRIPTION	QTY
1	305960	HYDRAULIC BLOCK REAR DEF	1
2	305659	WLDMT-VALVE BLOCK MOUNT	1
3	305662	PLATE-VALVE BLOCK BOLTING	1
4	34925	BOLT-HEX: .38 X 6.00 NC GR5 ZP	2
5	1016999	NUT-TOPLOCK: .38 NC GR5 ZP	4
6	305663	BOLT-HEX: .38 X 10.00 NC GR5 ZP	2
7	1014608	WASHER-FLT: SAE .38 ZP	4
8	56226	FTG-ADAPTER: 8MB-8MJ	24
9	305666	FTG-PLUG: 8MB ALLEN DRIVE	AR
10	306097	BOLT-SHCS .31 X 2.25 NC ZP	6
11	306028	VALVE-BALL MANIFOLD MOUNT	1

**** BLOCK SHOWN WITH ALL OPTIONS,
IF NOT EQUIPPED BLOCK PORTS ARE
PLUGGED WITH ITEM 9.**

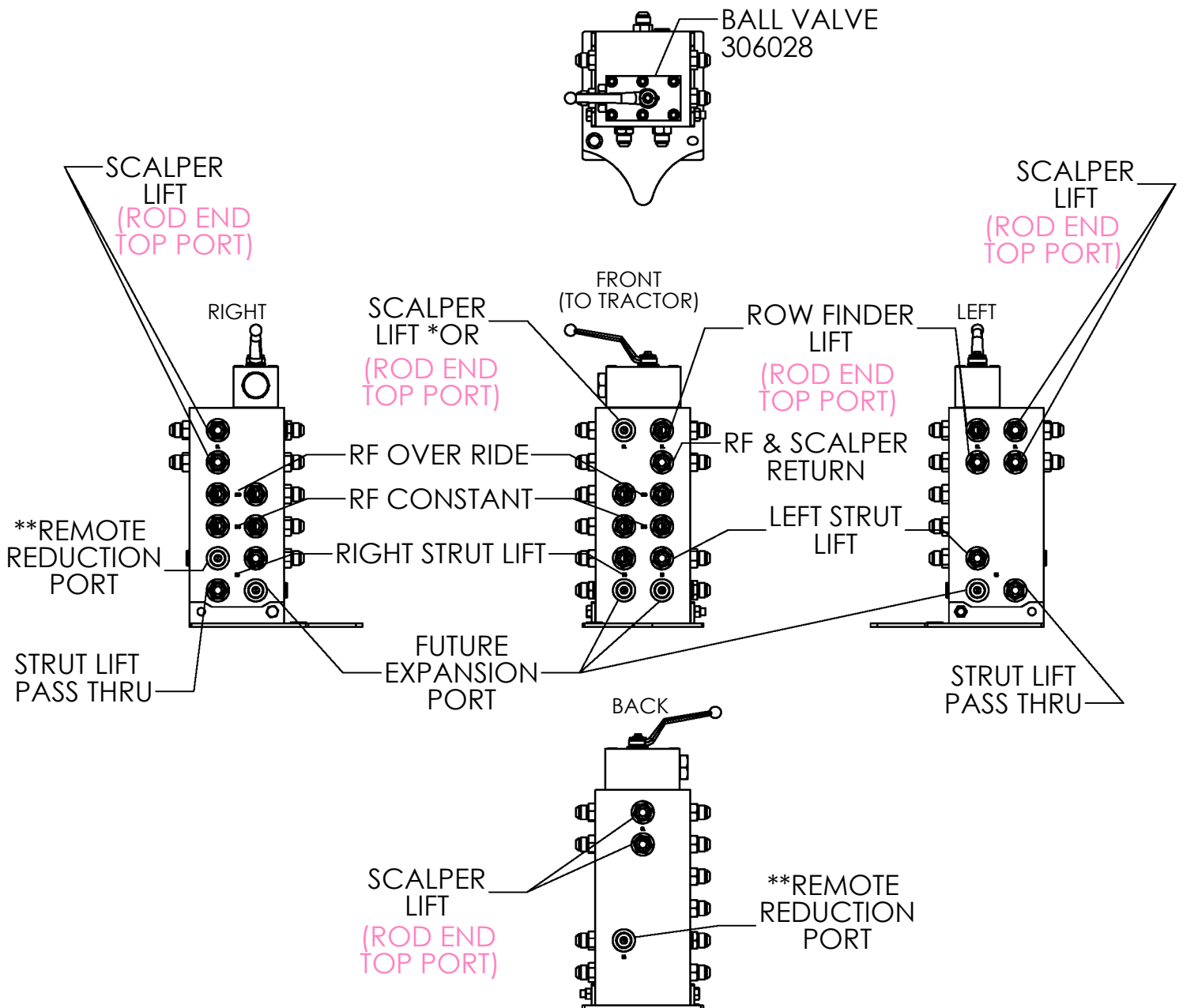

- * EITHER THE SCALPER LIFT OR ROW FINDER LIFT PORT IS USED AND THE OTHER IS PLUGGED.
- IF A FRAME MOUNTED ROW FINDER IS USED, WITH OR WITHOUT SCALPER, THE ROW FINDER LIFT PORT IS USED IN CONJUNCTION WITH A BALL VALVE. ENABELING USE OF BOTH THE SCALPER (IF EQUIPPED) AND ROW FINDER OR ROW FINDER.
- IF A SCALPER WITHOUT FRAME MOUNTED ROW FINDER IS EQUIPPED THE SCALPER LIFT PORT IS USED AND NO BALL VALVE IS INSTALLED.

** REMOTE REDUCTION PORT ALLOWS THE ROW FINDER CONSTANT FUNCTION TO BE TIED INTO THE STRUT LIFT FUNCTION TO ELIMINATE THE NEED FOR ONE ADDITIONAL HYDRAULIC REMOTE ON THE TRACTOR. IN THIS CONFIGURATION RETRACTING OR LOWERING THE STRUTS ALSO POWERS THE ROWFINDER CONSTANT FUNCTION. WHEN EXTENDING THE STRUTS A CHECK VALVE INSTALLED ON THE ROW FINDER PROHIBITS BACKWARDS OIL FLOW.

** AN ALTERNATE OPTION TO REDUCE HYDRAULIC REMOTES REQUIRED WOULD BE TO HOOK UP THE ROW FINDER CONSTANT TO THE TRACTOR'S POWER BEYOND USING AN EXTERNAL FLOW CONTROL SET TO APPROXIMATELY 7 GPM.

CROSS SECTIONAL BLOCK VIEW

FRONT VIEW

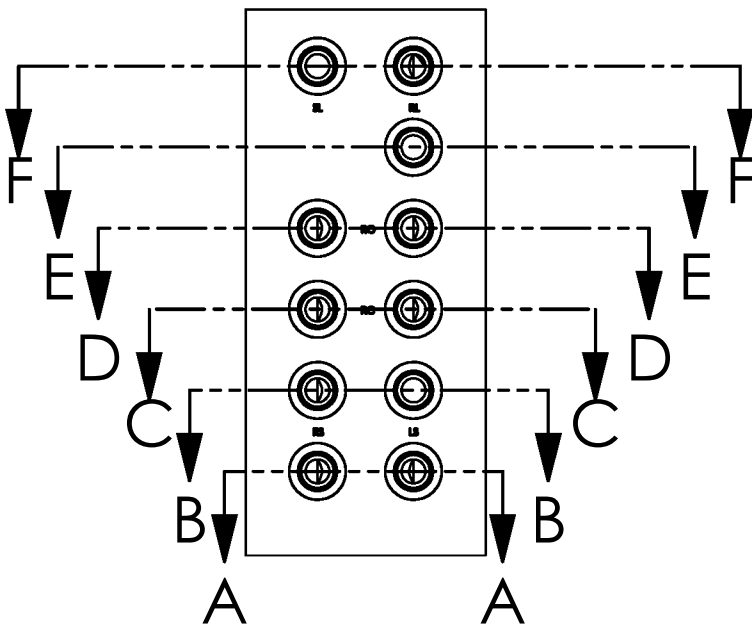

SECTION C-C

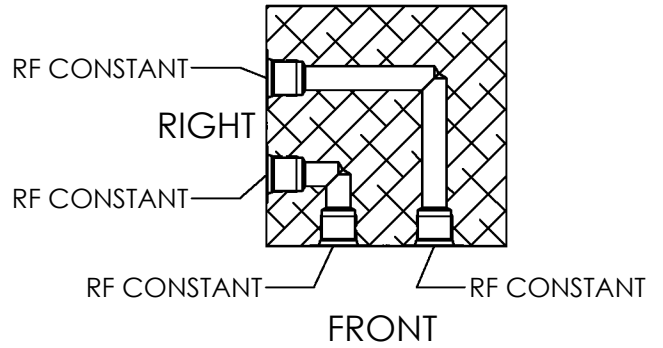

SECTION D-D

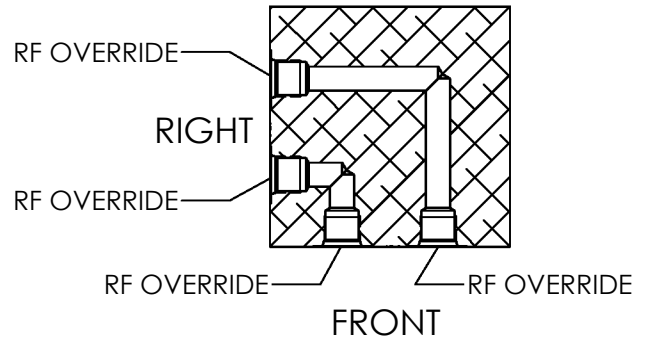

SECTION E-E

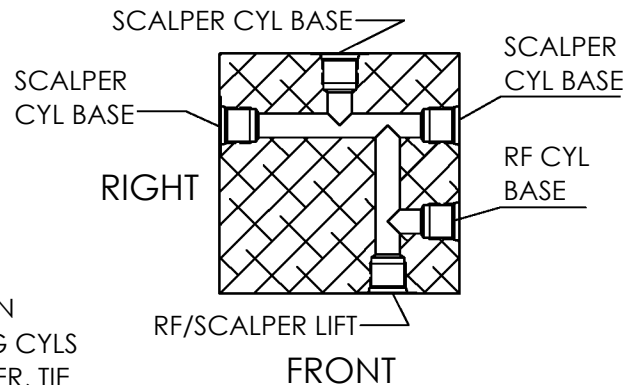

SECTION F-F

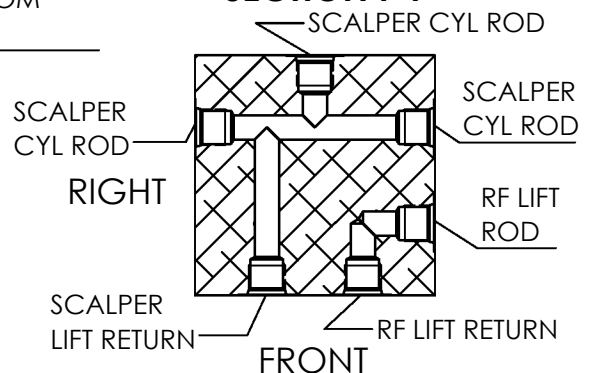

REPHASING PORT - CONNECT ROD END OF LARGER CYL TO BASE END OF SMALLER CYL FOR STD REAR LIFT

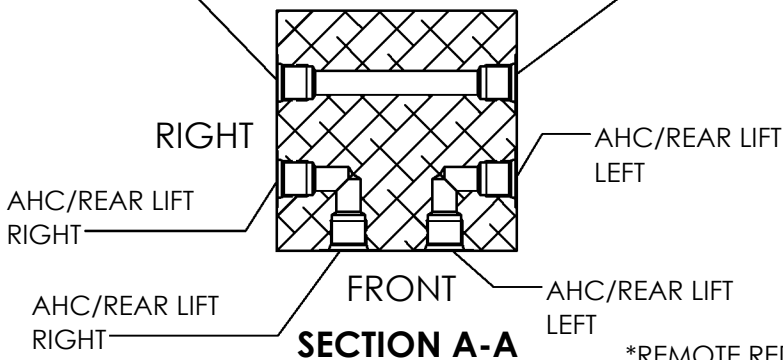

SECTION A-A

*REMOTE REDUCTION PORT W/ REPHASING CYLS - IF RH CYL IS SMALLER, TIE THIS INTO RC OF THE STEERING BLOCK; IF LH CYL IS SMALLER, TIE THIS TO INPUT BOTTOM SUPPLY OF RF VALVE

*REMOTE REDUCTION PORT W/ REPHASING CYLS - IF RH CYL IS SMALLER, TIE THIS INTO INPUT BOTTOM SUPPLY OF RF VALVE; IF LH CYL IS SMALLER, TIE THIS TO RC OF THE STEERING BLOCK

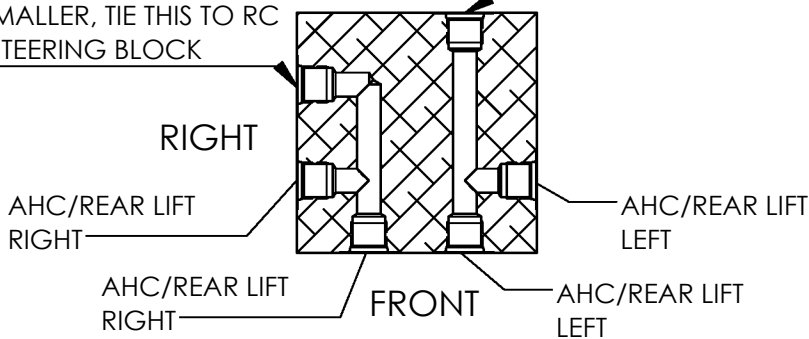

SECTION B-B

BALL VALVE IS USED WITH RF RETURN WHEN FRAME MNT RF AND SCALPERS ARE USED

IF CENTERING STEERING
USE INSIDE HOLES

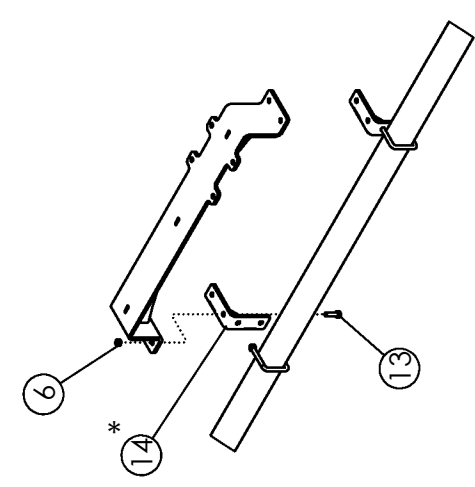
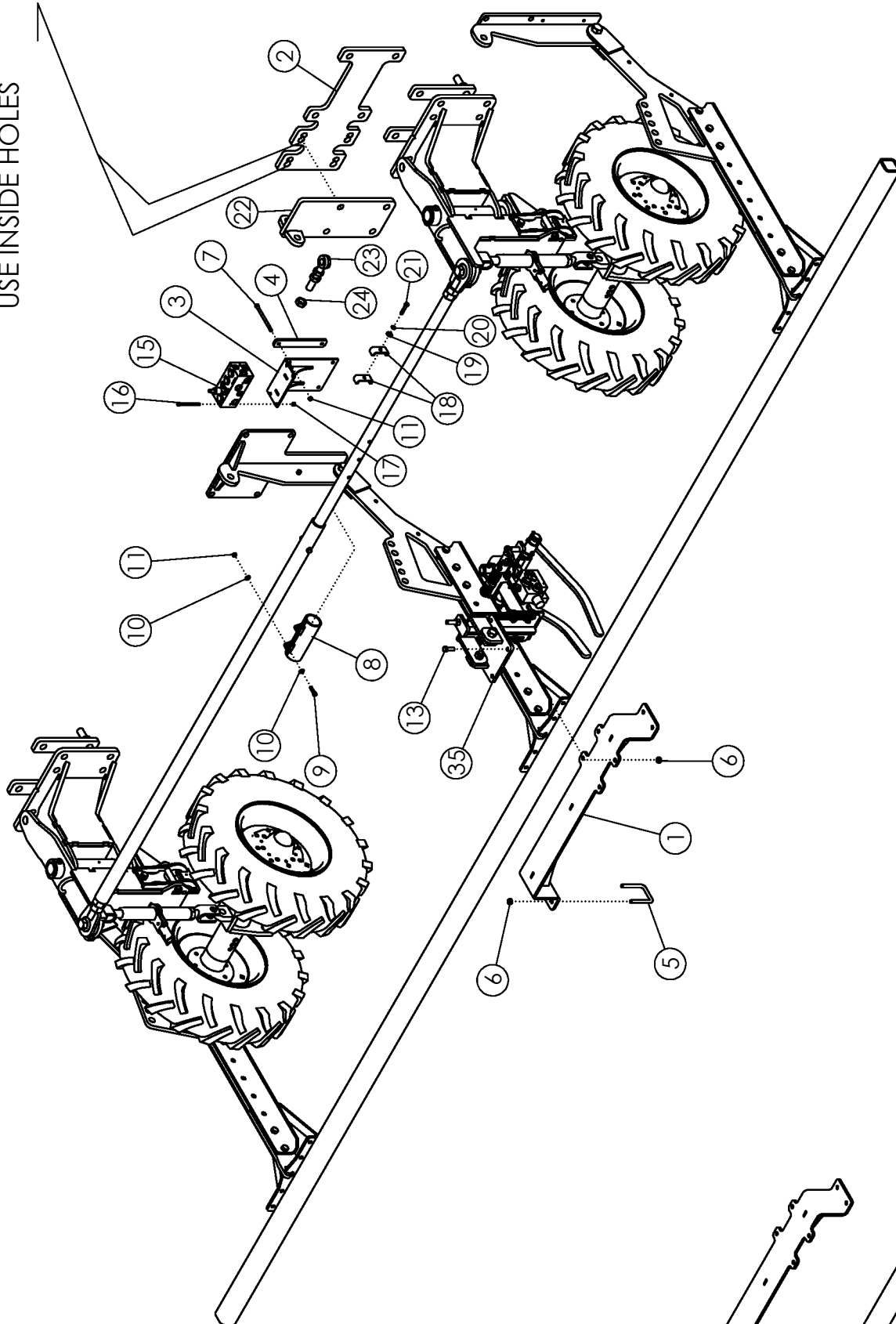

NON-AMITY SCALPER MOUNTING

ROW FINDER- SCALPER MOUNTED 12 ROW			
ITEM	PART NO.	DESCRIPTION	QTY
1	69972	WLDMT-DEF ROW FINDER MOUNT	1
2	307195	PLATE-STEERING DOGBONE UNIVERSAL	1
3	69996	WLDMT-DEF VALVE MNT	1
4	64288	PLATE-BRACKET BACKING	2
5	69954	U-BOLT: .50 X 4.50 X 3 X 4.50	2
6	1027461	NUT-TOPLOCK: .50 NC GR5 ZP	8 OR 12*
7	64289	BOLT-HEX: .38 X 5.50 NC GR5 ZP	4
8	69557	WLDMT-TIE ROD CLAMP	1
9	1011602	BOLT-HEX: .38 X 1.50 NC GR5 ZP	2
10	1014608	WASHER-FLT: SAE .38 ZP	4
11	1016999	NUT-TOPLOCK: .38 NC GR5 ZP	6
12	**NOTE**	HYDRAULIC ROW FINDER	1
13	1011608	BOLT-HEX: .50 X 1.75 NC GR 5 ZP	4 OR 8*
14	69454*	WLDMT-RF MOUNT EXTENSION	2
15	69999	VALVE-DEF RF RETURN	1
16	1030778	BOLT-HEX: .31 X 4.00 NC GR5 ZP	2
17	1030700	NUT-TOPLOCK: .31 NC GR5 ZP	2
18	50714	CLAMP .50" ZP	10
19	1014608	WASHER-FLAT: SAE .38 XP	5
20	1011586	WASHER-LOCK: .38 ZP	5
21	1013239	BOLT-HEX: .38 X 3.00 NC GR5 ZP	4
22	306732	WLDMT-CYLINDER BRACKET ADJ	1
23	62081	BOLT-EYEBOLT: 1.00 X 6.00 GR8 ZP	3

****NOTE****

- ROWFINDER NEEDS TO BE OPEN CNETER (PLUG REMOVED)
- PLACE ROWFINDER ON THE FIRST ROW RIGHT OF CENTER
- FOR PARTS, REFERENCE ROWFINDER MANUAL PAGE (M4770)

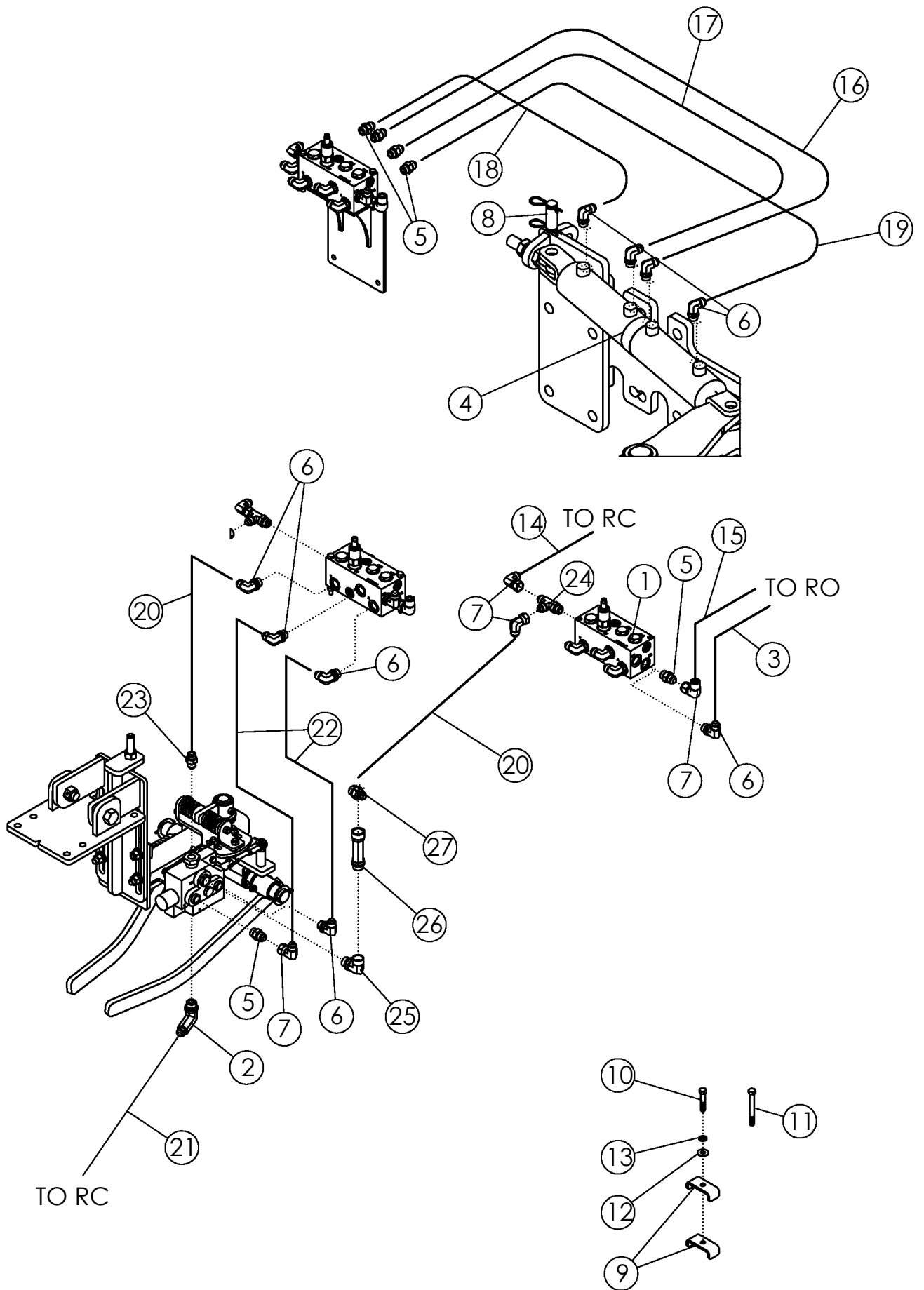

SCALPER MOUNTED ROW FINDER HYDRAULICS

ITEM	PART NO.	DESCRIPTION	QTY
1	69999	VALVE-DEF ROWFINDER RETURN	1
2	306712	FTG-ELBOW: 10MB-8MJ-90L	1
3	69571	HOSE: .50 X 258 8MB-8FJX90	1
	305676	HOSE: .50 X 027 8FJX-8FJX90	
4	69200	CYLINDER-HYD 3 X 4 4PORT 23.5 CLOSED	1
	35293	SEAL KIT 2015 AND NEWER	
5	56226	FTG-ADAPTER: 8MB-8MJ	11
6	58560	FTG-ELBOW: 8MB-8MJ 90	9
7	57668	FTG-ELBOW: 8MJ-8FJX 90	4
8	69167	PIN-CYLINDER W/CLIPS 1.00 X 2.25	2
9	50714	CLAMP .50" ZP	10
10	1011603	BOLT-HEX: .38 X 1.75 NC GR5 ZP	1
11	1013239	BOLT-HEX: .38 X 3.00 NC GR5 ZP	4
12	1014608	WASHER-FLAT: SAE .38 ZP	5
13	1011586	WASHER-LOCK: .38 ZP	5
14	69570	HOSE: .50 X 252 8FJX-8MB	1
	305675	HOSE: .50 X 017 8FJX-8FJX	
15	69572	HOSE: .50 X 258 8MB-8FJX90L	1
	305677	HOSE: .50 X 027 8FJX-8FJX 90L	
16	305043	HOSE: .50 X 086 X 8FJX-8FJX90 (6R/8R)	1
	69564	HOSE: .50 X 108 8FJX-8FJX90 (9R/12R)	
17	305044	HOSE: .50 X 086 X 8FJX-8FJX90L (6R/8R)	1
	69565	HOSE: .50 X 108 8FJX-8FJX90L (9R/12R)	
18	305045	HOSE: .50 X 092 X 8FJX-8FJX90L (6R/8R)	1
	69566	HOSE: .50 X 114 8FJX-8FJX90L (9R/12R)	
19	305046	HOSE: .50 X 080 X 8FJX-8FJX90 (6R/8R)	1
	69567	HOSE: .50 X 102 8FJX-8FJX90 (9R/12R)	
20	1024421	HOSE: .50 X 090 8FJX-8FJX	2
21	69569	HOSE: .50 X 336 8MB-8FJX90	1
	305683	HOSE: .50 X 096 8FJX-8FJX90	
22	305578	HOSE: .50 X 093 X 8FJX-8FJX	2
23	306856	FTG-ADAPTER: 8MB-8MJ W/ .063" ORIFICE	1
24	63016	FTG-TEE: 8MB-8MJ-8MJ	1
25	306711	FTG-ELBOW: 10MB-10FB-90	1
26	301016	VALVE-CHECK: 10MB-10FB 5000 PSI	1
27	58195	FTG-ADAPTER: 10MB-8MJ	1

IF CENTERING STEERING
USE INSIDE HOLES

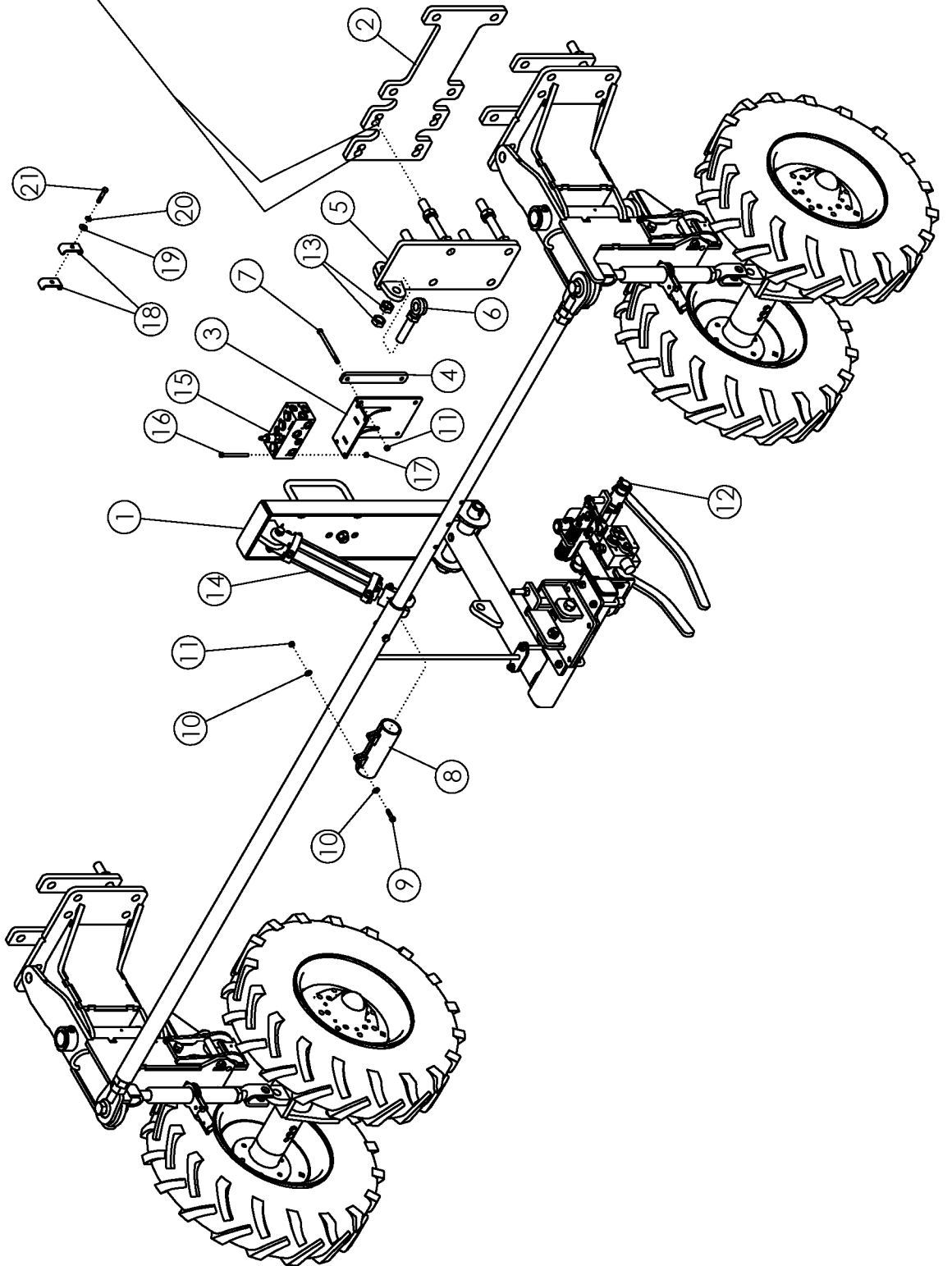

ROW FINDER - FRAME MOUNTED

ITEM	PART NO.	DESCRIPTION	QTY
1	305055	ASSY-DEF ROW FINDER MOUNT	1
2	307195	PLATE-STEERING DOGBONE UNIVERSAL	1
3	69996	WLDMT-DEF VALVE MNT	1
4	64288	PLATE-BRACKET BACKING	2
5	306732	WLDMT-CYLINDER BRACKET ADJ	1
6	62081	BOLT-EYEBOLT: 1.00 X 6.00 GR8 ZP	1
7	64289	BOLT-HEX: .38 X 5.50 NC GR5 ZP	4
8	69557	WLDMT-TIE ROD CLAMP	1
9	1011602	BOLT-HEX: .38 X 1.50 NC GR5 ZP	2
10	1014608	WASHER-FLT: SAE .38 ZP	4
11	1016999	NUT-TOPLOCK: .38 NC GR5 ZP	6
12	**NOTE**	HYDRAULIC ROW FINDER	1
13	1026880	NUT-JAM: 1.00 NC GR2 ZP	3
14	321936	CYLINDER 2 X 8	1
15	69999	VALVE-DEF RF RETURN	1
16	1030778	BOLT-HEX: .31 X 4.00 NC GR5 ZP	2
17	1030700	NUT-TOPLOCK: .31 NC GR5 ZP	2
18	50714	CLAMP .50" ZP	10
19	1014608	WASHER-FLAT: SAE .38 XP	5
20	1011586	WASHER-LOCK: .38 ZP	5
21	1013239	BOLT-HEX: .38 X 3.00 NC GR5 ZP	4

****NOTE****

- ROWFINDER NEEDS TO BE OPEN CENTER (PLUG REMOVED)
- PLACE ROWFINDER ON THE FIRST ROW RIGHT OF CENTER
- FOR PARTS, REFERENCE ROWFINDER MANUAL PAGE (M4770)

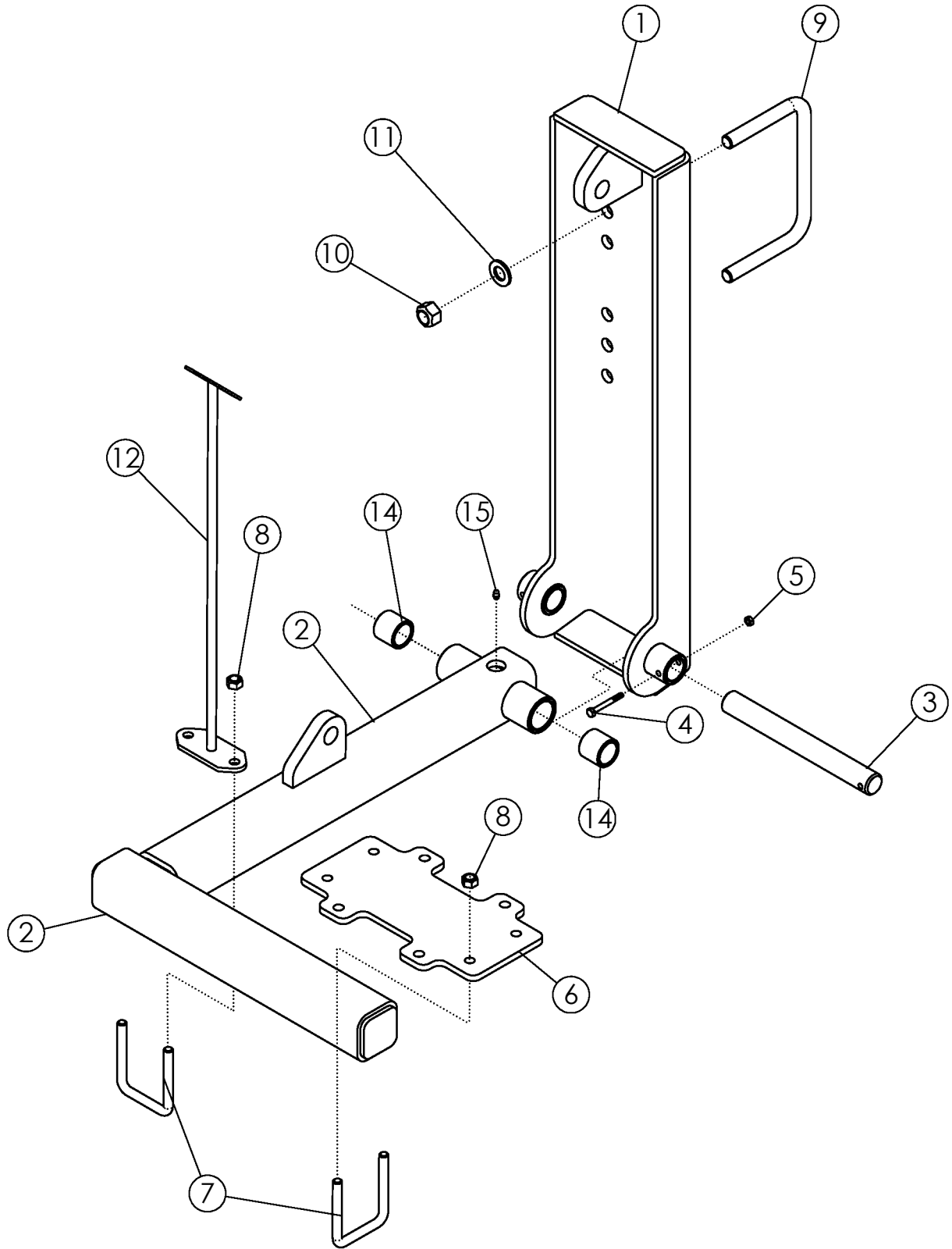

ASSY - DEF ROW FINDER MOUNT

ITEM	PART NO.	DESCRIPTION	QTY
1	305057	WLDMT-ROW FINDER MOUNT UPPER	1
2	305058	ASSY-ROW FINDER LOWER W/ BUSHINGS	1
3	305053	SHAFT-ROW FINDER	1
4	1013942	BOLT-HEX: .25 X 2.25 NC GR5	1
5	1030946	NUT-TOPLOCK: .25 NC GR5 ZP	1
6	305056	PLATE-DEF FR MOUNT (1 ROW)	1
7	69954	U-BOLT: .500 X 4.00 X 3 X 4.00	3
8	1027461	NUT-TOPLOCK: .50 NC GR5 ZP	6
9	56263	U-BOLT: .75 X 5.5 X 8 X 5.5	2
10	1017000	NUT-TOPLOCK: .75 NC GR5 ZP	4
11	1012634	WASHER-FLAT: SAE .75 ZP	4
12	305410	WLDMT-INDICATOR RF FRAME MOUNT	1
13	65332	DECAL-RED/ORANGE FLUORESCENT (NOT SHOWN)	1
14	56939	BUSHING-OILITE: 1.25 X 1.625 X 1.5L	2
15	1011748	ZERK-GREASE: .25 UNF STRAIGHT	1

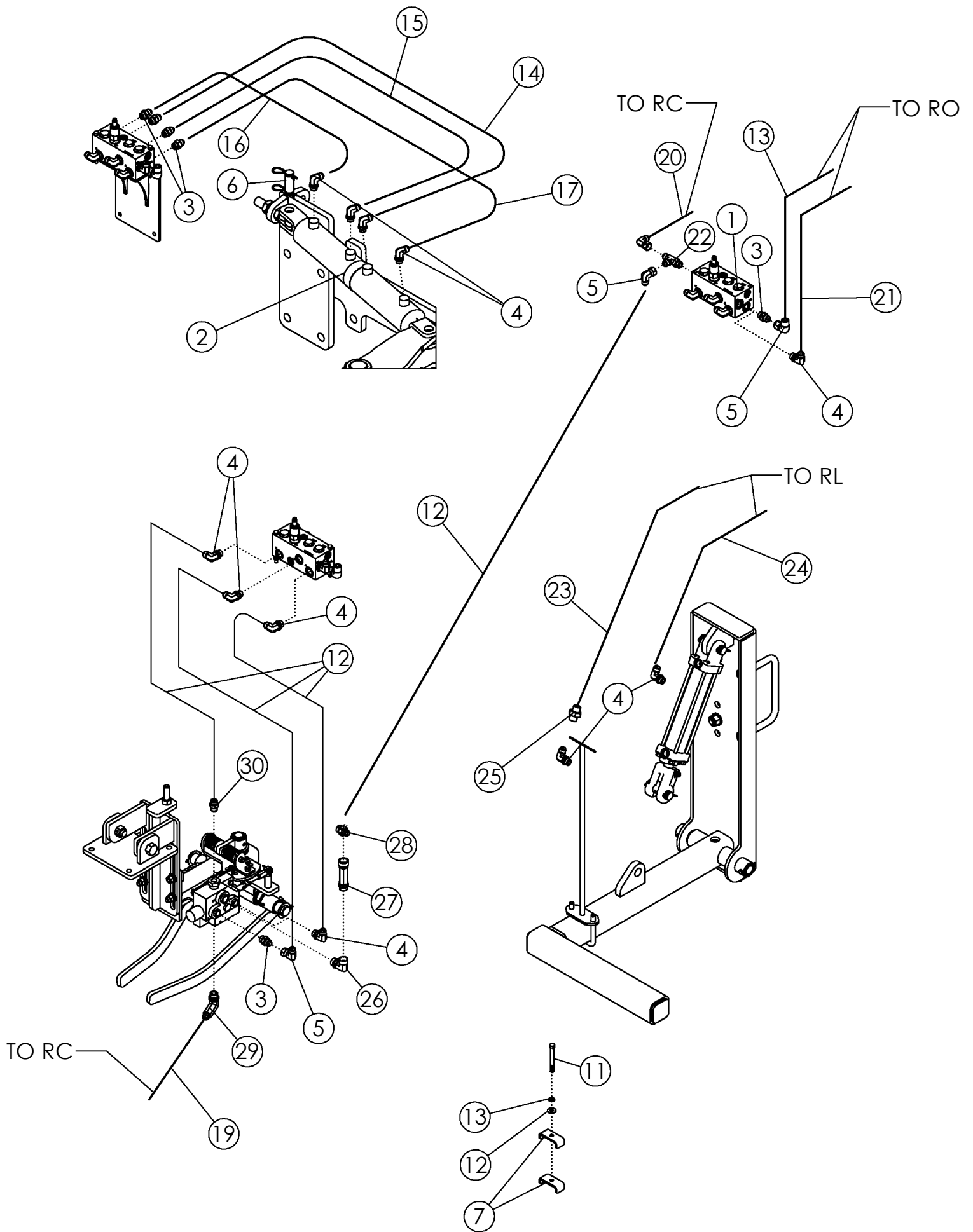

ROW FINDER HYDRAULICS - FRAME MOUNTED

ITEM	PART NO.	DESCRIPTION	QTY
1	69999	VALVE-DEF ROWFINDER RETURN	1
2	69200	CYLINDER-HYD 3 X 4 4PORT 23.5 CLOSED	1
3	56226	FTG-ADAPTER: 8MB-8MJ	10
4	58560	FTG-ELBOW: 8MB-8MJ 90	11
5	57668	FTG-ELBOW: 8MJ-8FJX 90	4
6	69167	PIN-CYLINDER W/CLIPS 1.00 X 2.25	2
7	50714	CLAMP .50" ZP	10
8	1011603	BOLT-HEX: .38 X 1.75 NC GR5 ZP	1
9	1013239	BOLT-HEX: .38 X 3.00 NC GR5 ZP	4
10	1014608	WASHER-FLAT: SAE .38 ZP	5
11	1011586	WASHER-LOCK: .38 ZP	5
12	300254	HOSE: .50 X 076 X 8FJX-8FJX	4
13	305677	HOSE: .50 X 027 8FJX-8FJX90L	1
	69572	HOSE: .50 X 258 X 8MB-8FJX90L	
14	69654	HOSE: .50 X 108 8FJX-8FJX90 (9R/12R)	1
	305043	HOSE: .50 X 086 8FJX-8FJX90 (6R/8R)	
15	69565	HOSE: .50 X 108 8FJX-8FJX90L (9R/12R)	1
	305044	HOSE: .50 X 086 8FJX-8FJX90L (6R/8R)	
16	69566	HOSE: .50 X 114 8FJX-8FJX90L (9R/12R)	1
	305045	HOSE: .50 X 092 8FJX-8FJX90L (6R/8R)	
17	69567	HOSE: .50 X 102 8FJX-8FJX90 (9R/12R)	1
	305046	HOSE: .50 X 080 8FJX-8FJX90 (6R/8R)	
18	305679	HOSE: .50 X 074 10FJX-8FJX90	1
19	64265	HOSE: .50 X 072 8FJX-8FJX90	1
	69569	HOSE: .50 X 336 X 8MB-8FJX90	
20	305675	HOSE: .50 X 017 8FJX-8FJX	1
	69570	HOSE: .50 X 252 X 8FJX-8MB	
21	305676	HOSE: .50 X 027 8FJX-8FJX90	1
	69571	HOSE: .50 X 258 X 8MB-8FJX90	
22	63016	FTG-TEE: 8MB-8MJ-8MJ	1
23	305441	HOSE: .38 X 040 8FJX-8FJX 90	1
24	305426	HOSE: .38 X 030 8FJX-8FJX 90	1
25	1019844	FTG-RESTRICTOR 8FJ-8MJ .090	1
26	306711	FTG-ELBOW: 10MB-10FB-90	1
27	301016	VALVE-CHECK: 10MB-10FB 5000 PSI	1
28	58195	FTG-ADAPTER: 10MB-8MJ	1
29	306712	FTG-ELBOW: 10MB-8MJ-90L	1
30	306856	FTG-ADAPTER: 8MB-8MJ W/ .063" ORIFICE	1

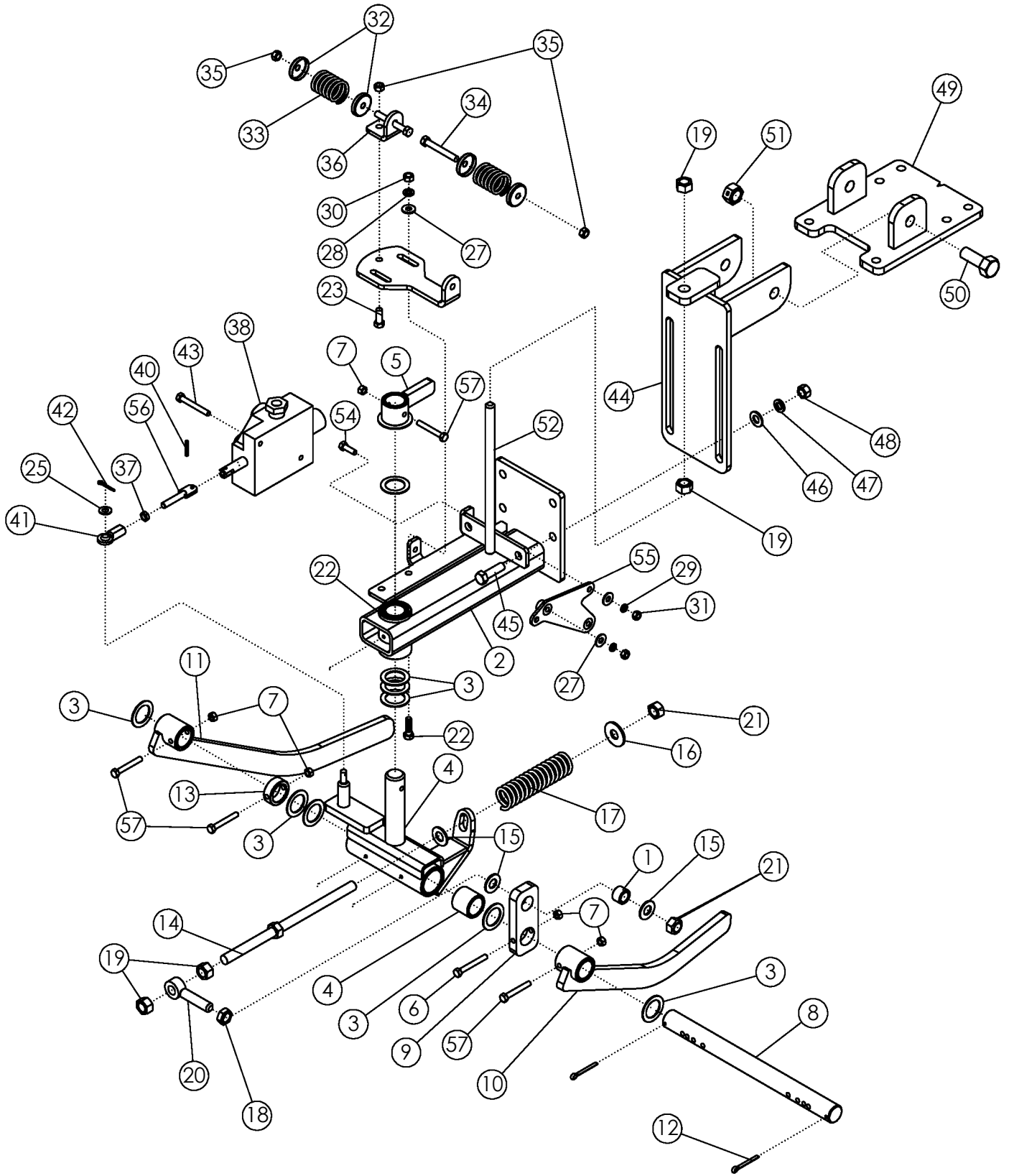

HYDRAULIC ROW FINDER

ITEM	PART NO.	DESCRIPTION	QTY
1	52567	BUSHING-ZP	1
2	62520	ASSY-MAIN FRAME	1
3	55206	BUSHING-MACH: 1.25 NR 14GA	9
4	51139	ASSY - SWIVEL	1
5	51130	WLDMT-FLIPPER	1
6	301748	BOLT-HEX: .31 X 2.50 NC GR8 ZP	1
7	301749	NUT-TOPLOCK: .31 NC GR8 ZP	5
8	51690	SHAFT ZP	1
9	52566	TENSIONER ARM	1
10	51131	SENSOR ARM-L.H.	1
11	52564	SENSOR ARM-R.H.	1
12	1030797	PIN-COTTER: .19 X 1.75 NP	2
13	51137	COLLAR	1
14	52565	ADJUSTMENT BOLT	1
15	1013004	WASHER-FLAT: SAE .63 ZP	3
16	1013024	WASHER-FLAT: .63 ZP	2
17	51692	SPRING: .21 X 1.44 OD X 6.00 15 COILS	1
18	1026259	NUT-JAM: .63 NC GR2 ZP	2
19	1011578	NUT-HEX: .63 NC GR2 ZP	3
20	51691	EYEBOLT: .63 X 3.25 ZP	1
21	1016595	NUT-TOPLOCK: .63 NC GR5 ZP	2
22	1011601	BOLT-HEX: .38 X 1.25 NC GR5 ZP	2
23	1011600	BOLT-HEX: .38 X 1.00 NC GR5 ZP	1
24	51129	PLATE	1
25	1014608	WASHER-FLT: SAE .38 ZP	1
26	1020416	WASHER-FLAT: .25 ZP	2
27	1011583	WASHER-FLAT: .31 ZP	2
28	1011586	WASHER-LOCK: .38 ZP	2
29	1029115	WASHER-LOCK: .31 ZP	2
30	1011576	NUT-HEX: .38 NC GR2 ZP	2
31	1011575	NUT-HEX: .31 NC GR2 ZP	2
32	52582	SPRING CAP	4
33	51689	SPRING	2
34	1019828	BOLT-HEX: .38 X 2.75 NC GR5 ZP	2
35	1016999	NUT-TOPLOCK: .38 NC GR5 ZP	3
36	51128	SPRING PLATE	1
37	1030792	NUT-JAM: .38 NF GR2 ZP	1
38	306698	VALVE-ROWFINDER POWER BEYOND	1
39	62540	PLATE STUD ZP	1
40	64157	PIN-ROLL: .19 X 1.125 ZP	1

CONTINUED

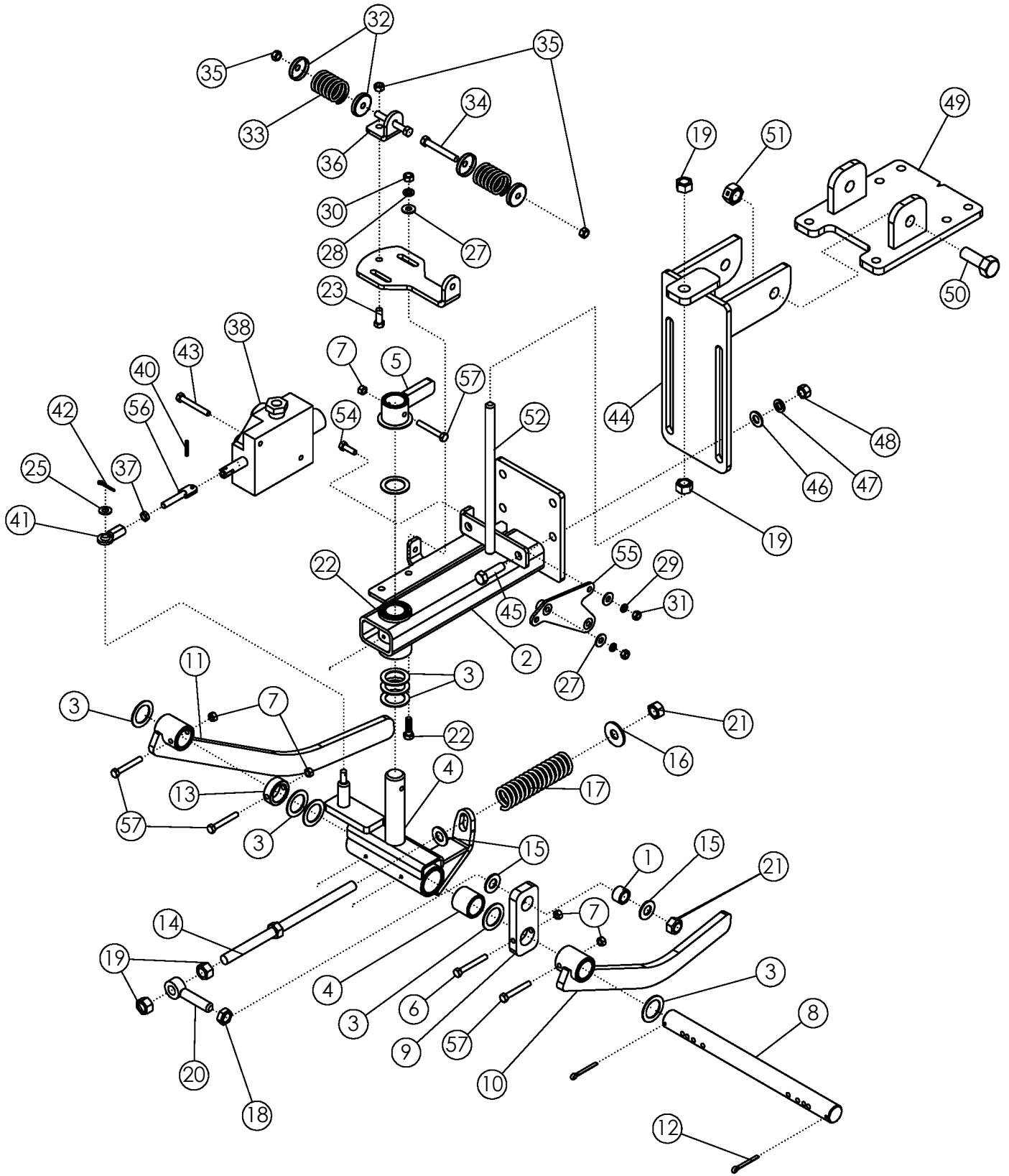

HYDRAULIC ROW FINDER (CONTINUED)

ITEM	PART NO.	DESCRIPTION	QTY
41	51136	UNIBALL COUPLING	1
42	1029137	PIN-COTTER: .13 X 1.00 ZP	1
43	1027258	BOLT-HEX: .31 X 2.50 NC GR5 ZP	2
44	52181	MOUNTING BRACKET	1
45	1011608	BOLT-HEX: .50 X 1.75 NC GR5 ZP	4
46	1011584	WASHER-FLAT: SAE .50 ZP	4
47	1011581	WASHER-LOCK: .50 ZP	8
48	1011577	NUT-HEX: .50 NC GR2 ZP	8
49	301662	WLDMT-ROW FINDER BRACKET UNIVERSAL	1
50	1012060	BOLT-HEX: .75 X 2.00 NC GR5 ZP	2
51	1013537	NUT-TOPLOCK: .75 NC GR5 ZP	2
52	62882	TIGHTENER BOLT-ZP	1
53	1011748	ZERK - GREASE	3
54	1011598	BOLT-HEX: .31 X 1.00 NC GR5 ZP	2
55	306854	WLDMT-R/F MNT PB	1
56	301750	WLDMT-STUD RF LONG ZP	1
57	301258	BOLT-HEX: .31 X 2.25 NC GR8 ZP	4

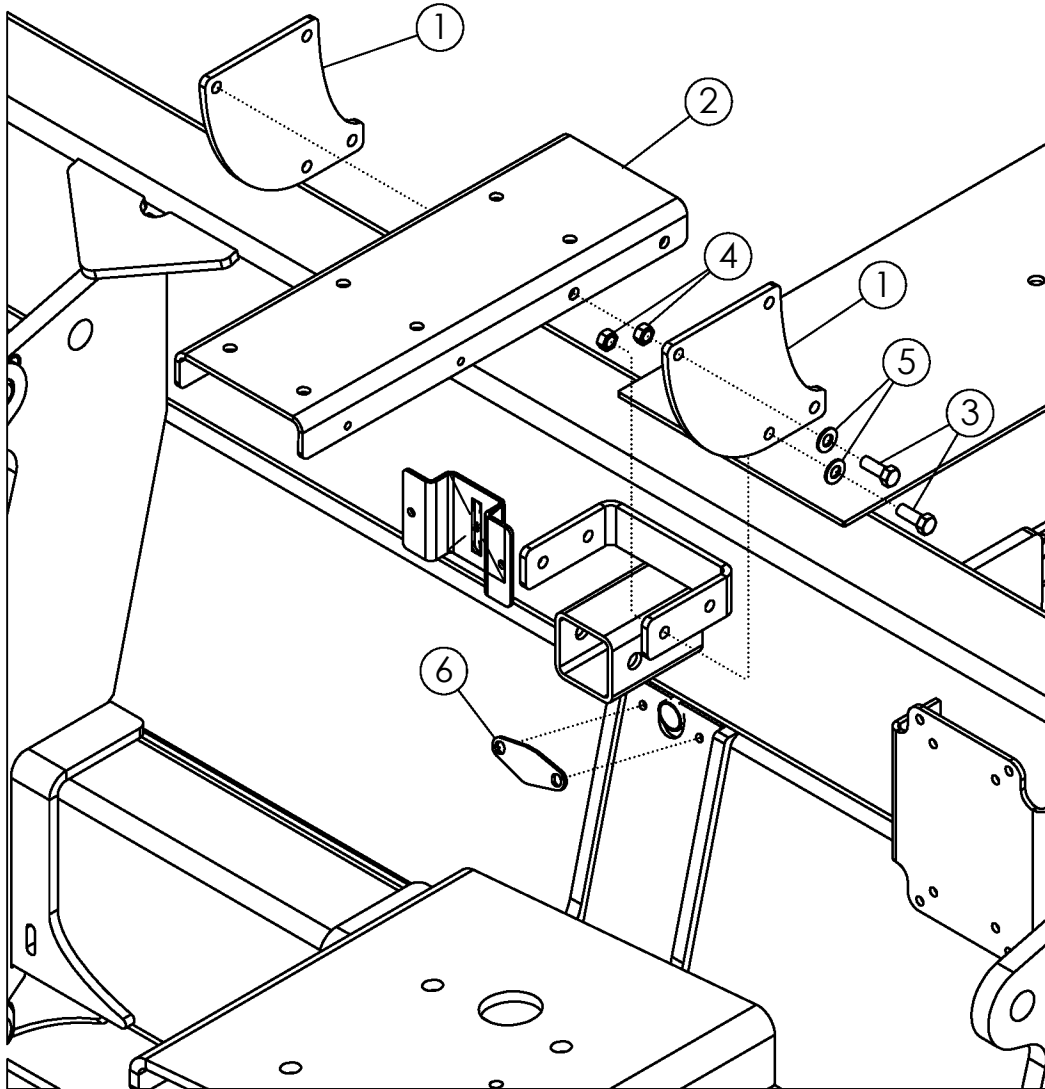

AHC/FLOATING STRUT VALVES MOUNT (00 SERIES)

ITEM	PART NO.	DESCRIPTION	QTY
1	306987	PLATE-AHC BASE EXTENDER	2
2	306988	PLATE-AHC BASE MOUNT	1
3	1011600	BOLT-HEX: .38 X 1.00 NC GR5 ZP	8
4	1016999	NUT-TOPLOCK: .38 NC GR5 ZP	8
5	1014608	WASHER-FLAT: SAE .38 ZP	8
6	307394	PLATE-HARNESS HOLE COVER	1

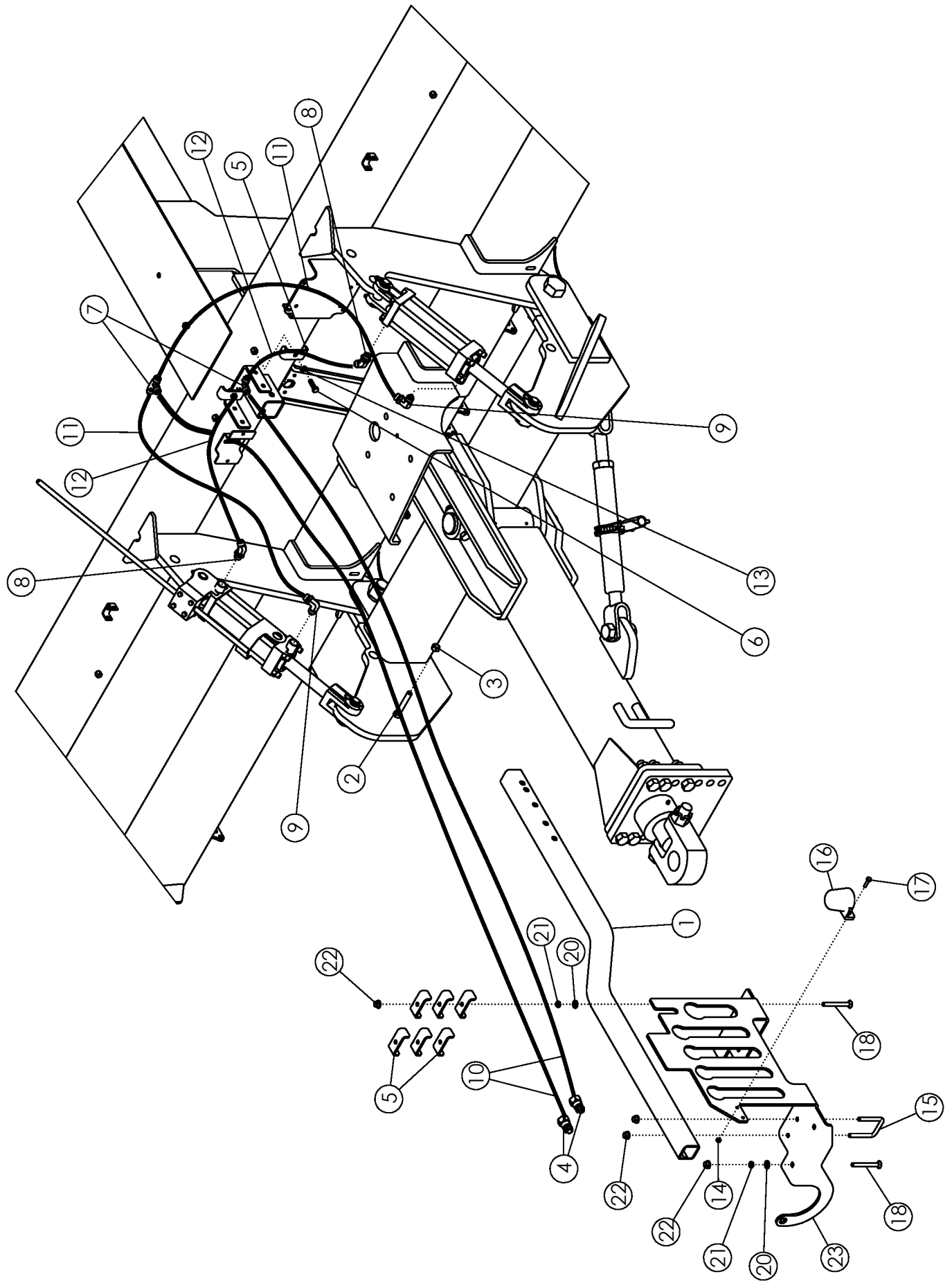

HITCH HYDRAULICS

ITEM	PART NO.	DESCRIPTION	QTY
1	301135	TUBE-HYD HOSE HOLDER PC	1
2	1011611	BOLT-HEX: .50 X 3.00 NC GR5 ZP	1
3	1027461	NUT-TOPLOCK: .50 NC GR5 ZP	1
4	36290	PIONEER TIP 8010-15 (#8 ORB)	2
5	50714	CLAMP .50 ZP	14
6	1011601	BOLT-HEX: .38 X 1.25 NC GR5 ZP	2
7	57667	FTG-TEE: 8MJ-8MJ-8MJ	2
8	58515	FTG-ELBOW: 8MB-8MJ-45	2
9	58560	FTG-ELBOW: 8MB-8MJ-90	2
10	300053	HOSE: .50 X 108 8MB-8FJX	2
11	57000	HOSE .50 X 034 8FJX-8FJX	2
12	44174	HOSE: .50 X 24 8FJX-8FJX	2
13	1011586	WASHER-LOCK: .38 ZP	2
14	1030946	NUT-TOPLOCK: .25 NC GR5 ZP	2
15	33162	U-BOLT: .375 X 3 X 2 X 3	3
16	223329	HOLDER-LIGHT PLUG	1
17	1013423	BOLT-HEX: .25 X 1.00 NC GR5 ZP	2
18	1030880	BOLT-CRG: .38 X 3.50 NC GR5 ZP	4
19	1030882	BOLT-CRG: .38 X 2.50 NC GR5 ZP	4
20	1014608	WASHER-FLAT: SAE .38 ZP	4
21	1013519	NUT-JAM: .38 NC GR2 ZP	4
22	303731	NUT-FLANGE: TOPLOCK .38 NC YZP	8
23	303797	PLATE-HYD HOSE HOLDER W/ PTO CATCH	1

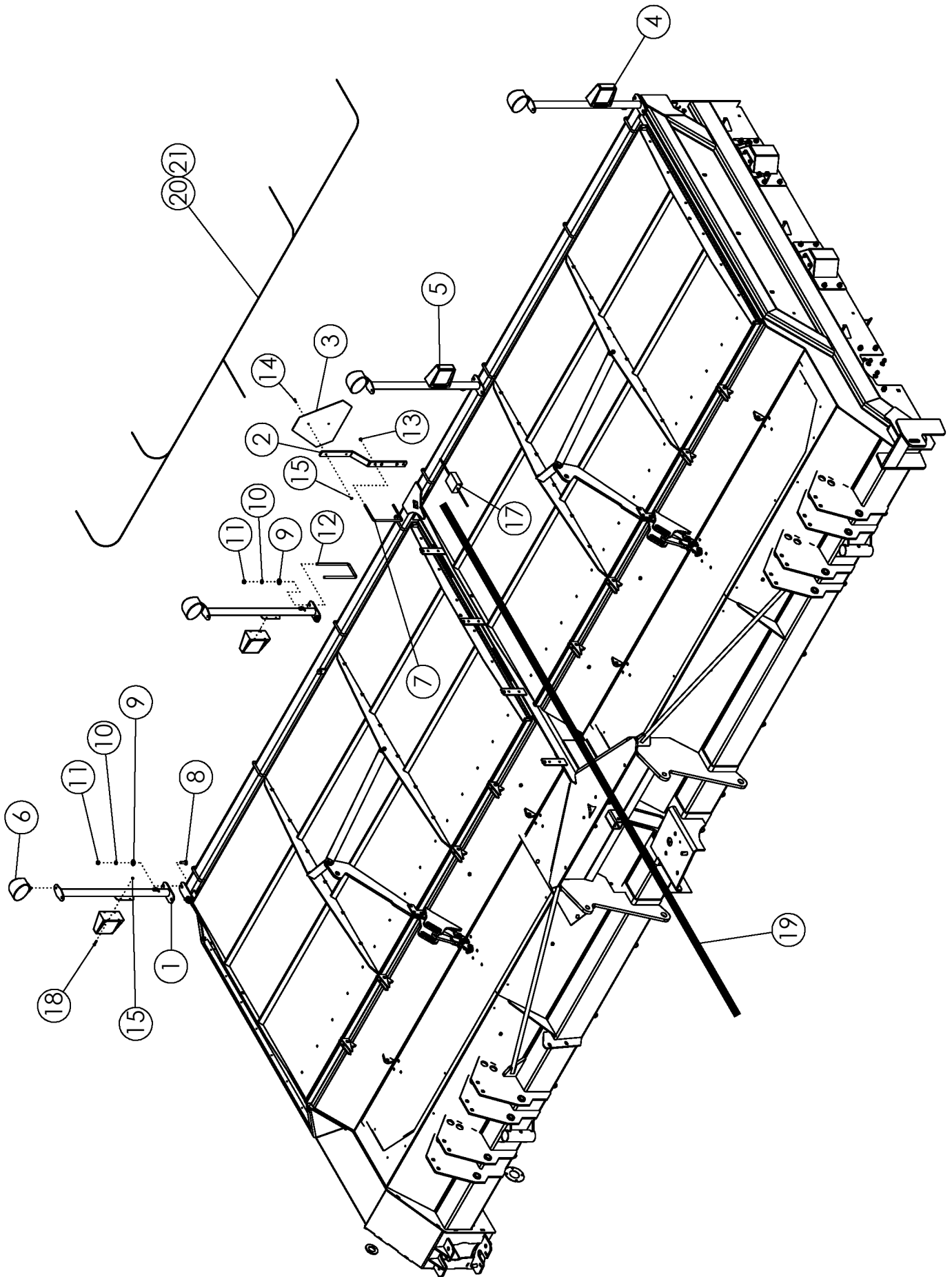

LIGHT KIT

ITEM	PART NO.	DESCRIPTION	QTY
1	305219	WLDMT-LIGHT MOUNT	4
2	64246	MOUNT-SMV SIGN	1
3	65329	SIGN-SMV ASAE	1
4	305217	LIGHT-YELLOW LAMP SAE	2
5	305218	LIGHT-RED LAMP SAE	2
6	301294	LIGHT-GROTE T26 NEAR FLOOD	4
7	64244	U-BOLT: .375 X 5.125 X 8.063 X 5.125	1
8	1011660	BOLT-CRG: .50 X 1.50 NC GR5 ZP	4
9	1014443	WASHER-FLAT: .50 ZP	8
10	1011581	WASHER-LOCK: .50 ZP	8
11	1011577	NUT-HEX: .50 NC ZP	8
12	63458	U-BOLT: .50 X 9.25 X 4.00 X 9.25 ZP	2
13	1016999	NUT-TOPLOCK: .38 NC GR5 ZP	2
14	1011595	BOLT-HEX: .25 X .75 NC GR5 ZP	2
15	1030946	NUT-TOPLOCK: .25 NC GR5 ZP	18
16	1013122	TIE-NYLON CABLE 50# X 15.50" (NOT SHOWN)	12
17	305216	MODULE-FLASHER HARNESS	1
18	1013940	BOLT-HEX: .25 X 1.25 NC GR5	16
19	305213	HARNESS-DEF LIGHT LEAD	1
20	305214	HARNESS-DEF WORK LIGHT	1
21	305215	HARNESS-DEF LGIHT	1

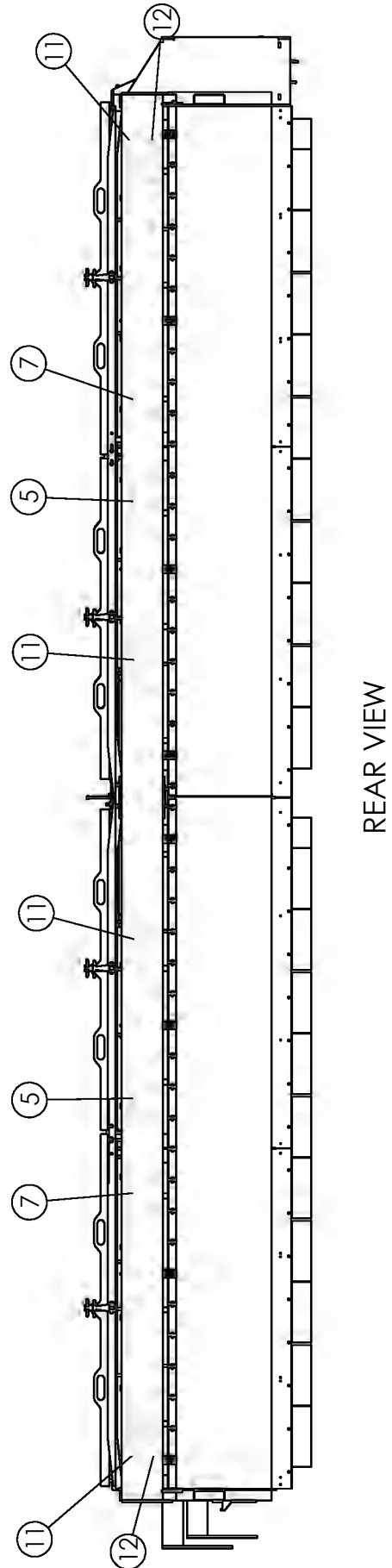
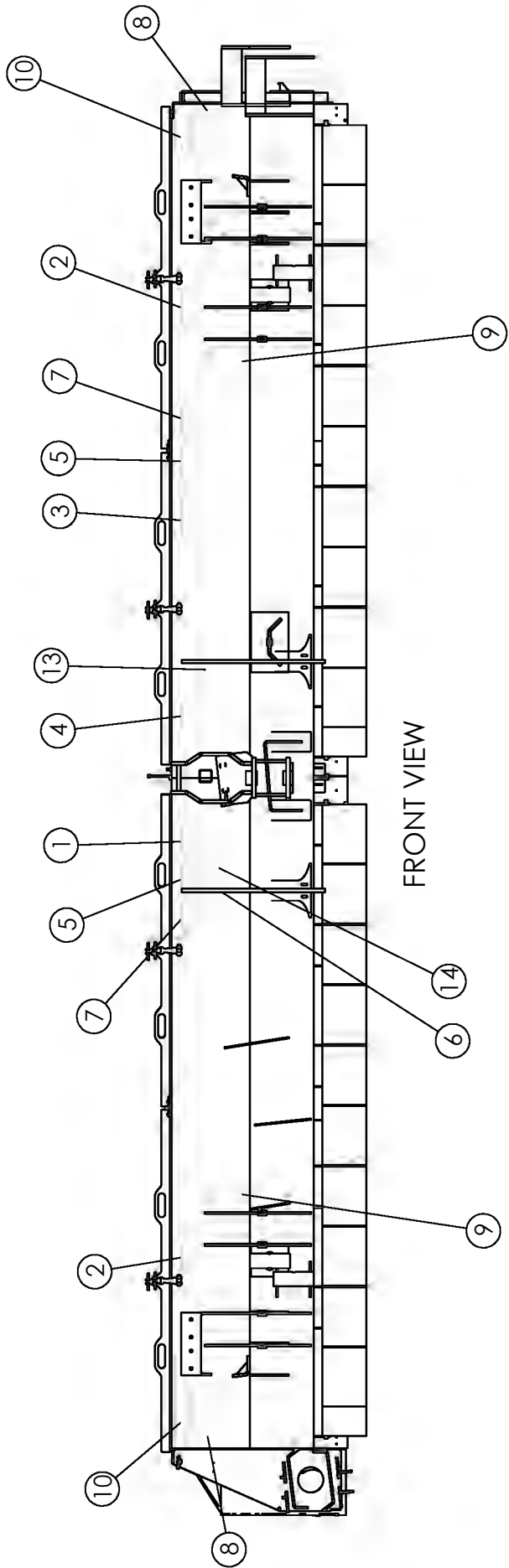

DECALS

ITEM	PART NO.	DESCRIPTION	QTY
1	52341	DECAL-WARNING	1
2	52334	DECAL-WARNING	2
3	52329	DECAL-DANGER	1
4	52339	DECAL-WARNING	1
5	52340	DECAL-DANGER	4
6	52338	DECAL DANGER	1
7	52336	DECAL-CAUTION	4
8	64617	DECAL-DANGER	2
9	63465	DECAL-LOGO	2
10	65331	DECAL-RETROFLECTIVE-YELLOW	2
11	65330	DECAL-RETROFLECTIVE-RED	4
12	65332	DECAL-RED ORANGE FLUORESCENT	2
13	62964	DECAL-WARNING	1
14	303769	DECAL-US PATENT QR CODE	1

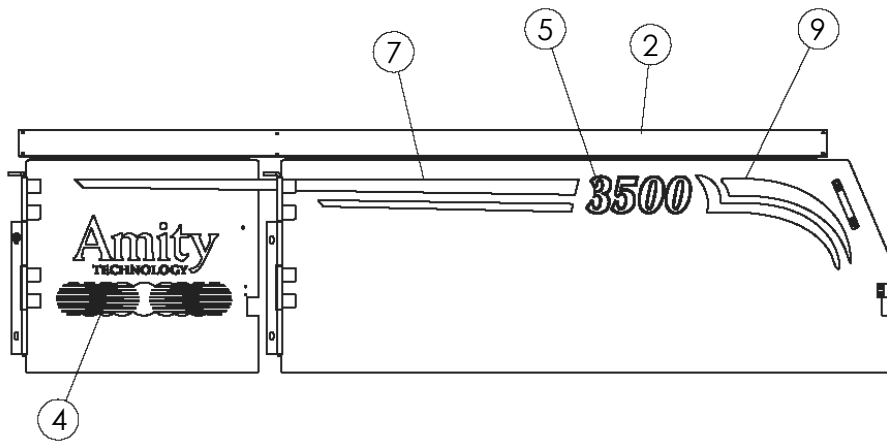

RIGHT SIDE DOOR

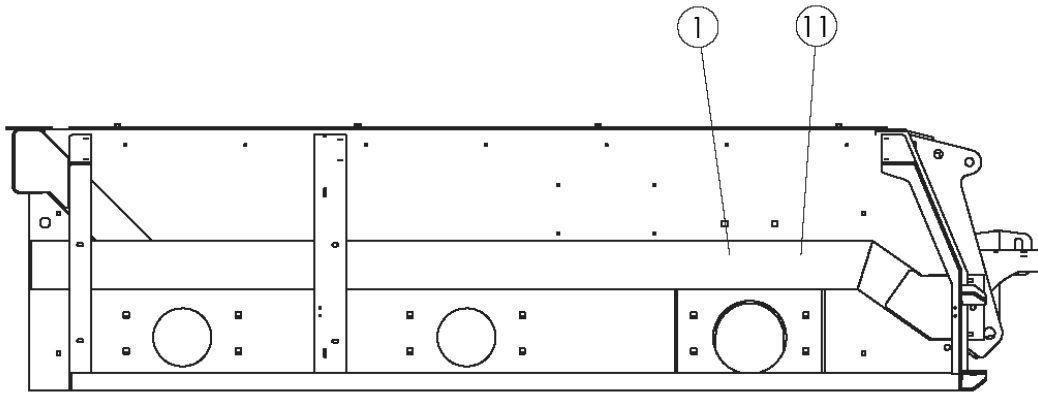

RIGHT SIDE UNDERNEATH DOOR

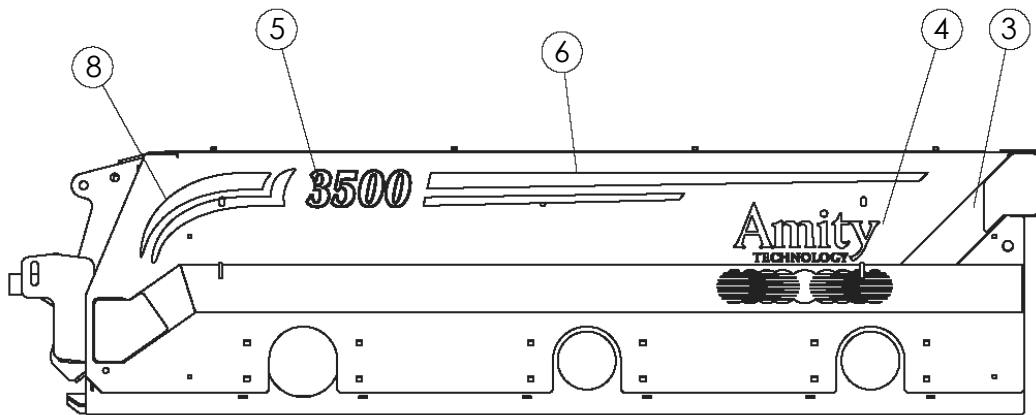

LEFT SIDE

10

DEF-00 Series Hose Color Chart	
Black	Hitch
Blue	Row Finder Constant or Centering Steering
Yellow	Row Finder Override or Steering
Green	Scalper and/or Row Finder Lift
Orange	Strut Lift/AHC Constant
Red	Door Lift

PN: 302231

DECALS

ITEM	PART NO.	DESCRIPTION	QTY
1	9971013	DECAL-GUARD MISSING	1
2	303263	DECAL-DANGER MOVING PARTS	1
3	65331	DECAL-YELLOW RETROFLECTIVE	2
4	69399	DECAL-AMITY LOGO 12X24	2
5	69400	DECAL-3300 6X12 (6R22,4R30)	2
	69402	DECAL-3500 6X12 (8R22, 6R30)	
	69403	DECAL-3600 6X12 (9R)	
	69404	DECAL-3700 6X12 (12R22, 8R30)	
	305692	DECAL-3750 6X12	
6	69406	DECAL-LH STRIPE	1
7	69408	DECAL-RH STRIPE	1
8	69405	DECAL-LH CURVE	1
9	69407	DECAL-RH CURVE	1
10	302231	DECAL - HYD LABEL: 00 SERIES HOSE COLORS	1
11	303804	DECAL -PROUDLY MADE AT AMITY	1

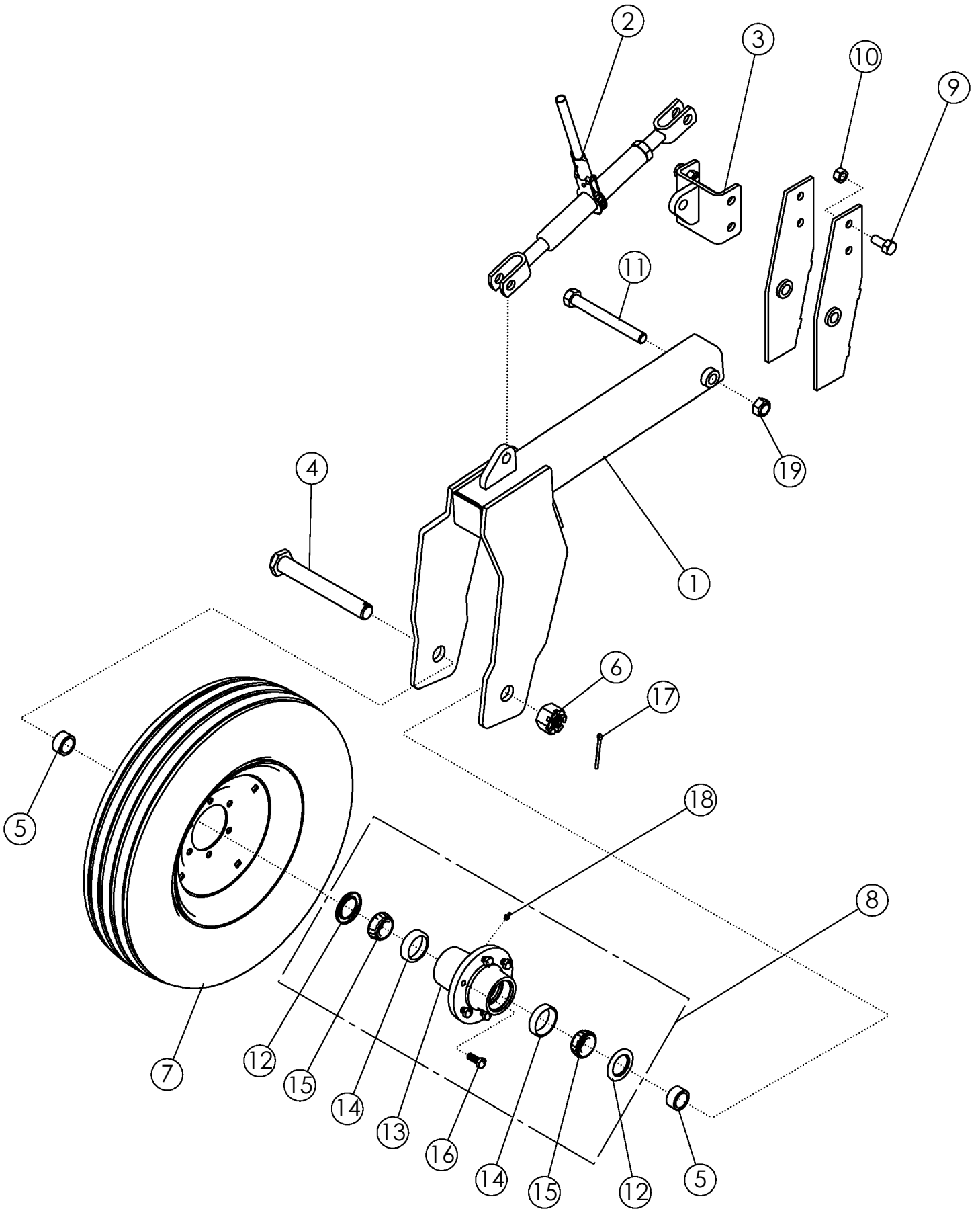

FRONT STABILIZER STRUT (OPTIONAL)			
ITEM	PART NO.	DESCRIPTION	QTY
1	306045	WLDMT-STABILIZER STRUT '00	1
2	52407	RATCHET JACK-PAINTED	1
	307307	CYLINDER 2 X 8 CUSTOM SEAL	1
	307565	KT-SEAL FOR 307307	AR
3	68468	WLDMT-LUG MOUNT	1
4	306048	WLDMT-STABILIZER SPINDLE ZP	1
5	306054	SPACER-SPINDLE ZP	2
6	306052	NUT-HEX: SLOT 1.500 NF GR2 ZP	1
7	68915	TIRE-MOUNTED: 6.50-16 6 PLY	1
8	306051	HUB-6 BOLT COMPLETE	1
9	62412	BOLT-HEX: .75 X 1.75 NC GR5 ZP	4
10	1017000	NUT-TOPLOCK: .75 NC GR5 ZP	4
11	1030866	BOLT-HEX: 1.00 X 9.00 NC GR8 ZP	1
12	306059*	SEAL-OIL CR	2
13	306061*	HUB-STABILIZER 5000LB	1
14	306063*	BEARING-CUP	2
15	306062*	BEARING-CONE 1.500 BORE	2
16	68931*	BOLT-WHEEL LUG .562-18UNF X 1.75	6
17	306034	PIN-COTTER: .25 X 3.00 ZP	1
18	1011748*	ZERK-GREASE: .25 UNF STRAIGHT	1
19	1016969	NUT-TOPLOCK: 1.00 NC GR5 ZP	1

* Items are included in Item 8

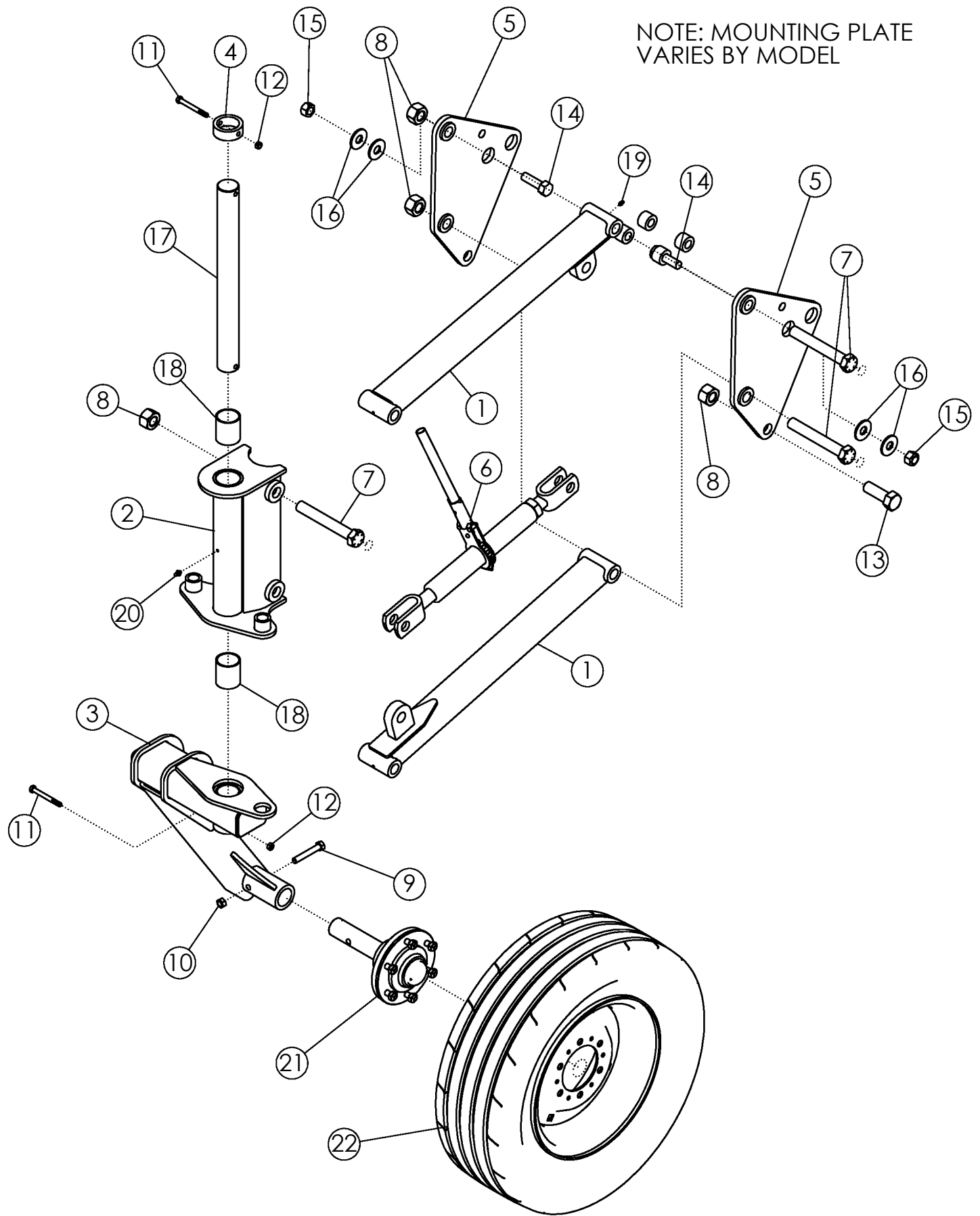

SINGLE ARM STABILIZER WHEEL

ITEM	PART NO.	DESCRIPTION	QTY
1	306675	WELDT-LINK ARM	2
2	306670	WELDT-ROTATION PIVOT	1
3	306781	CASTER ARM W/ BUSHING RH	1
	307169	CASTER ARM W/ BUSHING LH (NOT SHOWN)	
4	306692	TUBE-CAP	1
5	306689	WLDMT-STAB WHL EXT (50 SERIES)	2
	306757	WLDMT-STAB WHL EXT (00 SERIES)	2
6	52407	RATCHET JACK-PAINTED	1
	307307	CYLINDER 2 X 8 CUSTOM SEAL	1
	307565	KT-SEAL FOR 307307	AR
7	1018839	BOLT-HEX: 1.0 x 7.00 NC GR8 ZP	4
8	1016970	NUT-TOPLOCK: 1.00 NC GR8 ZP	6
9	1017719	BOLT-HEX: .50 X 3.25 NC GR5 ZP	1
10	1027461	NUT-TOPLOCK: .50 NC GR5 ZP	1
11	58176	BOLT-HEX: .38 X 3.50 NC GR5 ZP	2
12	1016999	NUT-TOPLOCK: .38 NC GR5 ZP	2
13	1018008	BOLT-HEX: 1.0 x 3.00 NC GR8 ZP	2
14	1016598	BOLT- .75 X 2.50 NC GR5 ZP	4
15	1017000	NUT-TOPLOCK: .75 NC GR5 ZP	4
16	1030702	WASHER-FLAT .75 ZP	8
17	306673	PIN-CASTER STRUT	1
18	59204	BUSHING - BORED	2
19	1011747	ZERK-GREASE: .25 UNF 90 DEG	4
20	1011748	ZERK - GREASE .25 STRAIGHT	1
21	WR41234	1.75" HUB AND SPINDLE	1
22	307015	ASSY-WHEEL IF 210 75R15	1
	307393	WHEEL-15X6 6/6 1.12 INSET (NOT SHOWN)	1

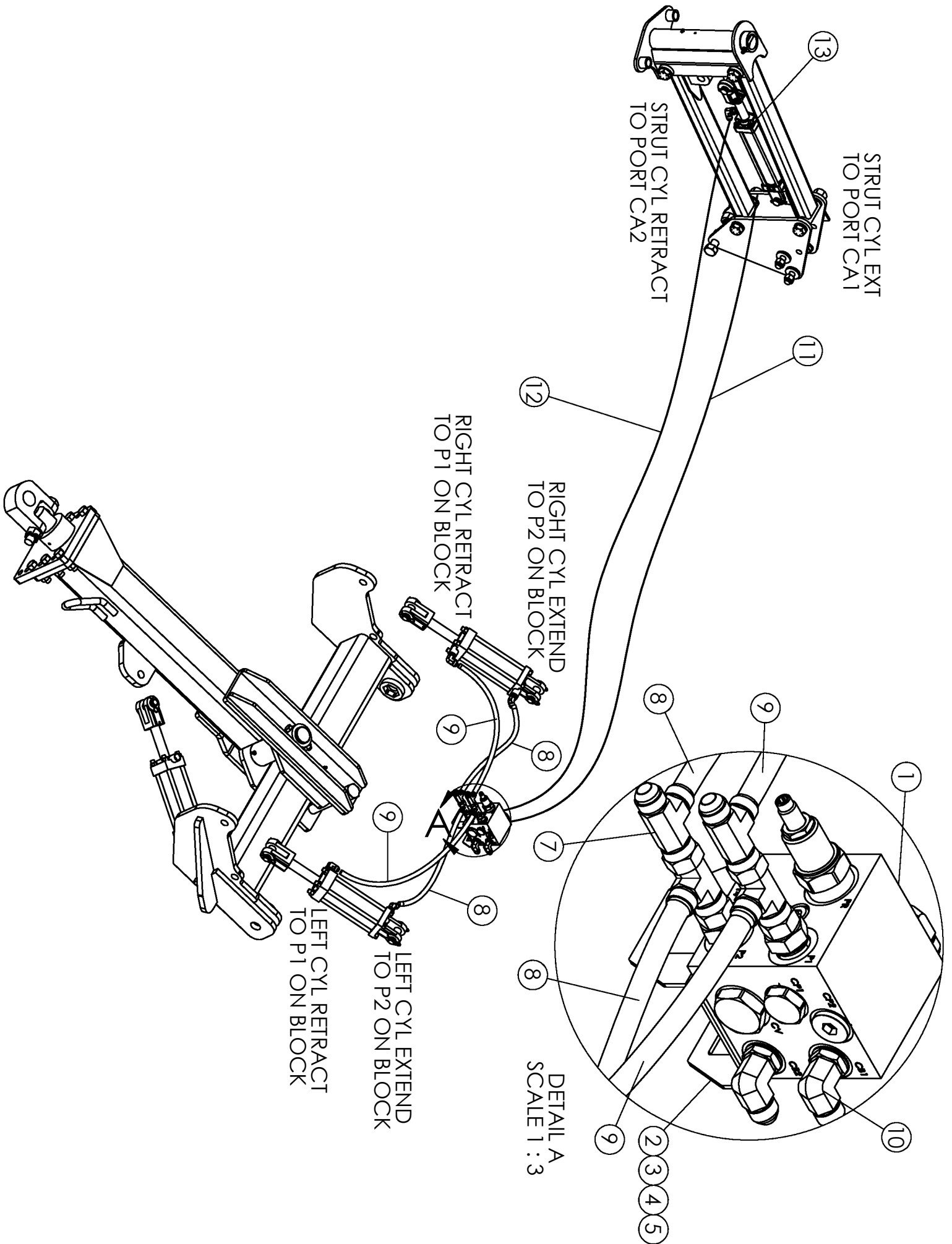

STABILIZER HYDRAULICS

ITEM	PART NO.	DESCRIPTION	QTY
1	306758	VALVE-FLOATING STABILIZER STRUTS	1
	306995	KT-SEAL FOR 306758	
2	305430	PLATE-VALVE MOUNT	1
3	1011600	BOLT-HEX: .38 X 1.00 NC GR5 ZP	2
4	1014608	WASHER-FLAT: SAE .38 ZP	2
5	1011586	WASHER-LOCK: .38 ZP	2
6	58195	FTG-ADAPTER: 10MB-8MJ	2
7	63015	FTG-TEE: 8MJ-8FJX-8MJ	4
8	63900	HOSE: .50 X 028 8FJX-8FJX	2
9	57000	HOSE: .50 X 034 8FJX-8FJX	2
10	58560	FTG-ELBOW: 8MB-8MJ-90	8
11	67256	HOSE: .50 X 148 8FJX-8FJX	2
12	63668	HOSE: .50 X 160 8FJX-8FJX	2
13	307307	CYLINDER 2 X 8 CUSTOM SEAL	2
	307565	KT-SEAL FOR 307307	
ALTERNATE PLUMBING TO R/F OR SCALPER LIFT (NEXT PAGE)			
14	300034	HOSE: .50 X 084 8FJX-8MB	2
15	1018744	HOSE: .50 X 130 8FJX-8FJX	2
16	57668	FTG-ELBOW: 8MJ-8FJX-90	2

*HITCH ROUTING WILL REMAIN UNTOUCHED FROM INITIAL SETUP AND REMOVE THE SECOND TEE ON EACH P1 AND P2.

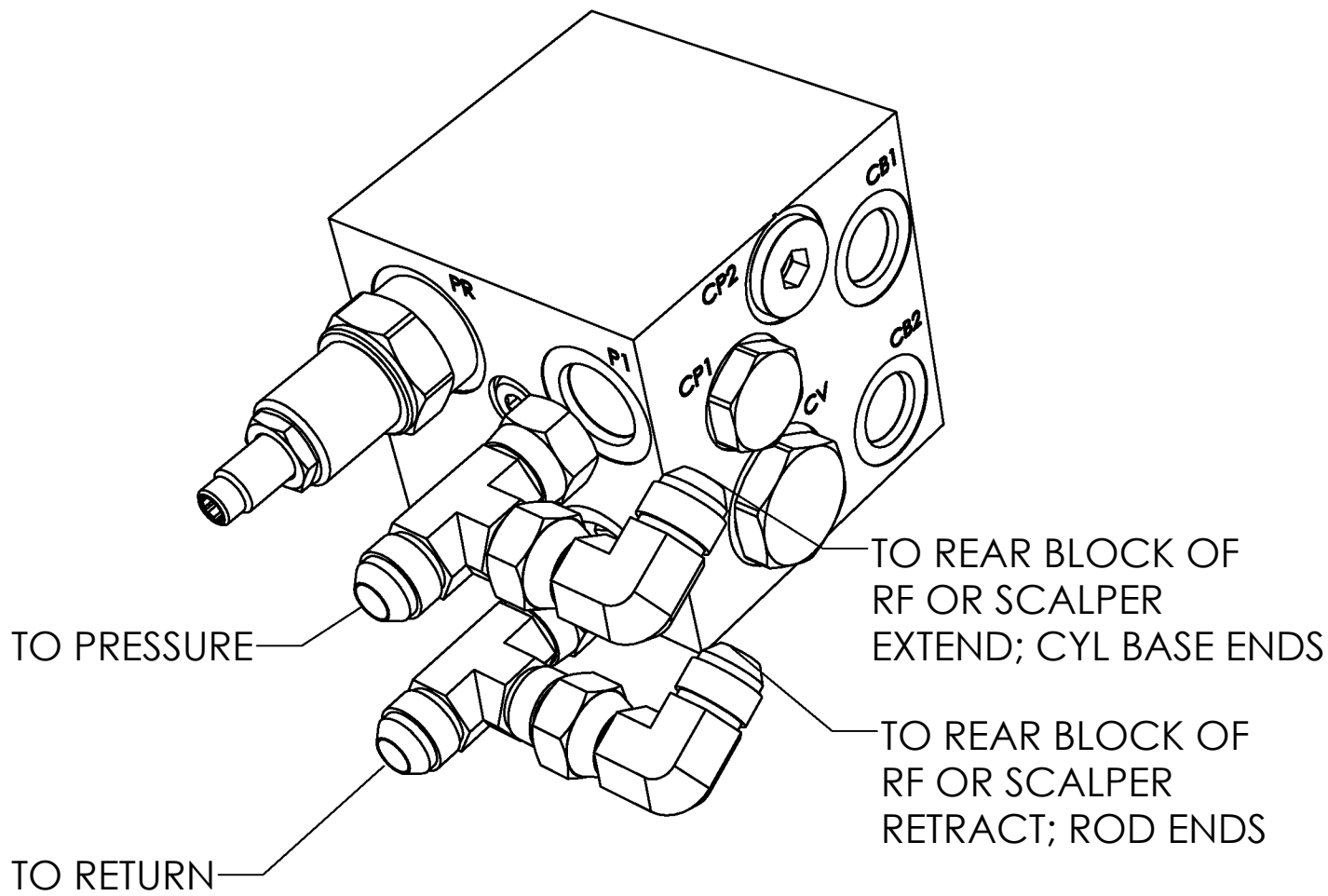

THIS PAGE IS INTENTIONALLY LEFT BLANK

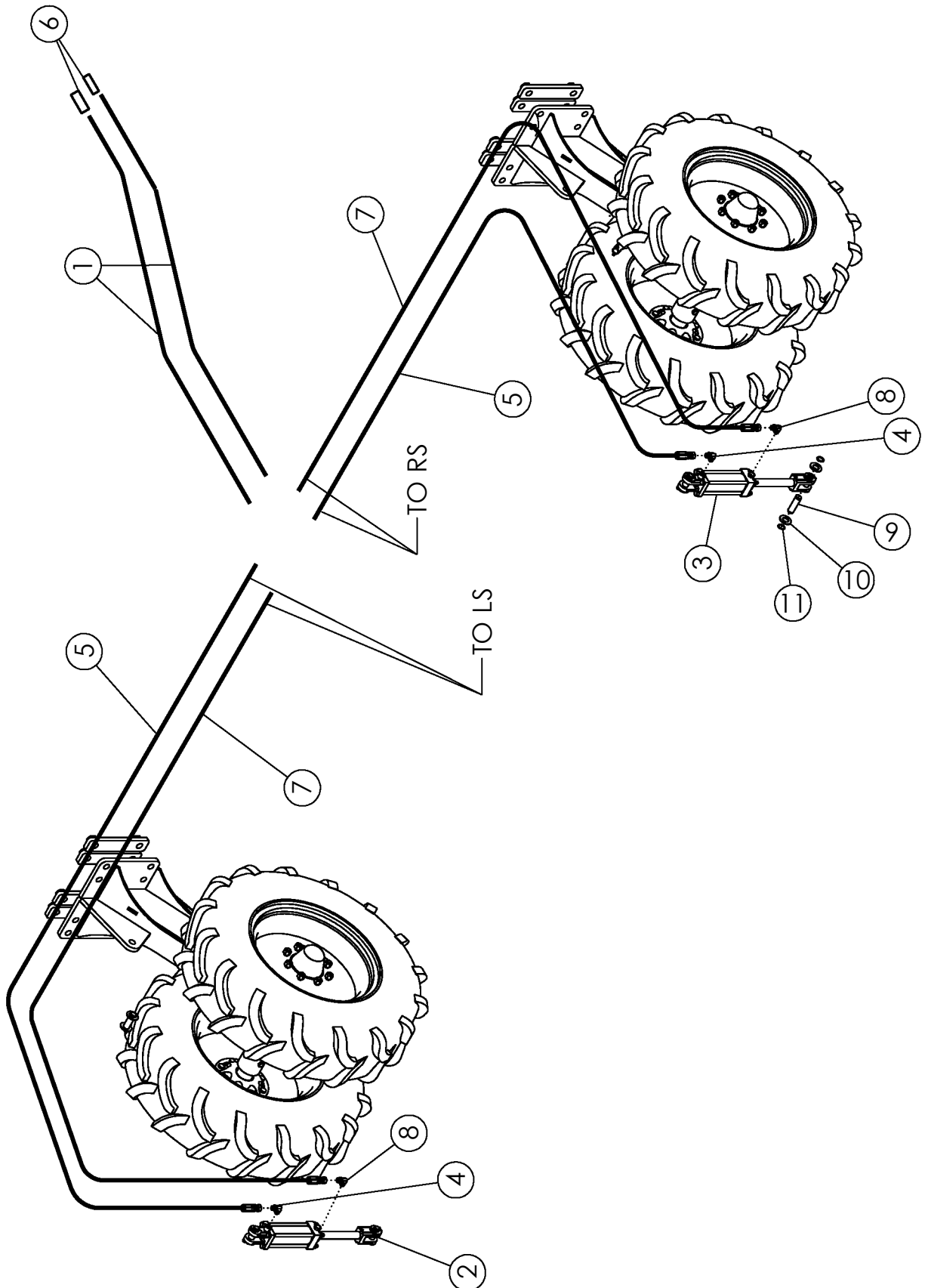

REAR STRUT HYDRUALICS

ITEM	PART NO.	DESCRIPTION	QTY
1	305684	HOSE: .50 X 215 8FJX-8MB	2
2	63500	CYLINDER-REPHASING 3.25 X 8.00	1
	66083	SEAL KIT FOR 63500	
3	63499	CYLINDER-REPHASING 3.00 X 8.00	1
	301314	SEAL KIT FOR 63499	
4	58560	FTG-ELBOW: 8MB-8MJ-90	2
5	305577	HOSE: .38 X 116 8FJX-8FJX	2
6	36290	PIONEER TIP 8010-15P (#8 ORB)	2
7	305674	HOSE: .38 X 106 8FJX-8FJX	2
8	305402	FTG-ELBOW: 8MB-8MJ-90L	2
9	311191	PIN-CYLINDER 1.00 X 3.45 W/ GROOVE ZP	4
10	1016663	WASHER-FLAT: SAE 1.00 ZP	8
11	36430	RING-RETAINING 1.000 ZP	8

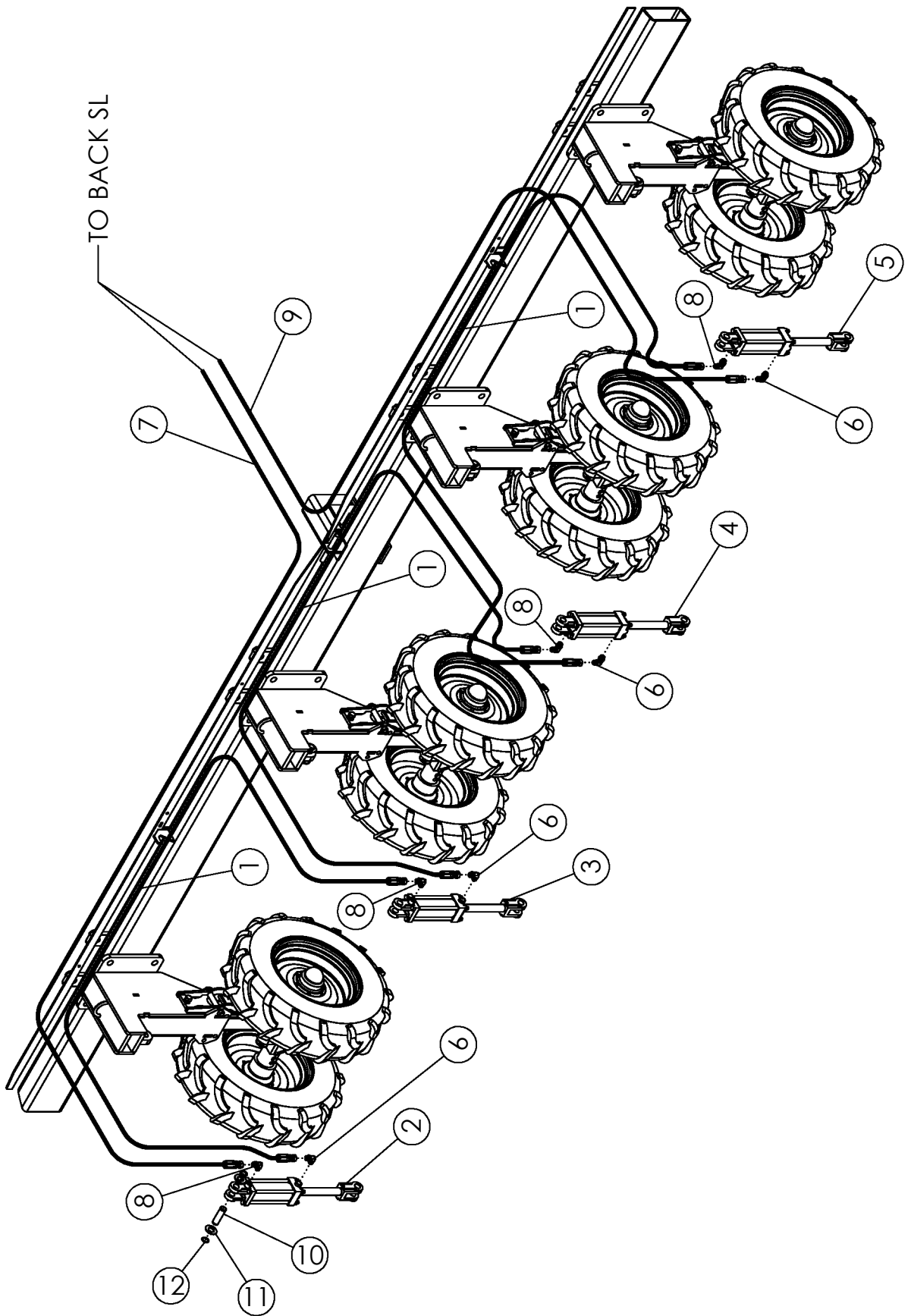

REAR STRUT HYDRAULICS - 7.6 X 15 (OPTIONAL)

ITEM	PART NO.	DESCRIPTION	QTY
1	64482	HOSE: .38 X 126 8FJX-8FJX	3
2	63500	CYLINDER-HYDRAULIC 3.25 X 8" 3000	1
	66083	SEAL KIT FOR 63500	
3	63499	CYLINDER-HYDRAULIC 3 X 8" 3000	1
	301314	SEAL KIT FOR 63499	
4	63498	CYLINDER-HYDRAULIC 2.75 X 8" 3000	1
	64424	SEAL KIT FOR 63498	
5	63497	CYLINDER-HYDRAULIC 2.50 X 8" 3000	1
	64423	SEAL KIT FOR 63497	
6	58560	FTG-ELBOW: 8MB-8MJ-90	8
7	305674	HOSE: .38 X 106 8FJX-8FJX	1
8	305402	FTG-ELBOW: 8MB-8MJ-90L	2
9	305577	HOSE: .38 X 116 8FJX-8FJX	1
10	311191	PIN-CYLINDER 1.00 X 3.45 W/ GROOVE ZP	8
11	1016663	WASHER-FLAT: SAE 1.00 ZP	16
12	36430	RING-RETAINING 1.000 ZP	16

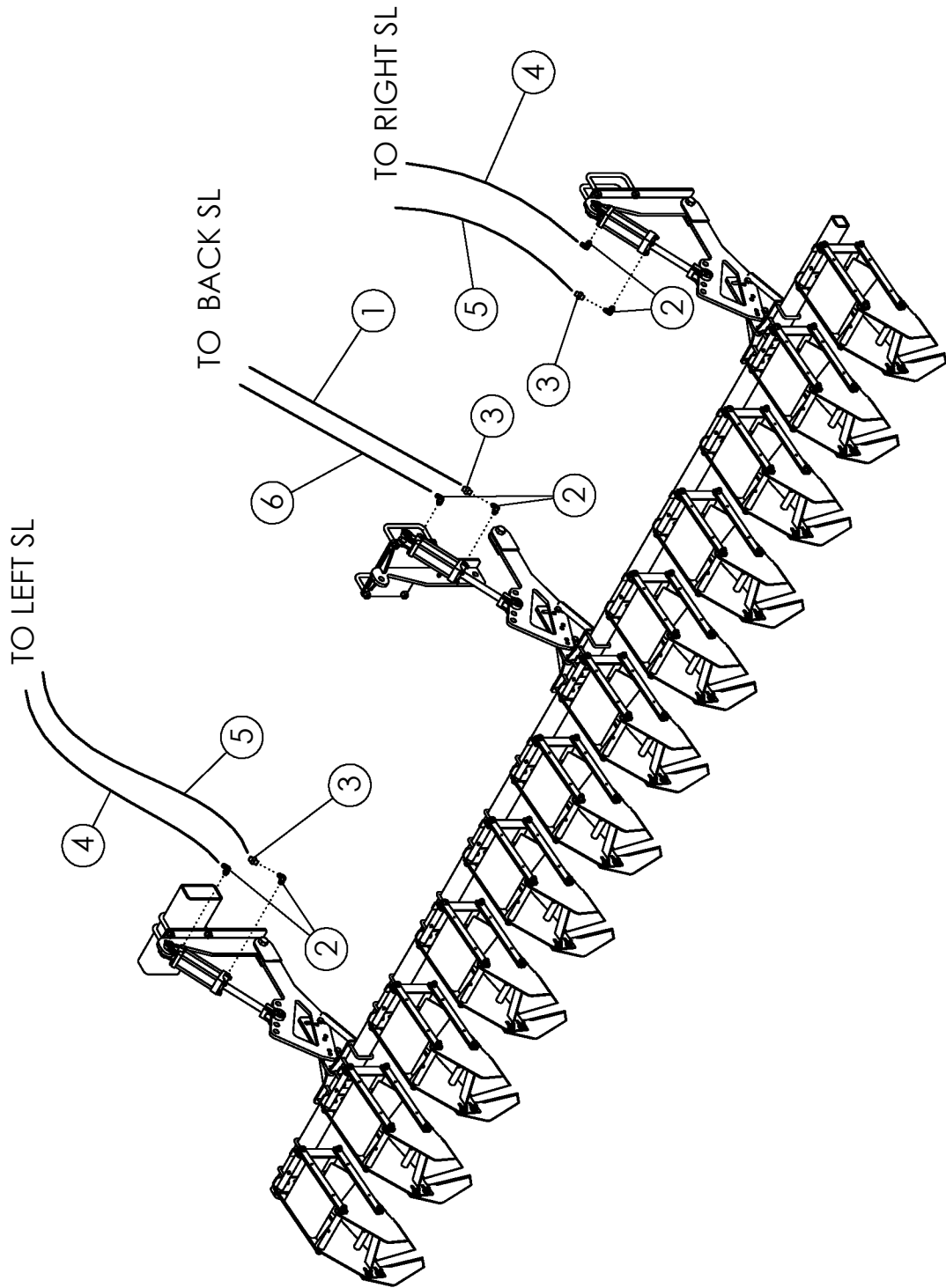

SCALPER HYDRAULICS

ITEM	PART NO.	DESCRIPTION	QTY
1	305668	HOSE: .38 X 027 8FJX-8FJX	1
2	58560	FTG-ELBOW: 8MB-8MJ-90	6
3	1019844	FTG-RESTRICTOR 8FJ-8MJ	3
4	69078	HOSE: .38 X 132 8FJX-8FJX	2
5	69079	HOSE: .38 X 144 8FJX-8FJX	2
6	62998	HOSE: .38 X 020 8FJX-8FJX	1

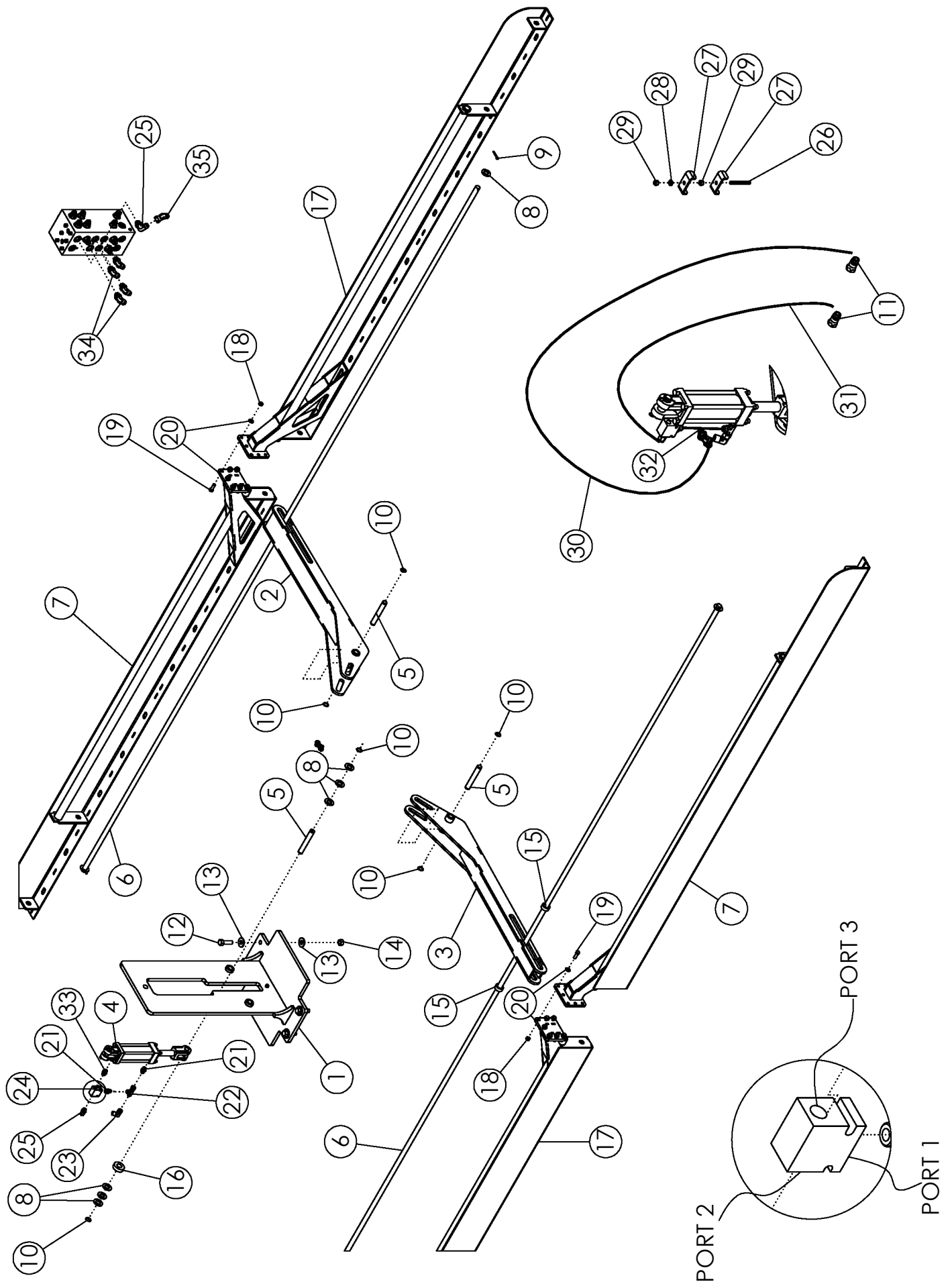

ASSY-TOP DOOR LIFT - 12 ROW

ITEM	PART NO.	DESCRIPTION	QTY
1	305357	WLDMT-DEF TOP DOOR TOWER	1
2	305361	WLDMT-DEF TOP DOOR ARMS REAR	1
3	305364	WLDMT-DEF TOP DOOR ARMS FRONT	1
4	58890	CYLINDER HYDRAULIC 3 X 8	1
	301314	SEAL KIT 3 X 8 3000PSI UNIVERSAL	
5	305380	PIN-DEF TOP DOOR TOWER	3
6	305378	ROD-DEF TOP DOOR ROLLER SHAFT 12R	2
7	305373	WLDMT-DEF TOP DOOR WING A	2
8	1016663	WASHER-FLAT: SAE 1.00 ZP	10
9	1016944	PIN-COTTER: .25 X 2.00 ZP	4
10	36430	RING-RETAINING 1.000 ZP	6
11	36290	PIONEER TIP 8010-15P (#8 ORB)	2
12	1016598	BOLT- .75 X 2.50 NC GR5 ZP	4
13	1030702	WASHER-FLAT .75 ZP	8
14	1017000	NUT-TOPLOCK: .75 NC GR5 ZP	4
15	305379	BUSHING-DEF TOP DOOR WING FRONT ZP	2
16	305381	PLATE-CYLINDER ROLLER ZP	1
17	305375	WLDMT-DEF TOP DOOR WING B	2
18	1027461	NUT-TOPLOCK: .50 NC GR5 ZP	14
19	1011607	BOLT-HEX: .50 X 1.50 NC GR5 ZP	14
20	1032505	WASHER-FLAT: SAE .50 GR8 ZP	28
21	56226	FTG-ADAPTER: 8MB-8MJ	2
22	63015	FTG-TEE: 8MJ-8FJX-8MJ	1
23	57668	FTG-ELBOW: 8MJ-8FJX 90	2
24	305404	VALVE-CHECK SINGLE PILOT OPERATED	1
25	58560	FTG-ELBOW: 8MB-8MJ-90	2
26	65379	STUD-.375 X 3.00 UNC ZP	2
27	50714	CLAMP .50 ZP	4
28	1011586	WASHER-LOCK: .38 ZP	2
29	1011576	NUT-HEX: .38 NC GR2 ZP	4
30	305394	HOSE: .38 X 176 8MB-8FJX	1
31	305395	HOSE: .38 X 186 8MB-8FJX	1
32	305345	HOSE: .38 X 8.25 8FJX-8FJX	1
33	305343	FTG-ADAPTER: 8MB-8MB	1
34	58515	FTG-ELBOW: 8MB-8MJ-45	4
35	57663	FTG-ELBOW: 8MJ-8FJX-45	1

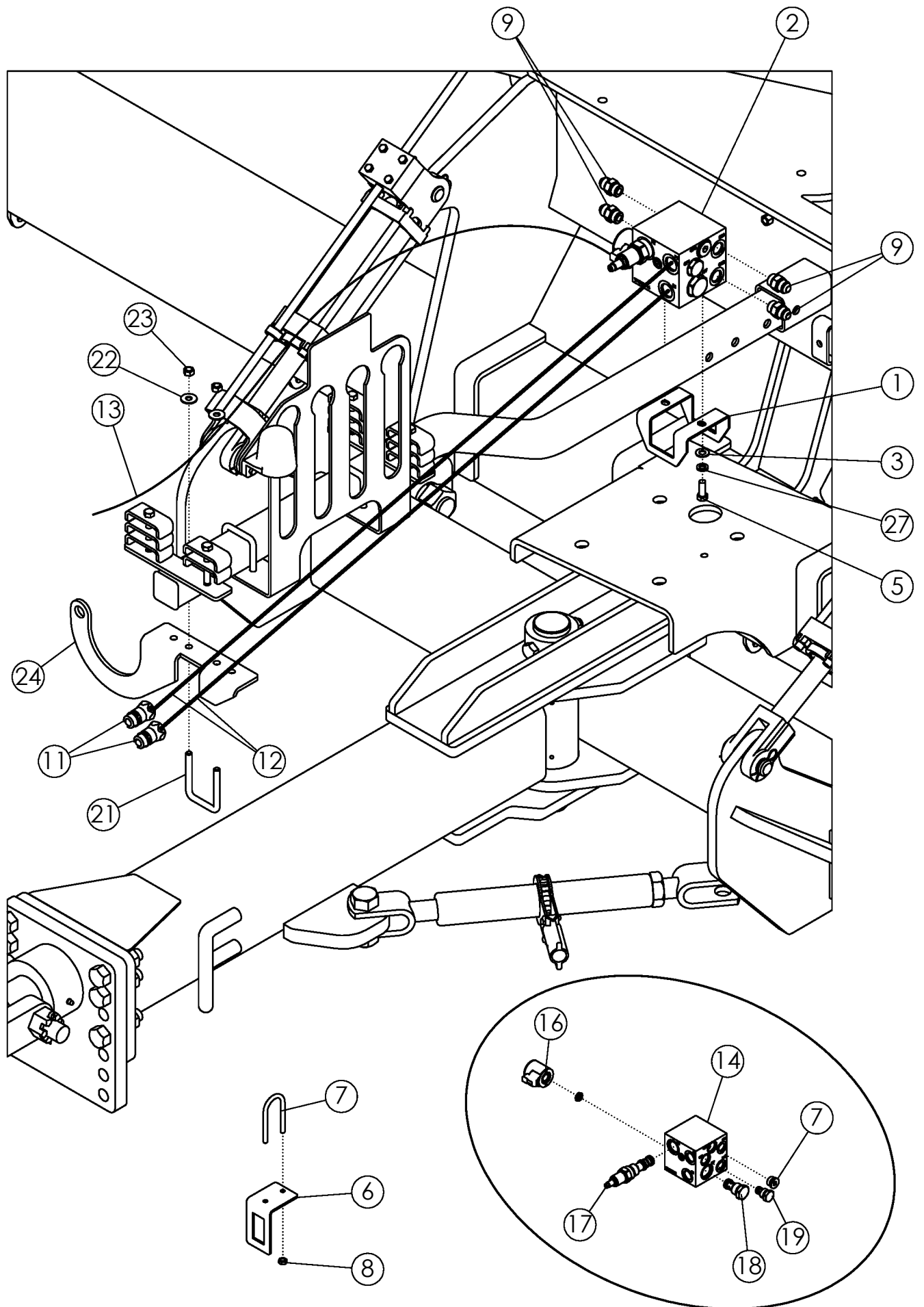

FLOATING HITCH KIT

ITEM	PART NO.	DESCRIPTION	QTY
1	305430	PLATE-VALVE MOUNT	1
2	305791	FLOATING HITCH VALVE	1
3	1014608	WASHER-FLT: SAE .38 ZP	2
4	1011586	WASHER-LOCK: .38 ZP	2
5	1011600	BOLT-HEX: .38 X 1.00 NC GR5 ZP	2
6	305792	PLATE-SWITCH BRACKET	1
7	340068	U-BOLT: RND .25 X 1.25 X 2.25 ZP	1
8	1030946	NUT-TOPLOCK: .25 NC GR5 ZP	1
9	56226	FTG-ADAPTER: 8MB-8MJ	4
10	305793	ASSY-SWITCH SPST ONE RED LIGHT (NOT SHOWN)	1
11	36290	PIONEER TIP 8010-16P (#10 ORB)	2
12	305431	HOSE: .63 X 108 10MB-10MB	2
13	305440	HARNESS-FLOATING HITCH	1
21	33162	U-BOLT: .375 X 3.00 X 2.00 X 3.00	1
22	1011828	WASHER-FLAT: .38 ZP	2
23	1016999	NUT-TOPLOCK: .38 NC GR5 ZP	2
24	303417	PLATE-PTO STORAGE	1
INCLUDED IN ITEM 2 305791			
14	306714	BLOCK-RAISE/LOWER HITCH	1
15	306715	VALVE-#12 SOLENOID, NC POPPET	1
16	306716	E-COIL-#10, 12 VDC, DEUTSCH DT04-2P, ZENER	1
17	306717	VALVE-#12 PRESSURE REDUCING RELIEVING, PILC	1
18	306718	VALVE-#12 CHECK 5 PSI	1
	306990	KT-SEAL FOR 306718	
19	306719	PLUG-#10 CAVITY	1
	306991	KT-SEAL FOR 306719	
20	306720	PLUG-SAE-10 HOLLOW HEX	1

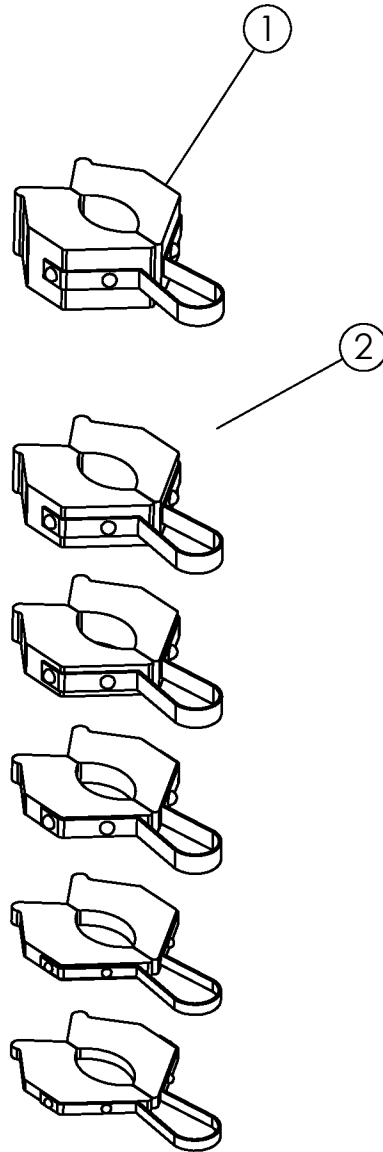
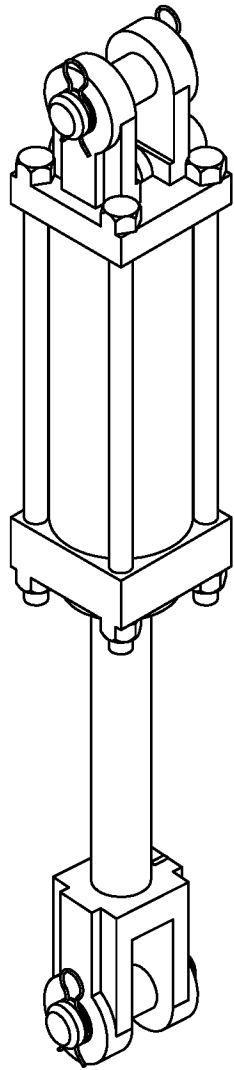

CYLINDER STOP KIT #51497 (OPTIONAL)

ITEM	PART NO.	DESCRIPTION	QTY
1	54004	STOP-CYLINDER 1.5" (SILVER)	1
2	52320	CYLINDER STOP A-KT (.25 THRU 1.00)	1

TOP VIEW

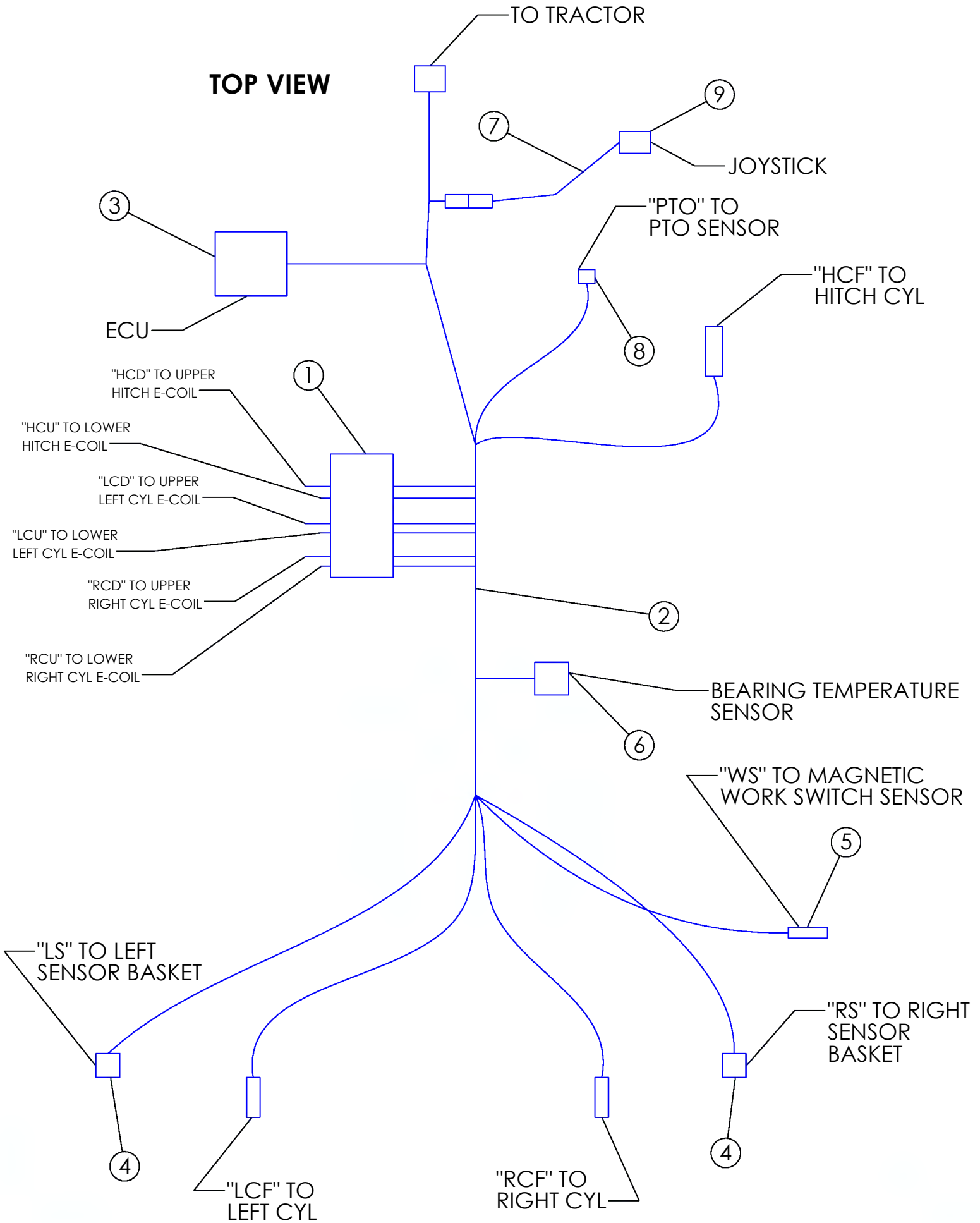

AHC ISOBUS - ELECTRICAL COMPONENTS

ITEM	PART NO.	DESCRIPTION	QTY
1	305939	VALVE-3 BANK AHC	1
	306996	KT-SEAL FOR 305939	
2	307253	HARNESS-AHC ISOBUS MAIN	1
3	307250	ASSY-AHC ISOBUS CONTROLLER	1
4	73492	SENSOR-ROTARY POSITION	2
5	306862	ASSY-MAGNETIC PROXIMITY SENSOR AHC	1
6	307255	SENSOR-AHC TEMPERATURE SENSOR	1
7	303444	HARNESS-ADC ISOBUS JOYSTICK EXT	1
8	301014	SENSOR-PTO ADC	1
9	301151	ASSY-JOYSTICK & ENCLOSURE	1

TOP VIEW

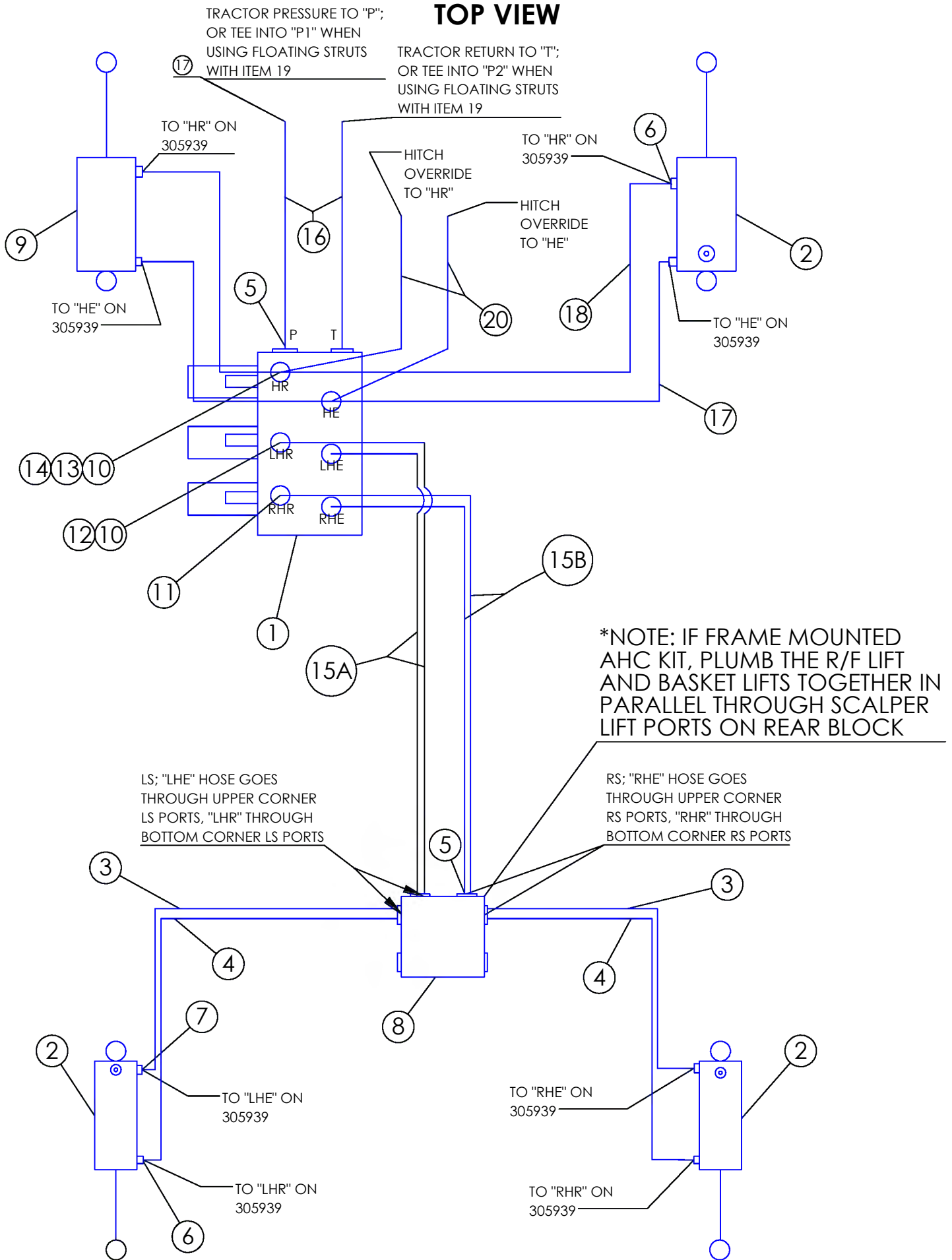

AHC - HYDRAULIC COMPONENTS

ITEM	PART NO.	DESCRIPTION	QTY
1	305939	VALVE-3 BANK AHC	1
	306878	#10 SPOOL, 4W3P, MOTOR SPOOL	3
	36449	COIL-SDD DOWNPRESSURE	6
	306880	#10 COIL SPACER	3
	306881	VALVE-COUNTER BALANCE 5:1 300	3
	306882	#10 CHECK VALVE 5 PSI	1
	306883	#10 PILOT CHECK 4:1 RATIO 30 PSI	1
	306979	SEAL KIT-CARTRIDGE FOR 305939	1
	306996	KT-SEAL FOR 305939	1
	306893	BOLT-HEX: .31 X 5.50 NC GR5 ZP	2
	1030700	NUT-TOPLOCK: .31 NC GR5 ZP	2
2	307298	CYLINDER-HYD 3 X 8-3000-0" AHC (REPLACEABLE SENSOR)	3
3	305674	HOSE: .38 X 106 8FJX-8FJX	2
4	305577	HOSE: .38 X 116 8FJX-8FJX	2
5	56226	FTG-ADAPTER: 8MB-8MJ	10
	58560	FTG-ELBOW: 8MB-8MJ-90 (FOR FLOATING STRUTS)	2
6	58560	FTG-ELBOW: 8MB-8MJ-90	6
7	305402	FTG-ELBOW: 8MB-8MJ-90L	2
8	305960	HYDRAULIC BLOCK AHC	1
9	58891	CYLINDER-HYDRAULIC 4 X 8" 3000	1
10	62024	FTG-ADAPTER: 6MB-8MJ	4
11	1019756	FTG-ELBOW: 6MB-8MJ-90	2
12	57668	FTG-ELBOW: 8MJ-8FJX-90	2
13	63015	FTG-TEE: 8MJ-8FJX-8MJ	2
14	66603	FTG-TEE: 8MJ-8MJ-8FJX	2
15A	36009	HOSE: .50 X 120" 8FJX-8FJX	2
15B	66597	HOSE: .50 X 114" 8FJX-8FJX	2
16	66609	HOSE: .50 X 96" 8MB-8FJX	2
	300034	HOSE: .50 X 84" 8MB-8FJX (FOR FLOATING STRUTS)	2
17	66605	HOSE: .50 X 32" 8FJX-8FJX	2
18	301105	HOSE: .50 X 42" 8FJX-8FJX	2

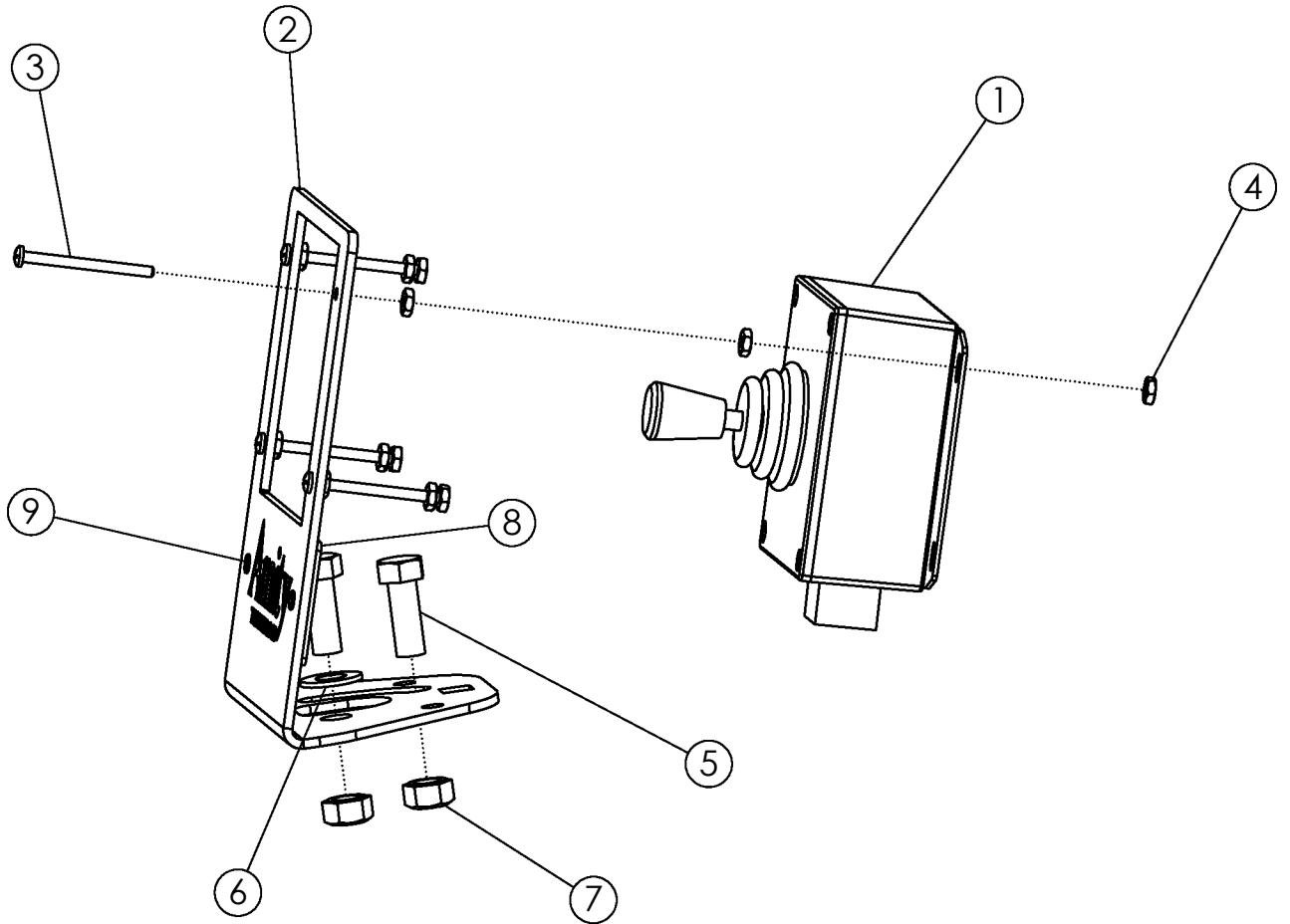

KT- JOYSTICK WITH MOUNT #303448

ITEM	PART NO.	DESCRIPTION	QTY
1	301151	ASSY-JOYSTICK & ENCLOSURE	1
2	303451	PLATE-JOYSTICK MOUNT	1
3	1019992	SCREWP-H: #6 X 1.75 NC GR5 ZP	4
4	1040448	#6 NUT	12
5	1011600	BOLT-HEX: .38 X 1.00 NC GR5 ZP	2
6	1014608	WASHER-FLAT: SAE .38 ZP	1
7	1016999	NUT-TOPLOCK: .38 NC GR5 ZP	2
8	311514	PLATE-JOYSTICK LOGO	1
9	59882	RIVET-POP: .13 X .31 ZP	2

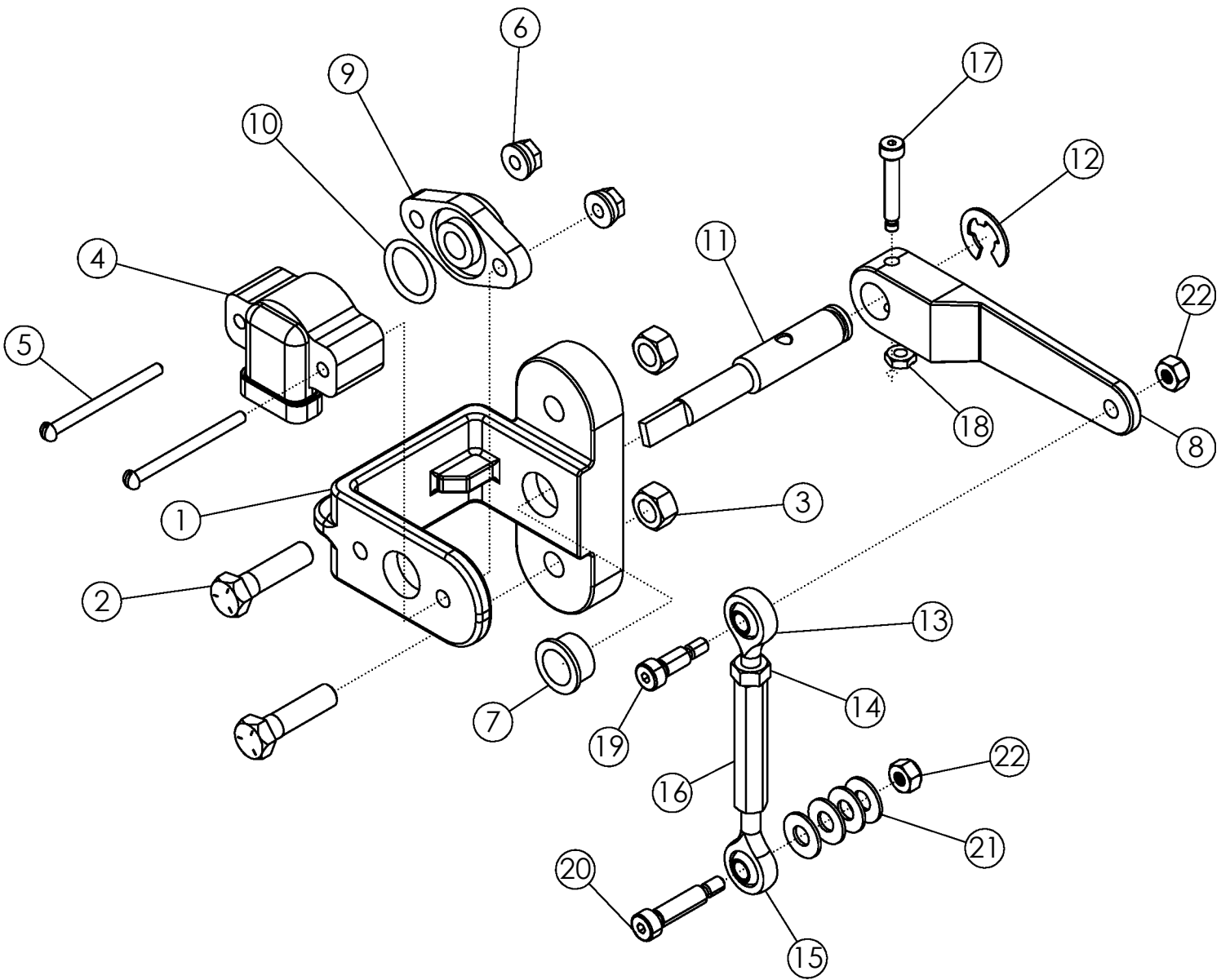

KT-AHC BASKET SENSOR ASSY (307319)

ITEM	PART NO.	DESCRIPTION	QTY
1	306821	SENSOR BRACKET-AHC	1
2	1032277	BOLT-HEX: .31 X 1.25 NC GR5 ZP	2
3	1030700	NUT-TOPLOCK: .31 NC GR5 ZP	2
4	73492	SENSOR-ROTARY POSITION	1
5	306836	SCREW-MACH RND: #10-24 X 2.0"	2
6	1026591	NUT-K-LOCK: #10-24 NC GR2 ZP	2
7	306822	GROMMET-AHC SHAFT	1
8	306823	LEVER-DLS	1
9	306825	SUPPORT - SHAFT AHC	1
10	306826	O-RING	1
11	306827	SHAFT-AHC ZP	1
12	306895	SNAP-RING: FOR 1/2" OD - 0.46 ID X .035"	1
13	306828	BALL JOINT ROD END 1/4"-28 RH	1
14	1011579	NUT-HEX: .25 NF GR2 ZP	1
15	306829	BALL JOINT ROD END 1/4"-28 LH	1
16	306830	TURNBUCKLE 1/4"-28	1
17	306831	BOLT-SHOULDER: 3/16" X 1.0" SHLD LNTH X #8-32 THRD	1
18	307497	NUT-NYLOCK: #8-32 GR2 ZP THIN	1
19	306832	BOLT-SHOULDER: 1/4" X 1/2" SHLD LNTH X #10-24 THRD	1
20	306833	BOLT-SHOULDER: 1/4" X 1.0" SHLD LNTH X #10-24 THRD	1
21	65695	WASHER-FLAT: .25 SS	4
22	67079	NUT-NYLOCK: #10-24 NC GR2 ZP	2

ASSEMBLED VIEW

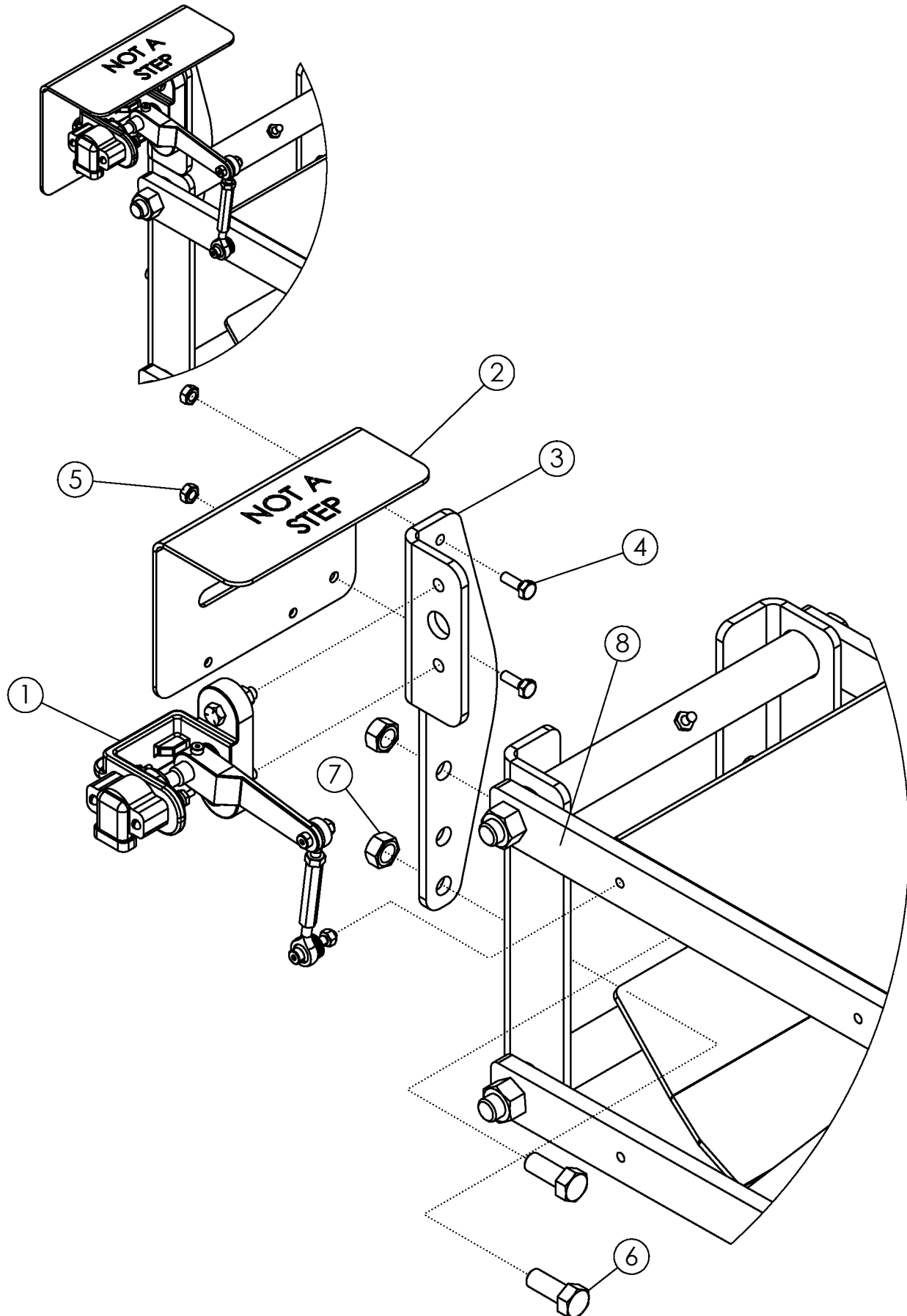

BASKET SENSOR MOUNT

ITEM	PART NO.	DESCRIPTION	QTY
1	307319	KT-AHC BASKET SENSOR ASSY	1
2	306926	PLATE-AHC SENSOR COVER	1
3	306835	PLATE-AHC SENSOR MOUNT BRACKET	1
4	1011595	BOLT-HEX: .25 X .75 NC CR5 ZP	2
5	1030946	NUT-TOPLOCK: .25 NC GR5 ZP	2
6	1011606	BOLT-HEX: .50 X 1.25 NC GR5 ZP	2
7	1027461	NUT-TOPLOCK: .50 NC GR5 ZP	2
8	306848	BAR-PARALLEL LINK AHC THREADED PC	1

FIG. 1 - PTO SENSOR MOUNT



FIG. 2 - WORKSWITCH MOUNT

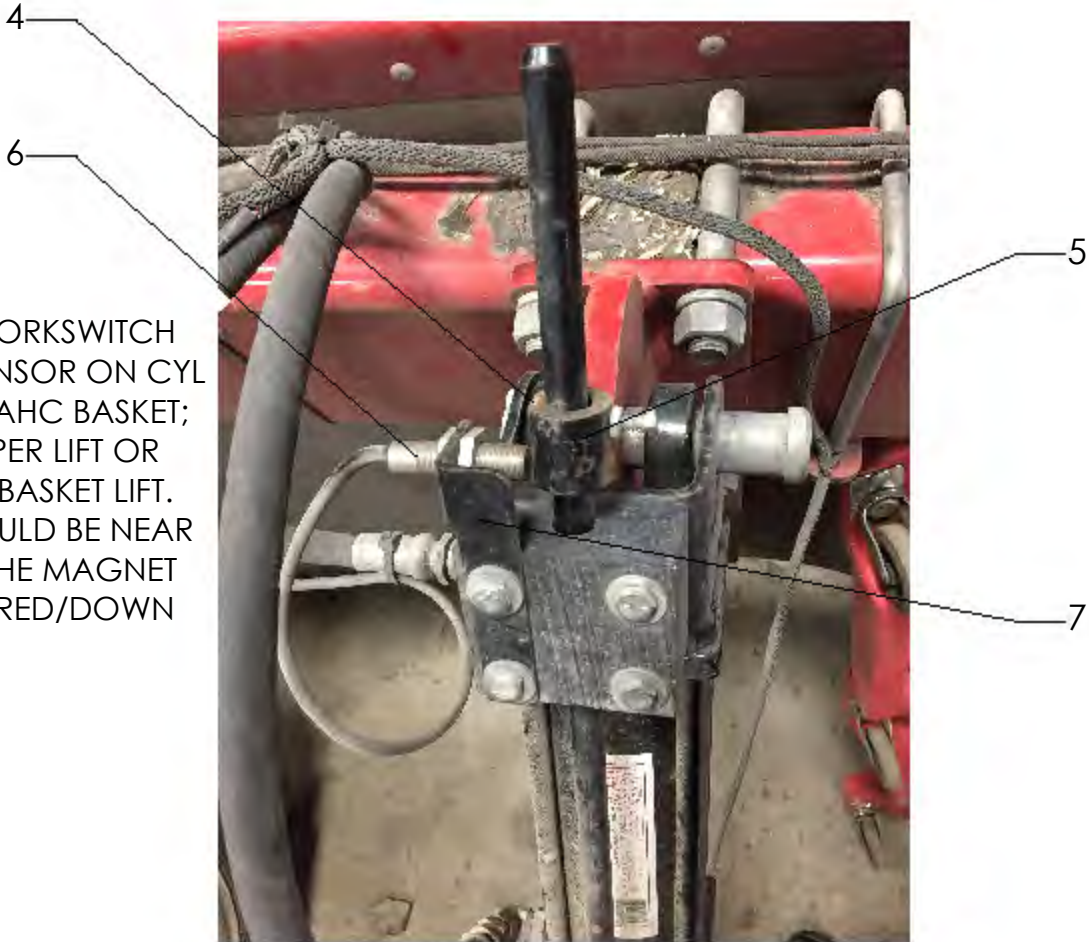

NOTE:
ASSEMBLE WORKSWITCH
TO DEPTH SENSOR ON CYL
THAT RAISES AHC BASKET;
EITHER SCALPER LIFT OR
AHC FRAME BASKET LIFT.
SENSOR SHOULD BE NEAR
TOUCHING THE MAGNET
IN THE LOWERED/DOWN
POSITION

PTO SENSOR (FIG. 1)

ITEM	PART NO.	DESCRIPTION	QTY
1	301014	SENSOR-PTO ADC	1
2	64388	WLDMT-SPLIT COLLAR 1.75"	1
3	305958	PLATE-PTO SENSOR MOUNT	1

MAGNETIC WORKSWITCH (FIG.2)

4	305959	MAGNET-WORK SWITCH AHC	1
5	305595	TUBE-AHC MAGNET HOLDER ZP	1
6	306862	ASSY-MAGNETIC PROXIMITY SENSOR AHC	1
7	306896	PLATE-MAGNETIC SENSOR MNT	1

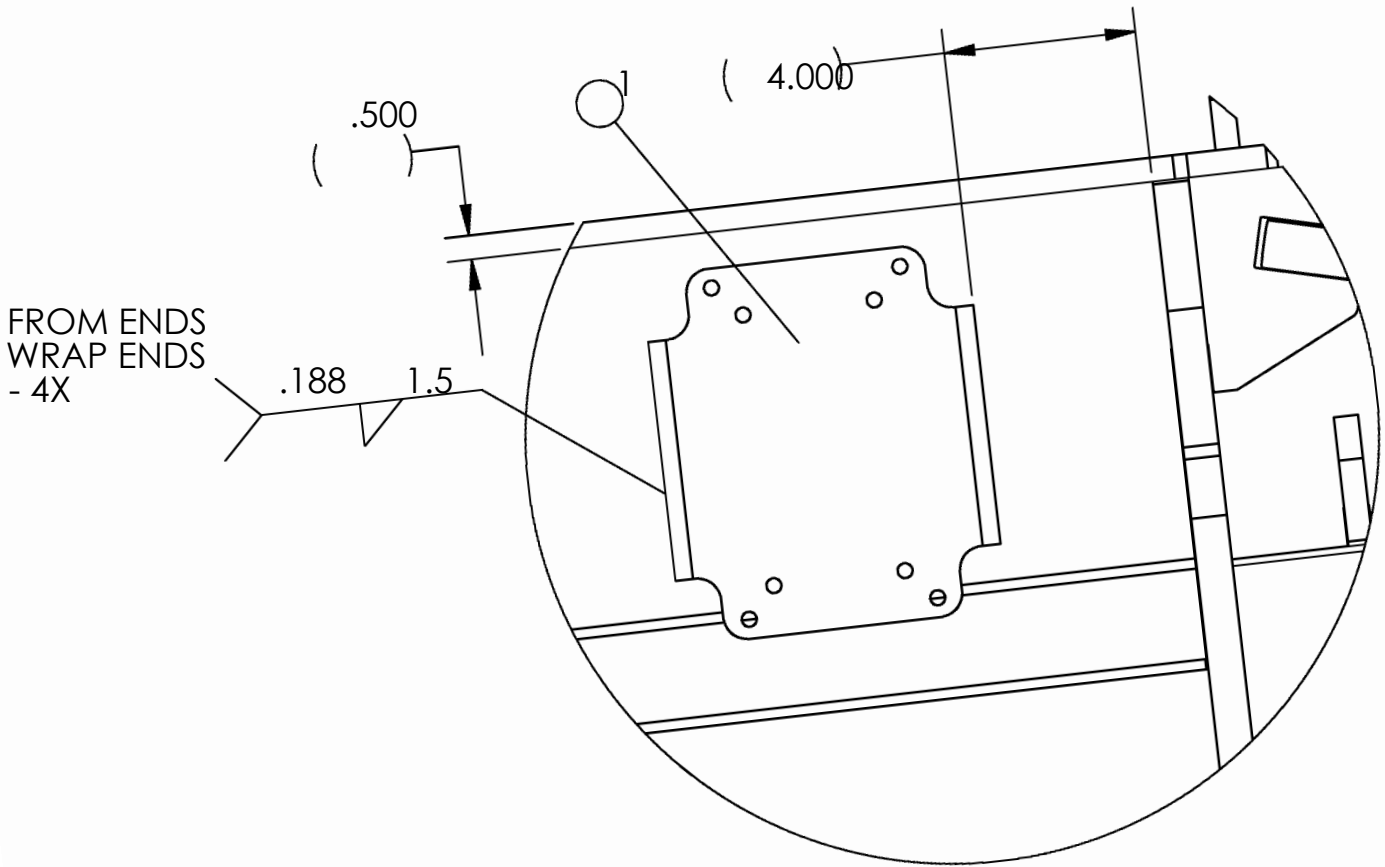
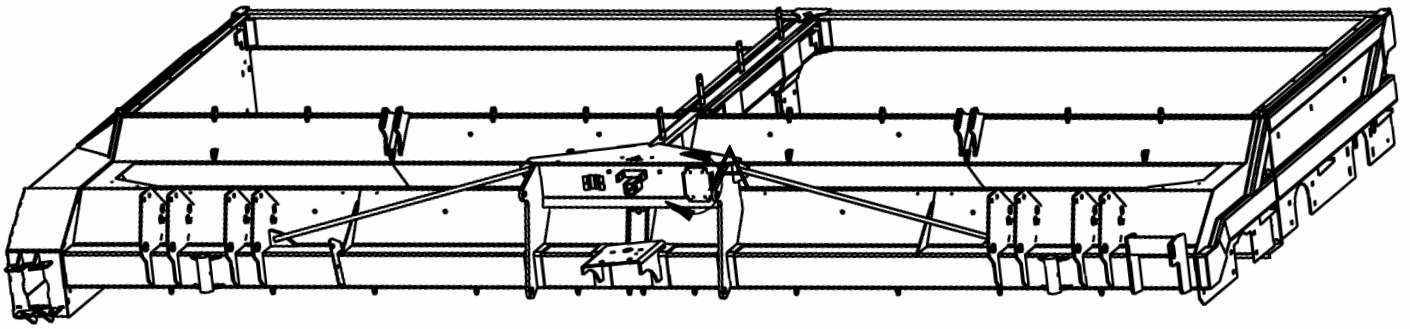

ECU MOUNT

ITEM	PART NO.	DESCRIPTION	QTY
1	306894	PLATE-ECU MOUNT HOLDER	1

REFERENCE PICTURES



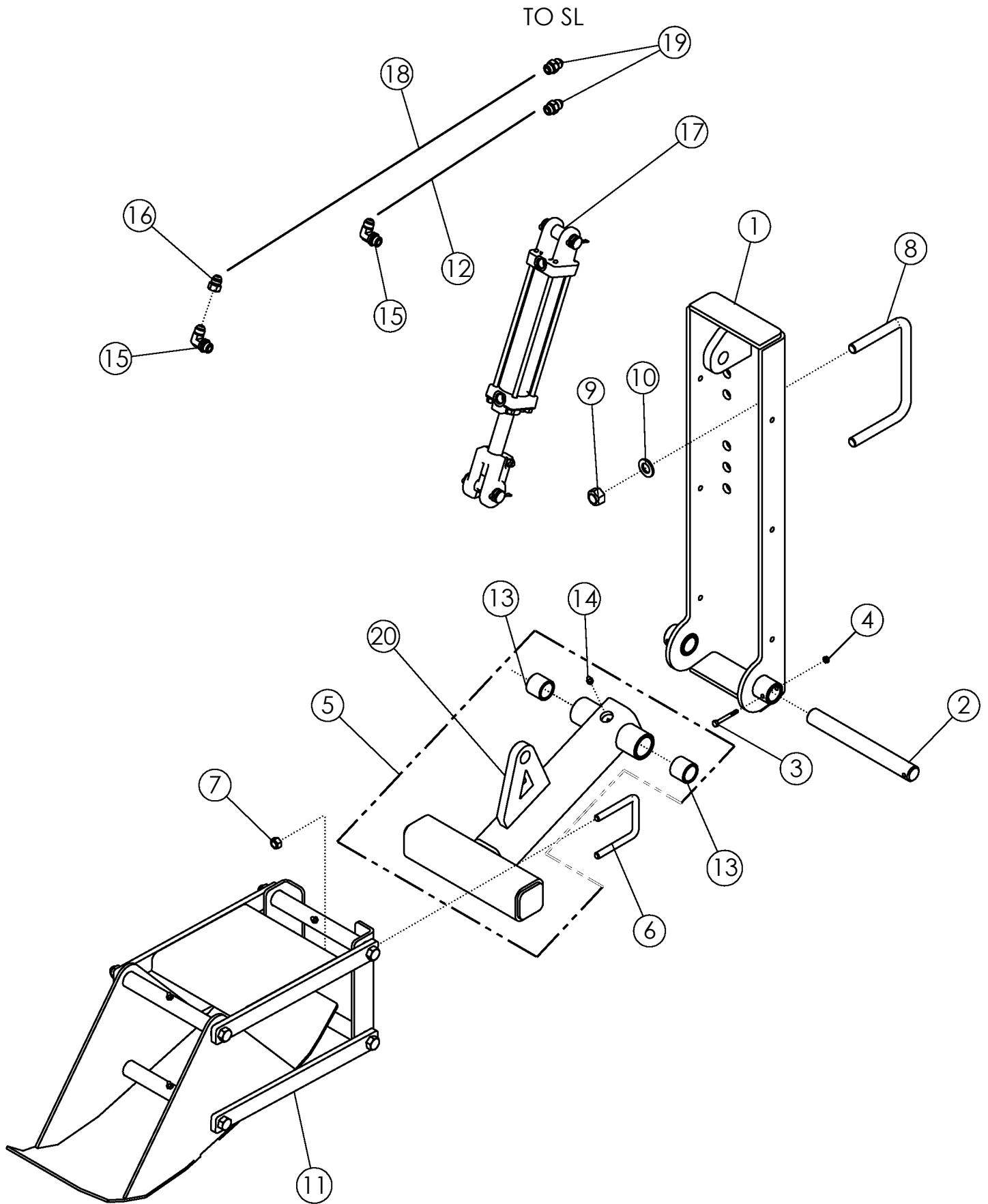

ASSY - AHC FRAME MOUNT

ITEM	PART NO.	DESCRIPTION	QTY
1	305057	WLDMT-ROW FINDER MOUNT UPPER	1
2	305053	SHAFT-ROW FINDER	1
3	1013942	BOLT-HEX: .25 X 2.25 NC GR5	1
4	1030946	NUT-TOPLOCK: .25 NC GR5 ZP	1
5	305933	ASSY-SENSOR MOUNT LOWER W/ BUSHINGS	1
6	69954	U-BOLT: .500 X 4.00 X 3 X 4.00	2
7	1027461	NUT-TOPLOCK: .50 NC GR5 ZP	4
8	56263	U-BOLT: .75 X 5.5 X 8 X 5.5	2
9	1017000	NUT-TOPLOCK: .75 NC GR5 ZP	4
10	1012634	WASHER-FLAT: SAE .75 ZP	4
11	306887	ASSY-AHC NO KNIFE BASKET	1
12	69079	HOSE: .38 X 144 8FJX-8FJX	1
13	56939*	BUSHING-OILITE: 1.25 X 1.625 X 1.5L	2
14	1011748*	ZERK-GREASE: .25 UNF STRAIGHT	1
15	58560	FTG-ELBOW: 8MB-8MJ-90	2
16	1019844	FITTING-RESTRICTOR (8FJ-8MJ .090)	1
17	58890	CYLINDER-HYDRAULIC 3 X 8" 3000	1
18	69078	HOSE: .38 X 132 8FJX-8FJX	1
19	56226	FTG-ADAPTER: 8MB-8MJ	2
20	305587*	WLDMT-AHC MOUNT	1

* INCLUDED IN 305933

INTENTIONALLY LEFT BLANK

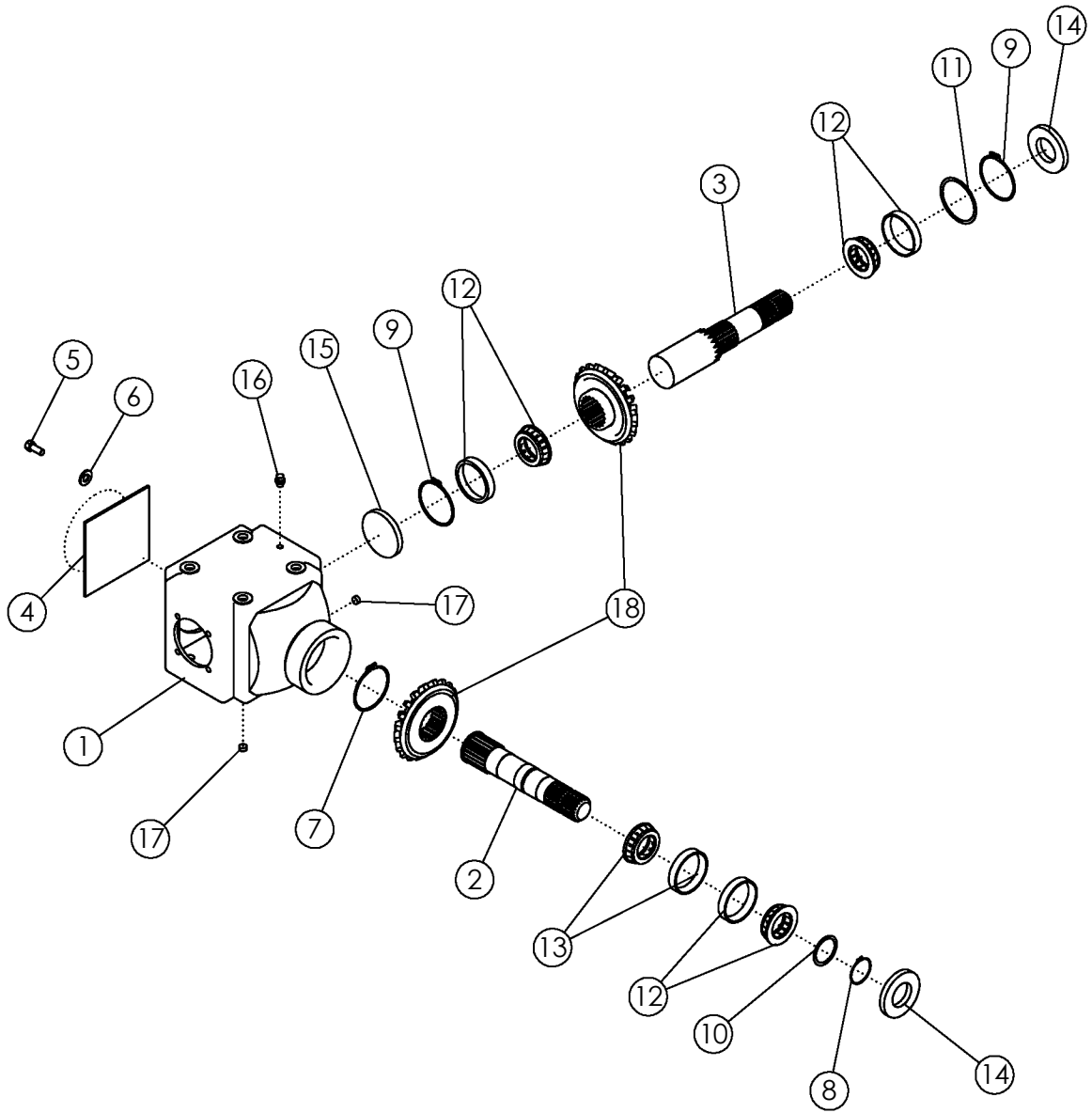

GEARBOX L-TYPE

ITEM	PART NO.	DESCRIPTION	QTY
--	68065	GEARBOX-S2125 1.35:1 L	-
1	68181	HOUSING	1
2	68182	SHAFT	1
3	68183	INPUT SHAFT	1
4	68184	SLEEVE	1
5	68185	SCREW-BOLT HEX M10 X 25 CL8.8	8
6	68186	WASHER	8
7	52521	SNAP RING: EXTERNAL	1
8	54209	SNAP RING	1
9	54210	SNAP RING	2
10	54218	SPACER RING -- .012 PER M THICKNESS	AR
	54219	SPACER RING -- .016 PER M THICKNESS	
	54220	SPACER RING -- .024 PER M THICKNESS	
	54221	SPACER RING -- .032 PER M THICKNESS	
	54222	SPACER RING -- .040 PER M THICKNESS	
	64421	KIT-SPACER RING (INCLUDES SPACERS IN ITEM 10)	
11	54223	SPACER RING -- .012 PER M THICKNESS	AR
	54224	SPACER RING -- .016 PER M THICKNESS	
	54225	SPACER RING -- .024 PER M THICKNESS	
	54226	SPACER RING -- .032 PER M THICKNESS	
	59958	SPACER RING -- 1.00 PER M THICKNESS	
	64422	KIT-SPACER RING (INCLUDES SPACERS IN ITEM 11)	
12	54212	BEARING ROLLER	3
13	68187	BEARING ROLLER	1
14	54214	SEALING RING	2
15	54217	CLOSING CAP	1
16	54204	VENT PLUG	1
17	54215	OIL PLUG	5
18	68188	BEVEL GEAR SET*	1
		*SET INCLUDES GEAR CROWN & GEAR PINNION	

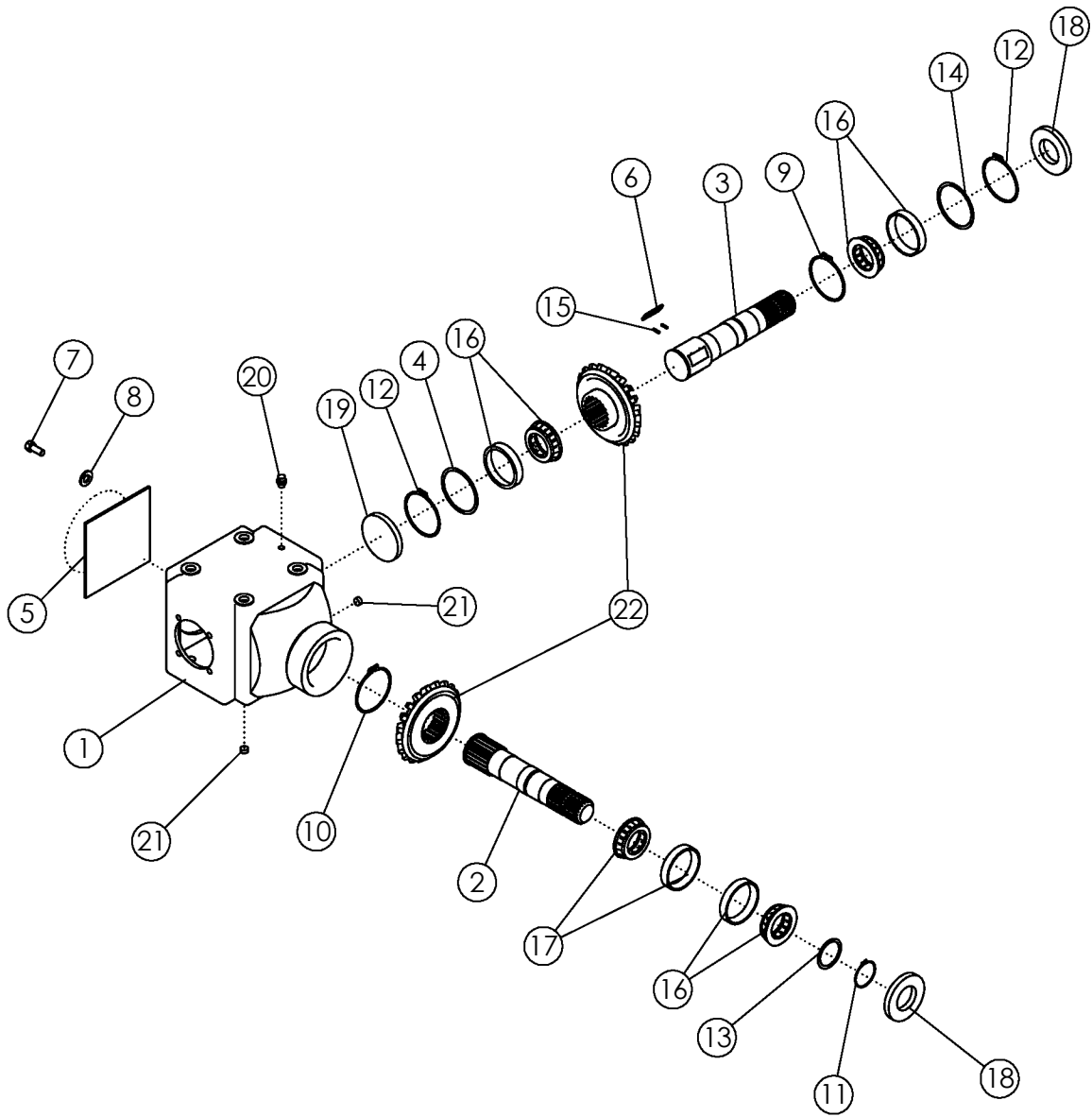

GEARBOX L-TYPE WITH OVERRUN

ITEM	PART NO.	DESCRIPTION	QTY
--	68066	GEARBOX-S2125 1.35:1 L W/OVER RUN CLUTCH	-
1	68181	HOUSING	1
2	68182	SHAFT	1
3	68189	SHAFT-OUTPUT	1
4	68190	SLEEVE	1
5	68184	SLEEVE	1
6	68191	PLUG	6
7	68185	SCREW-BOLT HEX M10 X 25 CL8.8	8
8	68186	WASHER	8
9	68196	SNAP RING-EXTERNAL	1
10	52521	SNAP RING: EXTERNAL	1
11	54209	SNAP RING	1
12	54210	SNAP RING	2
13	54218	SPACER RING -- .012 PER M THICKNESS	AR
	54219	SPACER RING -- .016 PER M THICKNESS	
	54220	SPACER RING -- .024 PER M THICKNESS	
	54221	SPACER RING -- .032 PER M THICKNESS	
	54222	SPACER RING -- .040 PER M THICKNESS	
	64421	KIT-SPACER RING (INCLUDES SPACERS IN ITEM 10)	
14	54223	SPACER RING -- .012 PER M THICKNESS	AR
	54224	SPACER RING -- .016 PER M THICKNESS	
	54225	SPACER RING -- .024 PER M THICKNESS	
	54226	SPACER RING -- .032 PER M THICKNESS	
	59958	SPACER RING -- 1.00 PER M THICKNESS	
	64422	KIT-SPACER RING (INCLUDES SPACERS IN ITEM 11)	
15	59960	SPRING-GEARBOX SHAFT	12
16	54212	BEARING ROLLER	3
17	68187	BEARING ROLLER	1
18	54214	SEALING RING	2
19	54217	CLOSING CAP	1
20	54204	VENT PLUG	1
21	54215	OIL PLUG	5
22	68192	BEVEL GEAR SET*	1
		*SET INCLUDES GEAR CROWN & GEAR PINNION	

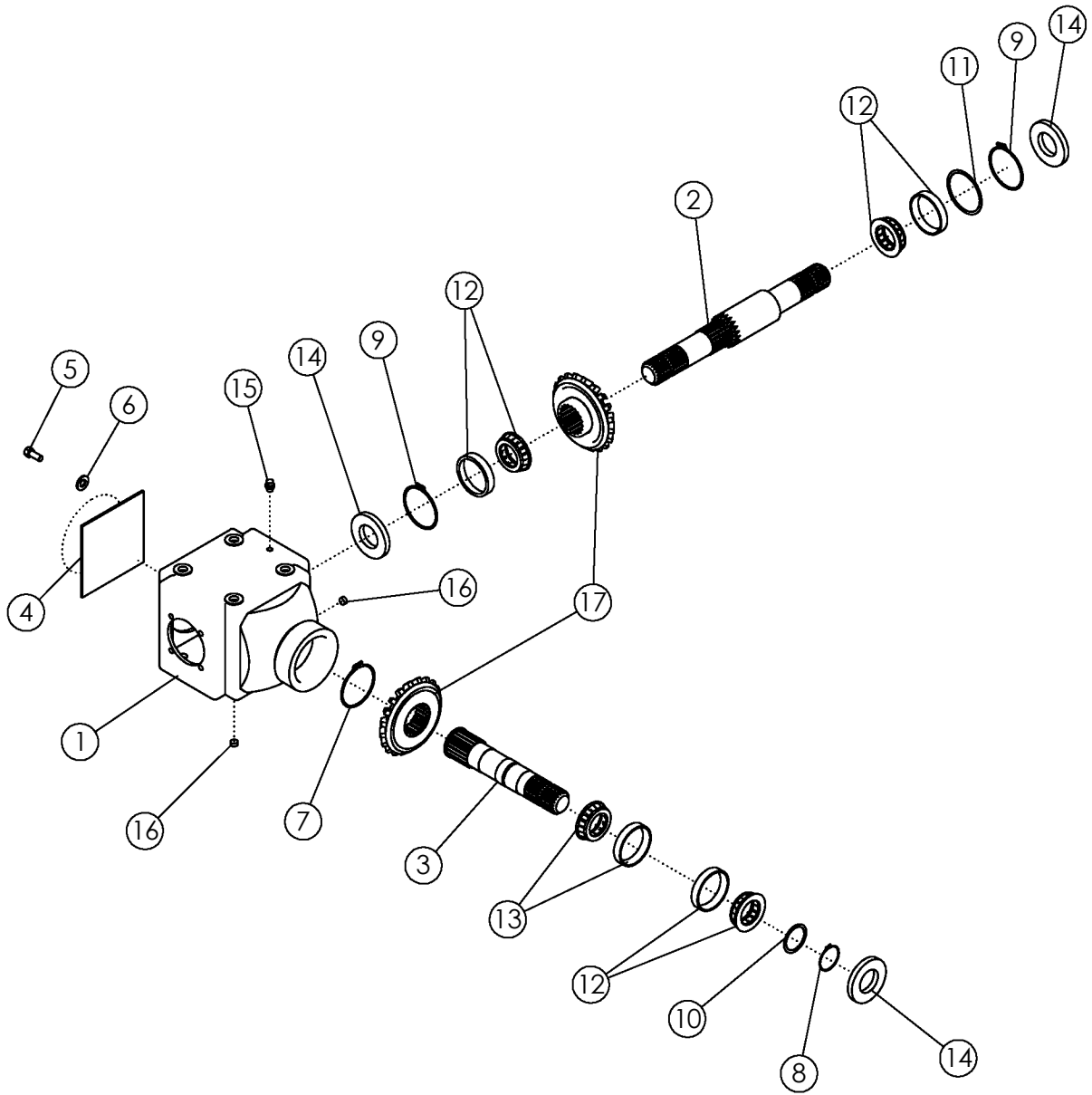

GEARBOX T-TYPE

ITEM	PART NO.	DESCRIPTION	QTY
--	68067	GEARBOX-S2125 1.35:1 T	-
1	68181	HOUSING	1
2	68193	SHAFT-THRU	1
3	68194	SHAFT	1
4	68184	SLEEVE	1
5	68185	SCREW-BOLT HEX M10 X 25 CL8.8	8
6	68186	WASHER	8
7	52521	SNAP RING: EXTERNAL	1
8	54209	SNAP RING	1
9	54210	SNAP RING	2
10	54218	SPACER RING -- .012 PER M THICKNESS	AR
	54219	SPACER RING -- .016 PER M THICKNESS	
	54220	SPACER RING -- .024 PER M THICKNESS	
	54221	SPACER RING -- .032 PER M THICKNESS	
	54222	SPACER RING -- .040 PER M THICKNESS	
	64421	KIT-SPACER RING (INCLUDES SPACERS IN ITEM 10)	
11	54223	SPACER RING -- .012 PER M THICKNESS	AR
	54224	SPACER RING -- .016 PER M THICKNESS	
	54225	SPACER RING -- .024 PER M THICKNESS	
	54226	SPACER RING -- .032 PER M THICKNESS	
	59958	SPACER RING -- 1.00 PER M THICKNESS	
	64422	KIT-SPACER RING (INCLUDES SPACERS IN ITEM 11)	
12	54212	BEARING ROLLER	3
13	68187	BEARING ROLLER	1
14	54214	SEALING RING	2
15	54204	VENT PLUG	1
16	54215	OIL PLUG	5
17	68188	BEVEL GEAR SET*	1
		*SET INCLUDES GEAR CROWN & GEAR PINNION	

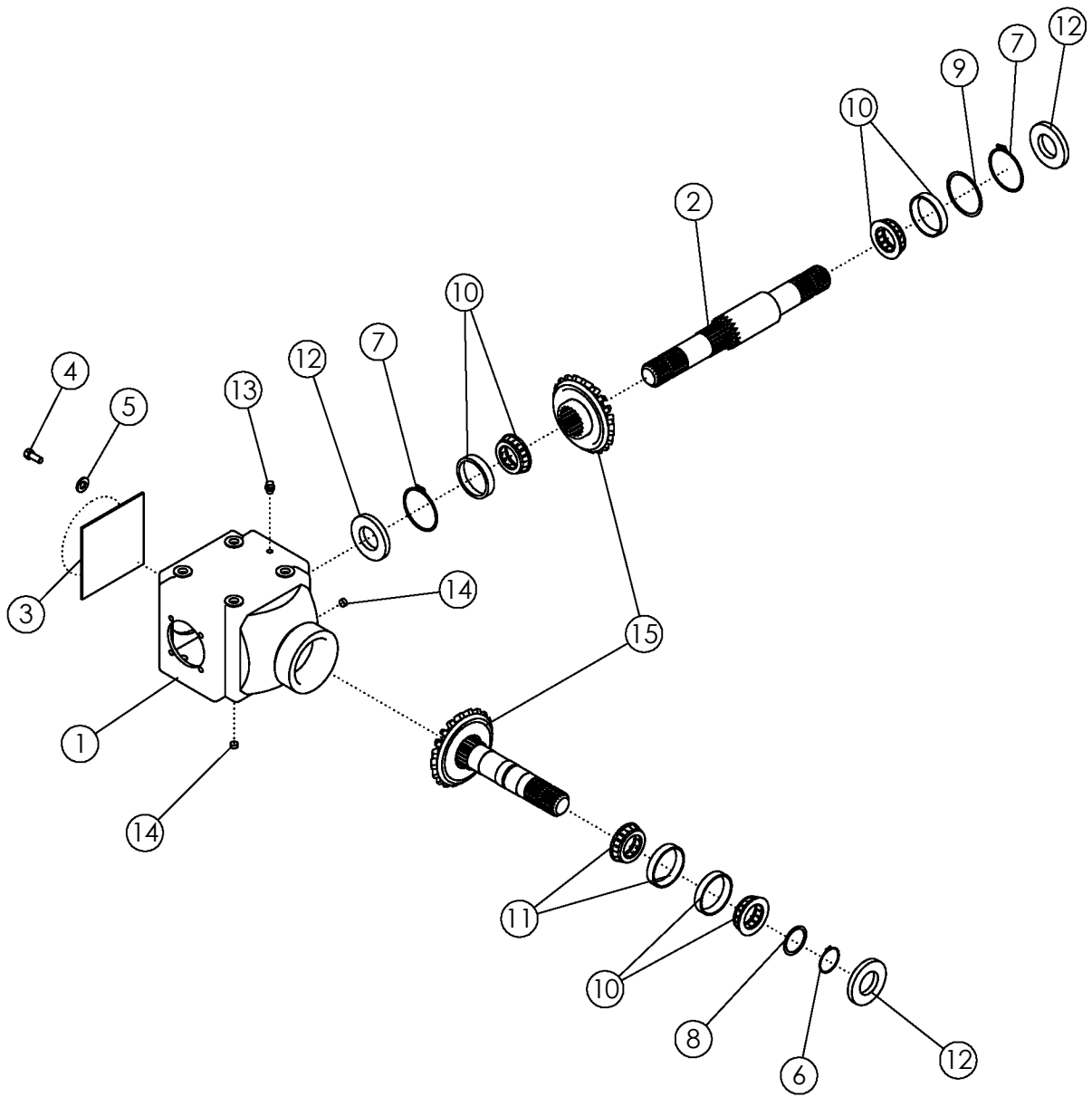

GEARBOX T-TYPE

ITEM	PART NO.	DESCRIPTION	QTY
--	68068	GEARBOX-S2125 1:1.93 T	-
1	68181	HOUSING	1
2	68193	SHAFT-THRU	1
3	68184	SLEEVE	1
4	68185	SCREW-BOLT HEX M10 X25 CL8.8	8
5	68186	WASHER	8
6	54209	SNAP RING	1
7	54210	SNAP RING	2
8	54218	SPACER RING -- .012 PER M THICKNESS	AR
	54219	SPACER RING -- .016 PER M THICKNESS	
	54220	SPACER RING -- .024 PER M THICKNESS	
	54221	SPACER RING -- .032 PER M THICKNESS	
	54222	SPACER RING -- .040 PER M THICKNESS	
	64421	KIT-SPACER RING (INCLUDES SPACERS IN ITEM 10)	
9	54223	SPACER RING -- .012 PER M THICKNESS	AR
	54224	SPACER RING -- .016 PER M THICKNESS	
	54225	SPACER RING -- .024 PER M THICKNESS	
	54226	SPACER RING -- .032 PER M THICKNESS	
	59958	SPACER RING -- 1.00 PER M THICKNESS	
	64422	KIT-SPACER RING (INCLUDES SPACERS IN ITEM 11)	
10	54212	BEARING ROLLER	3
11	68187	BEARING ROLLER	1
12	54214	SEALING RING	2
13	54204	VENT PLUG	1
14	54215	OIL PLUG	5
15	68195	BEVEL GEAR SET*	1
		*SET INCLUDES GEAR CROWN & GEAR PINNION	

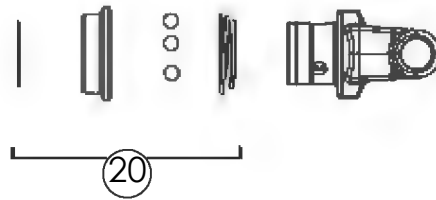
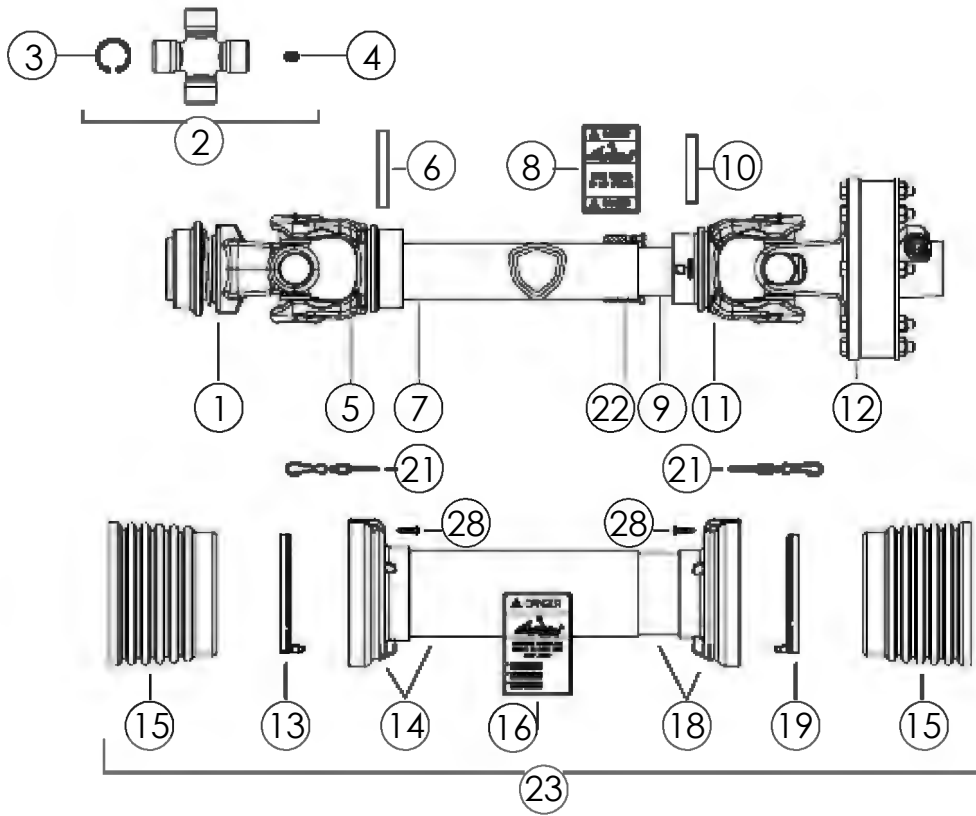

PTO-STANDARD 1.375*-21 #306403 1.75-20 #306404

ITEM	PART NO	DESCRIPTION	QTY
1	54198	YOKE-STD 1.375	1
	69866	YOKE-STD 1.75	
2	305445	CROSS KIT	2
3		CIRCLIP	8
4		GREASE NIPPLE	2
5	306407	YOKE-OUTER TUBE	1
6	306408	FLEXIBLE PIN	1
7	306409	TUBE OUTER	1
8	63293	DECAL-DRIVELINE	1
9	306410	TUBE INNER	1
10	55367	FLEXIBLE PIN	1
11	306411	YOKE INNER TUBE	1
12	305198	CLUTCH-TORQUE LIMITER	1
13	68746	BRG RING-OUTER SHIELD	1
14	306413	SHIELD CONE-OUTER	1
15	306412	OUTER SHIELD	1
16	63294	DECAL-DRIVELINE	1
17	68748	SCREW-SELF TAPPING	6
18	306414	CONE SET-INNER SHIELD	1
19	68752	BRG RING-INNER SHIELD	1
20	69871	KIT-BALL COLLAR 1.375	1
	69872	KIT-BALL COLLAR 1.75	
21	69873	CHAIN-COMPLETE	2
22	306415	COLLAR-GREASE	1
23	306406	KIT-SHIELD COMPLETE W/CHAINS	1

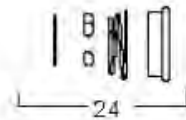
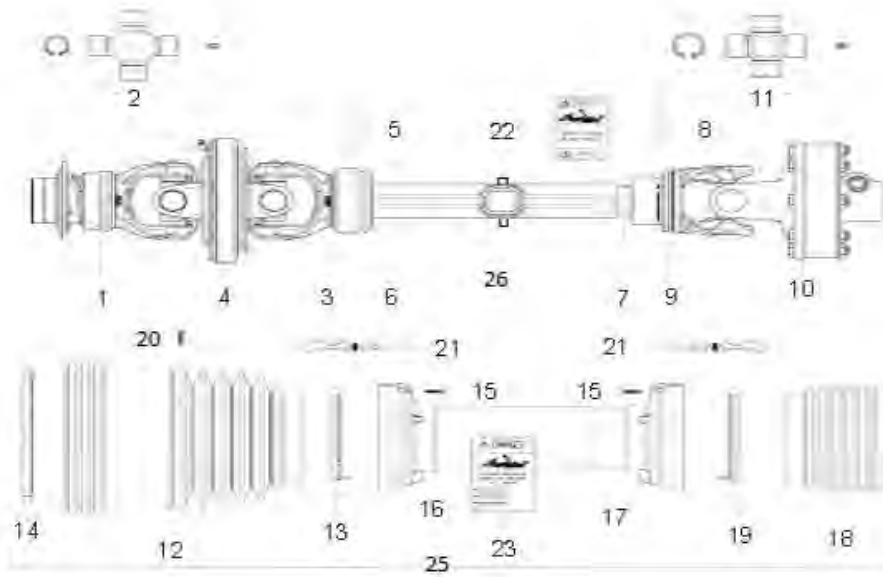

**PTO CV 1-3/8-21 #69681
& 1-3/4-20 #69682**

ITEM	PART NO.	DESCRIPTION	QTY
1	68758	YOKE-CV 1.375	1
	68734	YOKE-CV 1.750	
2	68735	CROSS-KIT	1
3	68736	YOKE-CV OUTER EXT TUBE	1
4	68737	CENTRAL BODY-CV JOINT	1
5	68738	PIN-ROLL	1
6	69684	TUBE-DRIVE OUTER (CV)	1
7	69685	TUBE-DRIVE INNER (CV)	1
8	68741	PIN-ROLL	1
9	68742	YOKE-CV INNER TUBE	1
10	305196	CLUTCH-TORQUE LIMITER (CV)	1
11	68744	CROSS-KIT	1
12	68745	CONE-SHIELD OUTER	1
13	68746	BEARING-SHIELD OUTER	1
14	68747	BEARING-SHIELD CONE	1
15	68748	SCREW-SELF TAPPING	6
16	68749	SHIELD-SAFETY TUBE OUTER	1
17	68750	SHIELD-SAFETY TUBE INNER	1
18	68751	CONE-SHIELD INNER	1
19	68752	BEARING-SHIELD INNER	1
20	69688	SCREW-SELF TAPPING FLANGE HEAD	6
21	69689	CHAIN-COMPLETE	2
22	63293	DECAL-DRIVELINE	1
23	63294	DECAL-DRIVELINE	1
24	69690	KIT-BALL COLLAR 1.375 (CV)	1
	68755	KIT-BALL COLLAR 1.750 (CV)	
25	68760	KIT-SHIELD COMPLETE W/CHAINS	1
26	69687	ZERK-GREASE: M6 X 1 SHORT	2

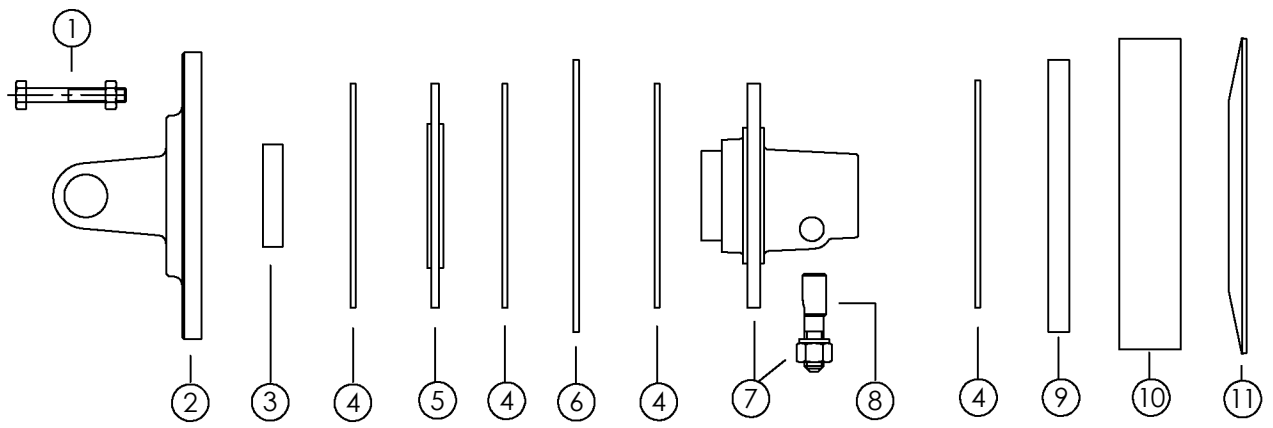

CLUTCH TORQUE LIMITER #305196(CV) & #305198(STD)

ITEM	PART NO.	DESCRIPTION	QTY
1	63300	SCREW	8
2	69693	YOKE-FLANGE (CV)	1
	69864	YOKE-FLANGE (STD)	
3	63295	BUSHING	1
4	69692	LINING	4
5	69858	PLATE-LINING	1
6	69859	PLATE-INNER	1
7	69860	HUB	1
8	68782	KIT-TAPER PIN	1
9	69861	PLATE-THRUST	1
10	69862	SPACER	1
11	305197	SPRING	1

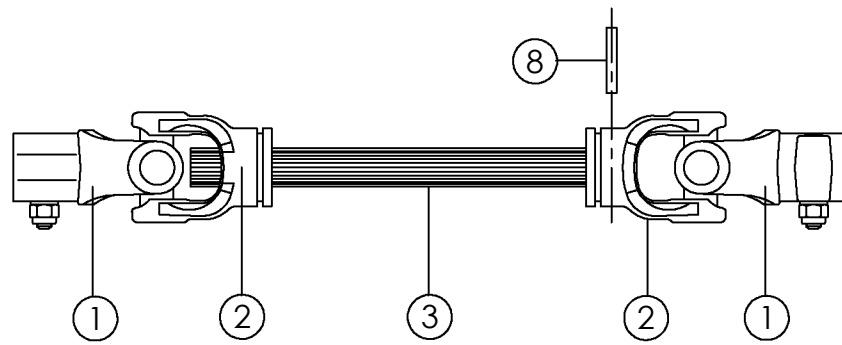
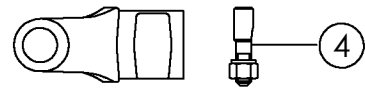
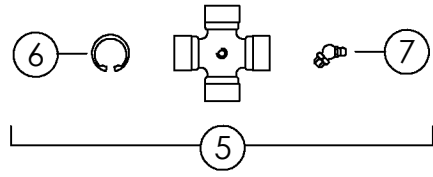

SIDE DRIVELINE #52397

ITEM	PART NO.	DESCRIPTION	QTY
1	68731	TRACTOR YOKE	2
2	54244	YOKE	2
3	63593	SHAFT-SPLINED	1
4	63594	TAPER PIN KIT	2
5	54235	CROSS KIT	2
6	55361	SNAP RING	8
7	63440	GREASE ZERK	2
8	63472	PIN-ROLL	1

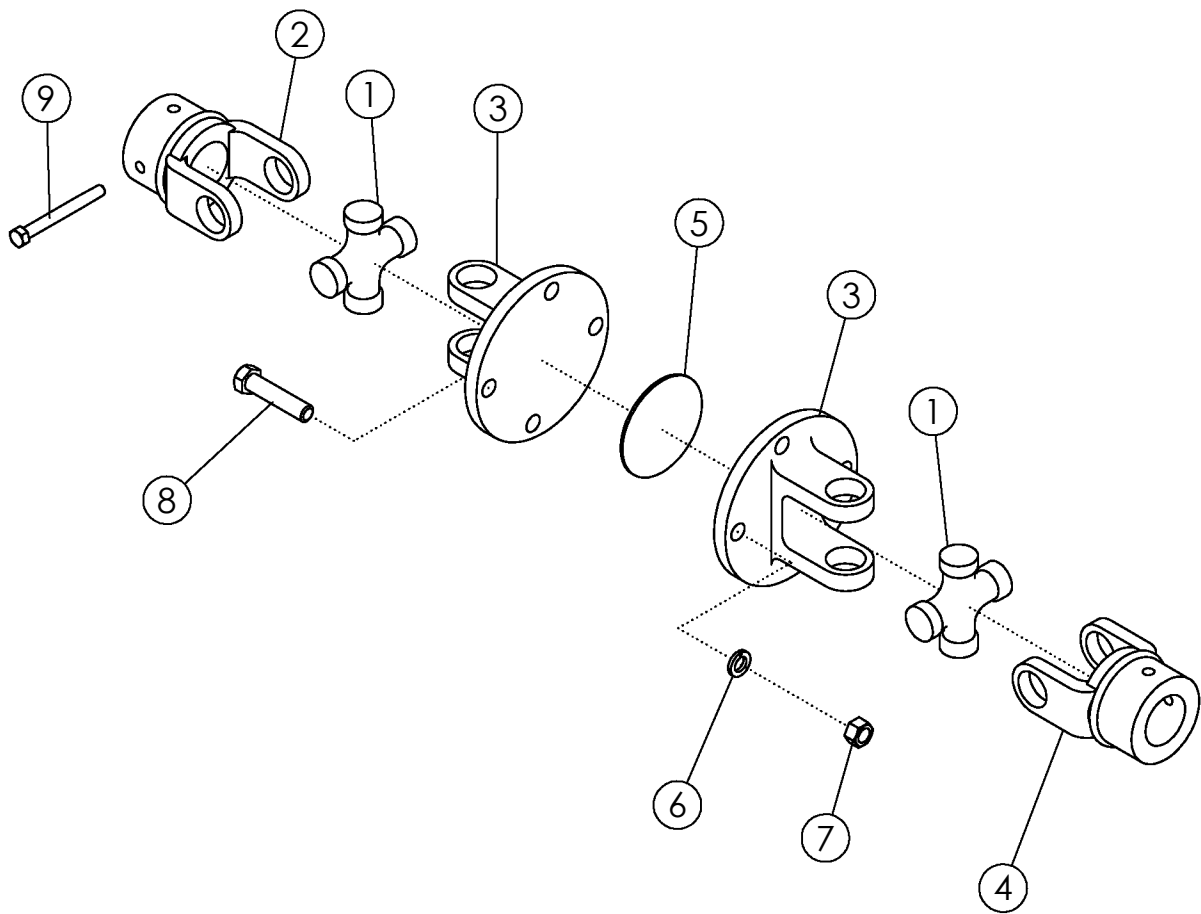

COUPLER-UNIVERSAL JOINT #68443

ITEM	PART NO.	DESCRIPTION	QTY
1	54235	CROSS KIT	2
2	68731	YOKE-COUPLER TAPER PIN 1.750	1
3	68780	FLANGE-YOKE COUPLER	2
4	68732	YOKE COUPLER 1.750	1
5	68781	PLATE-LINER COUPLER	1
6	68591	WASHER-LOCK: M14	4
7	68444	NUT-HEX: M14	4
8	69019	BOLT-HEX: M14 X 2.0 X L50 CL8.8 ZP	4
9	68782	KIT-TAPER PIN 1.750	1

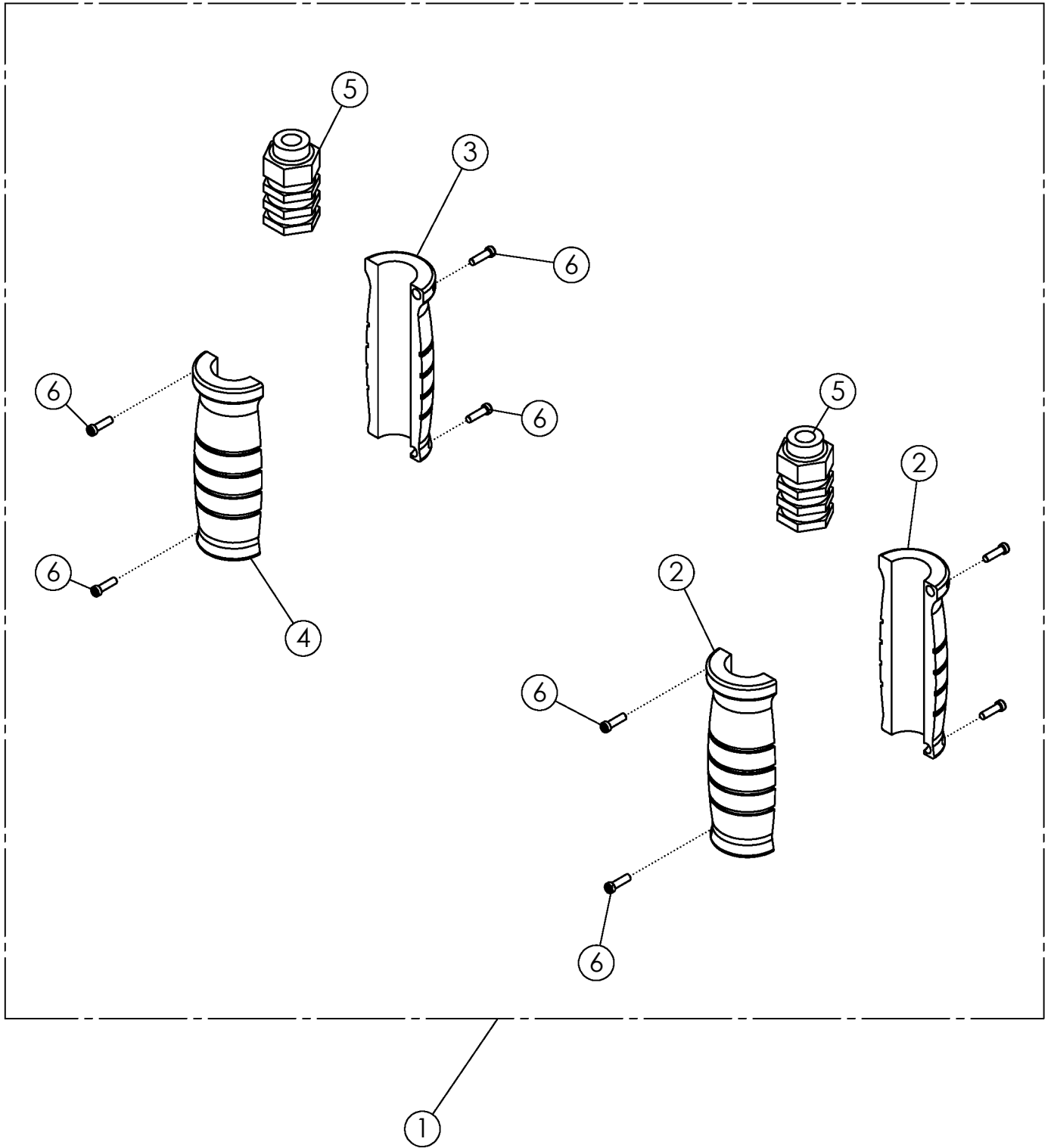

HYDRAULIC LABEL ASSY

ITEM	PART NO.	DESCRIPTION	QTY
1	301920*	HYD LABEL: .50 ORANGE/GRAY SET	1
	301902*	HYD LABEL: .50 BLUE/GRAY SET	
	301917*	HYD LABEL: .50 YELLOW/GRAY SET	
	301914*	HYD LABEL: .50 GREEN/GRAY SET	
	301911*	HYD LABEL: .50 BLACK/GRAY SET	
	301908*	HYD LABEL: .50 RED/GRAY SET	
	302230*	HYD LABEL: .50 RED/GREEN SET	
	302226*	HYD LABEL: .50 BLACK/ORANGE SET	
	302227*	HYD LABEL: .50 BLUE/YELLOW SET	
	301923*	HYD LABEL: .75 GREEN/GRAY SET	
	301928*	HYD LABEL: .75 YELLOW/GRAY SET	
2	301915	HYD LABEL: .50 GREEN HALF EXTEND	2
	301903	HYD LABEL: .50 BLUE HALF EXTEND	
	301909	HYD LABEL: .50 RED HALF EXTEND	
	301918	HYD LABEL: .50 YELLOW HALF EXTEND	
	301921	HYD LABEL: .50 ORANGE HALF EXTEND	
	301912	HYD LABEL: .50 BLACK HALF EXTEND	
	301921	HYD LABEL: .50 ORANGE HALF EXTEND	
	301925	HYD LABEL: .75 GREEN HALF EXTEND	
	301929	HYD LABEL: .75 YELLOW HALF EXTEND	
	302304	HYD LABEL: .75 RED HALF EXTEND	
3	301916	HYD LABEL: .50 GREEN HALF RETRACT	1
	301904	HYD LABEL: .50 BLUE HALF RETRACT	
	301910	HYD LABEL: .50 RED HALF RETRACT	
	301919	HYD LABEL: .50 YELLOW HALF RETRACT	
	301922	HYD LABEL: .50 ORANGE HALF RETRACT	
	301913	HYD LABEL: .50 BLACK HALF RETRACT	
	301922	HYD LABEL: .50 ORANGE HALF RETRACT	
	301926	HYD LABEL: .75 GREEN HALF RETRACT	
	301930	HYD LABEL: .75 YELLOW HALF RETRACT	
	302305	HYD LABEL: .75 RED HALF RETRACT	
4	301905	HYD LABEL: .50 GRAY HALF RETRACT	1
	301927	HYD LABEL: .75 GRAY HALF RETRACT	
5	301906	HYD LABEL: .50 CORE M & F O-RING	2
	301924	HYD LABEL: .75 CORE M & F O-RING	
6	301907	HYD LABEL: SET SCREW	8

* COMES WITH ITEMS 2 THRU 6

69055 SNAP RING PLIERS

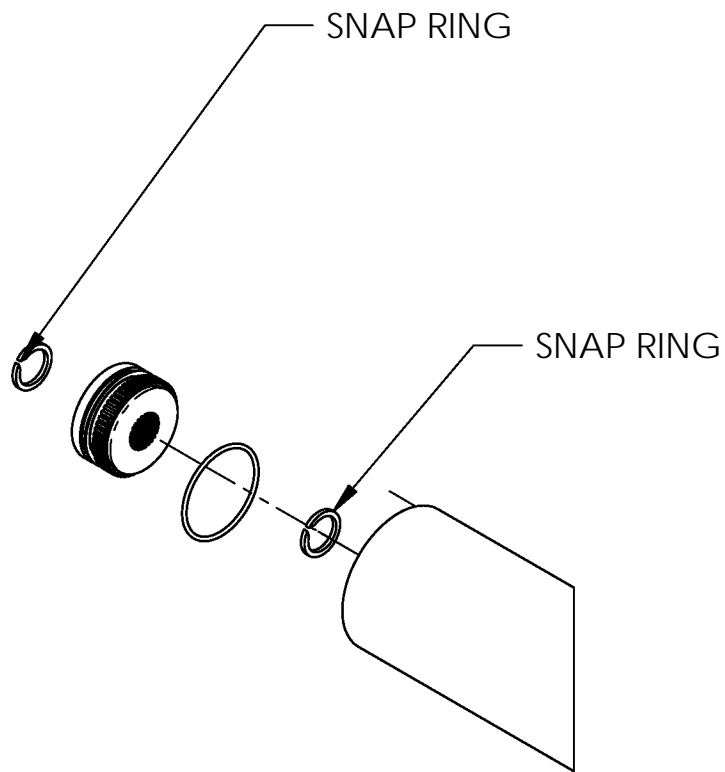
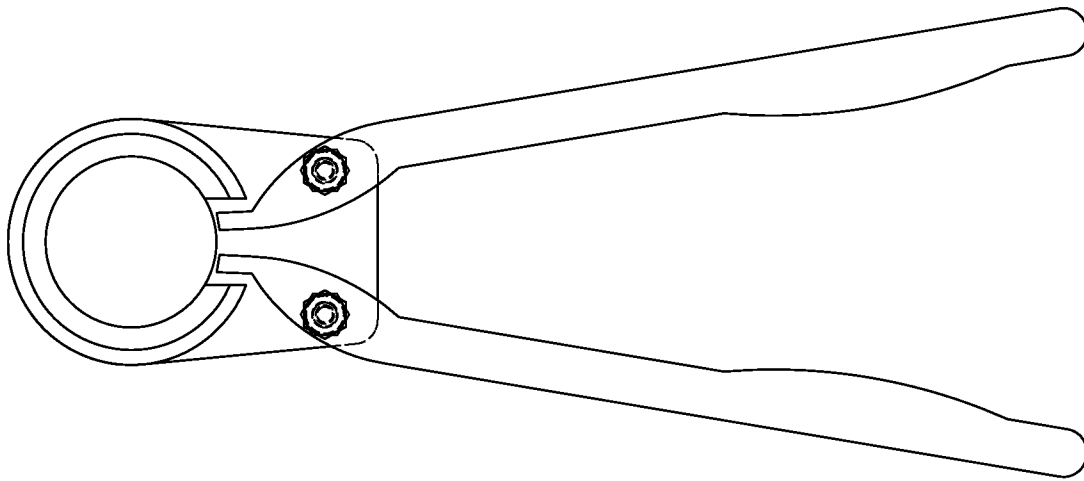

SHAFT REMOVED FOR CLARITY